

This catalog covers:

'08~'09 KVF750 D8F/D9F

GRID NO.

A-1

This grid covers:

Title



PARTS CATALOG

'08~'09 KVF750 D8F/D9F

(KVF750 4x4)

Publications	A-2
Model Identification	A-4
Engine	B-1
Chassis	E-1

© Kawasaki Heavy Industries, Ltd. 2008

Engine No. Location:
RH hand lower part of the crankcase

Year & Model

'08 KVF750D8F

'09 KVF750D9F

Color

- 1. Colored Plastic Super Black (839)
- 2. Colored Plastic Woodsman Green (286)
- 3. Lime Green (777)

- 1. Colored Plastic Super Black (839)
- 2. Colored Plastic Woodsman Green (286)
- 3. Lime Green (777)

VIN No. Range

JKAVFDD1√8B500001 ~ 510500 (Australia only)
JKAVF750DDB600001 ~ 601700 (Europe only)

JKAVFDD1√9B510501 ~ (Australia only)
JKAVF750DDB601701 ~ (Europe only)

Engine No. Range

VF750DE500001 ~

VF750DE500001 ~

This catalog covers:

'08~'09 KVF750 D8F/D9F

GRID NO.

A-2

This grid covers:

Publications

Year & Model	Owner's Manual	A&P Manual		Service Manual		Microfiche
		General	Supplement	Basic	Supplement	
2008 KVF750D8F	99986-1408(Australia only) 99977-1280	99931-1489-01		99924-1394-01		99912-1507-02
2009 KVF750D9F	99986-1464(Australia only) 99977-1332	See above		99924-1394-02		See above

This catalog covers:

'08~'09 KVF750 D8F/D9F

GRID NO.

A-4

This grid covers:

Model I.D. '08~'09 KVF750 D8F/D9F

KVF750D8F

Left Side View

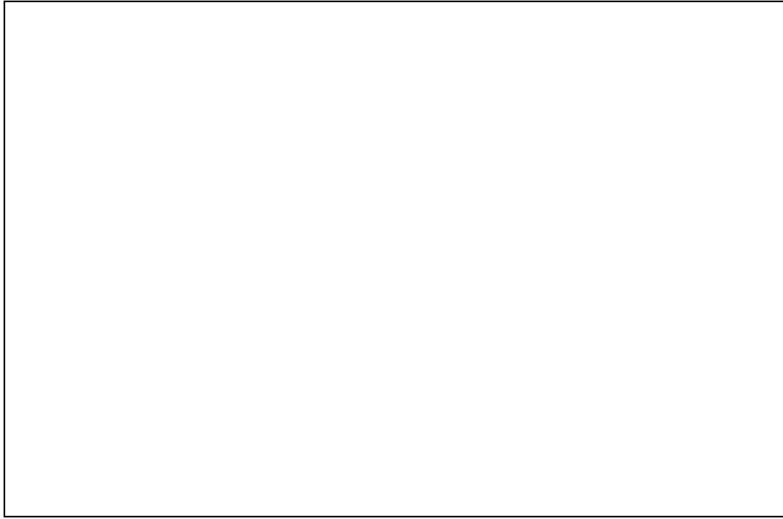

Right Side View



KVF750D9F

Left Side View

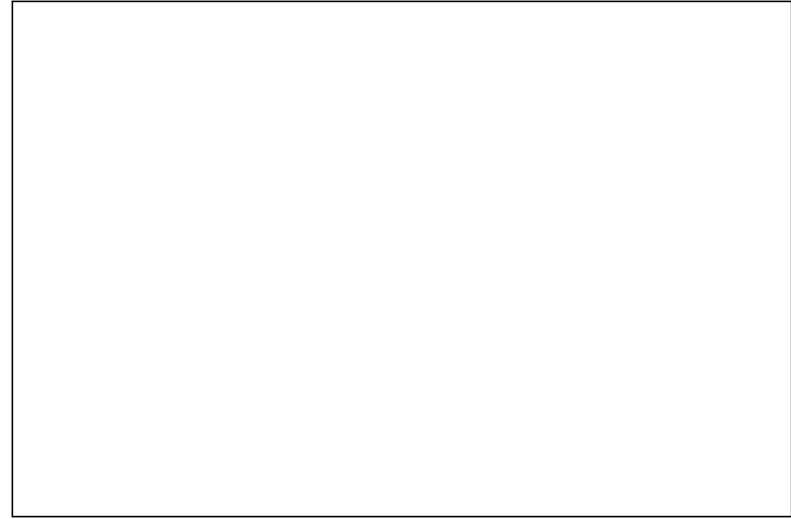

Right Side View



This catalog covers:

'08~'09 KVF750 D8F/D9F Engine

GRID NO.

B-1

This grid covers:

Pictorial Index

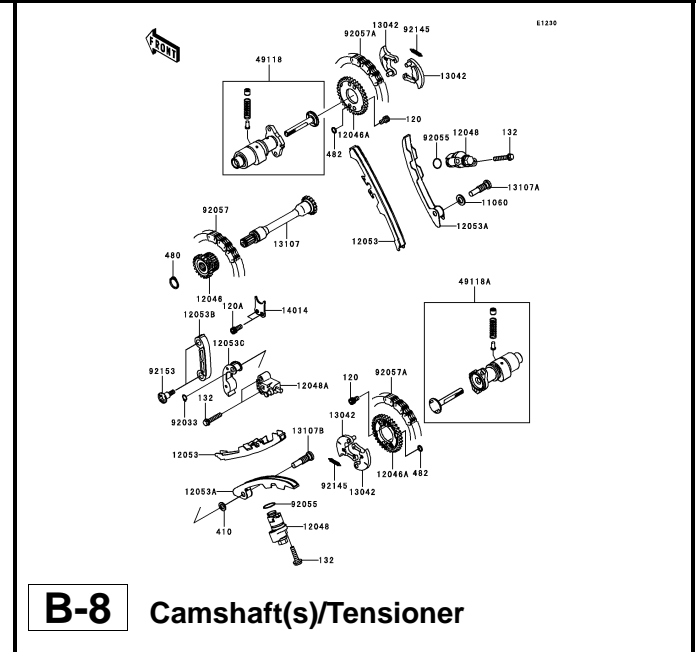
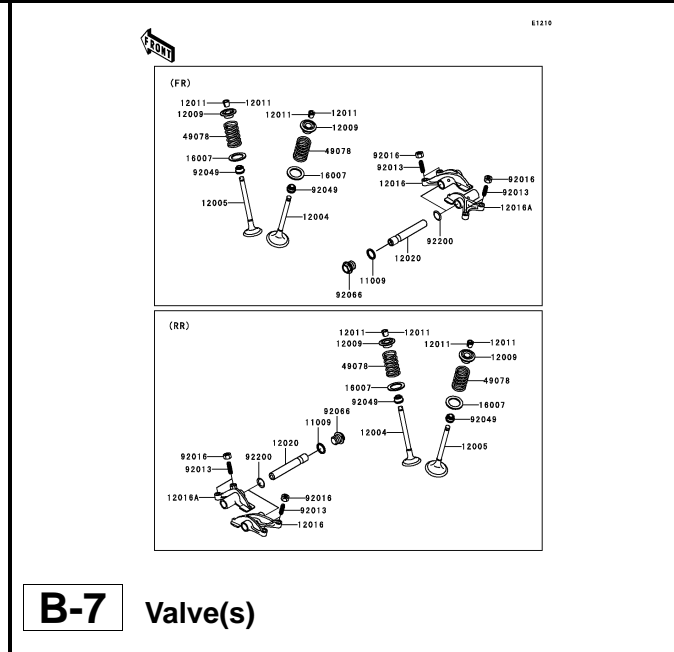
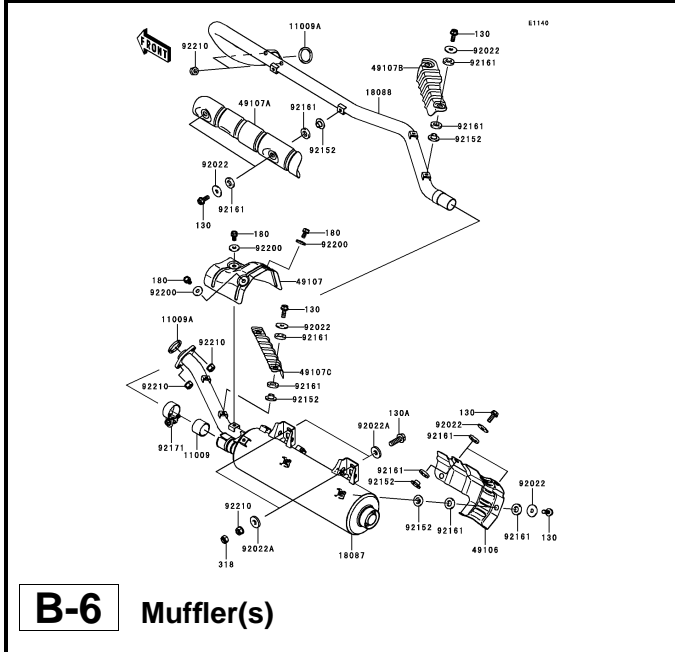
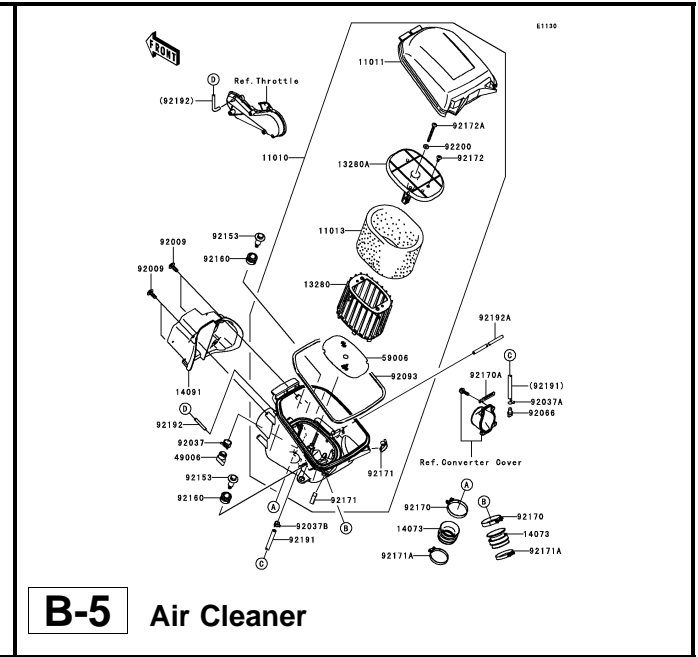
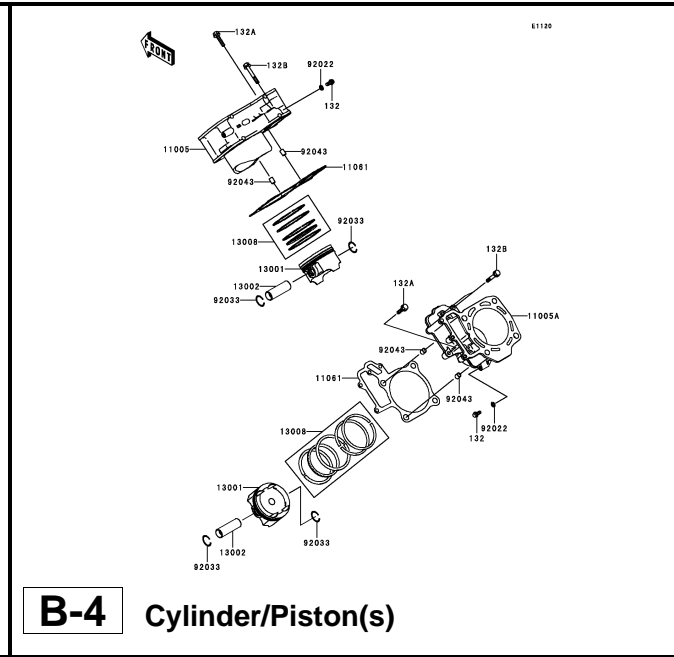
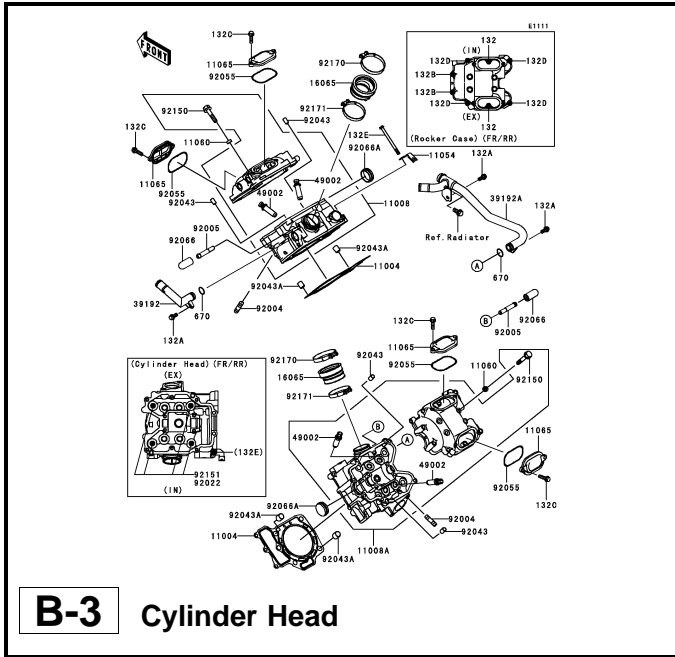

This catalog covers:

'08~'09 KVF750 D8F/D9F Engine

GRID NO.

B-2

This grid covers:

Pictorial Index

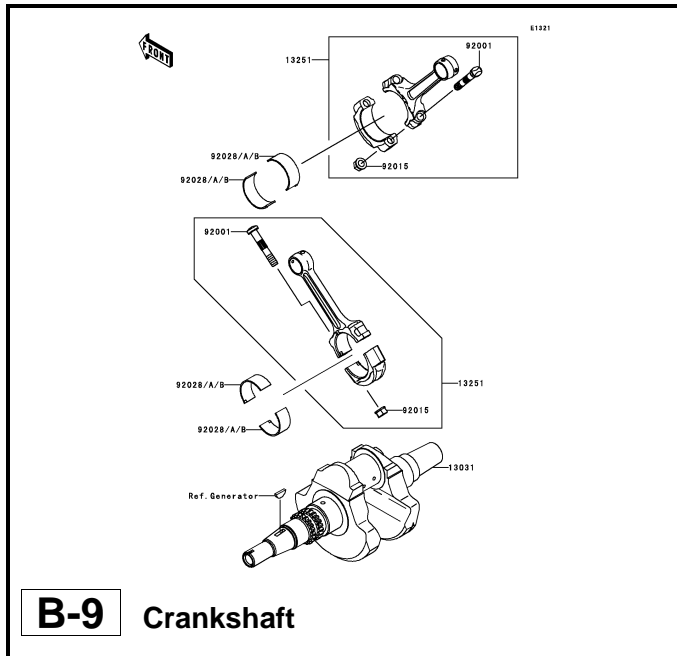

B-9 Crankshaft

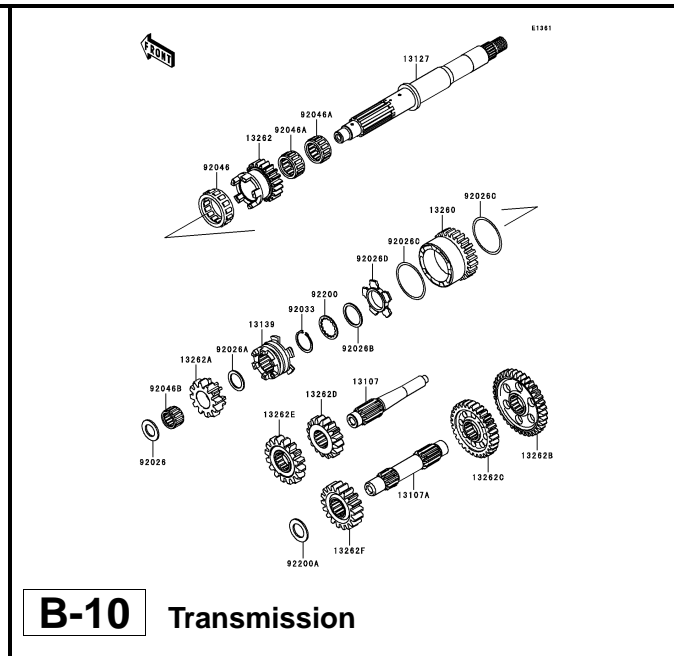

B-10 Transmission

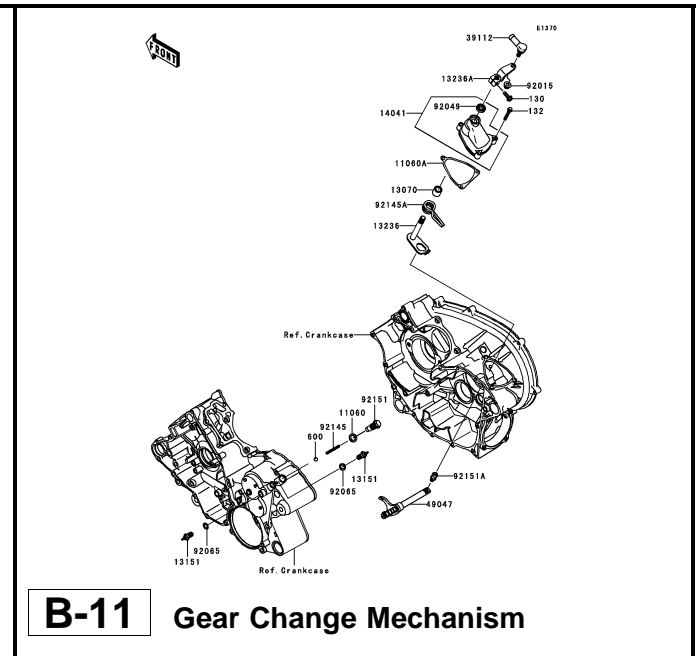

B-11 Gear Change Mechanism

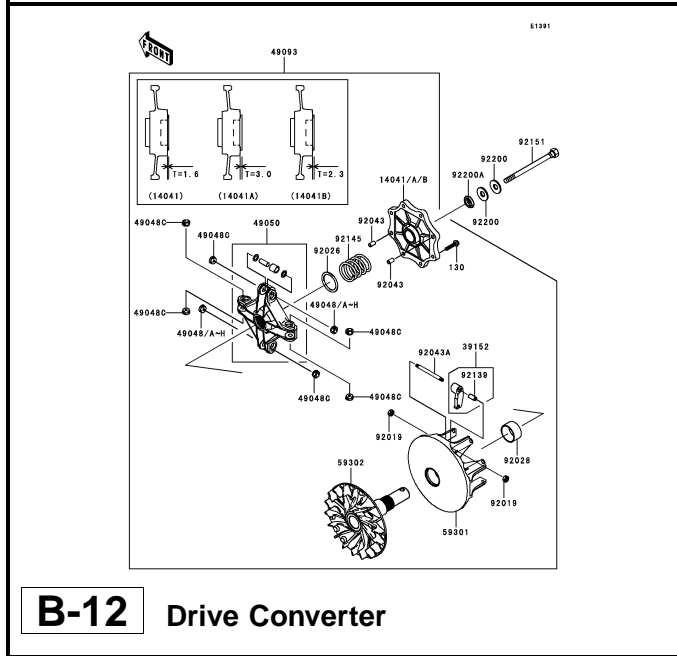

B-12 Drive Converter

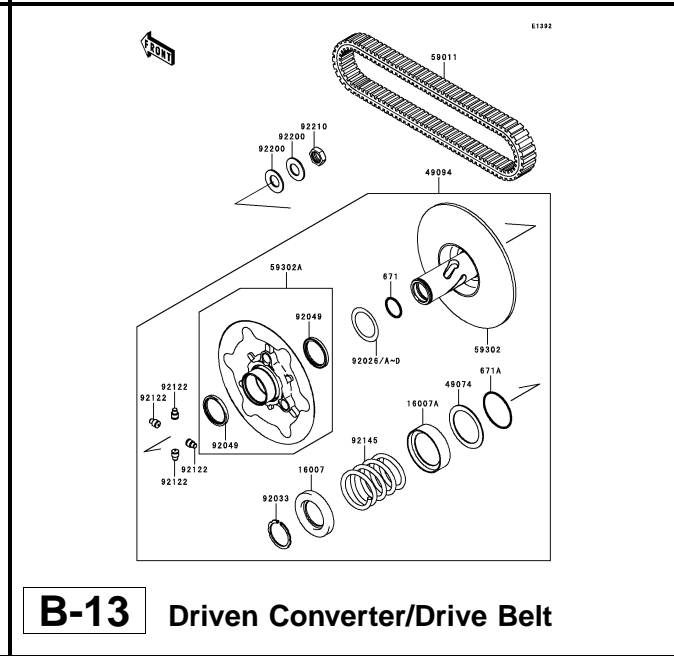

B-13 Driven Converter/Drive Belt

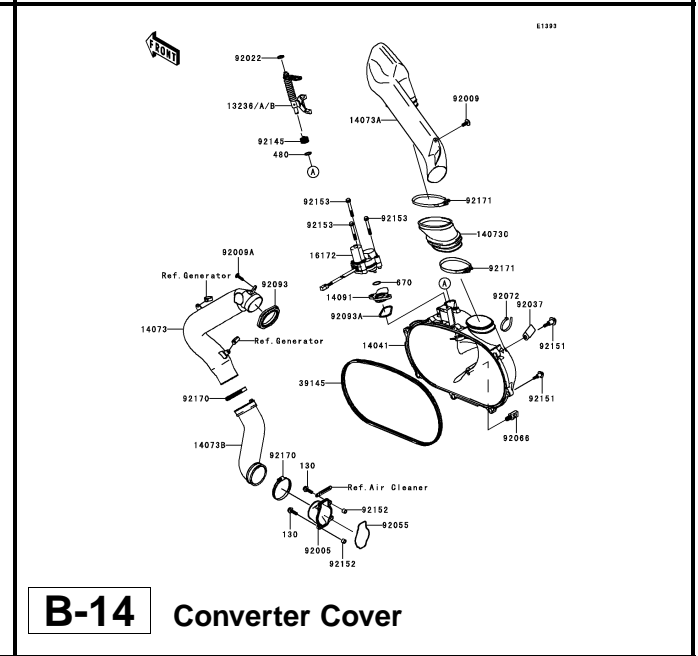

B-14 Converter Cover

This catalog covers:

'08~'09 KVF750 D8F/D9F Engine

GRID NO.

C-2

This grid covers:

Pictorial Index

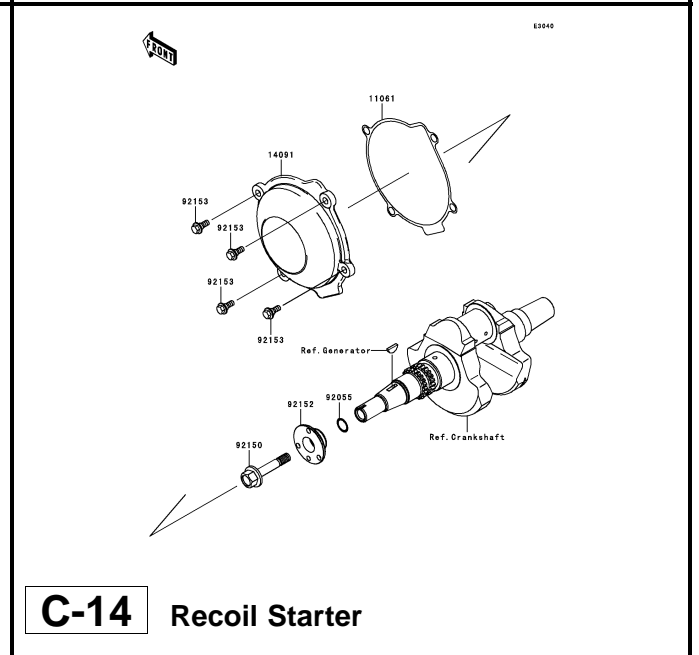
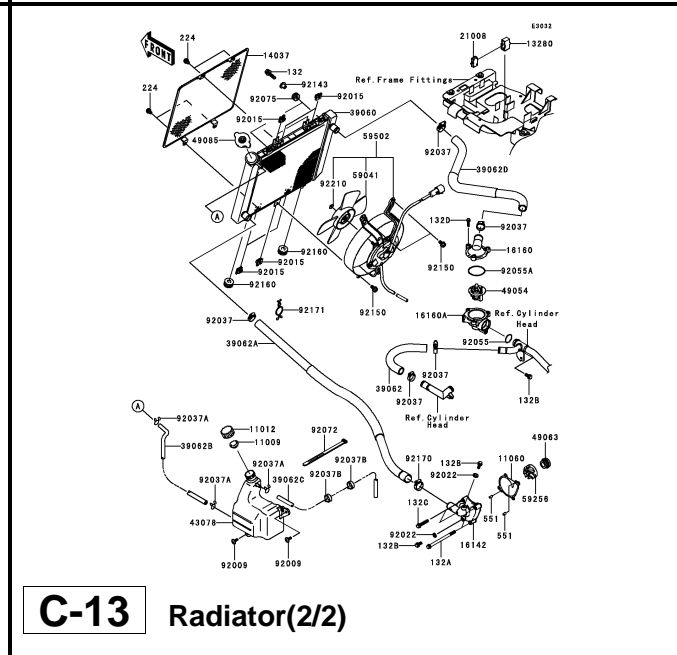
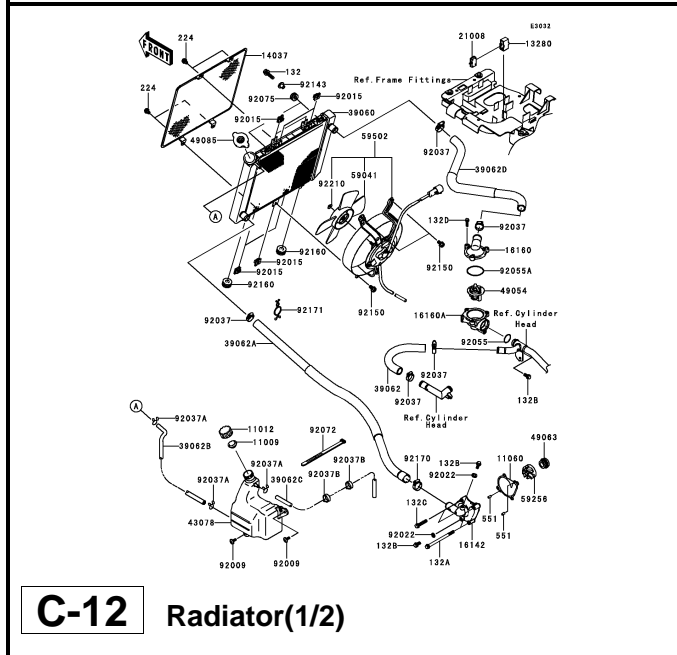
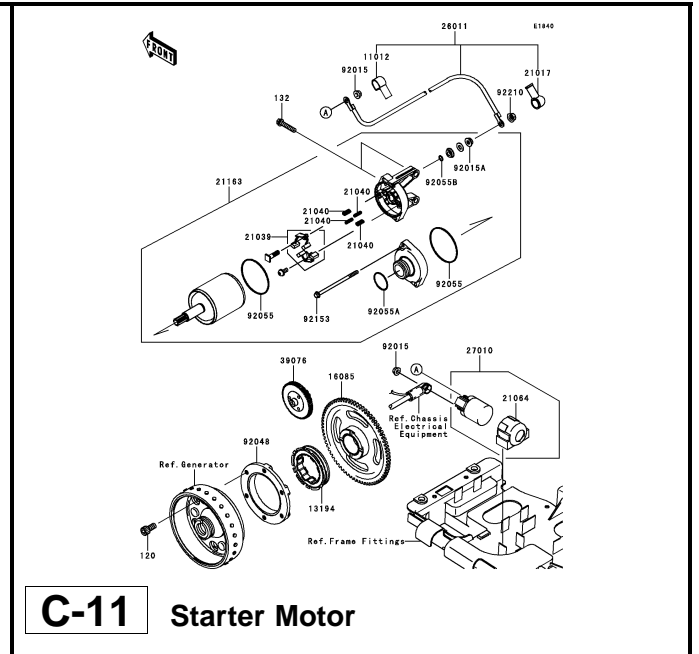
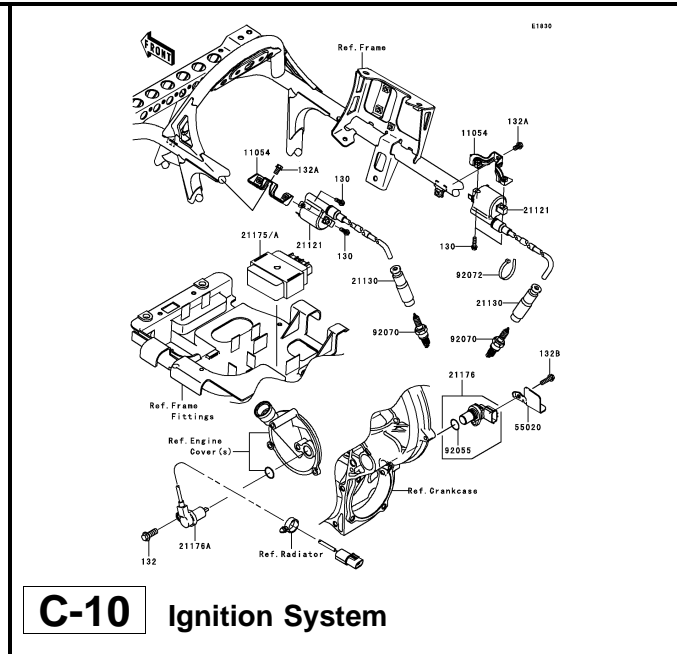
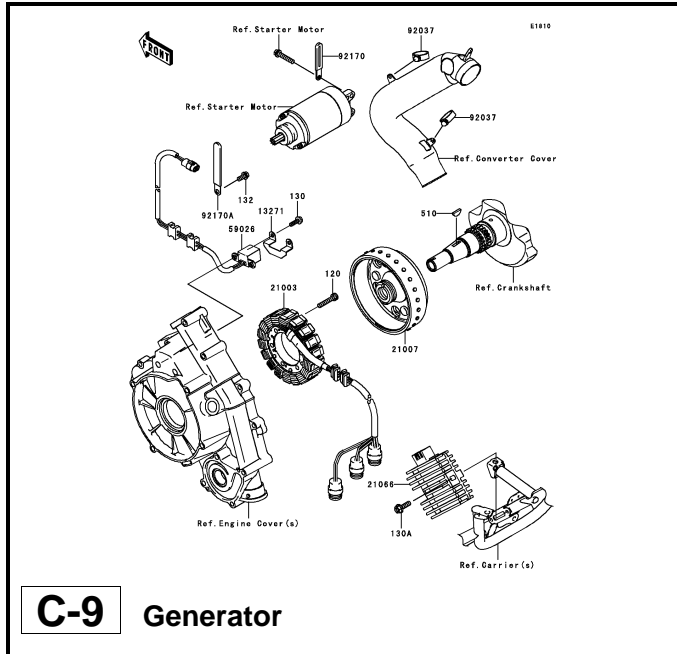

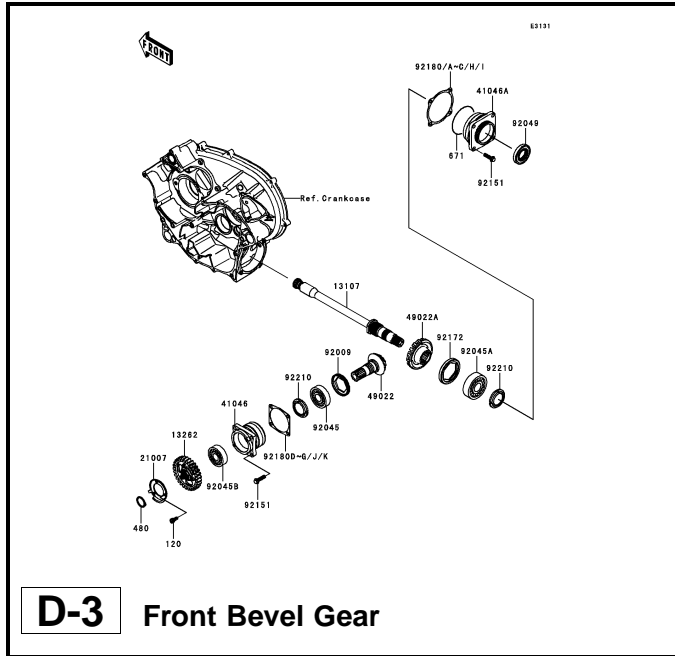

D-3 Front Bevel Gear

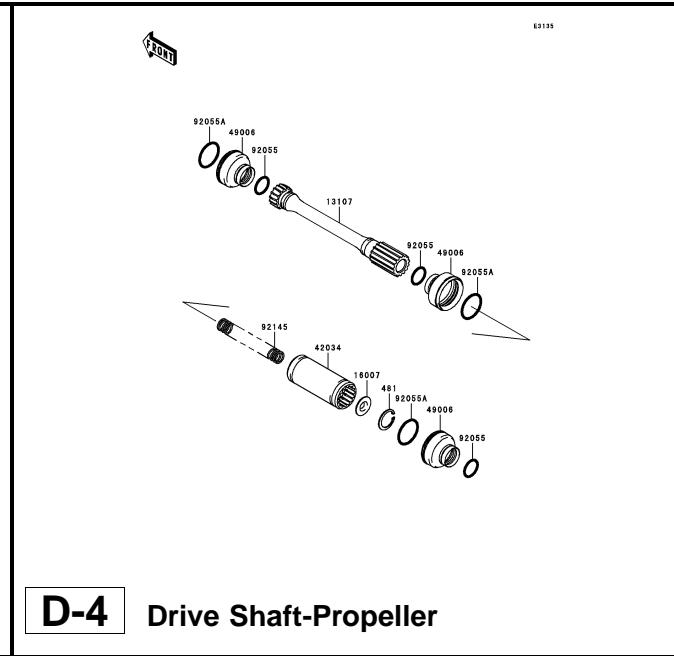

D-4 Drive Shaft-Propeller

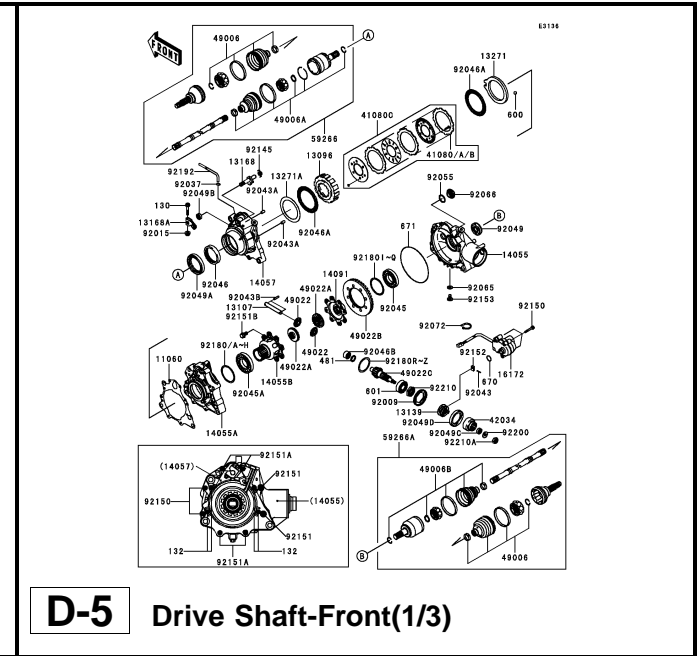

D-5 Drive Shaft-Front(1/3)

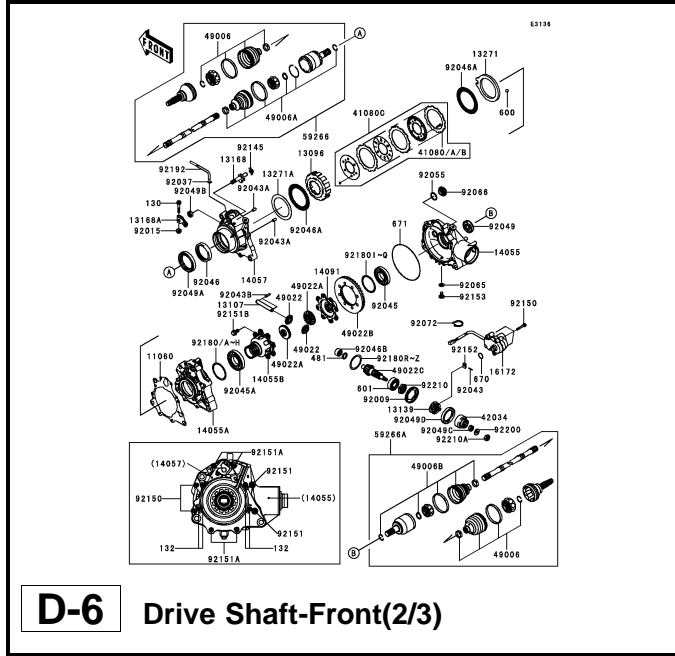

D-6 Drive Shaft-Front(2/3)

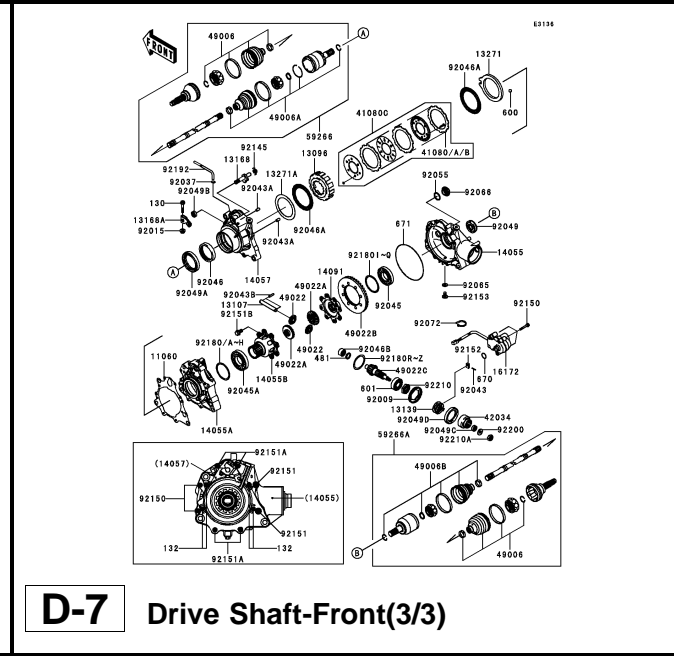

D-7 Drive Shaft-Front(3/3)

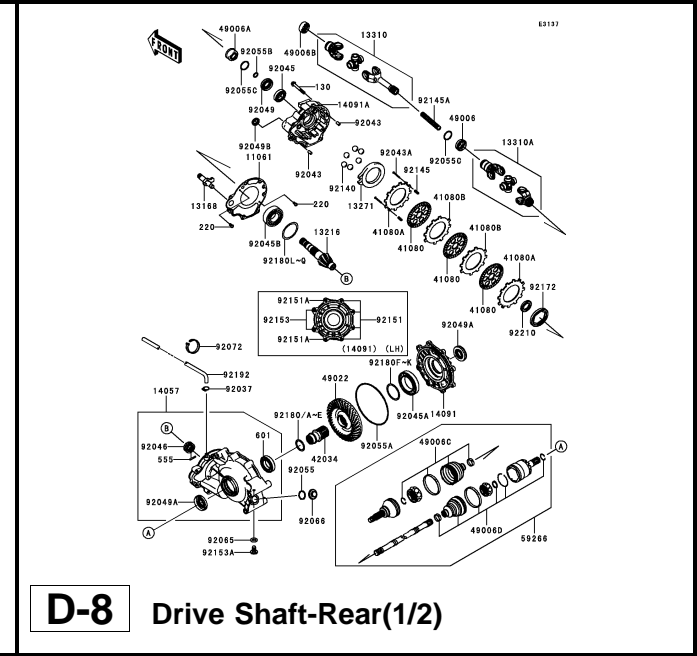

D-8 Drive Shaft-Rear(1/2)

This catalog covers:

'08~'09 KVF750 D8F/D9F Engine

GRID NO.

D-2

This grid covers:

Pictorial Index

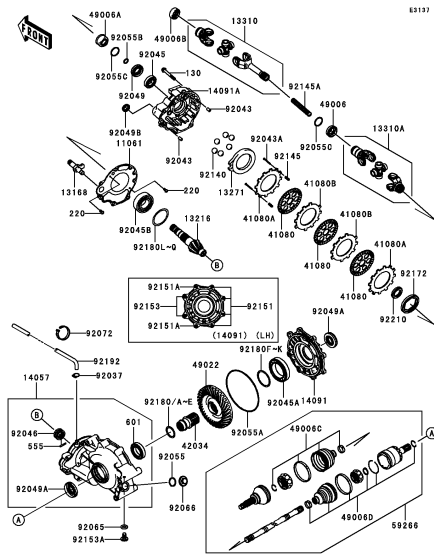

D-9 Drive Shaft-Rear(2/2)

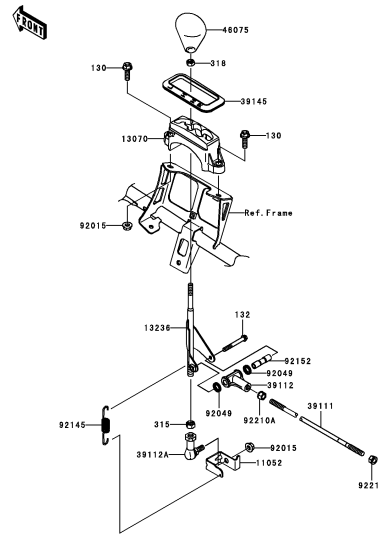

D-10 Control

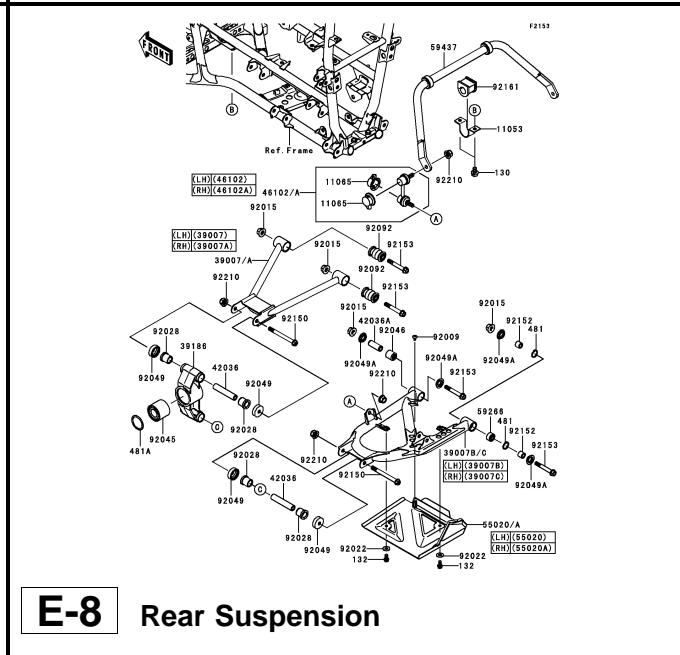
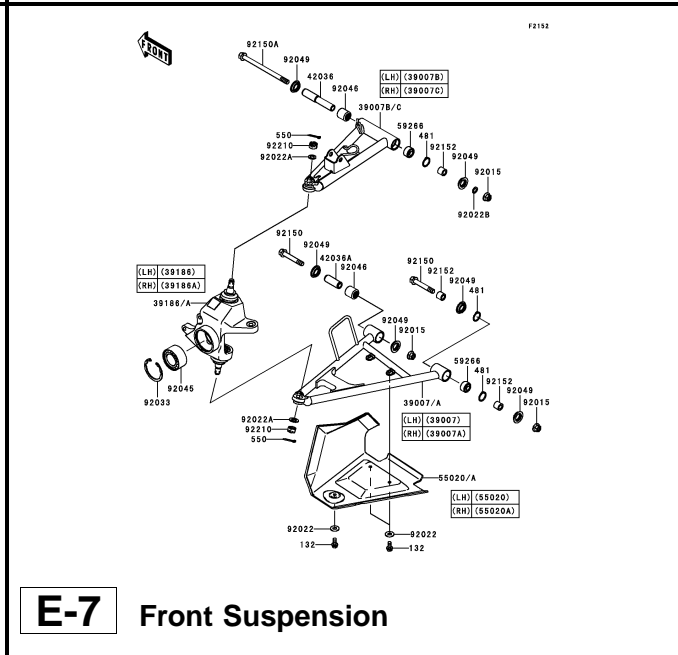
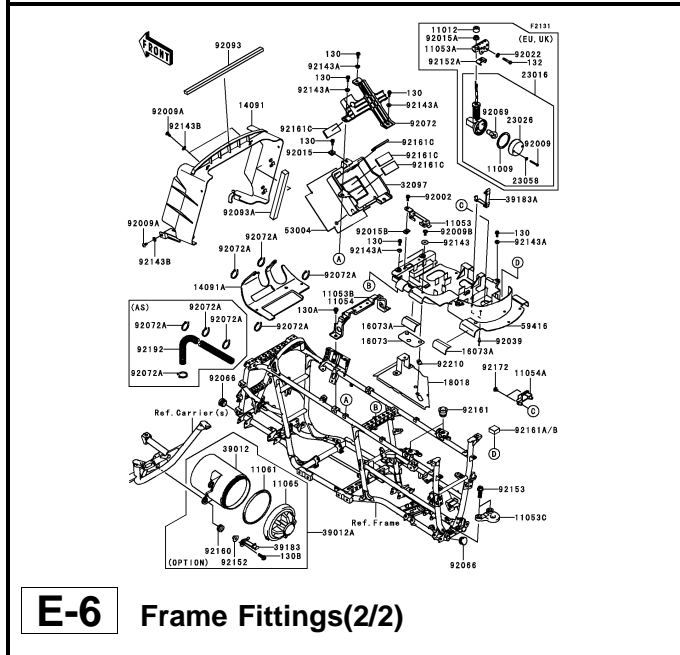
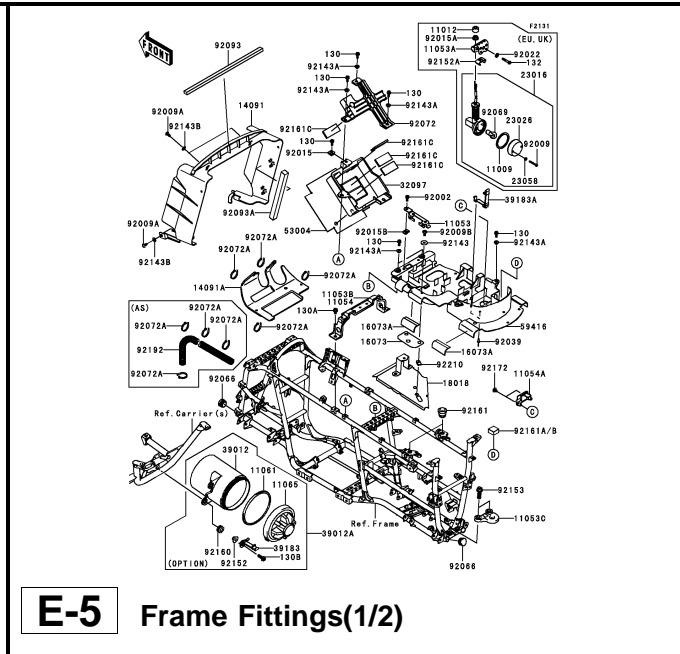
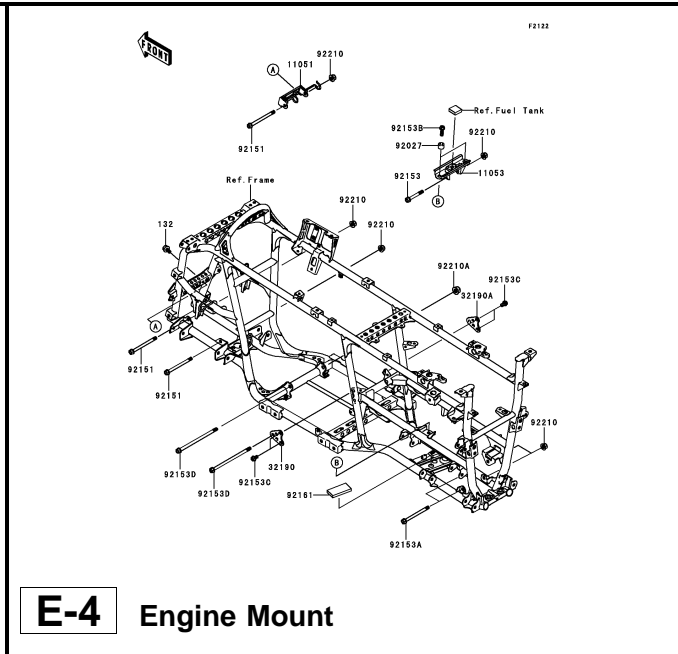
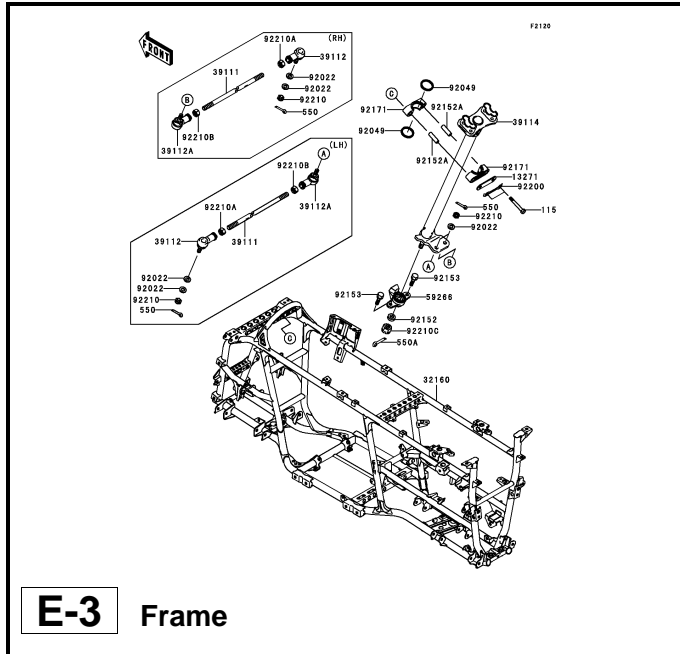

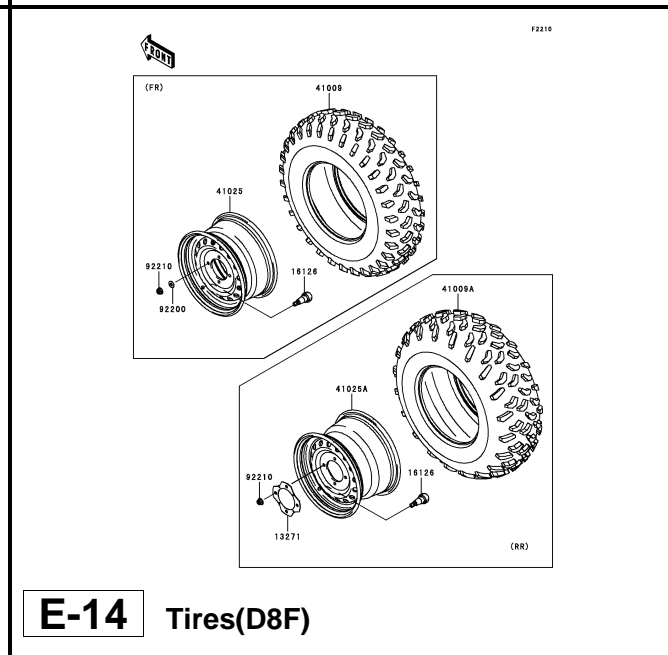
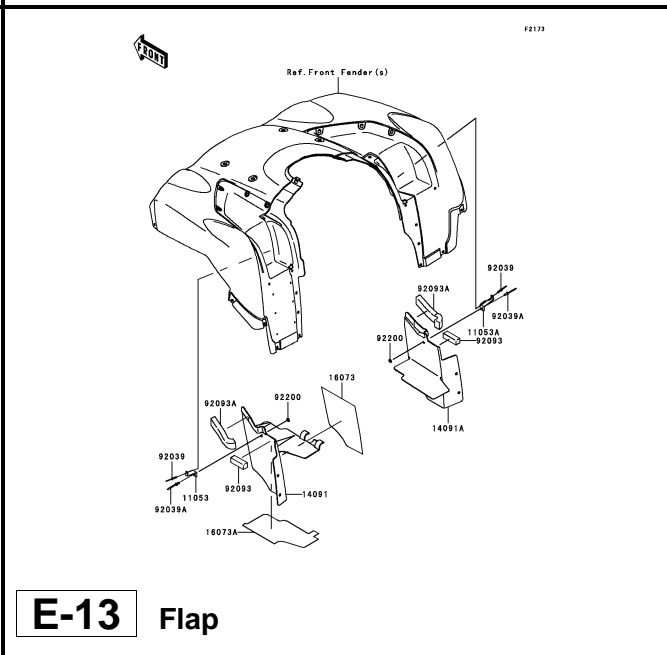
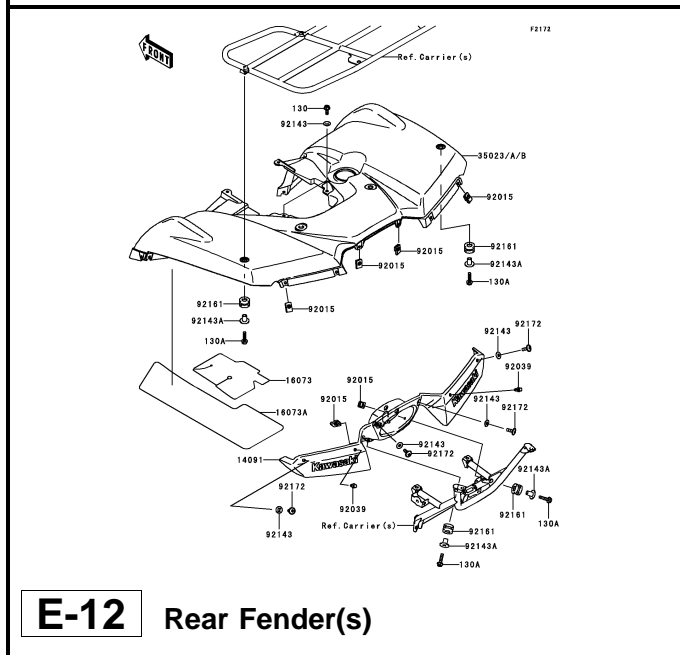
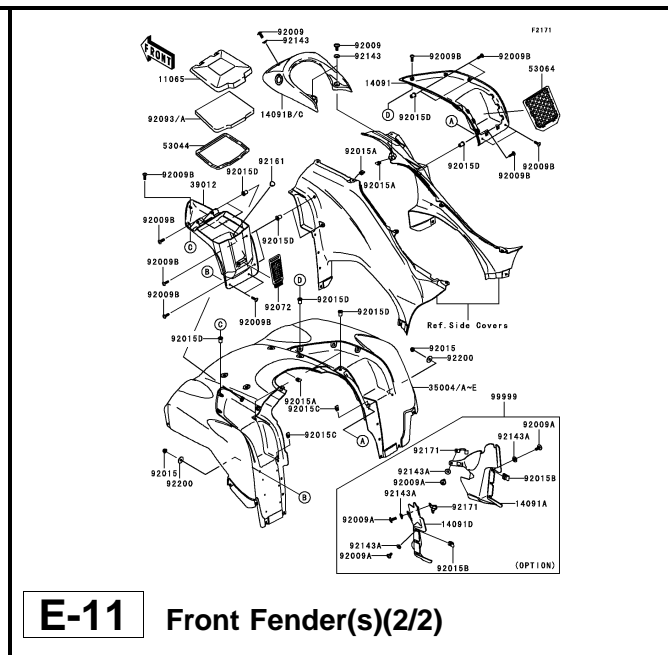
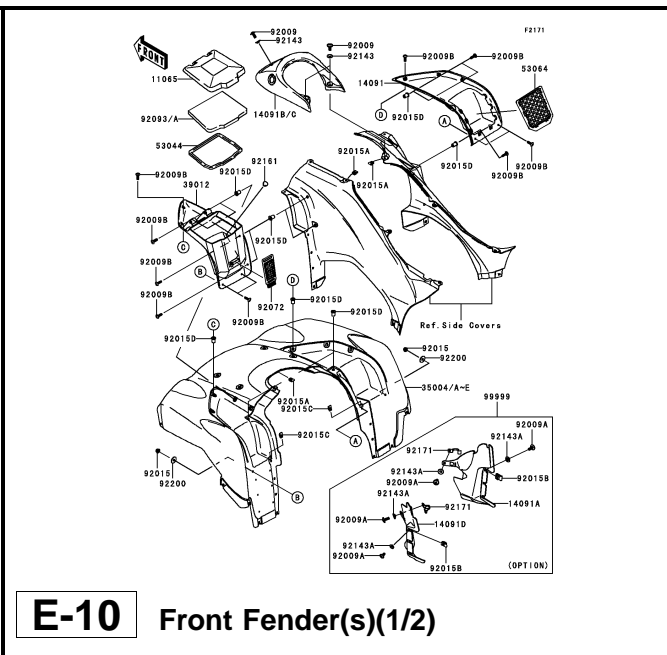
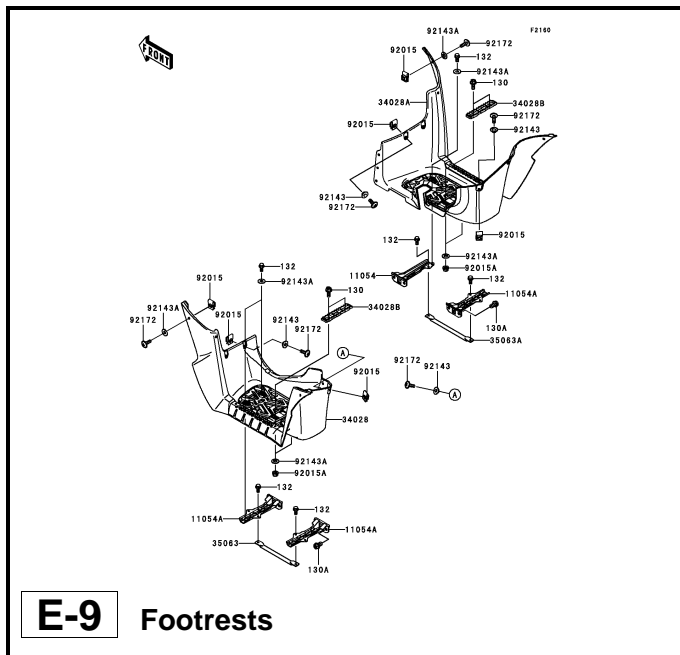

This catalog covers:

'08~'09 KVF750 D8F/D9F Chassis

GRID NO.

F-1

This grid covers:

Pictorial Index

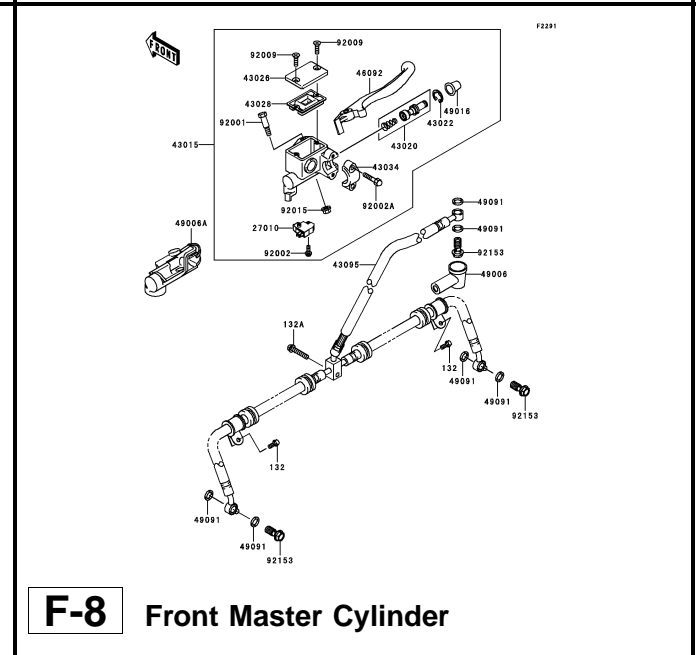
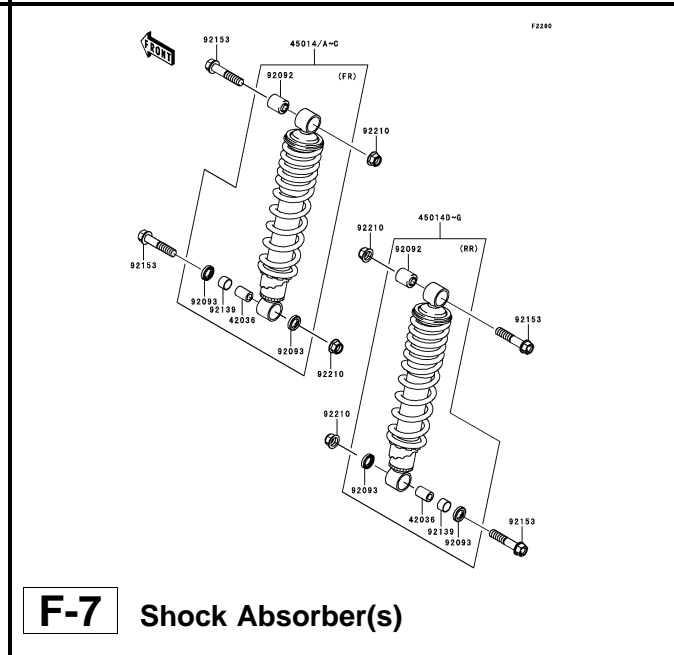
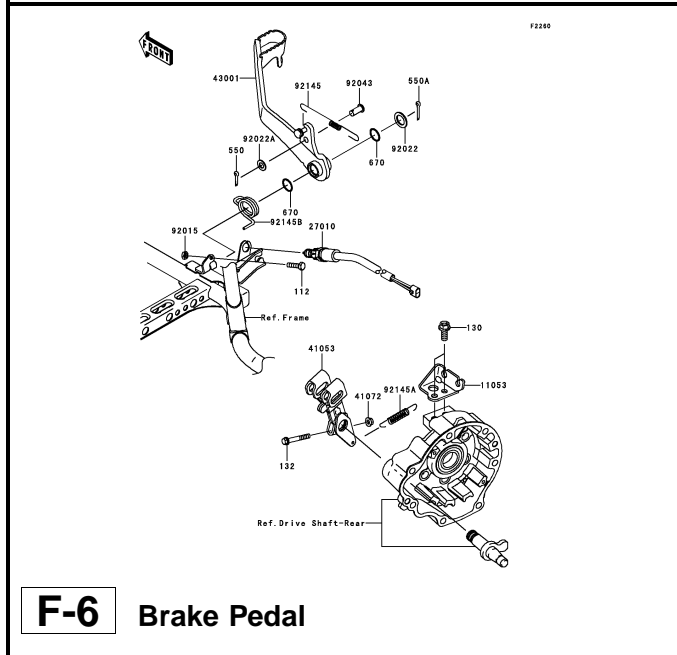
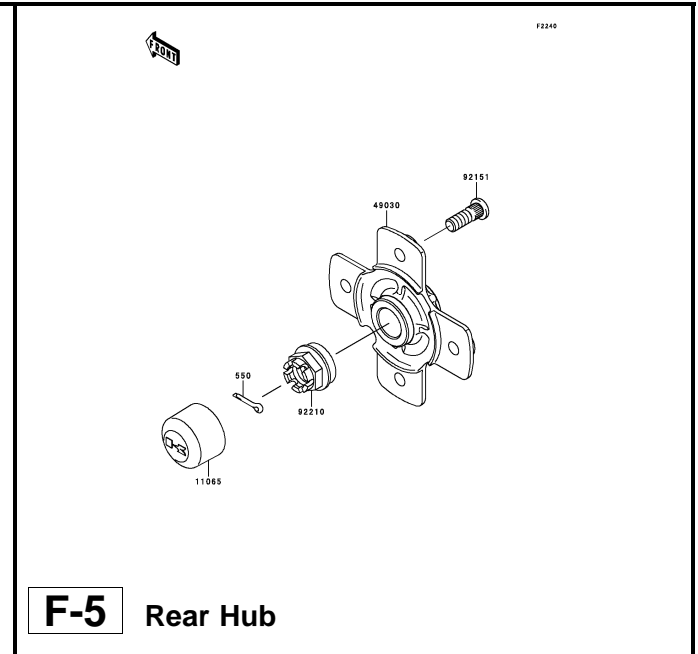
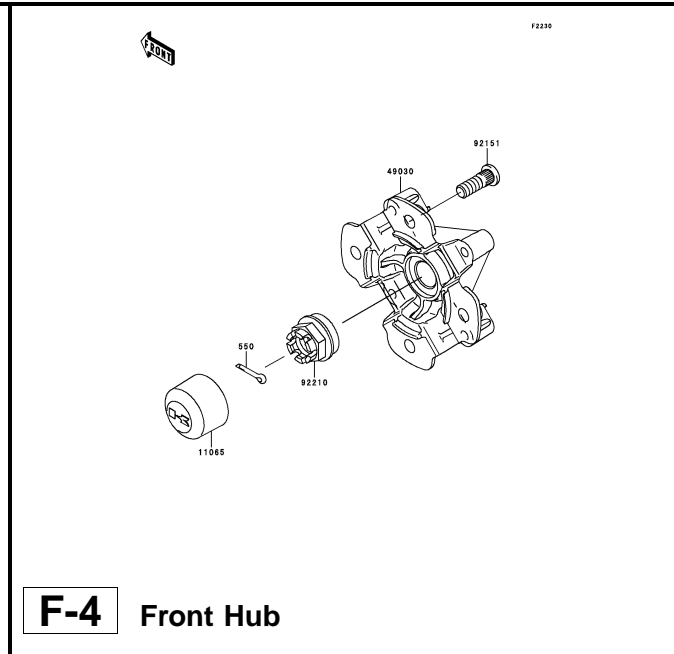
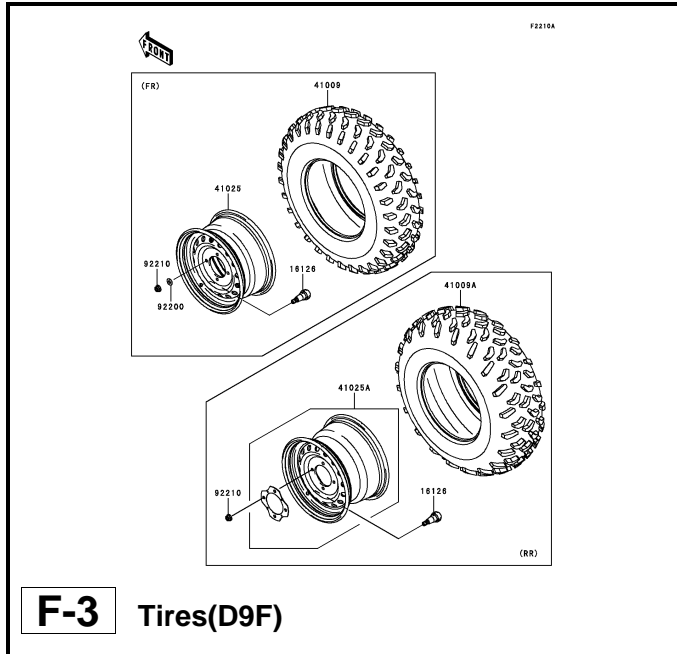

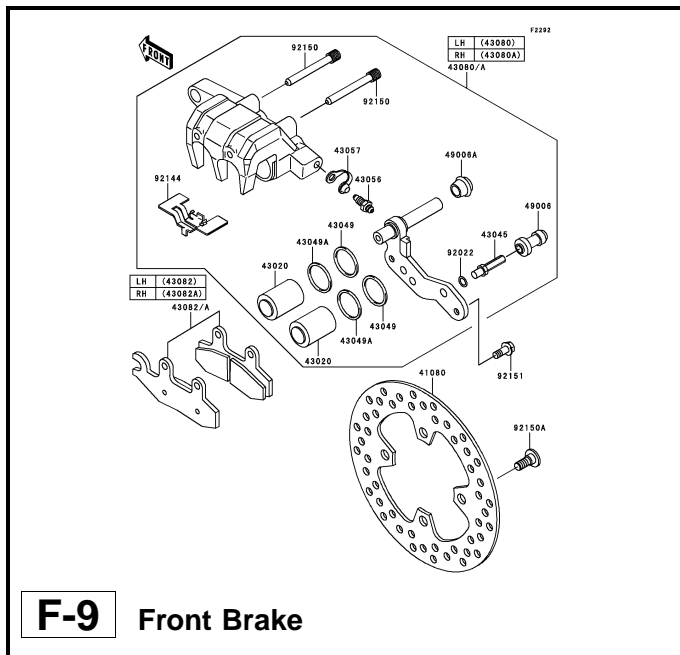

F-9 Front Brake

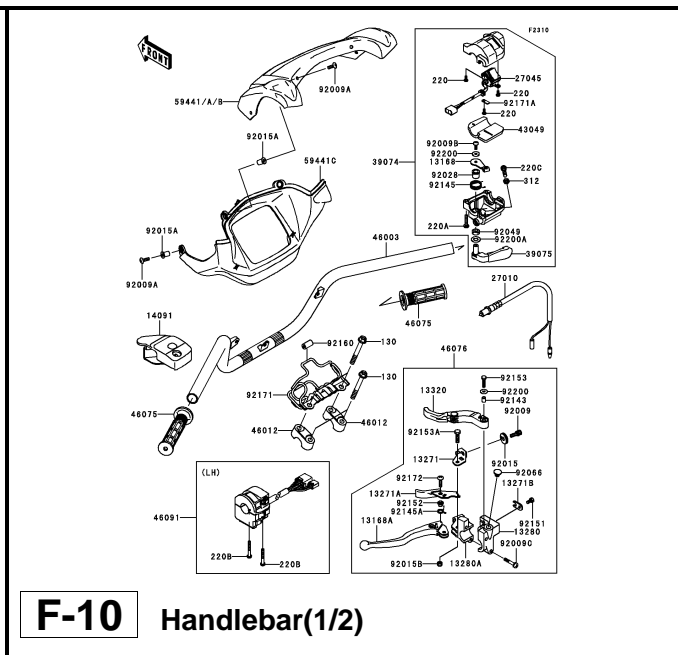

F-10 Handlebar(1/2)

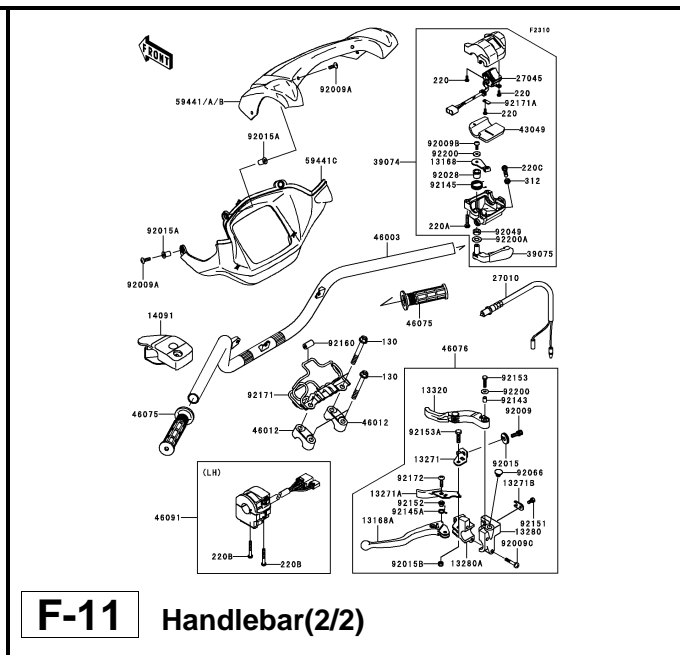

F-11 Handlebar(2/2)

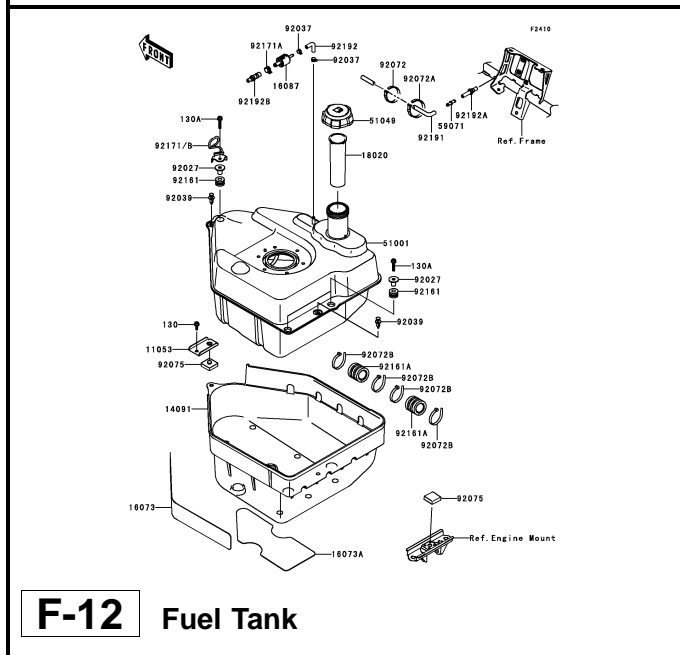

F-12 Fuel Tank

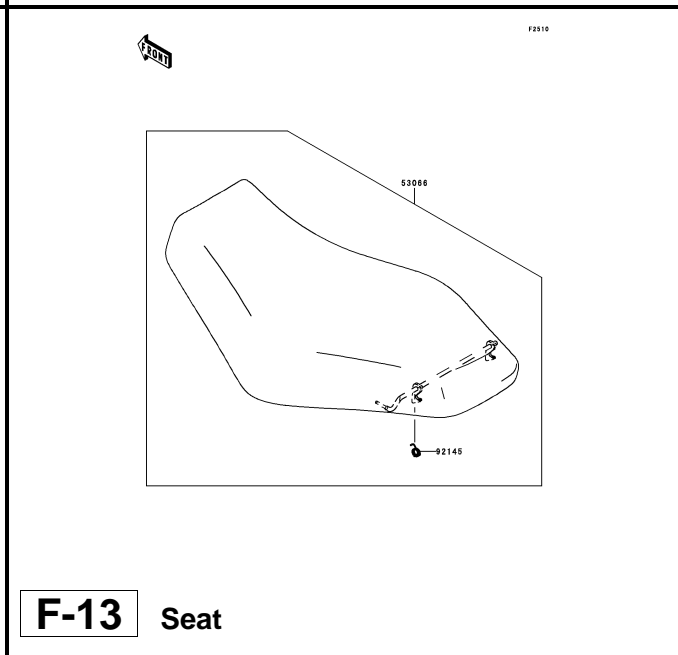

F-13 Seat

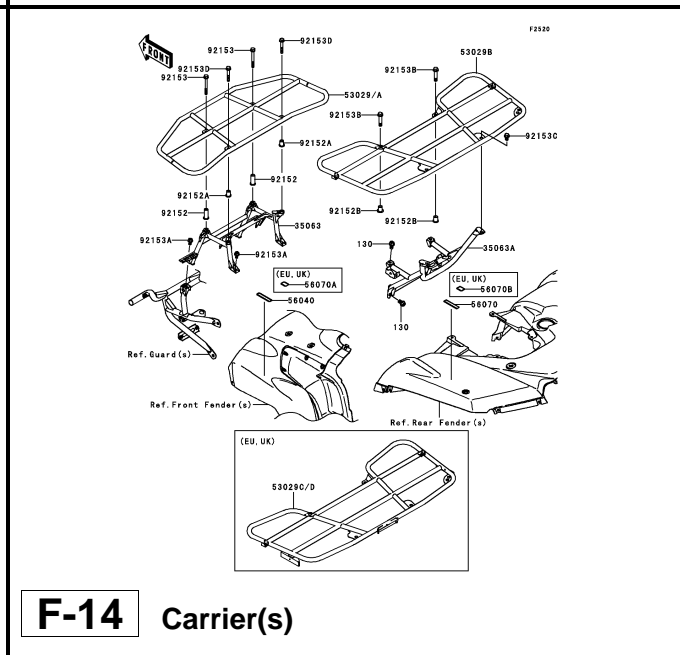

F-14 Carrier(s)

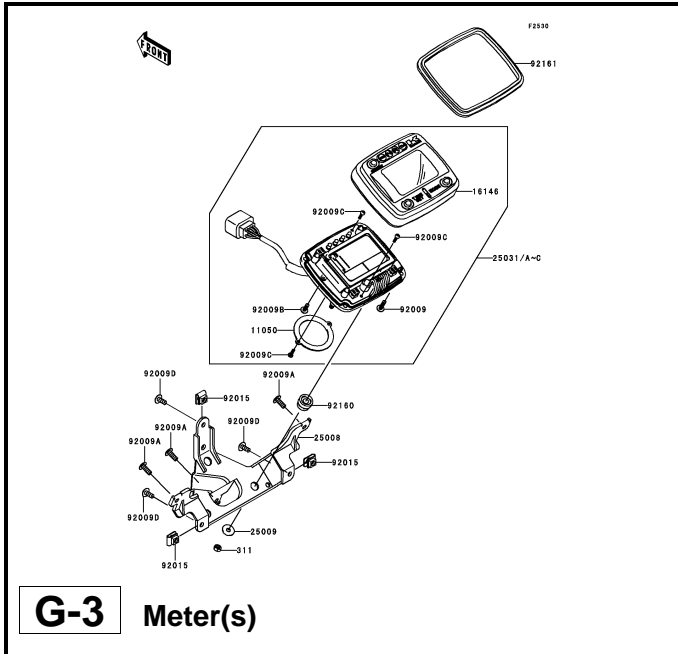

G-3 Meter(s)

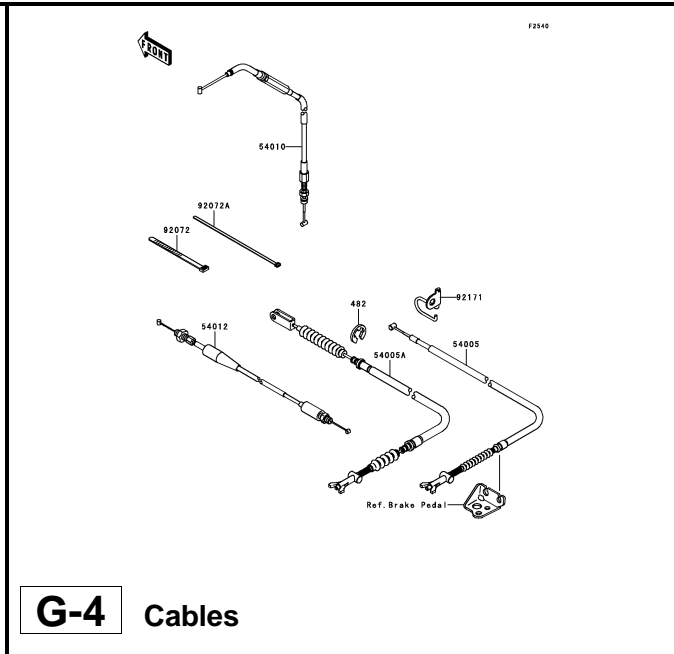

G-4 Cables

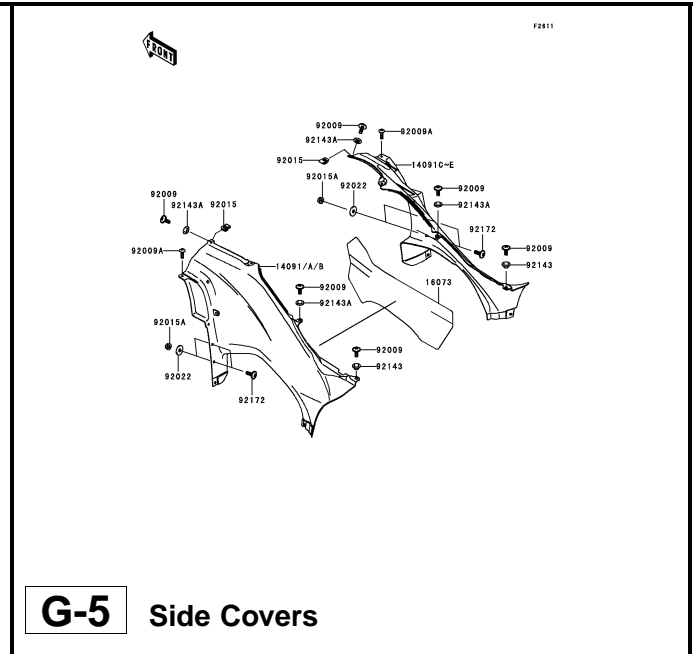

G-5 Side Covers

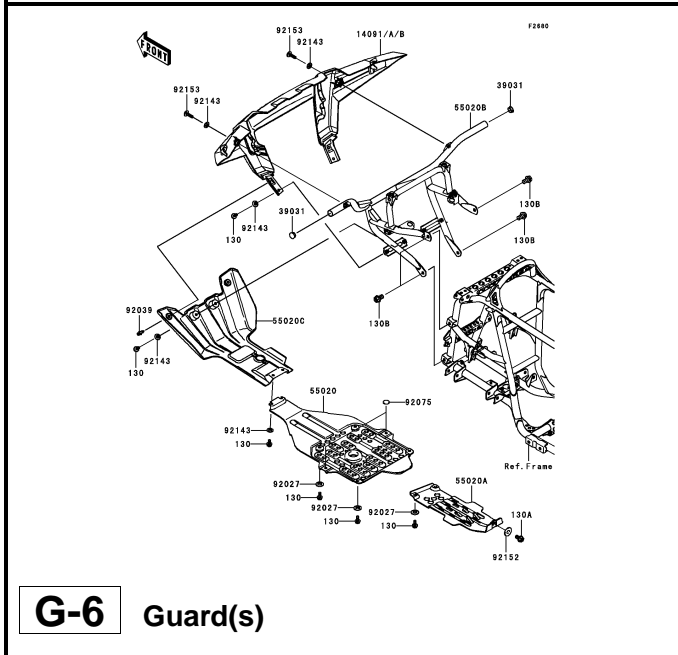

G-6 Guard(s)

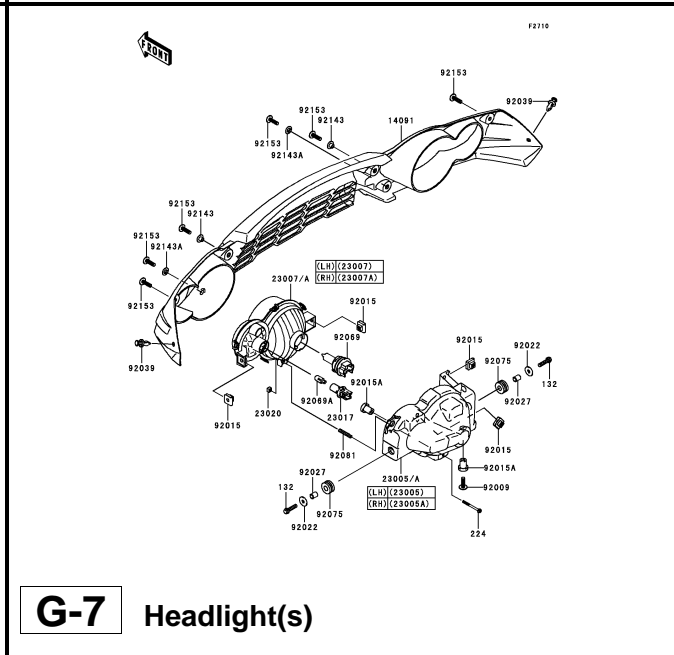

G-7 Headlight(s)

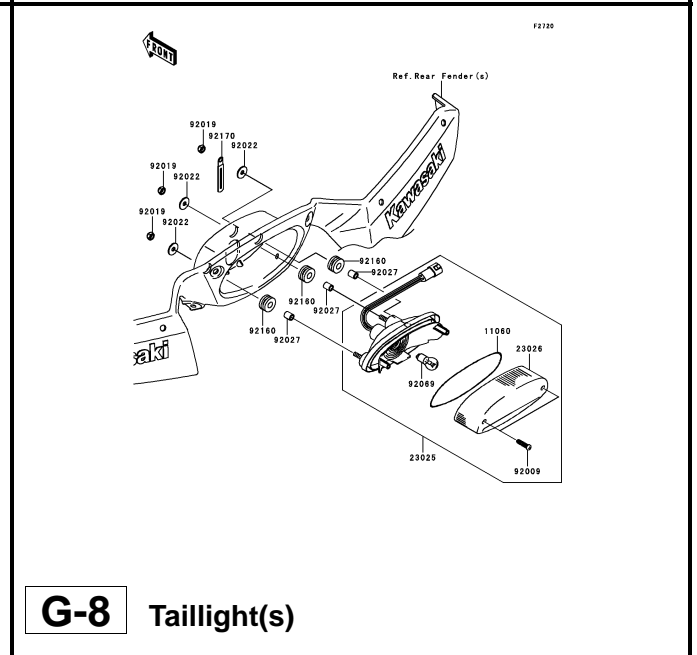

G-8 Taillight(s)

This catalog covers:

'08~'09 KVF750 D8F/D9F Chassis

GRID NO.

G-2

This grid covers:

Pictorial Index

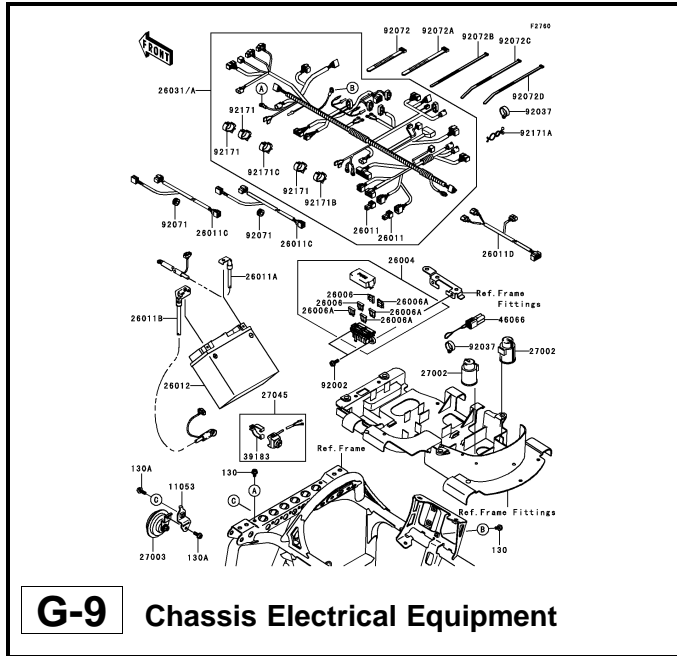

G-9 Chassis Electrical Equipment

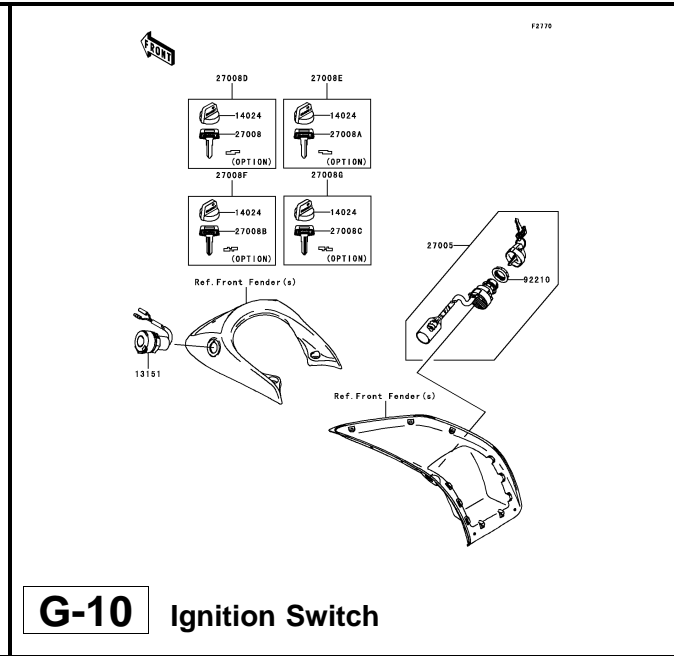

G-10 Ignition Switch

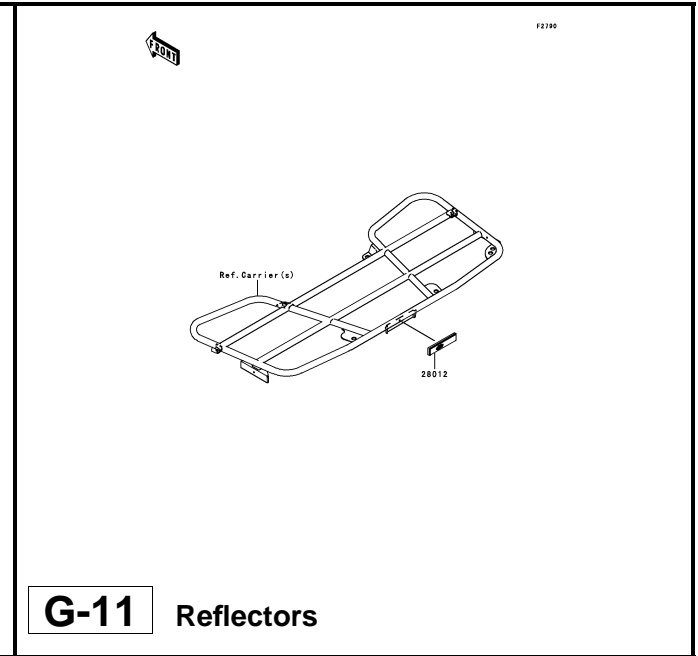

G-11 Reflectors

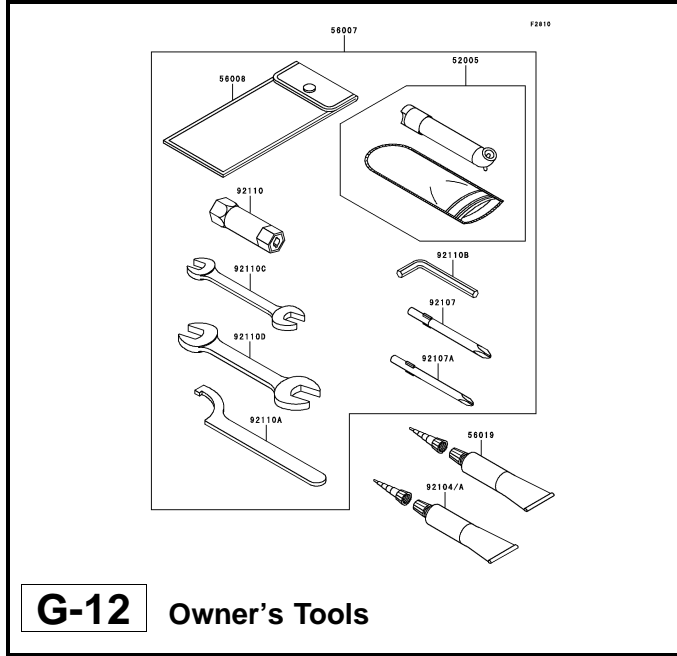

G-12 Owner's Tools

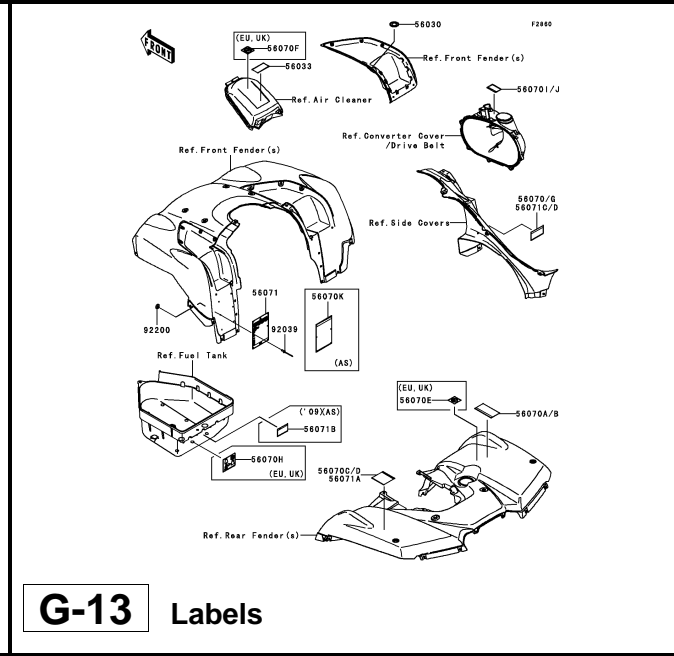

G-13 Labels

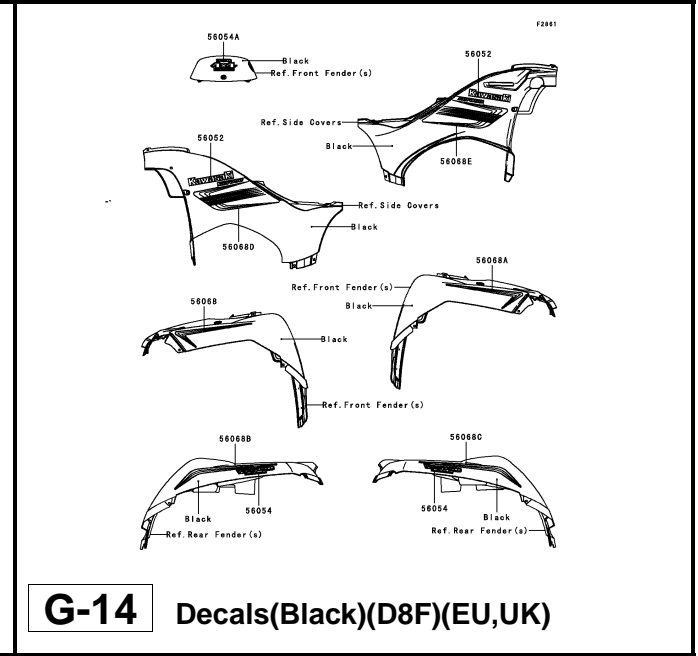

G-14 Decals(Black)(D8F)(EU,UK)

This catalog covers:

'08~'09 KVF750 D8F/D9F Chassis

GRID NO.

H-1

This grid covers:

Pictorial Index

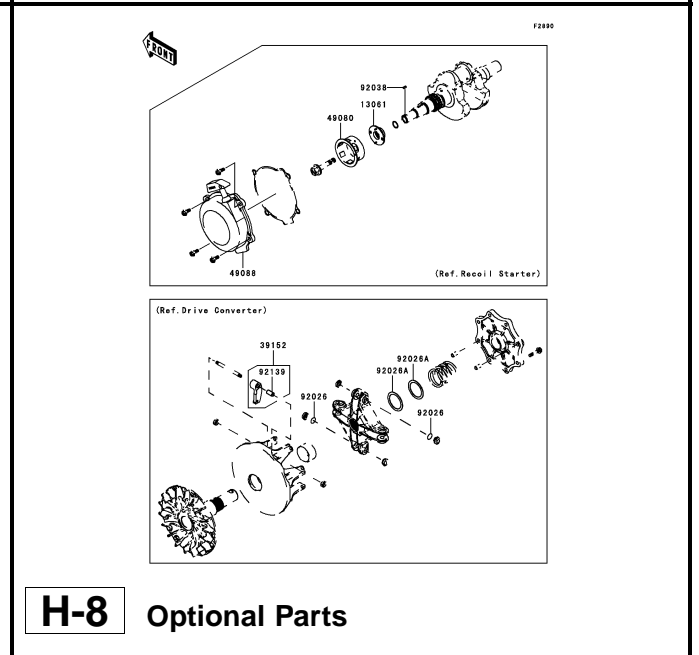
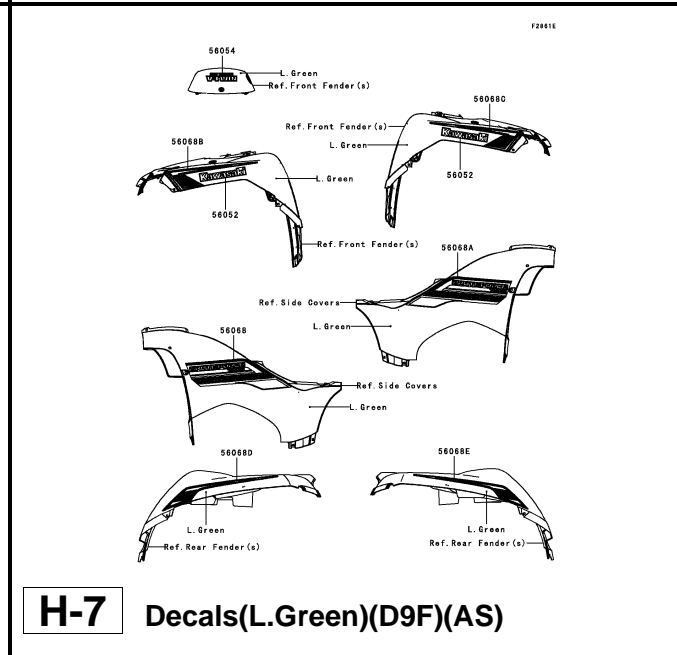
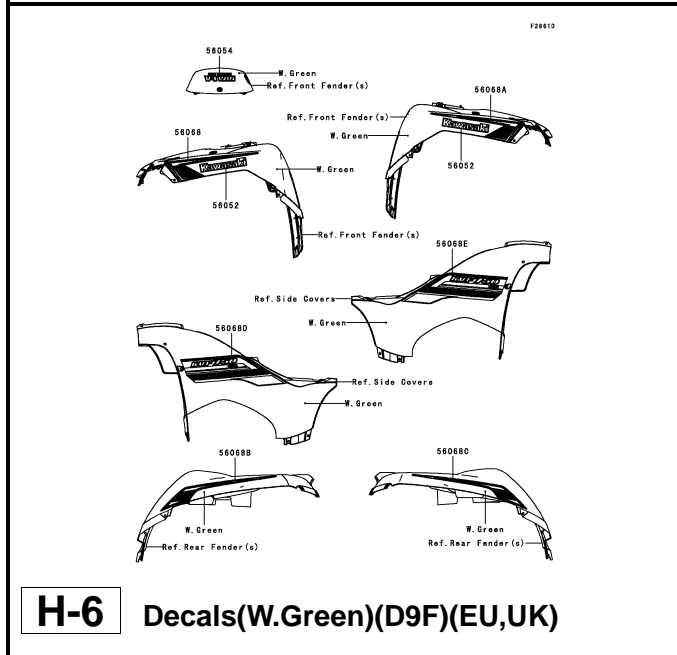
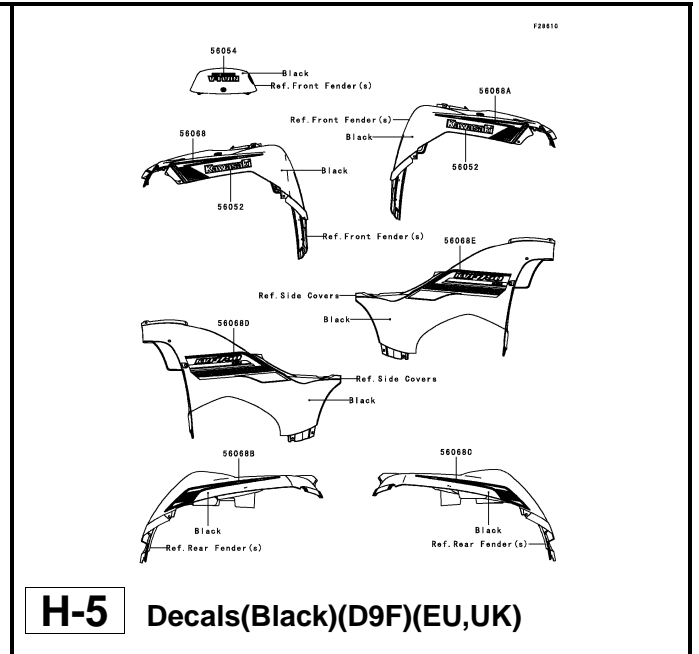
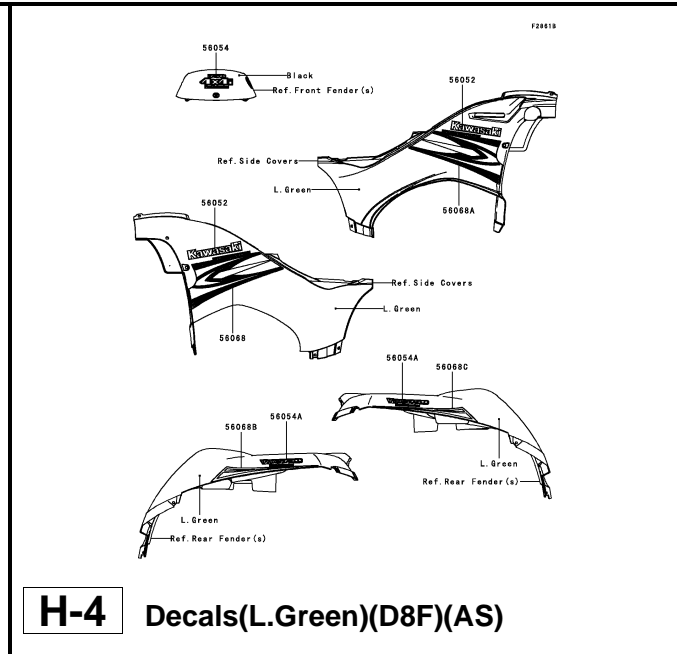
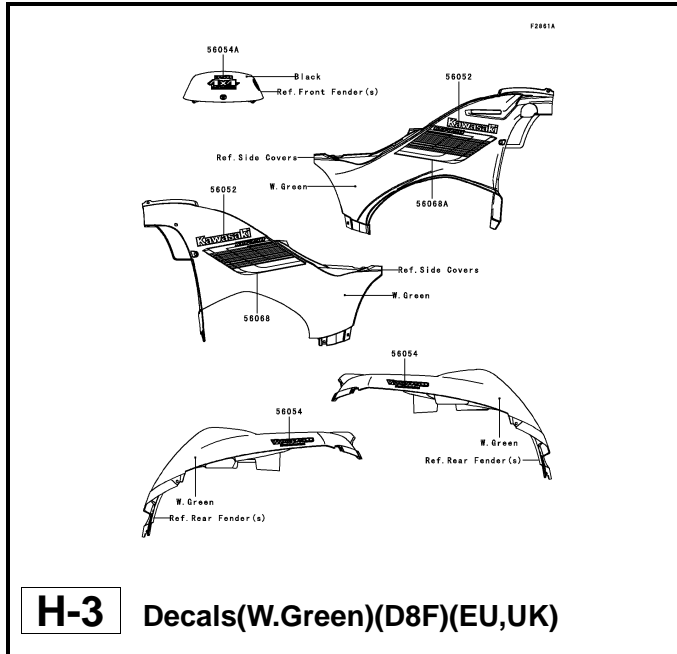

This catalog covers:

'08~'09 KVF750 D8F/D9F Chassis

GRID NO.

H-2

This grid covers:

Pictorial Index

F2920

Owner's Manual
(Local Procurement)

99923/A
99947/A
99972/A
99977/A
99984/A
99992/A

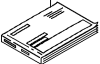

Ref. No.	Language
(99923/A)	German
(99947/A)	French
(99972/A)	Spanish
(99977/A)	English
(99984/A)	Dutch
(99992/A)	Italian

H-9 Manual(EU,UK)

This catalog covers:

'08~'09 KVF750 D8F/D9F Engine

GRID NO.

B-3

This grid covers:

Cylinder Head

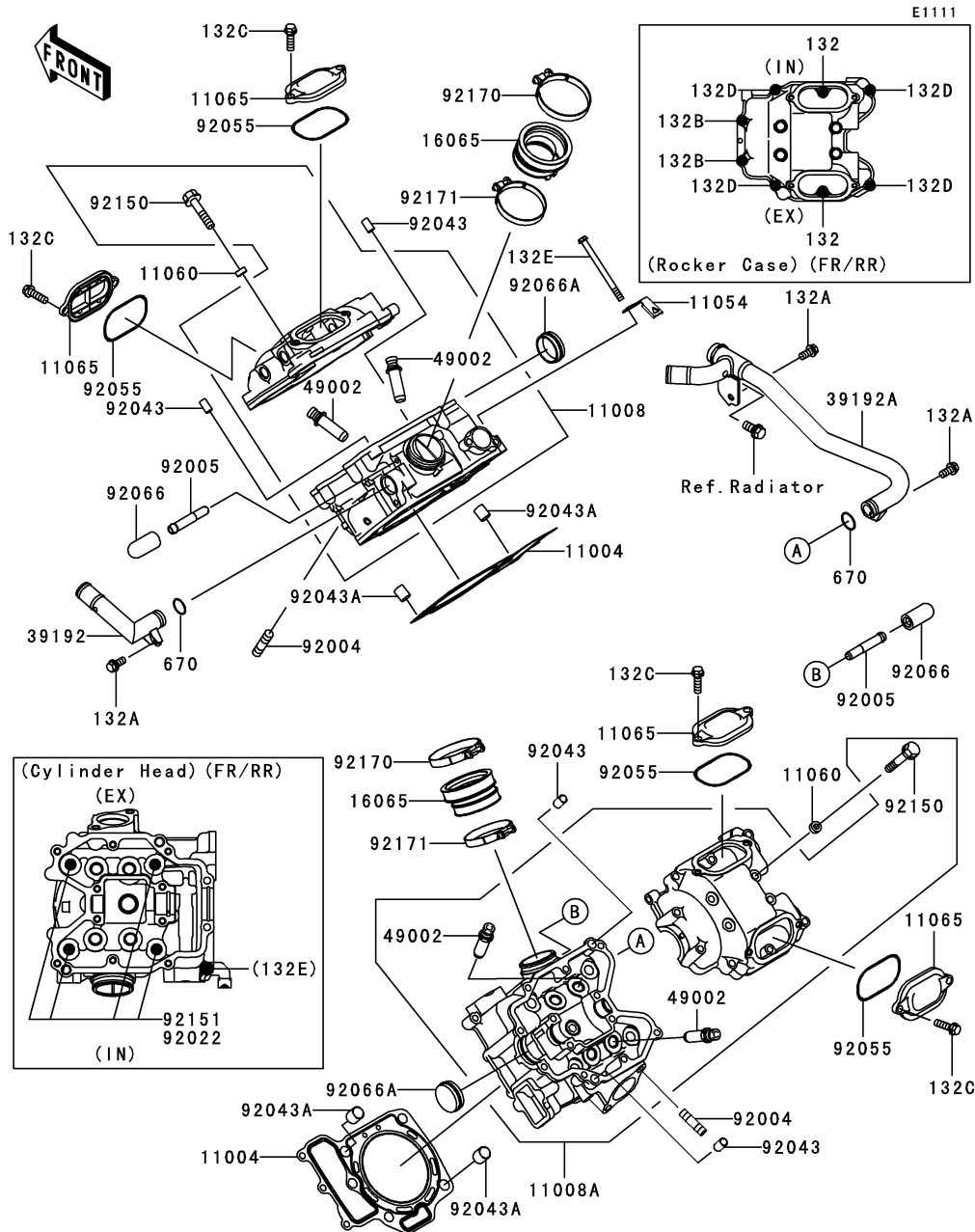

Ref. No.	Part No.	Description	Quantity-KVF750			
			Spec Code		'08	'09
			D8F	D9F		
11004	11004-0011	GASKET-HEAD			2	2
11008	11008-0087	HEAD-COMP-CYLINDER,FR			1	1
11008A	11008-0088	HEAD-COMP-CYLINDER,RR			1	1
11054	11054-1468	BRACKET			1	1
11060	11060-1994	GASKET,6.2X12X0.3			8	8
11065	11065-1152	CAP,ROCKER CASE			4	4
16065	16065-0046	HOLDER-CARBURETOR			2	2
39192	39192-0033	PIPE-WATER,FR			1	1
39192A	39192-0034	PIPE-WATER,RR			1	1
49002	49002-1097	GUIDE-VALVE			AR	AR
92004	92004-1217	STUD,8X22			4	4
92005	92005-1264	FITTING			2	2
92022	92022-1720	WASHER,11.5X20.5X1.6			8	8
92043	92043-1263	PIN,6.2X8X14			4	4
92043A	92043-4009	PIN,10.1X12X14			4	4
92055	92055-0112	RING-O			4	4
92066	92066-0095	PLUG			2	2
92066A	92066-1289	PLUG			2	2
92150	92150-1302	BOLT,FLANGED,6X55			8	8
92151	92151-1917	BOLT,FLANGED,10X150			8	8
92170	92170-1448	CLAMP			2	2
92171	92171-0722	CLAMP			2	2
132	132BA0625	BOLT-FLANGED-SMALL,6X25			4	4
132A	132BD0612	BOLT-FLANGED-SMALL,6X12			3	3
132B	132BD06130	BOLT-FLANGED-SMALL,6X130			4	4
132C	132BD0620	BOLT-FLANGED-SMALL,6X20			8	8
132D	132BD0630	BOLT-FLANGED-SMALL,6X30			8	8
132E	132BD0695	BOLT-FLANGED-SMALL,6X95			2	2
670	670B2016	O RING,16MM			2	2

This catalog covers:

'08~'09 KVF750 D8F/D9F Engine

GRID NO.

B-4

This grid covers:

Cylinder/Piston(s)

E1120

Ref. No.	Part No.	Description	Quantity-KVF750			
			'08	'09		
			D8F	D9F		
11005	11005-0022	CYLINDER-ENGINE,FR	1	1		
11005A	11005-0023	CYLINDER-ENGINE,RR	1	1		
11061	11061-0063	GASKET,CYLINDER BASE	2	2		
13001	13001-0021	PISTON-ENGINE	2	2		
13002	13002-1060	PIN-PISTON	2	2		
13008	13008-0008	RING-SET-PISTON	2	2		
92022	92022-304	WASHER,6.2X11X1	2	2		
92033	92033-1207	RING-SNAP	4	4		
92043	92043-4009	PIN,10.1X12X14	4	4		
132	132BD0612	BOLT-FLANGED-SMALL,6X12	2	2		
132A	132BD0630	BOLT-FLANGED-SMALL,6X30	2	2		
132B	132BD0640	BOLT-FLANGED-SMALL,6X40	4	4		

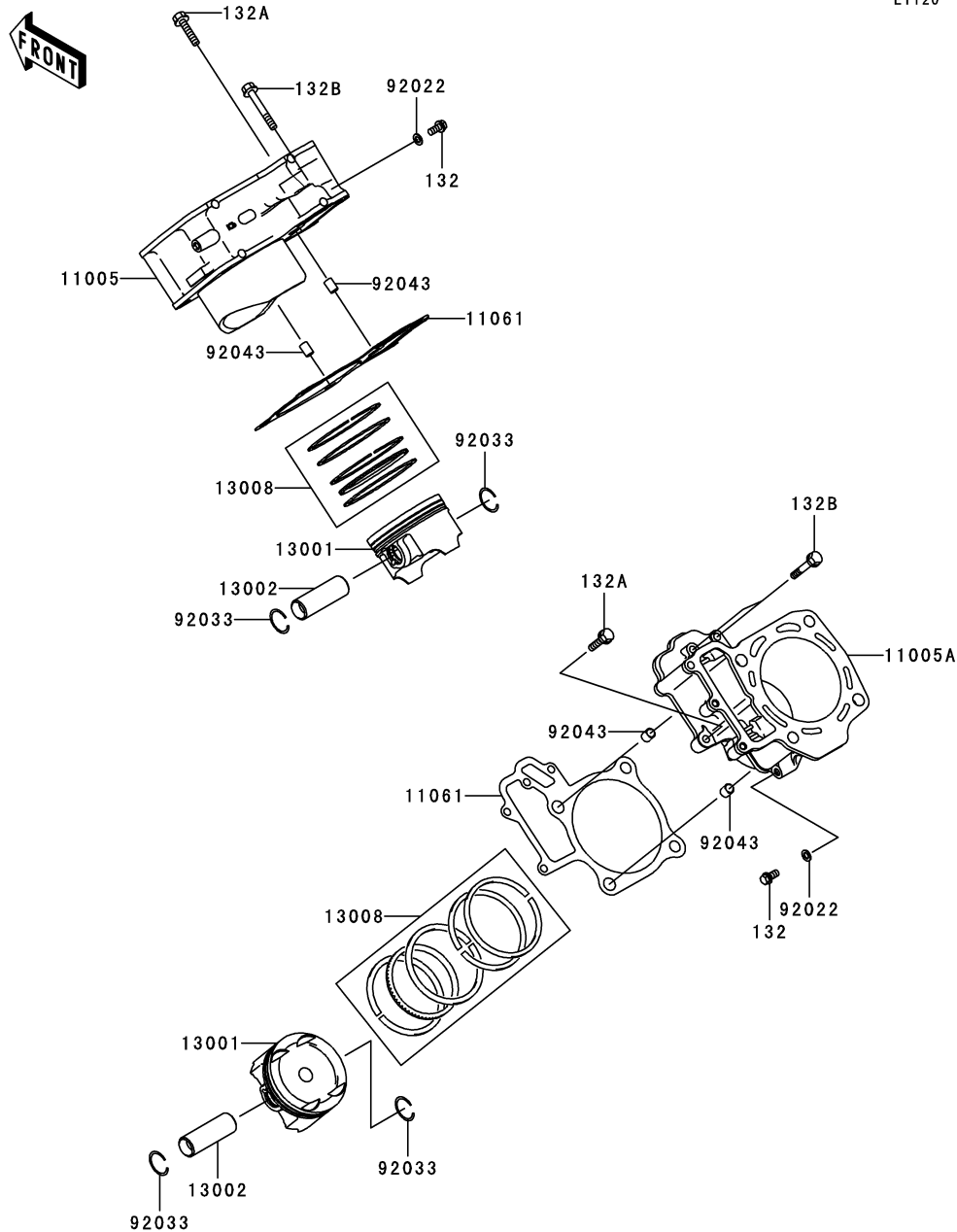

This catalog covers:

'08~'09 KVF750 D8F/D9F Engine

GRID NO.

B-5

This grid covers:

Air Cleaner

E1130

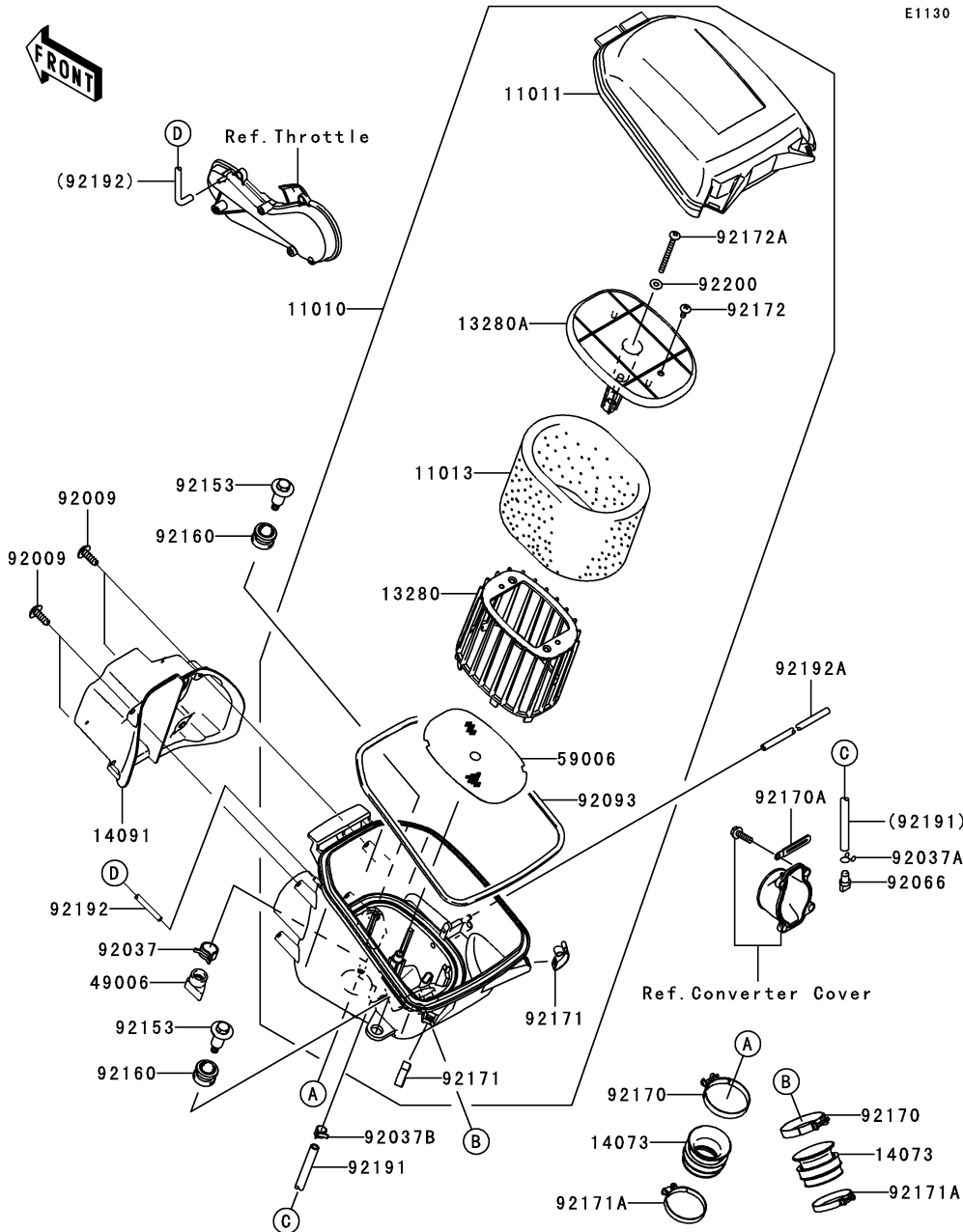

Ref. No.	Part No.	Description	Spec Code	Quantity-KVF750			
				'08	'09		
				D8F	D9F		
11010	11010-0152-6Z	FILTER-ASSY-AIR,F.BLACK	1	1			
11011	11011-0017-6Z	CASE-AIR FILTER,UPP,F.BLACK	1	1			
11013	11013-0021	ELEMENT-AIR FILTER	1	1			
13280	13280-0232	HOLDER	1	1			
13280A	13280-0233	HOLDER	1	1			
14073	14073-0160	DUCT	2	2			
14091	14091-0164	COVER,FR	1	1			
49006	49006-1292	BOOT	1	1			
59006	59006-0015	ARRESTER-FLAME	1	1			
92009	92009-1113	SCREW,TAPPING	4	4			
92037	92037-1460	CLAMP,HOSE CLIP	1	1			
92037A	92037-147	CLAMP,TUBE	1	1			
92037B	92037-1505	CLAMP,TUBE	1	1			
92066	92066-1211	PLUG,DRAIN	1	1			
92093	92093-0083	SEAL	1	1			
92153	92153-1052	BOLT,FLANGED,6X28.7	2	2			
92160	92160-1594	DAMPER	2	2			
92170	92170-1448	CLAMP	2	2			
92170A	92170-1514	CLAMP	1	1			
92171	92171-0225	CLAMP	2	2			
92171A	92171-0722	CLAMP	2	2			
92172	92172-0297	SCREW	1	1			
92172A	92172-0300	SCREW	1	1			
92191	92191-1531	TUBE,7X11X470	1	1			
92192	92192-0448	TUBE	1	1			
92192A	92192-0449	TUBE	1	1			
92200	92200-0364	WASHER	1	1			

This catalog covers:

'08~'09 KVF750 D8F/D9F Engine

GRID NO.

B-6

This grid covers:

Muffler(s)

E1140

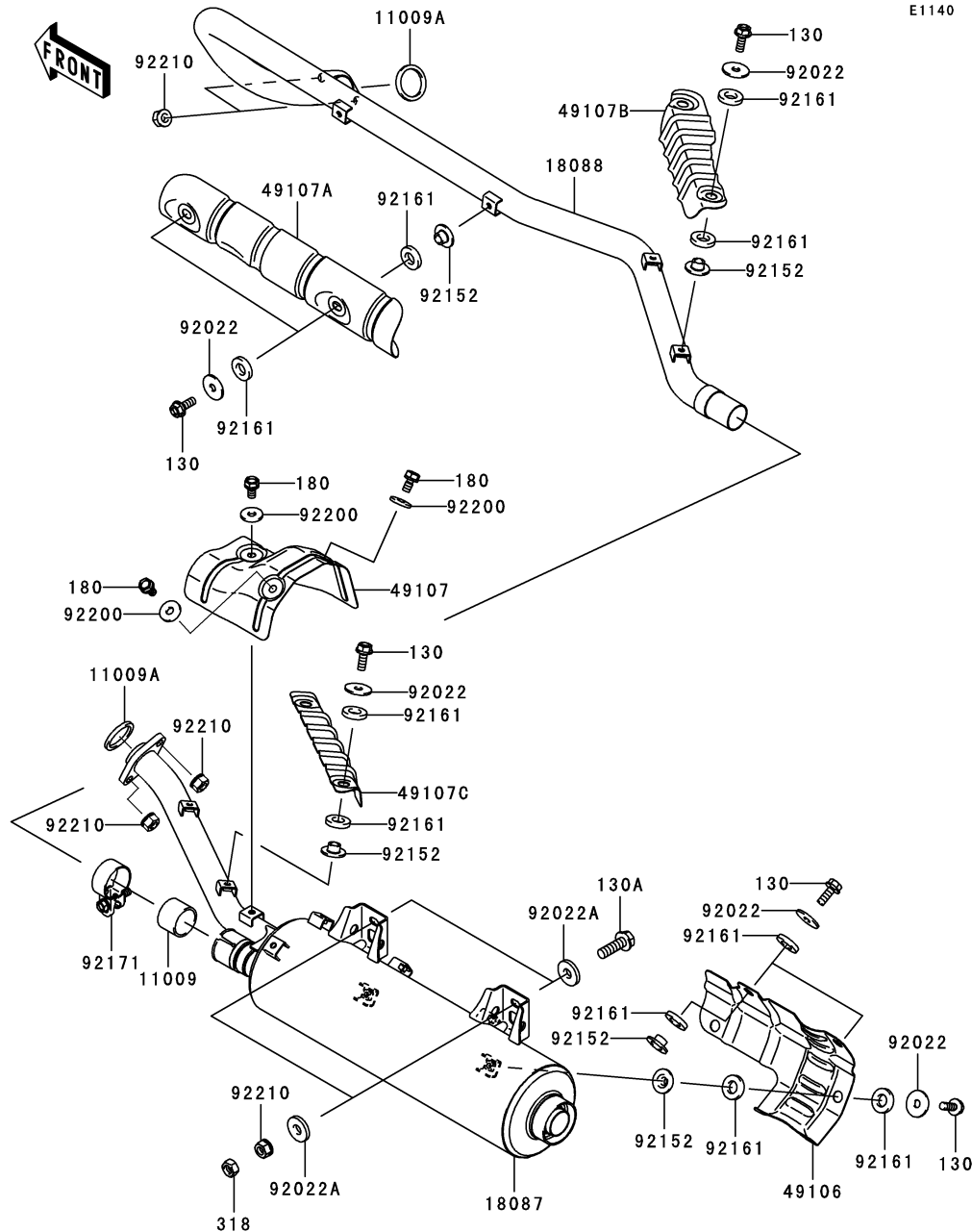

Ref. No.	Part No.	Description	Spec Code	Quantity-KVF750			
				'08	'09		
				D8F	D9F		
11009	11009-1865	GASKET,MUFFLER CONNECTING	1	1			
11009A	11009-1894	GASKET,EXHAUST HOLDER	2	2			
18087	18087-0167	MUFFLER	1	1			
18088	18088-0379	PIPE-EXHAUST	1	1			
49106	49106-0048	COVER-MUFFLER	1	1			
49107	49107-0050	COVER-EXHAUST PIPE,RR	1	1			
49107A	49107-0065	COVER-EXHAUST PIPE,FR	1	1			
49107B	49107-0066	COVER-EXHAUST PIPE,MIDDLE LH	1	1			
49107C	49107-0067	COVER-EXHAUST PIPE,MIDDLE RH	1	1			
92022	92022-237	WASHER,6.5X22X1.6	10	10			
92022A	92022-276	WASHER,8.5X22X3.2	4	4			
92152	92152-0423	COLLAR	10	10			
92161	92161-0319	DAMPER	20	20			
92171	92171-1330	CLAMP	1	1			
92200	92200-2035	WASHER,6.5X18X2.0	3	3			
92210	92210-1242	NUT,8MM	6	6			
130	130BD0616	BOLT-FLANGED,6X16	10	10			
130A	130CD0825	BOLT-FLANGED,8X25	2	2			
180	180BD0612	BOLT-UPSET-WS,6X12	3	3			
318	318BA0800	NUT-HEX-SMALL,8MM	2	2			

This catalog covers:

'08~'09 KVF750 D8F/D9F Engine

GRID NO.

B-7

This grid covers:

Valve(s)

E1210

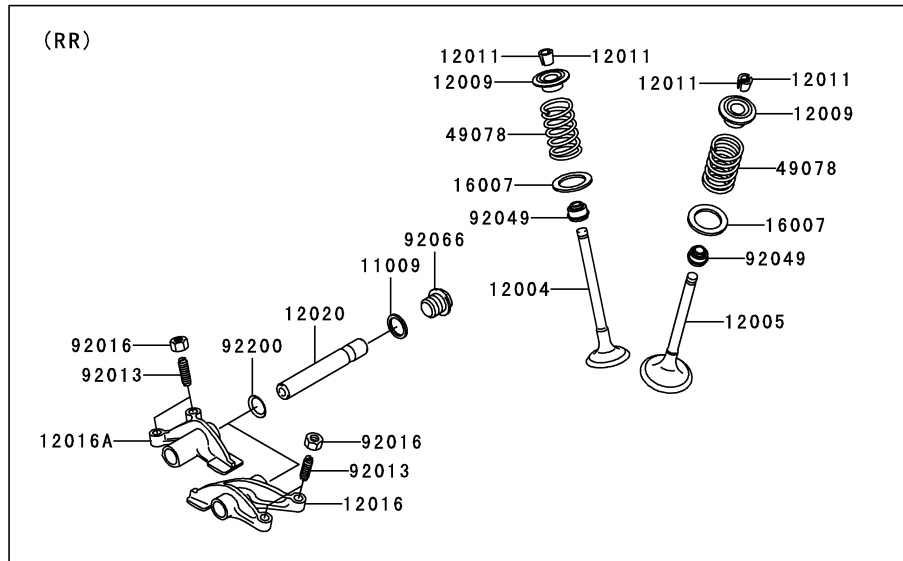
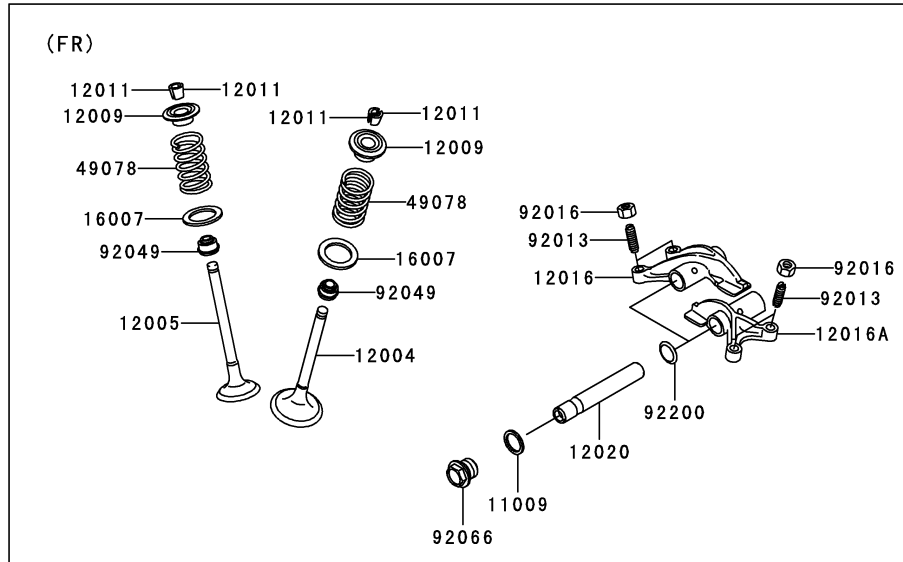

Ref. No.	Part No.	Description	Spec Code	Quantity-KVF750		
				'08	'09	
			D8F	D9F		
11009	11009-1430	GASKET,14X18X1.5	4	4		
12004	12004-0007	VALVE-INTAKE	4	4		
12005	12005-0047	VALVE-EXHAUST	4	4		
12009	12009-1056	RETAINER-VALVE SPRING	8	8		
12011	12011-1051	COLLET	16	16		
12016	12016-1128	ARM-ROCKER,EXHAUST	2	2		
12016A	12016-1129	ARM-ROCKER,INTAKE	2	2		
12020	12020-0004	SHAFT-ROCKER	4	4		
16007	16007-1178	SEAT-SPRING,17.5X23.8X0.5	8	8		
49078	49078-0014	SPRING-ENGINE VALVE	8	8		
92013	92013-009	SCREW,6MM	8	8		
92016	92016-061	NUT,6MM	8	8		
92049	92049-1218	SEAL-OIL,VSB58.558	8	8		
92066	92066-2196	PLUG,DRAIN	4	4		
92200	92200-1508	WASHER,13X17X0.3	4	4		

This catalog covers:

'08~'09 KVF750 D8F/D9F Engine

GRID NO.

B-8

This grid covers:

Camshaft(s)/Tensioner

E1230

Ref. No.	Part No.	Description	Spec Code	Quantity-KVF750			
				'08	'09		
				D8F	D9F		

11060	11060-1966	GASKET		1	1		
12046	12046-0021	SPROCKET,21T&17T		1	1		
12046A	12046-1203	SPROCKET,CAMSHAFT,34T		2	2		
12048	12048-1176	TENSIONER-ASSY,CAM		2	2		
12048A	12048-1177	TENSIONER-ASSY,SECONDARY		1	1		
12053	12053-1441	GUIDE-CHAIN,CAMSHAFT,TENSION		2	2		
12053A	12053-1442	GUIDE-CHAIN,CAMSHAFT,SLACK		2	2		
12053B	12053-1443	GUIDE-CHAIN,TENSION		1	1		
12053C	12053-1444	GUIDE-CHAIN,SLACK		1	1		
13042	13042-1141	WEIGHT,DECOMP		4	4		
13107	13107-0029	SHAFT		1	1		
13107A	13107-1443	SHAFT,CHAIN GUIDE,FR		1	1		
13107B	13107-1444	SHAFT,CHAIN GUIDE,RR		1	1		
14014	14014-1148	PLATE-POSITION,DRIVE		1	1		
49118	49118-0001	CAMSHAFT-COMP,FR		1	1		
49118A	49118-0002	CAMSHAFT-COMP,RR		1	1		
92033	92033-1039	RING-SNAP,8MM		1	1		
92055	92055-086	RING-O,18.8X1.9		2	2		
92057	92057-0073	CHAIN,DID SCR-0412 SDH		1	1		
92057A	92057-0074	CHAIN,DID SCR-0409 SDH		2	2		
92145	92145-1303	SPRING,DECOMP		2	2		
92153	92153-1200	BOLT,SOCKET,6X24.5		2	2		
120	120CA0610	BOLT-SOCKET,6X10		4	4		
120A	120CB0614	BOLT-SOCKET,6X14		2	2		
132	132BD0630	BOLT-FLANGED-SMALL,6X30		6	6		
410	410AA0800	WASHER-PLAIN-SMALL,8MM		1	1		
480	480J1400	CIRCLIP-TYPE-C,14MM		1	1		
482	482J5000	CIRCLIP-TYPE-E		4	4		

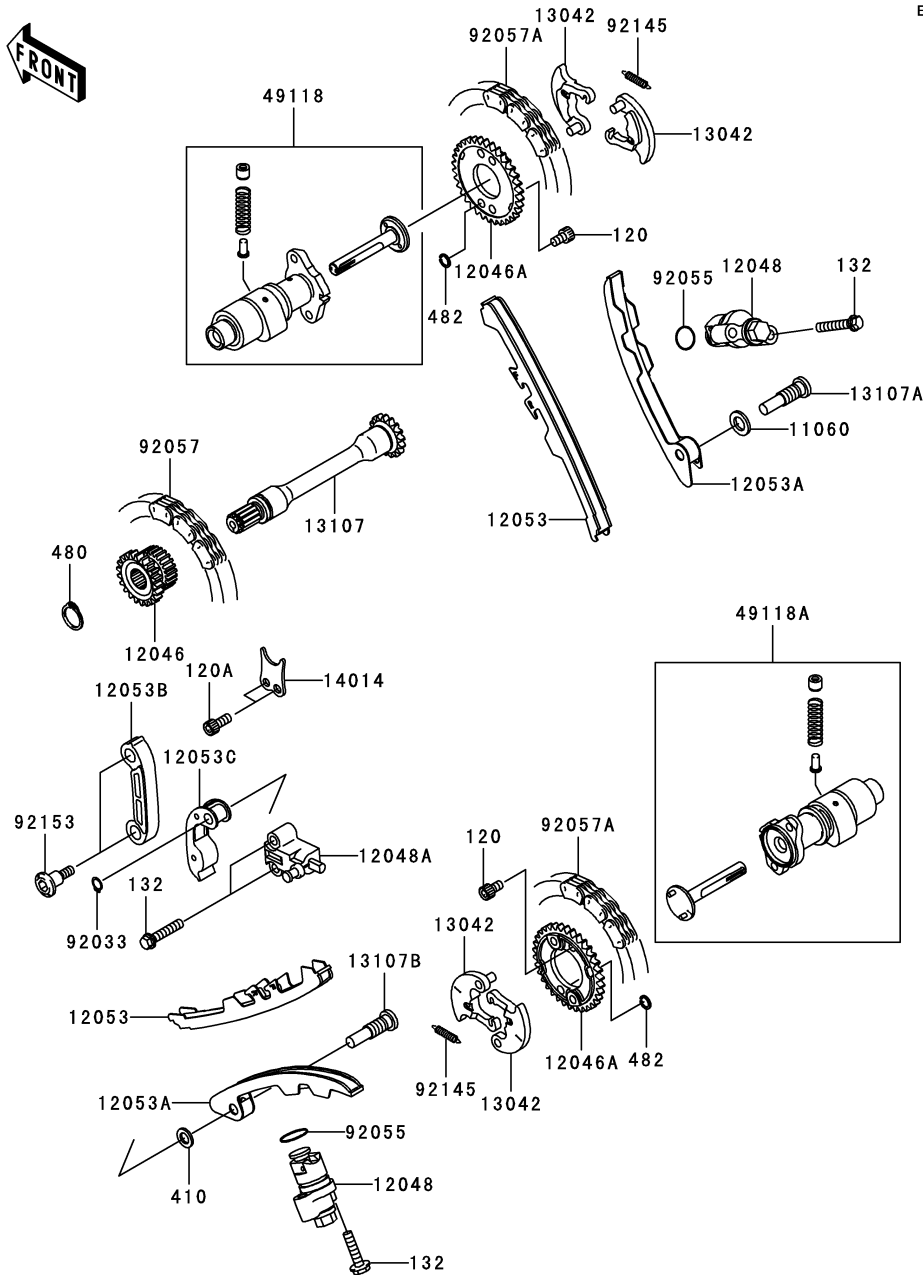

This catalog covers:

'08~'09 KVF750 D8F/D9F Engine

GRID NO.

B-9

This grid covers:

Crankshaft

E1321

Ref. No.	Part No.	Description	Spec Code	Quantity-KVF750			
				'08	'09		
				D8F	D9F		
13031	13031-0079	CRANKSHAFT-COMP	1	1			
13251	13251-1143	ROD-ASSY-CONNECTING	2	2			
92001	92001-1980	BOLT,CONNECTING ROD	4	4			
92015	92015-1311	NUT,FLANGED,8MM	4	4			
92028	92028-1961	BUSHING,CONNECTING ROD,GREEN	AR	AR			
92028A	92028-1962	BUSHING,CONNECTING ROD,YELLOW	4	4			
92028B	92028-1963	BUSHING,CONNECTING ROD,BROWN	AR	AR			

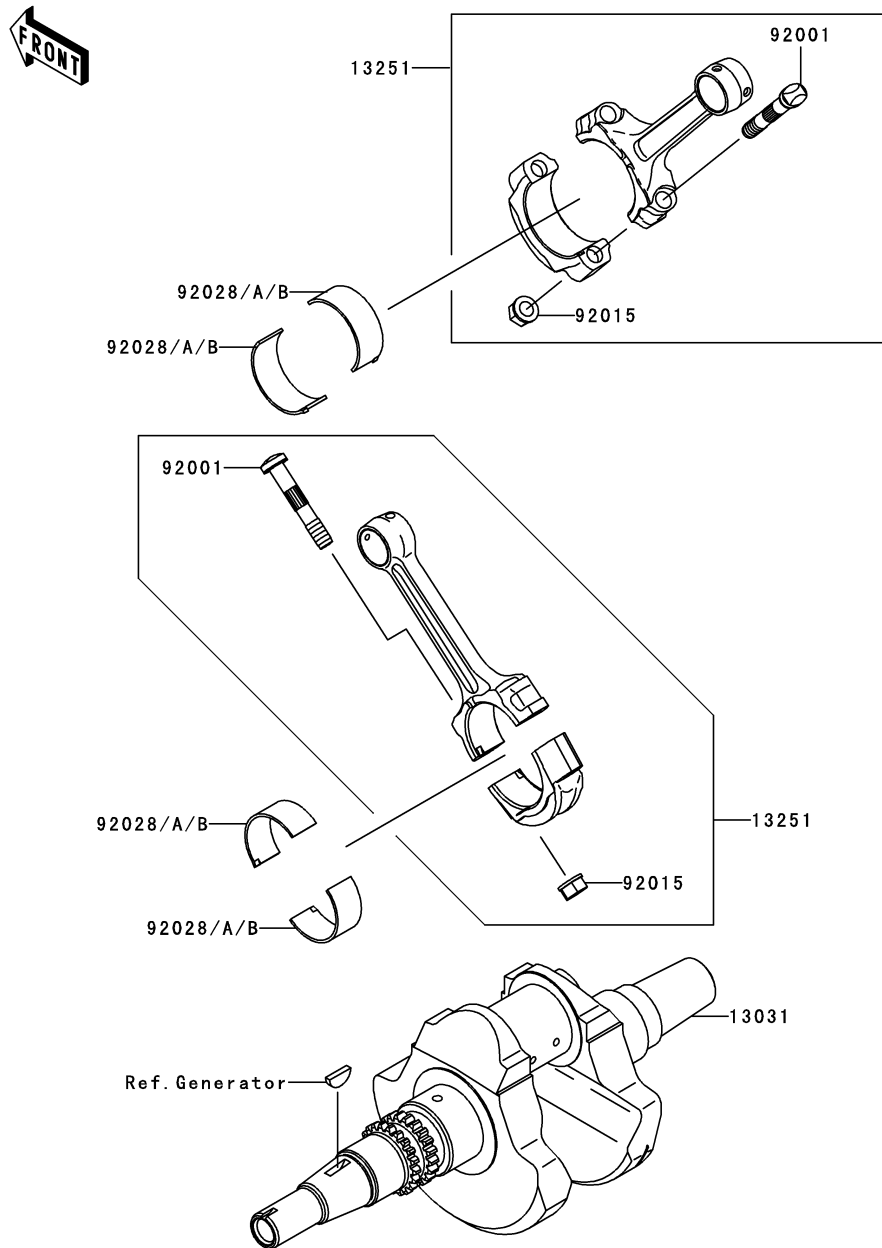

This catalog covers:

'08~'09 KVF750 D8F/D9F Engine

GRID NO.

B-10

This grid covers:

Transmission

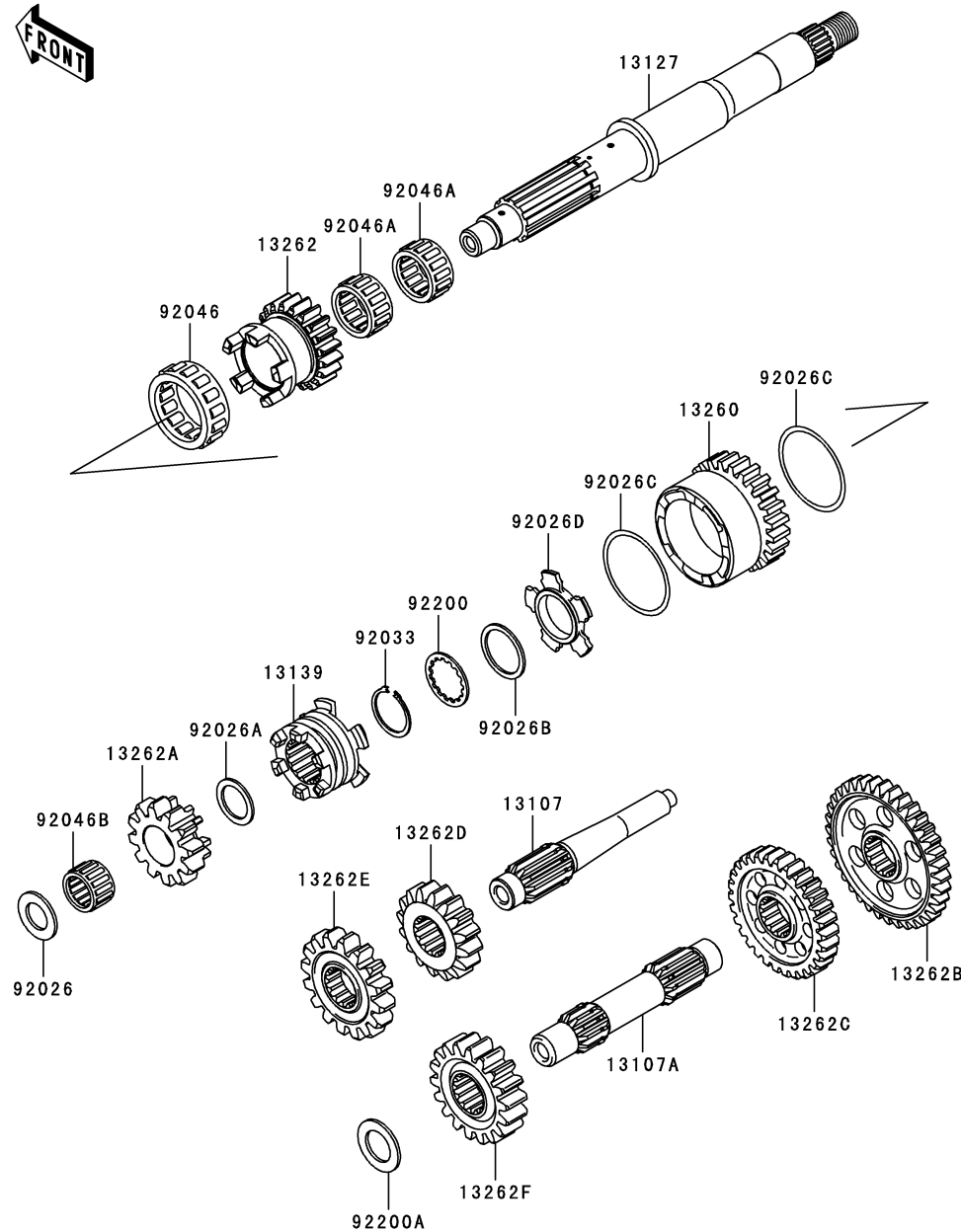

E1361

Ref. No.	Part No.	Description	Spec Code	Quantity-KVF750			
				'08	'09		
				D8F	D9F		
13107	13107-0158	SHAFT,REVERSE,IDLE	1	1			
13107A	13107-0177	SHAFT,COUNTER	1	1			
13127	13127-0053	SHAFT-TRANSMISSION INPUT	1	1			
13139	13139-0003	SHIFTER	1	1			
13260	13260-1867	GEAR,INPUT HIGH,26T	1	1			
13262	13262-0234	GEAR,INPUT LOW,20T	1	1			
13262A	13262-0235	GEAR,INPUT REVERSE,12T	1	1			
13262B	13262-0313	GEAR,DRIVEN LOW,36T	1	1			
13262C	13262-0314	GEAR,DRIVEN HI,30T	1	1			
13262D	13262-0433	GEAR,OUTPUT REVERSE,16T	1	1			
13262E	13262-0434	GEAR,DRIVEN REVERSE,16T	1	1			
13262F	13262-0491	GEAR,OUTPUT DRIVE,18T	1	1			
92026	92026-1415	SPACER,17.3X30X2.0	1	1			
92026A	92026-1568	SPACER,21.2X29X1.6	1	1			
92026B	92026-1587	SPACER,28.2X34.5X1.6	1	1			
92026C	92026-1599	SPACER,48.2X54.3X1.0	2	2			
92026D	92026-1600	SPACER,HI&LOW	1	1			
92033	92033-1037	RING-SNAP,25.9X30.6X1.2	1	1			
92046	92046-1276	BEARING-NEEDLE,HIGH GEAR	1	1			
92046A	92046-1278	BEARING-NEEDLE,FWF-283317	2	2			
92046B	92046-1279	BEARING-NEEDLE,REVERSE GEAR	1	1			
92200	92200-1240	WASHER,28.5X34.0X1.5	1	1			
92200A	92200-1351	WASHER,20.3X33X2.0	1	1			

This catalog covers:

'08~'09 KVF750 D8F/D9F Engine

GRID NO.

B-11

This grid covers:

Gear Change Mechanism



E1370

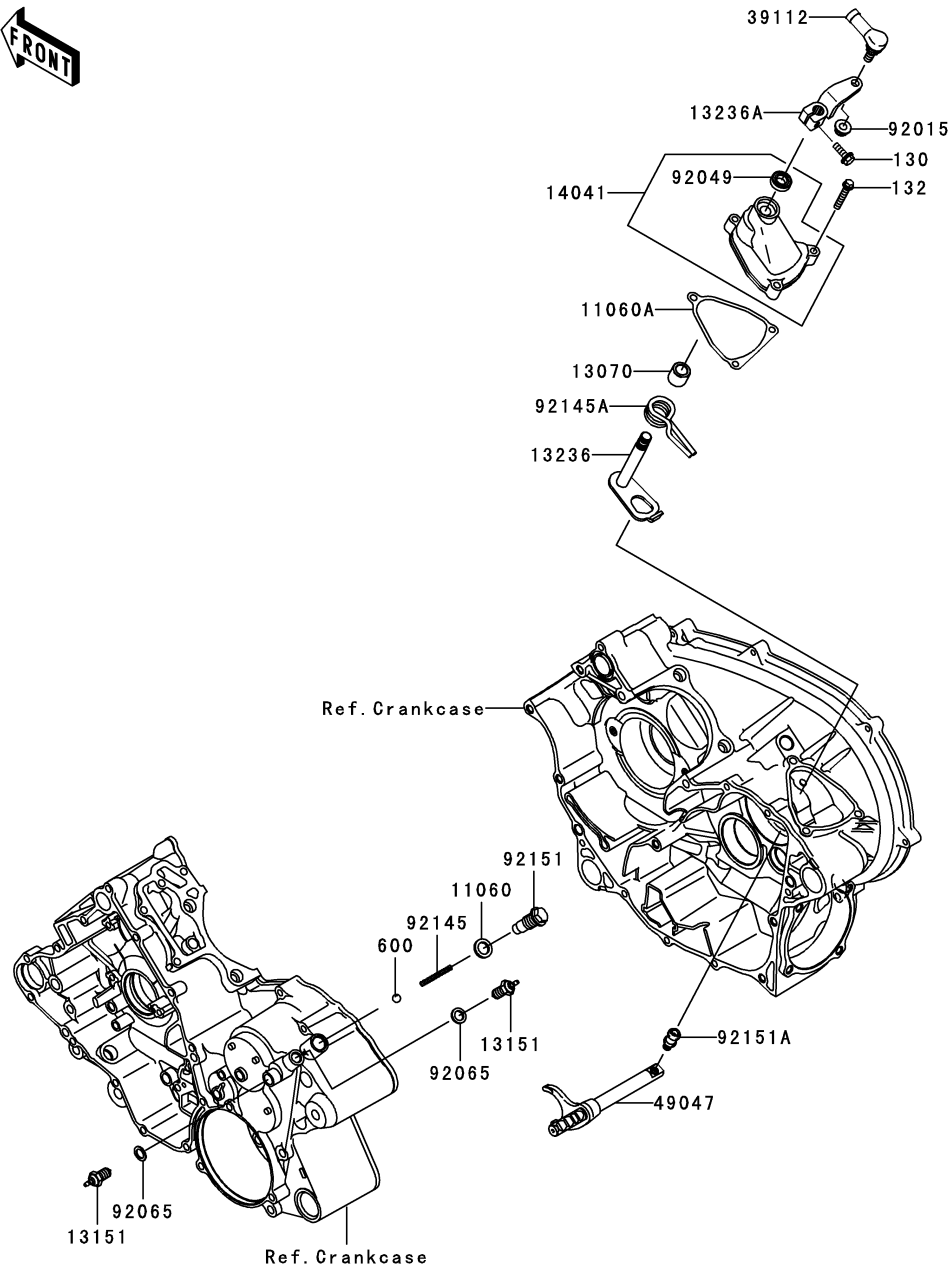

Ref. No.	Part No.	Description	Spec Code	Quantity-KVF750			
				'08	'09		
				D8F	D9F		
11060	11060-1287	GASKET,14X20X2	1	1			
11060A	11060-1956	GASKET,CHANGE LEVER COVER	1	1			
13070	13070-1352	GUIDE	1	1			
13151	13151-1080	SWITCH-COMP,NEUTRAL	2	2			
13236	13236-0051	LEVER-COMP,CHANGE	1	1			
13236A	13236-1343	LEVER-COMP,CHANGE LEVER	1	1			
14041	14041-1136	COVER-COMP,CHANGE LEVER	1	1			
39112	39112-1080	RODEND-TIE,CHANGE LEVER	1	1			
49047	49047-1104	ROD-SHIFT	1	1			
92015	92015-1432	NUT,8MM	1	1			
92049	92049-1271	SEAL-OIL,TB12205.5	1	1			
92065	92065-058	GASKET,10.5X16X1	2	2			
92145	92145-1297	SPRING,CHANGE POSITION	1	1			
92145A	92145-1299	SPRING,CHANGE LEVER	1	1			
92151	92151-1687	BOLT,CHANGE POSITION	1	1			
92151A	92151-1699	BOLT,SHIFT ROD	1	1			
130	130CD0620	BOLT-FLANGED,6X20	1	1			
132	132BD0630	BOLT-FLANGED-SMALL,6X30	3	3			
600	600A1000	BALL-STEEL,5/16"	1	1			

This catalog covers:

'08~'09 KVF750 D8F/D9F Engine

GRID NO.

B-12

This grid covers:

Drive Converter

E1391

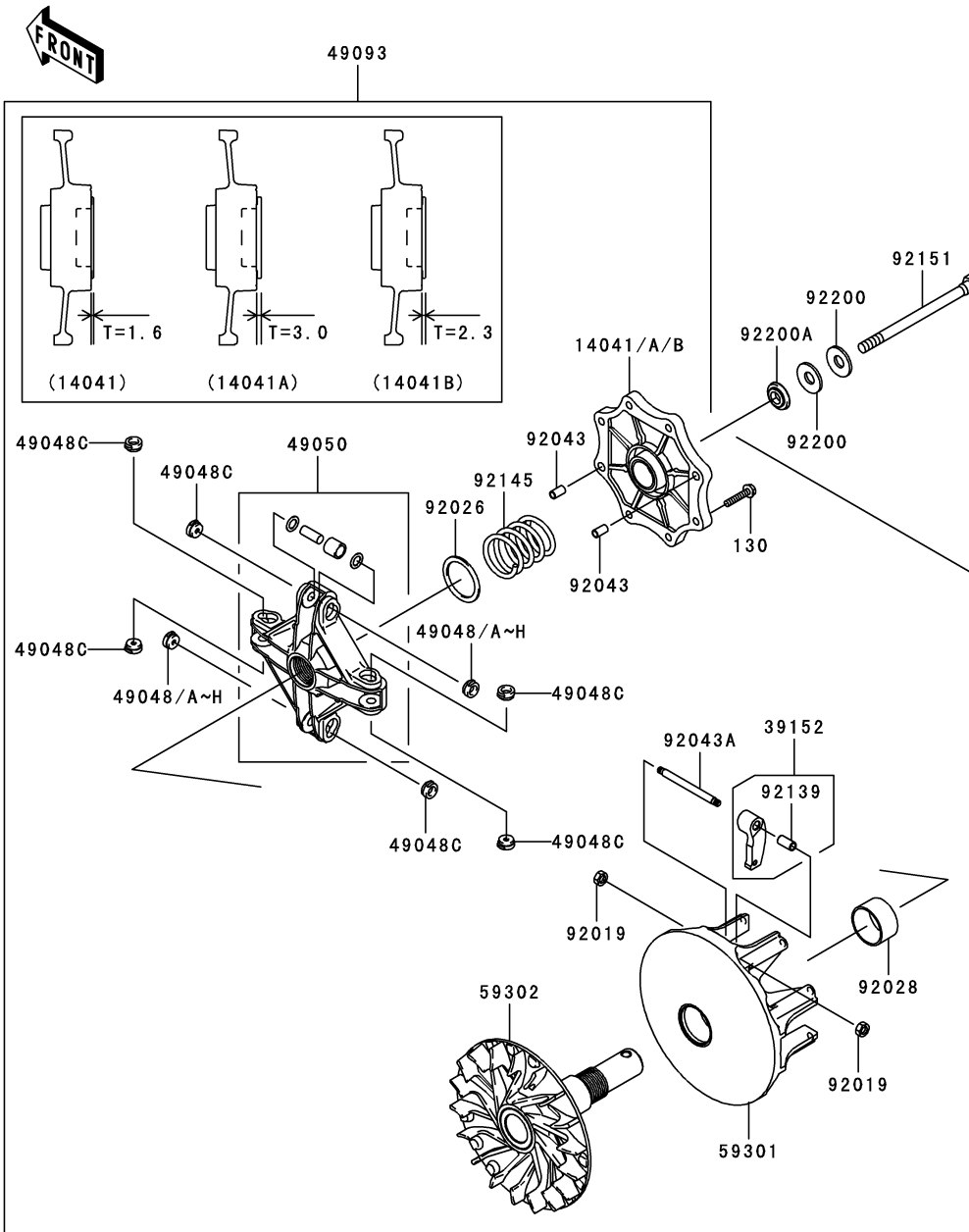

Ref. No.	Part No.	Description	Spec Code	Quantity-KVF750			
				'08	'09		
				D8F	D9F		
14041	14041-1159	COVER-COMP,RED	AR	AR			
14041A	14041-1160	COVER-COMP,BLUE	AR	AR			
14041B	14041-1161	COVER-COMP,STD	1	1			
39152	39152-0019	WEIGHT-RAMP	4	4			
49048	49048-1087	SHOE,T=7.2	AR	AR			
49048A	49048-1088	SHOE,T=7.3	AR	AR			
49048B	49048-1089	SHOE,T=7.4	AR	AR			
49048C	49048-1090	SHOE,T=7.5	8	8			
49048D	49048-1091	SHOE,T=7.6	AR	AR			
49048E	49048-1092	SHOE,T=7.7	AR	AR			
49048F	49048-1093	SHOE,T=7.8	AR	AR			
49048G	49048-1094	SHOE,T=7.9	AR	AR			
49048H	49048-1095	SHOE,T=8.0	AR	AR			
49050	49050-0010	SPIDER	1	1			
49093	49093-0022	CONVERTER-ASSY-DRIVE	1	1			
59301	59301-0007	SHEAVE-MOVABLE	1	1			
59302	59302-0003	SHEAVE-COMP	1	1			
92019	92019-008	NUT,LOCK,6MM	8	8			
92026	92026-1603	SPACER,39X49.5X1.0	1	1			
92028	92028-1975	BUSHING	1	1			
92043	92043-1263	PIN,6.2X8X14	2	2			
92043A	92043-1688	PIN	4	4			
92139	92139-0215	BUSHING	4	4			
92145	92145-0557	SPRING	1	1			
92151	92151-1393	BOLT,12X165	1	1			
92200	92200-1504	WASHER,SPRING	2	2			
92200A	92200-1634	WASHER	1	1			
130	130CA0630	BOLT-FLANGED,6X30	8	8			

This catalog covers:

'08~'09 KVF750 D8F/D9F Engine

GRID NO.

B-13

This grid covers:

Driven Converter/Drive Belt

E1392

Ref. No.	Part No.	Description	Spec Code	Quantity-KVF750			
				'08	'09		
				D8F	D9F		
16007	16007-1203	SEAT-SPRING	1	1			
16007A	16007-1221	SEAT-SPRING,SHEAVE MOVABLE	1	1			
49074	49074-1055	PLATE-THRUST	1	1			
49094	49094-0019	CONVERTER-ASSY-DRIVEN	1	1			
59011	59011-0003	BELT	1	1			
59302	59302-0001	SHEAVE-COMP,FIXED	1	1			
59302A	59302-0002	SHEAVE-COMP,MOVABLE	1	1			
92026	92026-0034	SPACER,T=0.30	AR	AR			
92026A	92026-1565	SPACER,T=1.00	AR	AR			
92026B	92026-1569	SPACER,T=0.60	AR	AR			
92026C	92026-1570	SPACER,T=1.40	AR	AR			
92026D	92026-1617	SPACER,T=0.80	AR	AR			
92033	92033-1317	RING-SNAP	1	1			
92049	92049-1528	SEAL-OIL	2	2			
92122	92122-1209	ROLLER	4	4			
92145	92145-1499	SPRING,PURPLE	1	1			
92200	92200-1505	WASHER	2	2			
92210	92210-1367	NUT,18MM	1	1			
671	671D2530	O RING	1	1			
671A	671D2550	O RING	1	1			

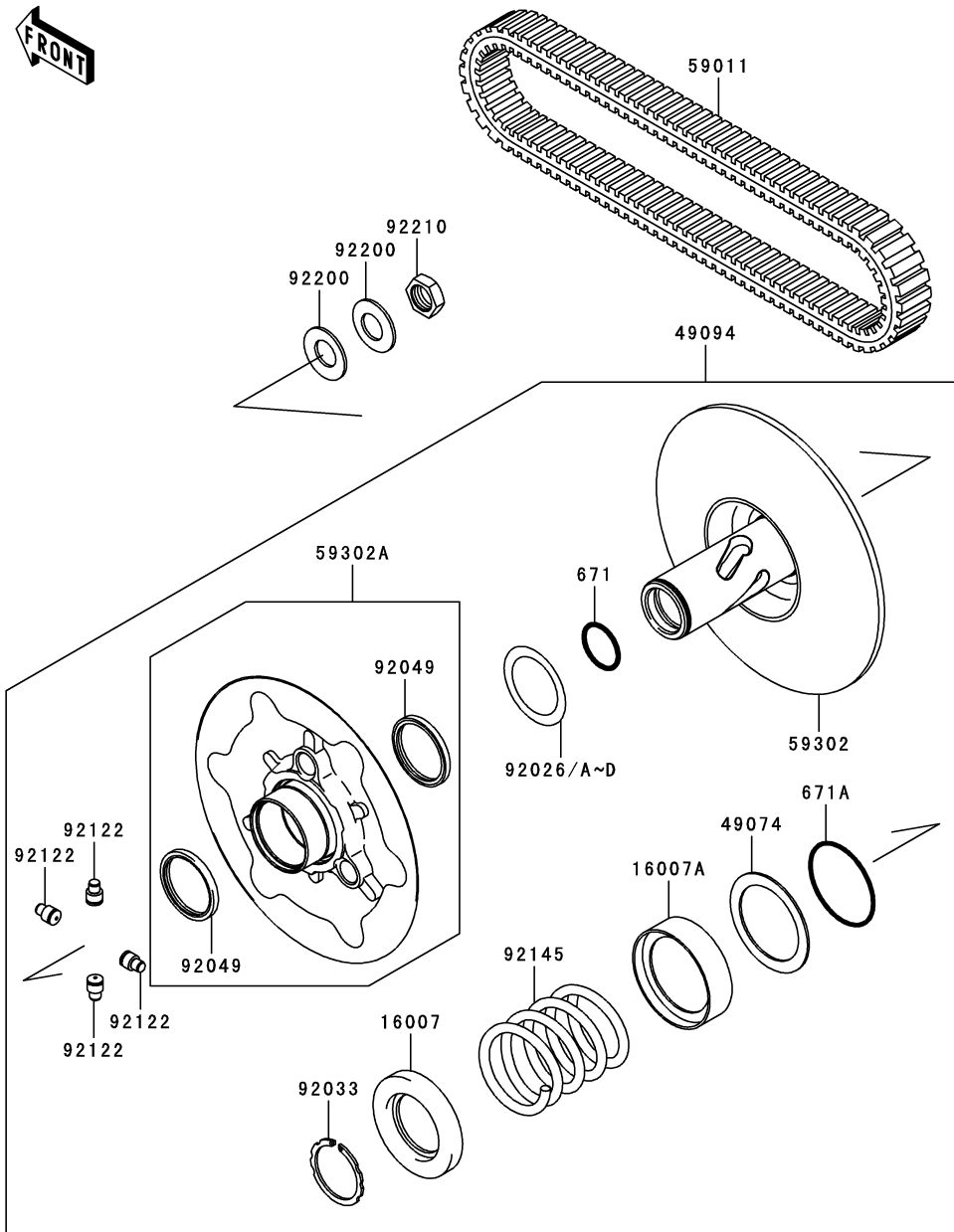

This catalog covers:

'08~'09 KVF750 D8F/D9F Engine

GRID NO.

B-14

This grid covers:

Converter Cover

E1393

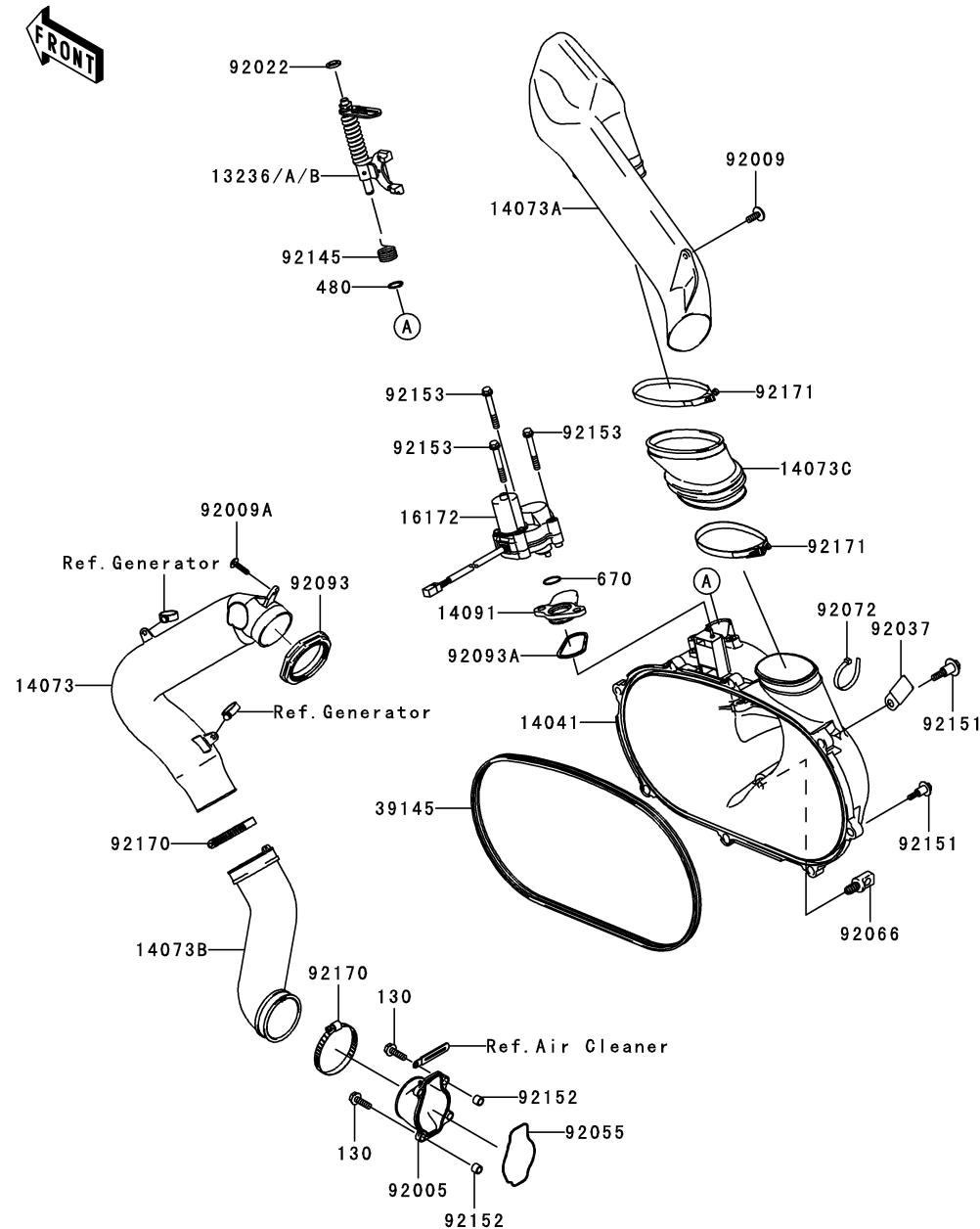

Ref. No.	Part No.	Description	Spec Code	Quantity-KVF750			
				'08	'09		
				D8F	D9F		
13236	13236-0046	LEVER-COMP,YELLOW	AR	AR			
13236A	13236-0047	LEVER-COMP,GREEN	AR	AR			
13236B	13236-0048	LEVER-COMP,PAINT LESS	1	1			
14041	14041-0004	COVER-COMP	1	1			
14073	14073-0025	DUCT,INTAKE	1	1			
14073A	14073-0026	DUCT,EXHAUST	1	1			
14073B	14073-0027	DUCT,INTAKE JOINT	1	1			
14073C	14073-0028	DUCT,EXHAUST JOINT	1	1			
14091	14091-1421	COVER	1	1			
16172	16172-0006	ACTUATOR	1	1			
39145	39145-1135	TRIM-SEAL	1	1			
92005	92005-1387	FITTING	1	1			
92009	92009-1694	SCREW,6X16	1	1			
92009A	92009-1993	SCREW,TAPPING,5X20	1	1			
92022	92022-1829	WASHER,10.2X16X1	1	1			
92037	92037-1780	CLAMP	1	1			
92055	92055-1630	RING-O	1	1			
92066	92066-1580	PLUG,DRAIN,11X19	1	1			
92072	92072-1239	BAND,L=188	1	1			
92093	92093-0016	SEAL	1	1			
92093A	92093-1548	SEAL	1	1			
92145	92145-1567	SPRING	1	1			
92151	92151-1686	BOLT,FLANGED,6X30	8	8			
92152	92152-1332	COLLAR	4	4			
92153	92153-0678	BOLT,6X47	3	3			
92170	92170-1764	CLAMP	2	2			
92171	92171-0208	CLAMP	2	2			
130	130CD0620	BOLT-FLANGED,6X20	4	4			
480	480J1000	CIRCLIP-TYPE-C,10MM	1	1			
670	670D3022	O RING	1	1			

This catalog covers:

'08~'09 KVF750 D8F/D9F Engine

GRID NO.

C-3

This grid covers:

Crankcase

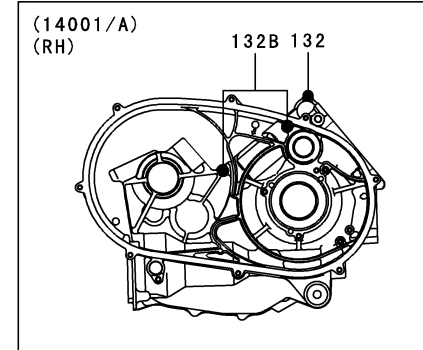
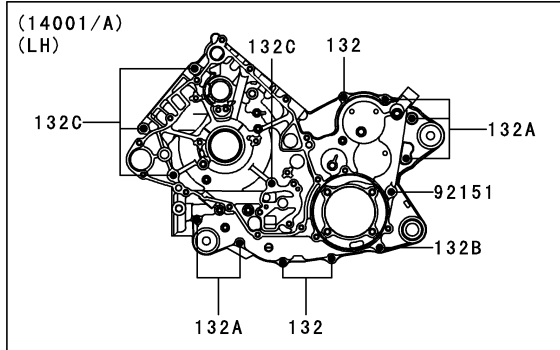
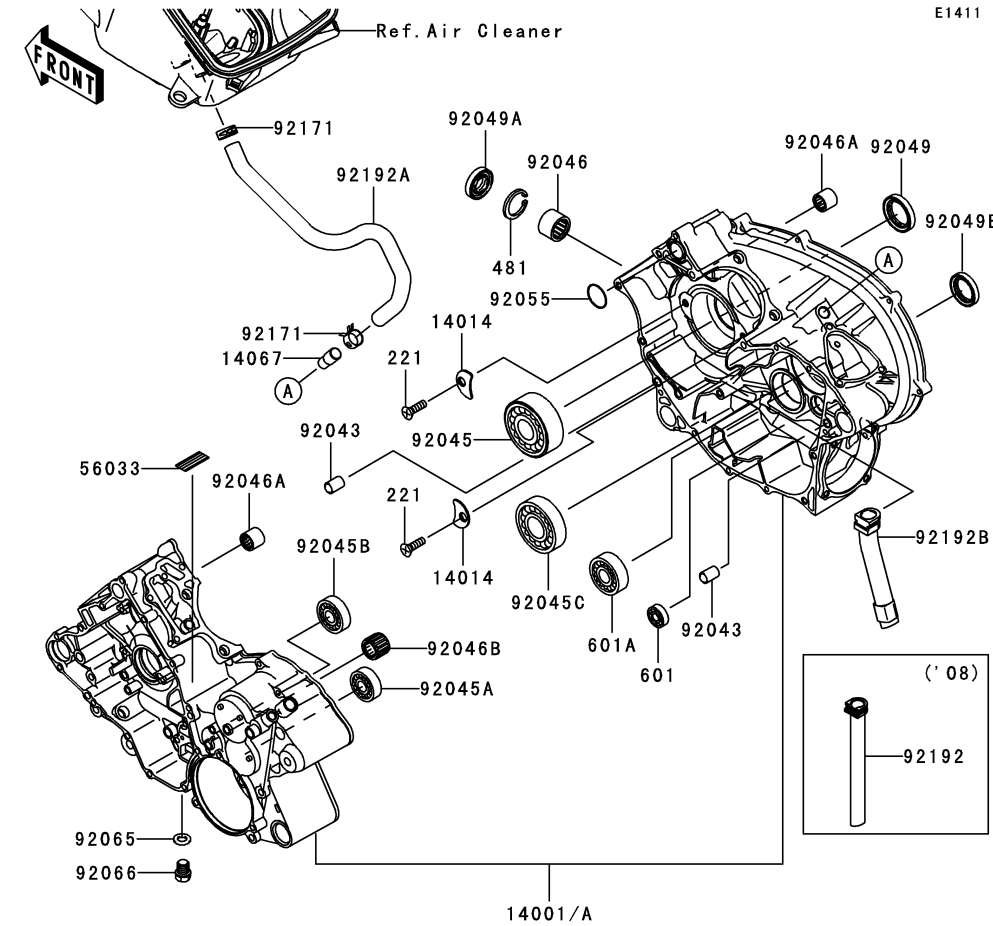

E1411

Ref. No.	Part No.	Description	Spec Code	Quantity-KVF750			
				'08	'09		
				D8F	D9F		
14001	14001-0015	SET-CRANKCASE		1			
14001A	14001-0109	SET-CRANKCASE			1		
14014	14014-0006	PLATE-POSITION		2	2		
14067	14067-006	FITTING,BREATHER		1	1		
56033	56033-0078	LABEL-MANUAL,OIL LEVEL		1	1		
92043	92043-1506	PIN,10X14		2	2		
92045	92045-0012	BEARING-BALL,5208X2-A-ECG45		1	1		
92045A	92045-0076	BEARING-BALL,#6004		1	1		
92045B	92045-0091	BEARING-BALL,6303LUA		1	1		
92045C	92045-1190	BEARING-BALL,6306SH2		1	1		
92046	92046-0022	BEARING-NEEDLE		1	1		
92046A	92046-1118	BEARING-NEEDLE,TA202715ZE		2	2		
92046B	92046-1143	BEARING-NEEDLE		1	1		
92049	92049-1452	SEAL-OIL,TC 35X50X8		1	1		
92049A	92049-1570	SEAL-OIL,TCY 28X42X8		1	1		
92049B	92049-1575	SEAL-OIL,HTC 30X45X8		1	1		
92055	92055-1136	RING-O,25.7X2.4		1	1		
92065	92065-097	GASKET,12X22X2		1	1		
92066	92066-1174	PLUG,OIL DRAIN,12X15		1	1		
92151	92151-1689	BOLT,8X110		1	1		
92171	92171-0329	CLAMP		2	2		
92192	92192-0057	TUBE,OIL RETURN		1			
92192A	92192-0436	TUBE,CRANKCASE-A/C		1	1		
92192B	92192-0560	TUBE,OIL RETURN			1		
132	132BD0640	BOLT-FLANGED-SMALL,6X40		4	4		
132A	132BD0665	BOLT-FLANGED-SMALL,6X65		5	5		
132B	132BD08110	BOLT-FLANGED-SMALL,8X110		3	3		
132C	132BD0875	BOLT-FLANGED-SMALL,8X75		4	4		
221	221AA0616	SCREW-CSK-CROS,6X16		2	2		
481	481J3700	CIRCLIP-TYPE-C,37MM		1	1		
601	601A6000	BEARING-BALL		1	1		
601A	601A6304	BEARING-BALL,#6304		1	1		

This catalog covers:

'08~'09 KVF750 D8F/D9F Engine

GRID NO.

C-4

This grid covers:

Engine Cover(s)

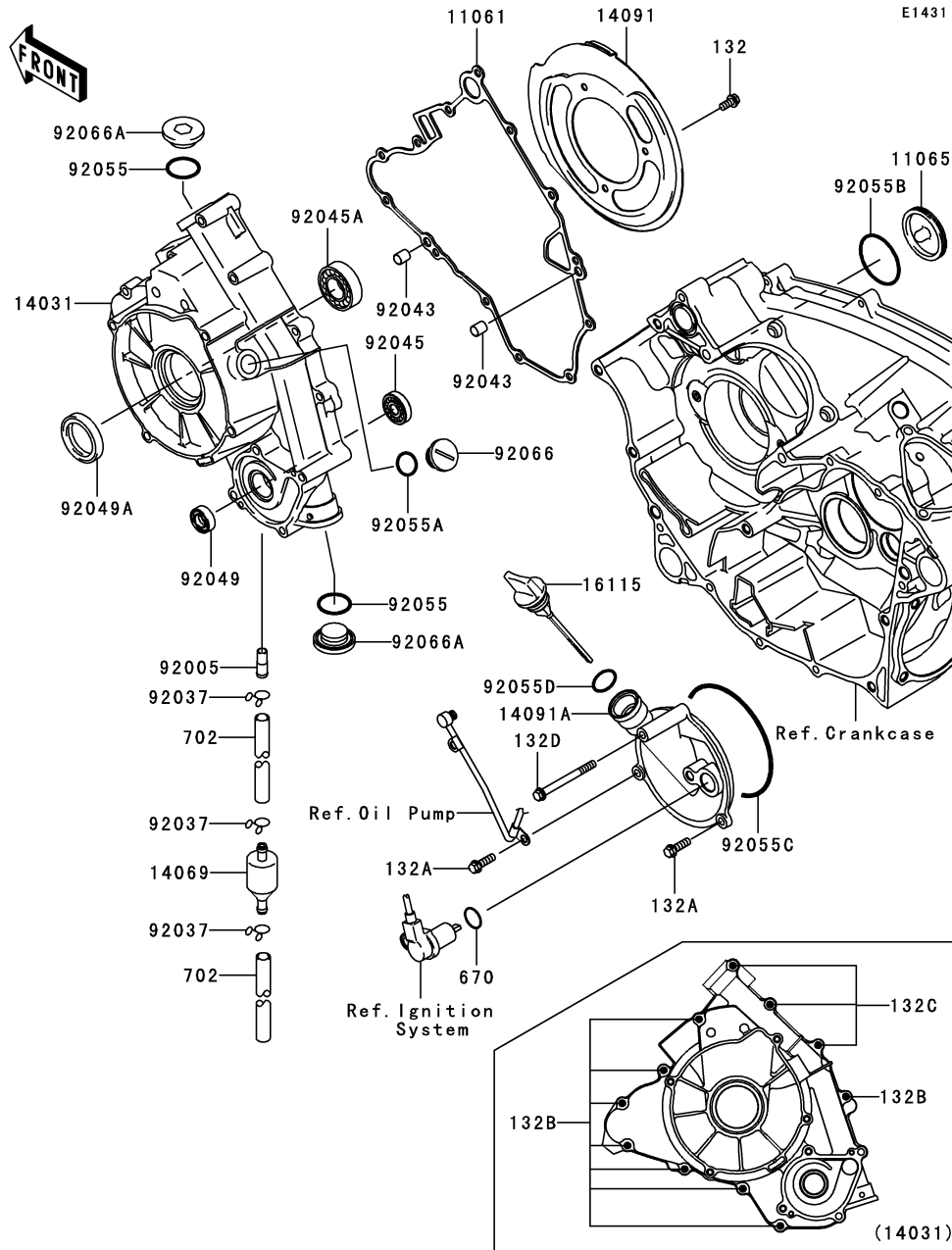

Ref. No.	Part No.	Description	Spec Code	Quantity-KVF750			
				'08	'09		
				D8F	D9F		
11061	11061-1119	GASKET	1	1			
11065	11065-1151	CAP	1	1			
14031	14031-0030	COVER-GENERATOR	1	1			
14069	14069-1051	BREATHER	1	1			
14091	14091-0309	COVER,BELT CONVERTER	1	1			
14091A	14091-1365	COVER	1	1			
16115	16115-1072	CAP-OIL FILLER	1	1			
92005	92005-1369	FITTING	1	1			
92037	92037-147	CLAMP,TUBE	3	3			
92043	92043-1263	PIN,6.2X8X14	2	2			
92045	92045-0084	BEARING-BALL,6901	1	1			
92045A	92045-0086	BEARING-BALL,TMB004JR2CM	1	1			
92049	92049-1228	SEAL-OIL,SC 12X22X5	1	1			
92049A	92049-1576	SEAL-OIL,HTC 28X45X7	1	1			
92055	92055-1136	RING-O,25.7X2.4	2	2			
92055A	92055-1146	RING-O,20X2	1	1			
92055B	92055-1279	RING-O,44.7X2.4	1	1			
92055C	92055-1632	RING-O,99.5X2.0	1	1			
92055D	92055-2185	RING-O,20X3	1	1			
92066	92066-0011	PLUG,COVER	1	1			
92066A	92066-0012	PLUG,25X8	2	2			
132	132BD0612	BOLT-FLANGED-SMALL,6X12	3	3			
132A	132BD0620	BOLT-FLANGED-SMALL,6X20	2	2			
132B	132BD0630	BOLT-FLANGED-SMALL,6X30	8	8			
132C	132BD0655	BOLT-FLANGED-SMALL,6X55	3	3			
132D	132BD0665	BOLT-FLANGED-SMALL,6X65	1	1			
670	670D2018	O RING	1	1			
702	702A07035	TUBE-RUBBER,7X10X35	2	2			

This catalog covers:

'08~'09 KVF750 D8F/D9F Engine

GRID NO.

C-5

This grid covers:

Throttle

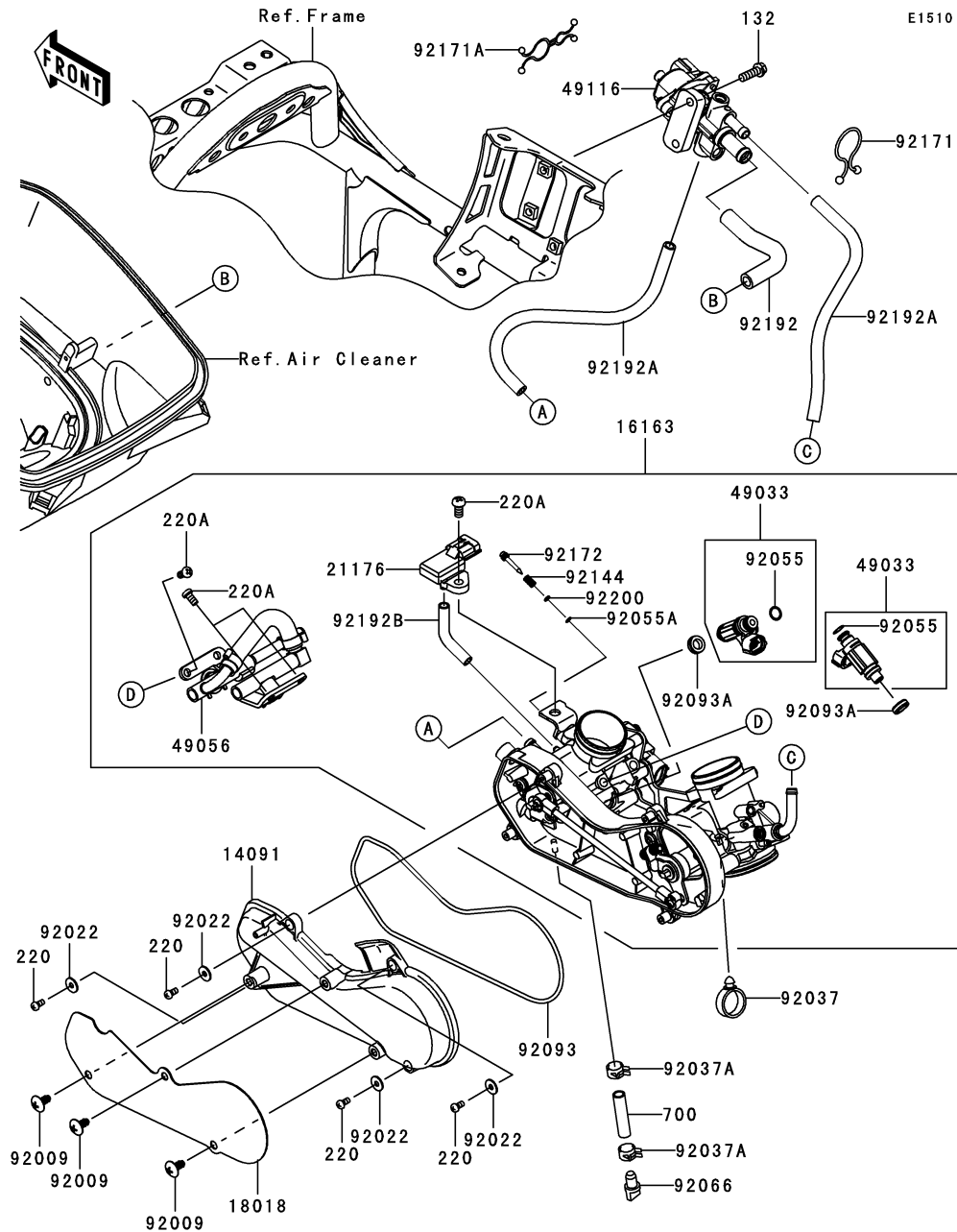

Ref. No.	Part No.	Description	Spec Code	Quantity-KVF750			
				'08	'09		
				D8F	D9F		
14091	14091-0737	COVER		1	1		
16163	16163-0125	THROTTLE-ASSY,36EIS		1	1		
18018	18018-0010	PLATE-HEAT GUARD		1	1		
21176	21176-0058	SENSOR,PRESSURE		1	1		
49033	49033-1060	NOZZLE-INJECTION		2	2		
49056	49056-0021	PIPE-INJECTION		1	1		
49116	49116-0021	VALVE-ASSY		1	1		
92009	92009-1480	SCREW,6X12		3	3		
92022	92022-1380	WASHER,5.2X13X1		4	4		
92037	92037-1827	CLAMP,HOSE		1	1		
92037A	92037-2113	CLAMP		2	2		
92055	92055-1622	RING-O,INJECTION NOZZLE		2	2		
92055A	92055-1658	RING-O,AIR SCREW		2	2		
92066	92066-1211	PLUG,DRAIN		1	1		
92093	92093-0082	SEAL		1	1		
92093A	92093-0127	SEAL		2	2		
92144	92144-1674	SPRING,THROTTLE STOP SCREW		2	2		
92171	92171-1185	CLAMP		1	1		
92171A	92171-1438	CLAMP		1	1		
92172	92172-0156	SCREW		2	2		
92192	92192-0437	TUBE		1	1		
92192A	92192-0439	TUBE		2	2		
92192B	92192-0578	TUBE,3.2X7.4X50		1	1		
92200	92200-1564	WASHER,PILOT AIR SCREW		2	2		
132	132BD0618	BOLT-FLANGED-SMALL,6X18		2	2		
220	220AA0408	SCREW-PAN-CROSS,4X8		4	4		
220A	220AA0612	SCREW-PAN-CROSS,6X12		5	5		
700	700Q0740	TUBE-PVC		1	1		

This catalog covers:

'08~'09 KVF750 D8F/D9F Engine

GRID NO.

C-6

This grid covers:

Fuel Pump

E1520

Ref. No.	Part No.	Description	Spec Code	Quantity-KVF750			
				'08	'09		
				D8F	D9F		
13271	13271-0980	PLATE	1	1			
49040	49040-0033	PUMP-FUEL	1	1			
51044	51044-0041	TUBE-ASSY	1	1			
92151	92151-1754	BOLT,FLANGED,5X11.5	6	6			
670	670E5090	O RING	1	1			

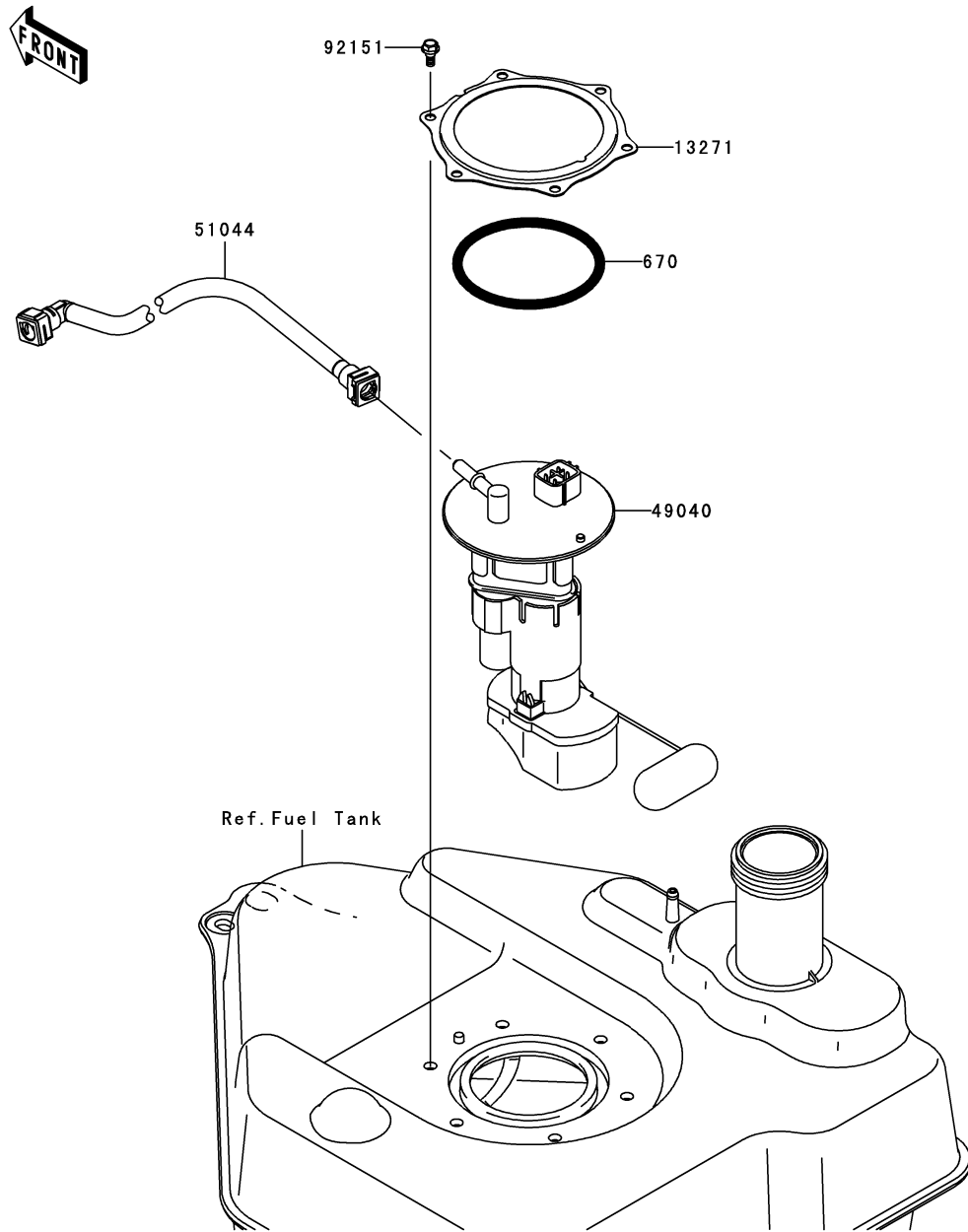

This catalog covers:

'08~'09 KVF750 D8F/D9F Engine

GRID NO.

C-7

This grid covers:

Fuel Injection

E1530

Ref. No.	Part No.	Description	Spec Code	Quantity-KVF750			
				'08	'09		
				D8F	D9F		
21175	21175-0137	CONTROL UNIT-ELECTRONIC	1	1			
21176	21176-0009	SENSOR,WATER TEMP	1	1			
21176A	21176-0048	SENSOR,AIR TEMPERATURE	1	1			
21176B	21176-0066	SENSOR,VEHICLE-DOWN	1	1			
27002	27002-1062	RELAY-ASSY	2	2			
92009	92009-1984	SCREW,TAPPING,5X16	1	1			
92055	92055-0016	RING-O,9.5X1.9	1	1			
92161	92161-0465	DAMPER	1	1			

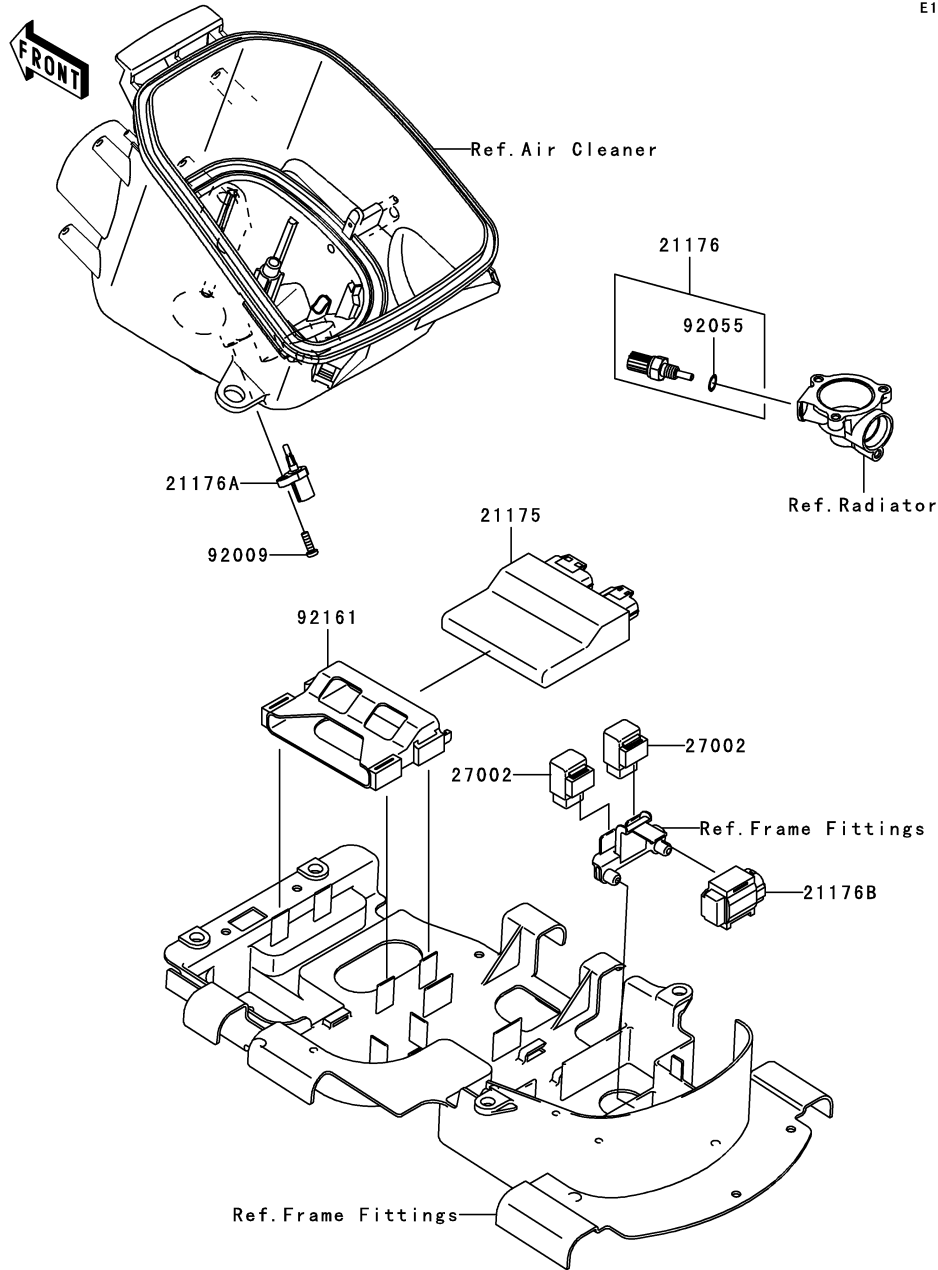

This catalog covers:

'08~'09 KVF750 D8F/D9F Engine

GRID NO.

C-8

This grid covers:

Oil Pump

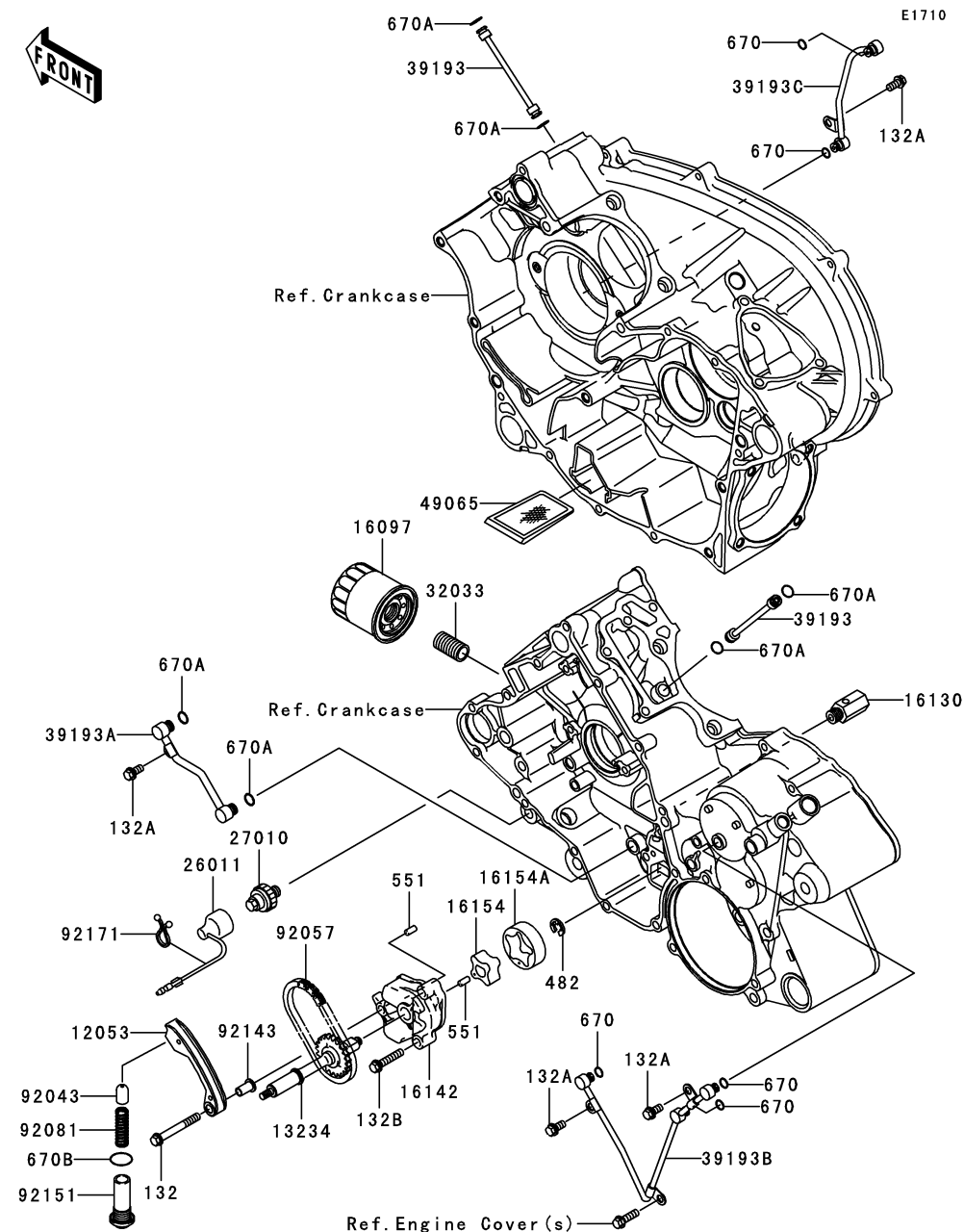

Ref. No.	Part No.	Description	Spec Code	Quantity-KVF750			
				'08	'09		
				D8F	D9F		
12053	12053-1440	GUIDE-CHAIN,SLACK	1	1			
13234	13234-1112	SHAFT-COMP,OIL PUMP	1	1			
16097	16097-0003	FILTER-ASSY-OIL	1	1			
16130	16130-1058	VALVE-ASSY-RELIEF	1	1			
16142	16142-1162	COVER-PUMP	1	1			
16154	16154-2059	ROTOR-PUMP,INNER	1	1			
16154A	16154-2060	ROTOR-PUMP,OUTER	1	1			
26011	26011-1755	WIRE-LEAD	1	1			
27010	27010-1313	SWITCH,OIL PRESSURE	1	1			
32033	32033-1535	PIPE,OIL FILTER	1	1			
39193	39193-0015	PIPE-OIL,CRANKCASE-HEAD	2	2			
39193A	39193-1052	PIPE-OIL,CRANKSHAFT	1	1			
39193B	39193-1053	PIPE-OIL,CRANKCASE,LH	1	1			
39193C	39193-1054	PIPE-OIL,CRANKCASE,RH	1	1			
49065	49065-1086	FILTER-OIL	1	1			
92043	92043-076	PIN	1	1			
92057	92057-0075	CHAIN,DID SCR-0409 SDH	1	1			
92081	92081-112	SPRING	1	1			
92143	92143-1857	COLLAR	1	1			
92151	92151-1781	BOLT,16X41	1	1			
92171	92171-1329	CLAMP	1	1			
132	132BB0650	BOLT-FLANGED-SMALL,6X50	1	1			
132A	132BD0612	BOLT-FLANGED-SMALL,6X12	4	4			
132B	132BD0630	BOLT-FLANGED-SMALL,6X30	2	2			
482	482J6000	CIRCLIP-TYPE-E,6MM	1	1			
551	551A0408	PIN-DOWEL,4X8	2	2			
670	670D1505	O RING	5	5			
670A	670D1507	O RING,7MM	6	6			
670B	670D2016	O RING,16MM	1	1			

This catalog covers:

'08~'09 KVF750 D8F/D9F Engine

GRID NO.

C-9

This grid covers:

Generator

E1810

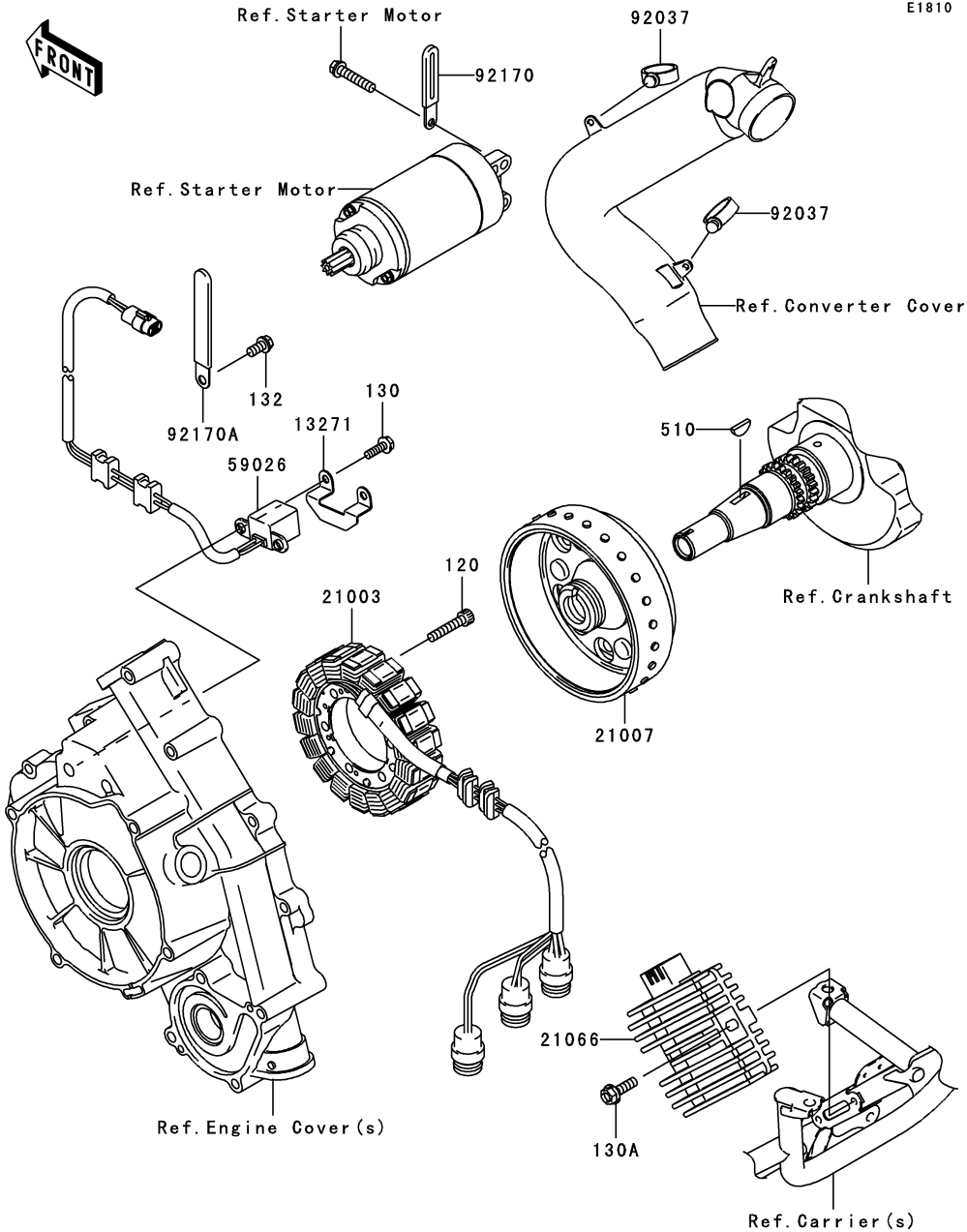

Ref. No.	Part No.	Description	Quantity-KVF750			
			Spec Code		'08	'09
			D8F	D9F		
13271	13271-1369	PLATE			1	1
21003	21003-0071	STATOR			1	1
21007	21007-0111	ROTOR			1	1
21066	21066-0030	REGULATOR-VOLTAGE			1	1
59026	59026-0005	COIL-PULSING			1	1
92037	92037-1827	CLAMP,HOSE			2	2
92170	92170-1514	CLAMP			1	1
92170A	92170-1925	CLAMP			1	1
120	120CB0630	BOLT-SOCKET,6X30			3	3
130	130BA0516	BOLT-FLANGED,5X16			2	2
130A	130BB0620	BOLT-FLANGED,6X20			2	2
132	132BD0612	BOLT-FLANGED-SMALL,6X12			1	1
510	510A4200	KEY-WOODRUFF			1	1

This catalog covers:

'08~'09 KVF750 D8F/D9F Engine

GRID NO.

C-10

This grid covers:

Ignition System

E1830

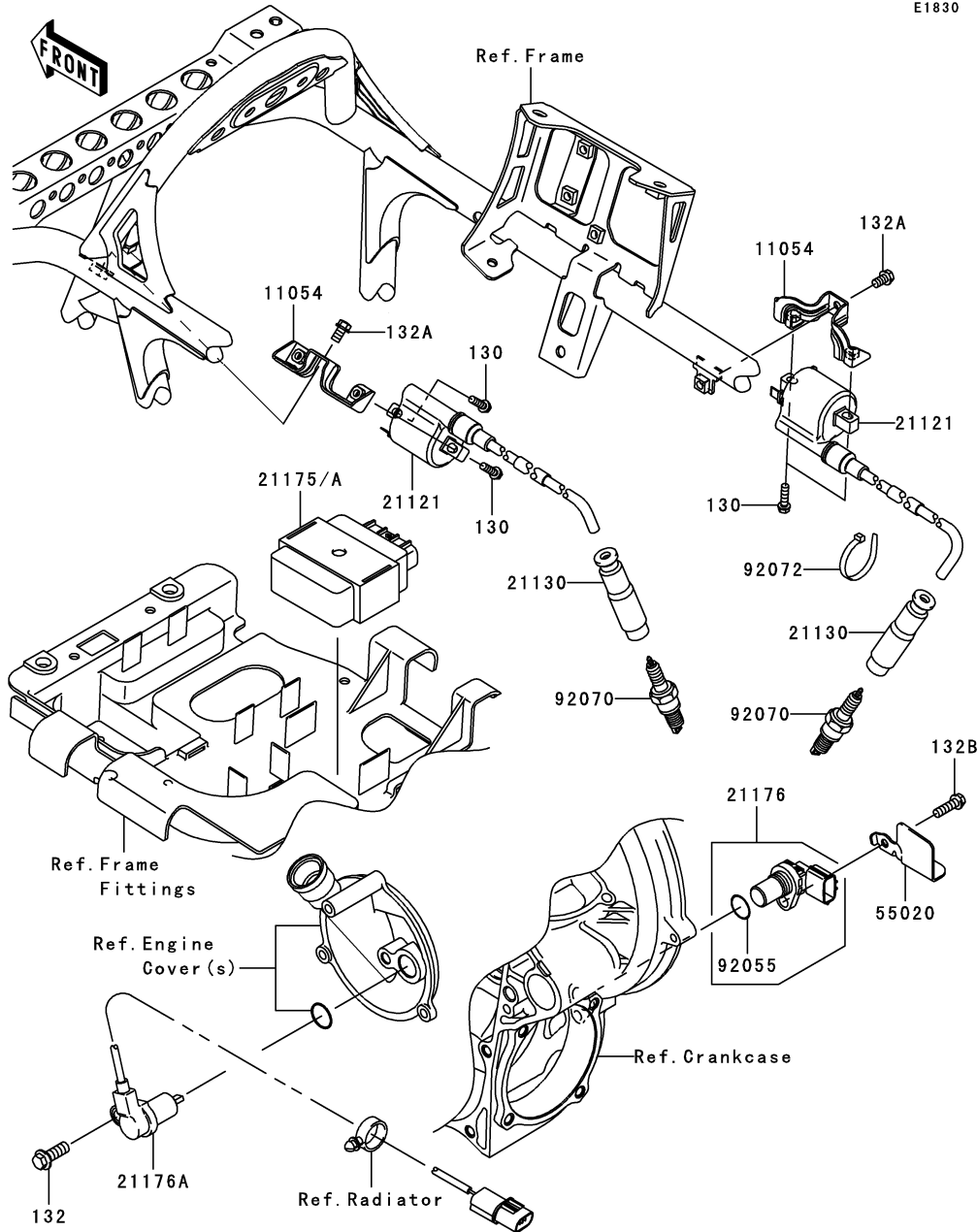

Ref. No.	Part No.	Description	Quantity-KVF750			
			Spec Code		'08	'09
			D8F	D9F		
11054	11054-1328	BRACKET			2	2
21121	21121-0039	COIL-IGNITION			2	2
21130	21130-1071	CAP-SPARK PLUG			2	2
21175	21175-0086	CONTROL UNIT-ELECTRONIC			1	
21175A	21175-0216	CONTROL UNIT-ELECTRONIC				1
21176	21176-1104	SENSOR,SPEED			1	1
21176A	21176-1109	SENSOR,REVERSE			1	1
55020	55020-0247	GUARD			1	1
92055	92055-1718	RING-O			1	1
92070	92070-1209	PLUG-SPARK,CR7E(NGK)			2	2
92072	92072-1239	BAND,L=188			1	1
130	130BB0518	BOLT-FLANGED,5X18			4	4
132	132BA0822	BOLT-FLANGED-SMALL,8X22			1	1
132A	132BD0610	BOLT-FLANGED-SMALL,6X10			2	2
132B	132BD0620	BOLT-FLANGED-SMALL,6X20			1	1

This catalog covers:

'08~'09 KVF750 D8F/D9F Engine

GRID NO.

C-11

This grid covers:

Starter Motor

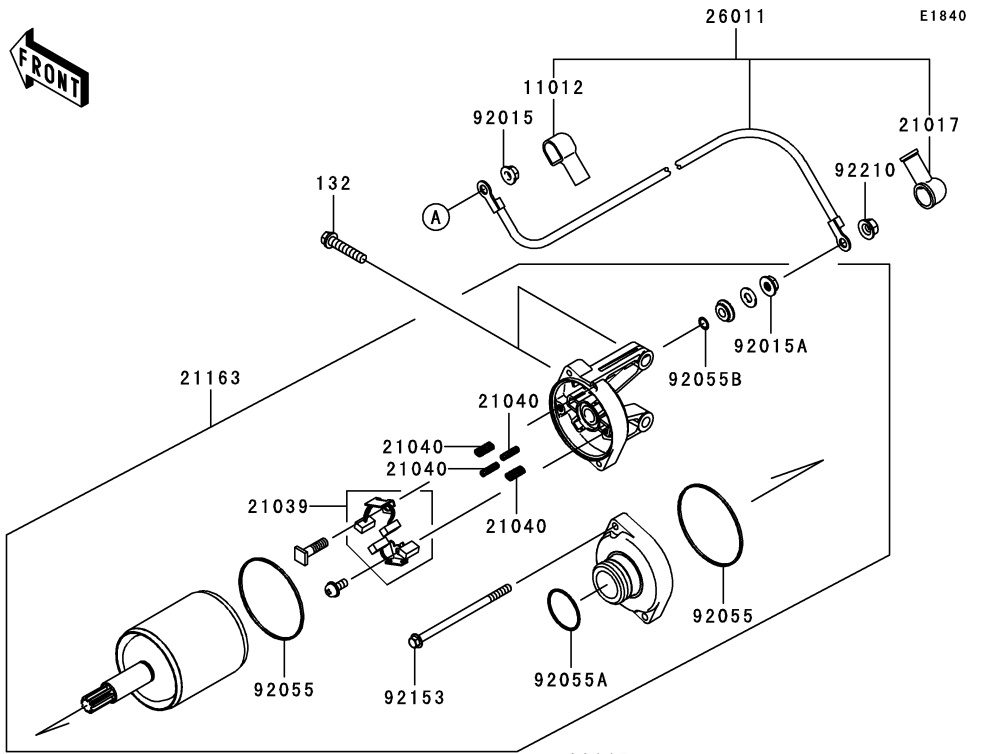

Ref. No.	Part No.	Description	Spec Code	Quantity-KVF750			
				'08	'09		
				D8F	D9F		
11012	11012-1354	CAP,TERMINAL	1	1			
13194	13194-1094	CLUTCH-ONEWAY	1	1			
16085	16085-1238	GEAR,STARTER	1	1			
21017	21017-017	GROMMET,STARTER TERMINAL	1	1			
21039	21039-0004	BRUSH,CARBON	1	1			
21040	21040-0003	SPRING-BRUSH	4	4			
21064	21064-002	DAMPER,MAGNETIC SWITCH	1	1			
21163	21163-0037	STARTER-ELECTRIC	1	1			
26011	26011-0111	WIRE-LEAD,STARTER CABLE	1	1			
27010	27010-1098	SWITCH,MAGNETIC	1	1			
39076	39076-0005	LIMITER,STARTER	1	1			
92015	92015-1193	NUT,FLANGED,6MM	2	2			
92015A	92015-1476	NUT,STARTER MOTOR	1	1			
92048	92048-0002	RACE,ONE WAY CLUTCH	1	1			
92055	92055-0136	RING-O	2	2			
92055A	92055-1276	RING-O	1	1			
92055B	92055-1370	RING-O,4.5X2.0	1	1			
92153	92153-1850	BOLT	2	2			
92210	92210-0188	NUT,6MM	1	1			
120	120CA0816	BOLT-SOCKET,8X16	6	6			
132	132BD0630	BOLT-FLANGED-SMALL,6X30	2	2			

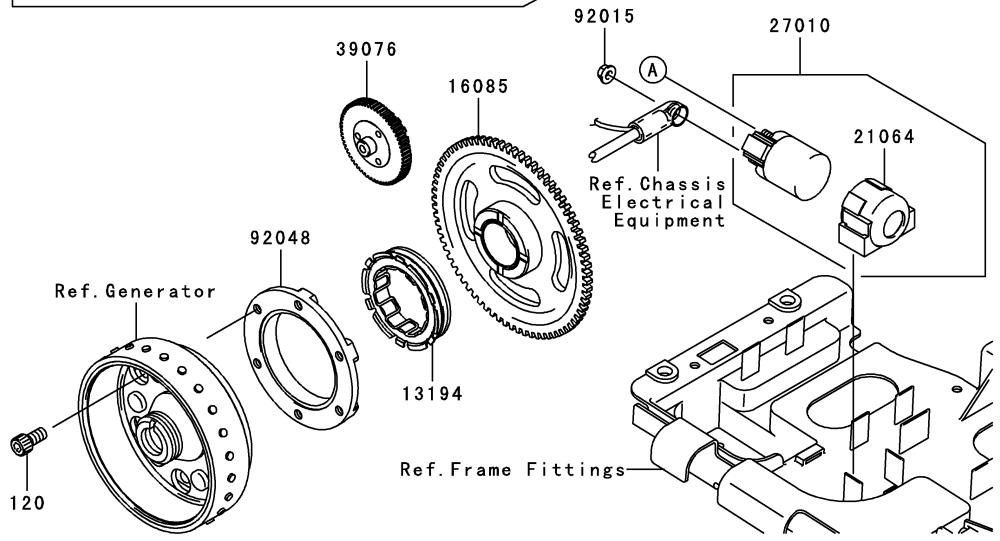

This catalog covers:

'08~'09 KVF750 D8F/D9F Engine

GRID NO.

C-12

This grid covers:

Radiator(1/2)

E3032

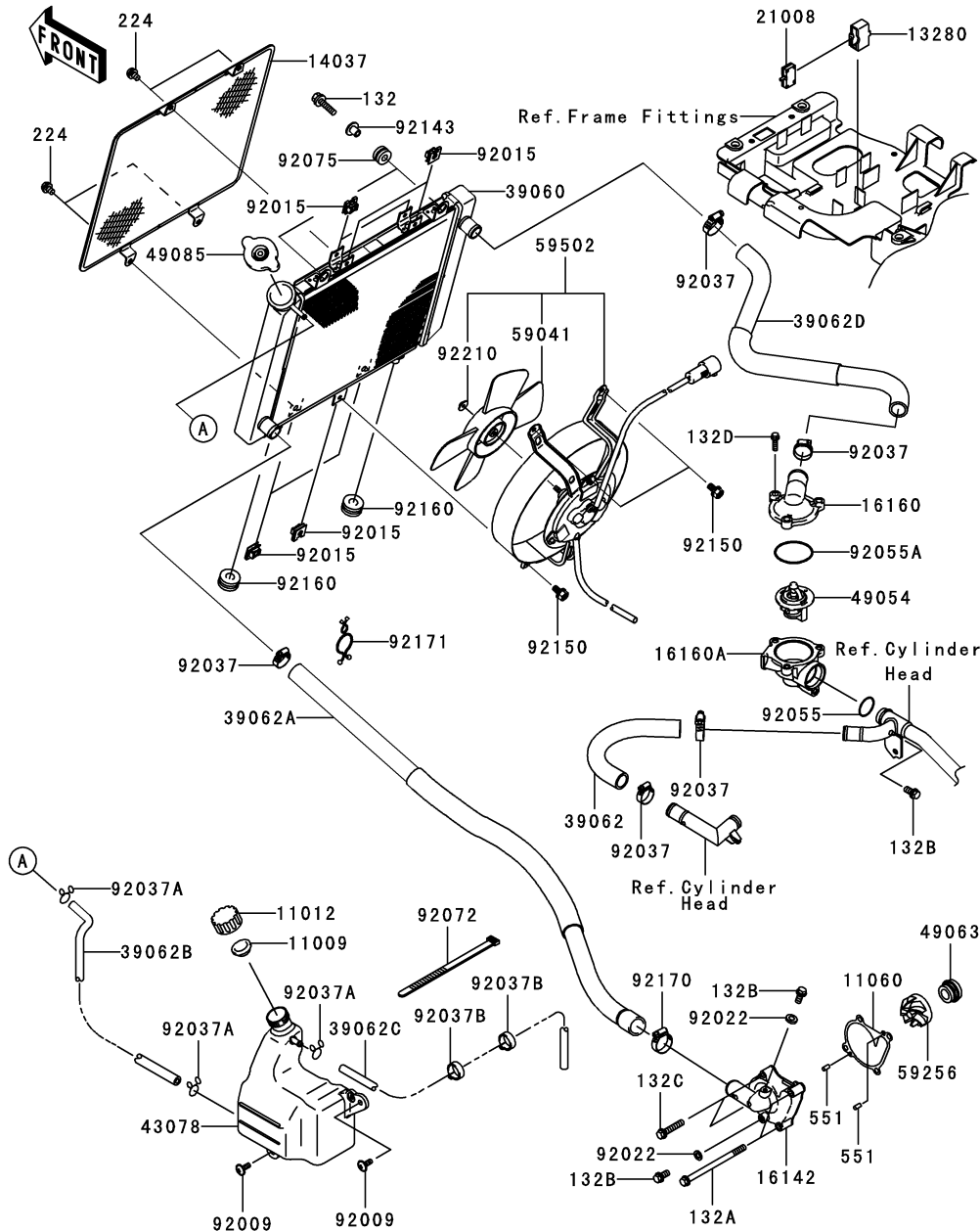

Ref. No.	Part No.	Description	Spec Code	Quantity-KVF750			
				'08	'09		
				D8F	D9F		
11009	11009-1145	GASKET,RESERVOIR TANK CAP	1	1			
11012	11012-1084	CAP	1	1			
11060	11060-1964	GASKET,WATER PUMP	1	1			
13280	13280-0082	HOLDER,BREAKER	1	1			
14037	14037-0045	SCREEN	1	1			
16142	16142-0002	COVER-PUMP,WATER	1	1			
16160	16160-0046	BODY,THERMOSTAT,UPP	1	1			
16160A	16160-0127	BODY	1	1			
21008	21008-0001	BREAKER,FAN MOTOR	1	1			
39060	39060-0040	RADIATOR	1	1			
39062	39062-0178	HOSE-COOLING,FR HEAD-THERMO	1	1			
39062A	39062-0180	HOSE-COOLING,RAD-WATER PUMP	1	1			
39062B	39062-0226	HOSE-COOLING	1	1			
39062C	39062-0227	HOSE-COOLING	1	1			
39062D	39062-0241	HOSE-COOLING,THERMO-RADIATOR	1	1			
43078	43078-0024	RESERVOIR	1	1			
49054	49054-1055	THERMOSTAT	1	1			
49063	49063-1055	SEAL-MECHANICAL,WATER	1	1			
49085	49085-1066	CAP-ASSY-PRESSURE	1	1			
59041	59041-0002	FAN	1	1			
59256	59256-1069	IMPELLER	1	1			
59502	59502-0011	FAN-ASSY	1	1			
92009	92009-1694	SCREW,6X16	2	2			
92015	92015-1487	NUT	7	7			
92022	92022-304	WASHER,6.2X11X1	2	2			
92037	92037-1589	CLAMP,COOLING HOSE	5	5			
92037A	92037-1712	CLAMP	3	3			
92037B	92037-1827	CLAMP,HOSE	2	2			
92055	92055-1081	RING-O,22.1X2.4	1	1			
92055A	92055-1279	RING-O,44.7X2.4	1	1			
92072	92072-030	BAND,L=123	1	1			
92075	92075-209	DAMPER	2	2			
92143	92143-1353	COLLAR	2	2			
92150	92150-1186	BOLT,6X12	3	3			
92160	92160-1007	DAMPER	2	2			
92170	92170-1497	CLAMP	1	1			
92171	92171-1736	CLAMP	1	1			
92210	92210-0335	NUT	1	1			
132	132BA0625	BOLT-FLANGED-SMALL,6X25	2	2			
132A	132BB0690	BOLT-FLANGED-SMALL,6X90	2	2			

This catalog covers:

'08~'09 KVF750 D8F/D9F Engine

GRID NO.

C-13

This grid covers:

Radiator(2/2)

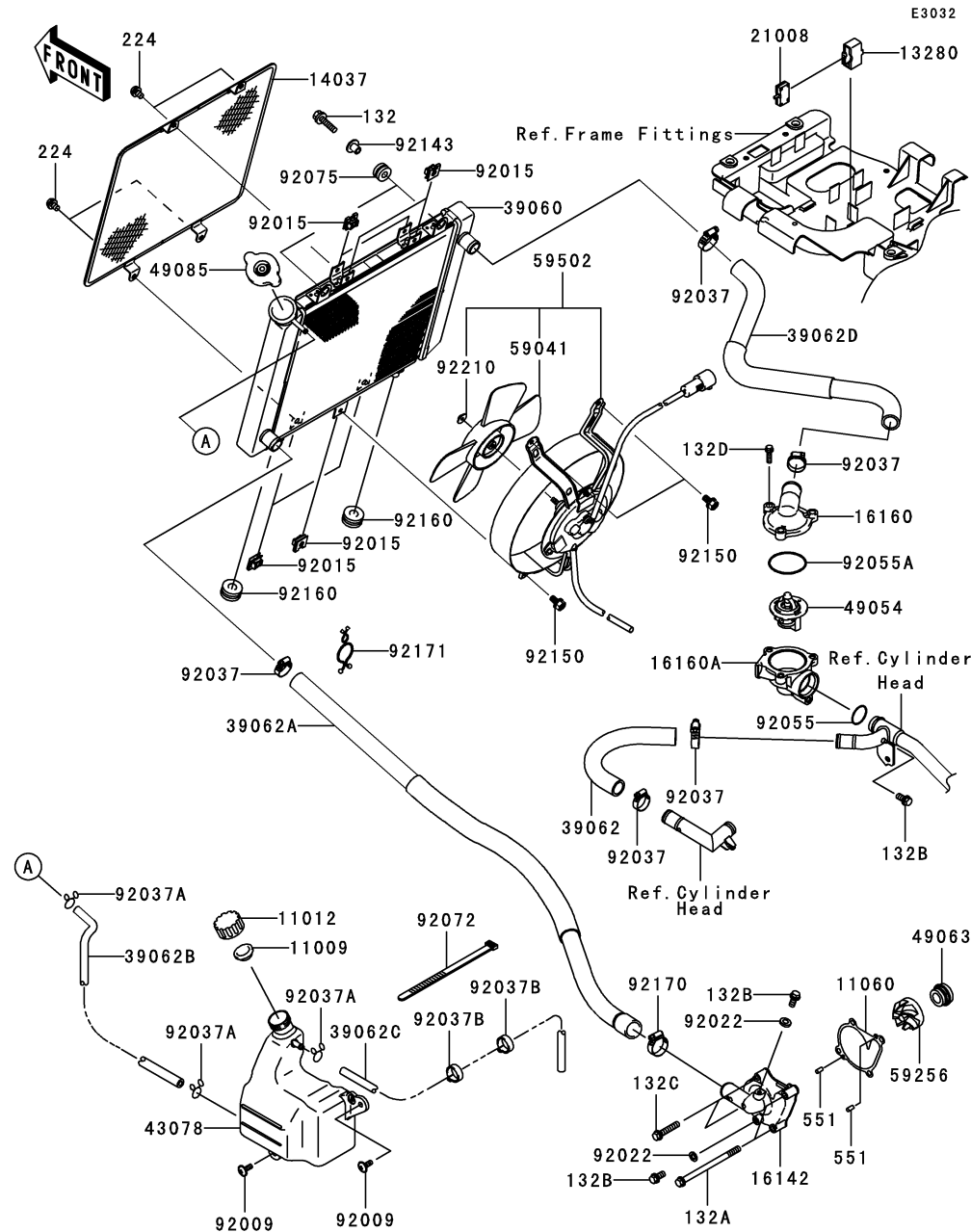

Ref. No.	Part No.	Description	Spec Code	Quantity-KVF750			
				'08	'09		
				D8F	D9F		
132B	132BD0612	BOLT-FLANGED-SMALL,6X12	3	3			
132C	132BD0630	BOLT-FLANGED-SMALL,6X30	2	2			
132D	132E0620	BOLT-FLANGED-SMALL,6X20	3	3			
224	224AB0610	SCREW-PAN-WP-CROS,6X10	4	4			
551	551A0408	PIN-DOWEL,4X8	2	2			

This catalog covers:

'08~'09 KVF750 D8F/D9F Engine

GRID NO.

C-14

This grid covers:

Recoil Starter

E3040

Ref. No.	Part No.	Description	Spec Code	Quantity-KVF750			
				'08	'09		
				D8F	D9F		
11061	11061-1153	GASKET	1	1			
14091	14091-0738	COVER	1	1			
92055	92055-1215	RING-O,19.8X2.2	1	1			
92150	92150-1987	BOLT,12X65	1	1			
92152	92152-1467	COLLAR,20X51X17	1	1			
92153	92153-7007	BOLT,FLANGED,6X16	4	4			

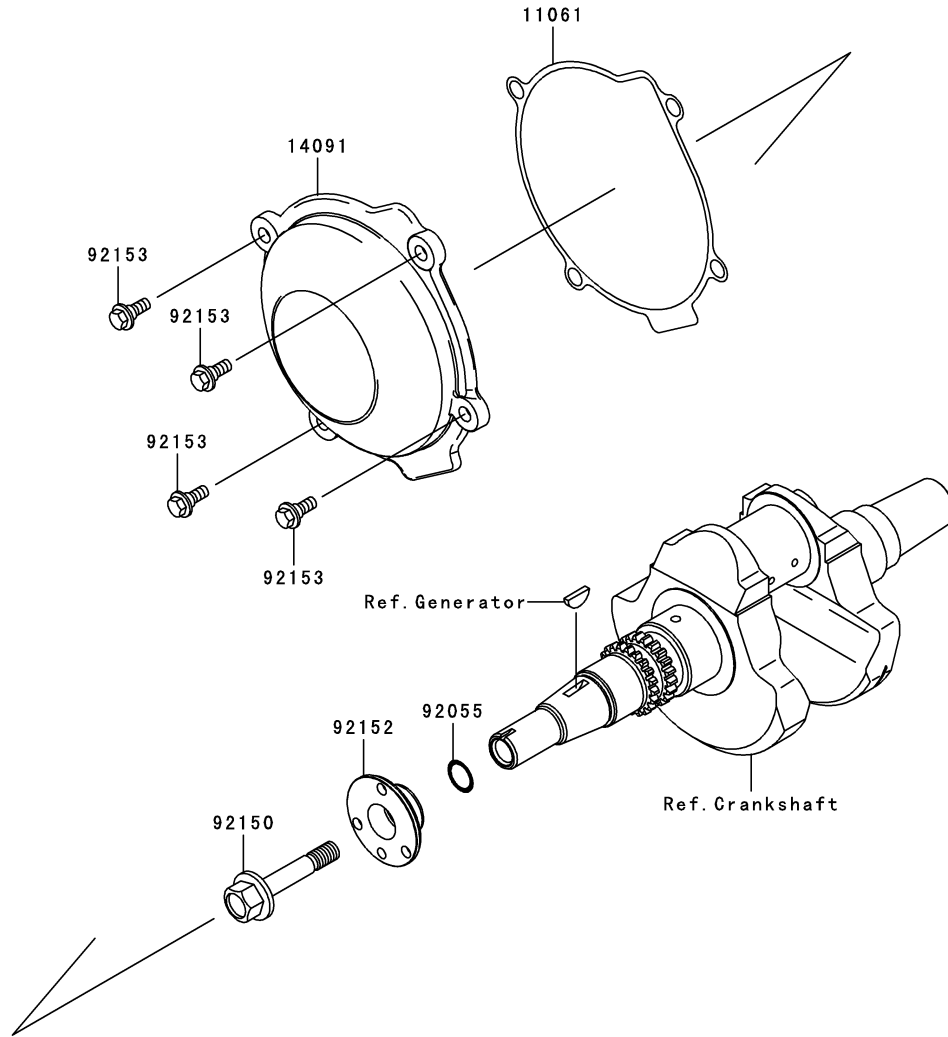

This catalog covers:

'08~'09 KVF750 D8F/D9F Engine

GRID NO.

D-3

This grid covers:

Front Bevel Gear

E3131

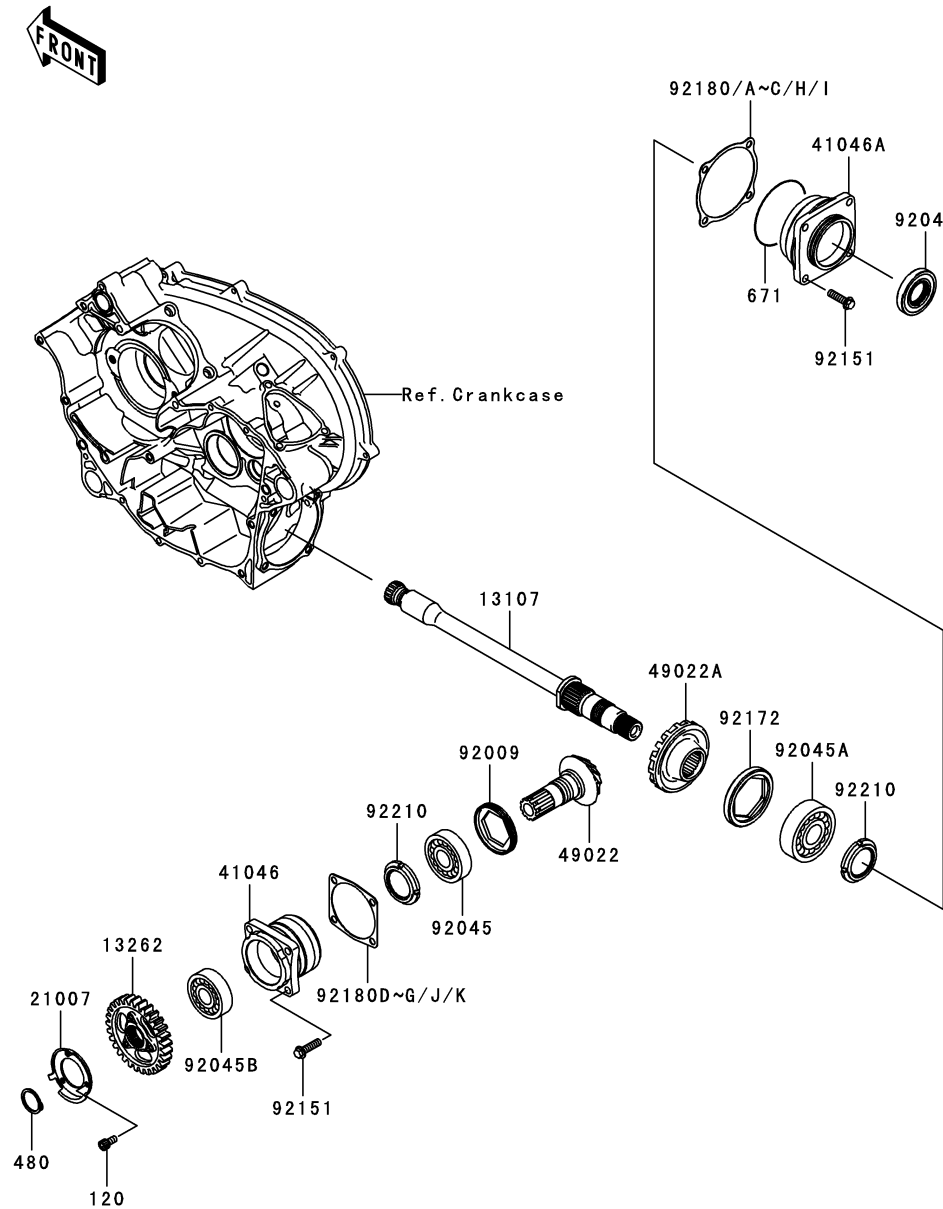

Ref. No.	Part No.	Description	Quantity-KVF750			
			'08	'09		
			D8F	D9F		
13107	13107-0114	SHAFT,F/R OUTPUT	1	1		
13262	13262-0494	GEAR,OUTPUT,29T	1	1		
21007	21007-1416	ROTOR,REVERSE SENSOR	1	1		
41046	41046-1101	HOUSING-BEARING	1	1		
41046A	41046-1102	HOUSING-BEARING	1	1		
49022	49022-0010	GEAR-BEVEL,DRIVE,12T	1	1		
49022A	49022-0011	GEAR-BEVEL,DRIVEN,20T	1	1		
92009	92009-1914	SCREW,64MM	1	1		
92045	92045-0110	BEARING-BALL,6206-9C3	1	1		
92045A	92045-1190	BEARING-BALL,6306SH2	1	1		
92045B	92045-1207	BEARING-BALL,62/28	1	1		
92049	92049-0095	SEAL-OIL	1	1		
92151	92151-1688	BOLT-FLANGED-SMALL,8X30	8	8		
92172	92172-0371	SCREW,SET,75X10	1	1		
92180	92180-1307	SHIM,DRIVEN,T=0.15	AR	AR		
92180A	92180-1308	SHIM,DRIVEN,T=0.20	AR	AR		
92180B	92180-1309	SHIM,DRIVEN,T=0.50	AR	AR		
92180C	92180-1310	SHIM,DRIVEN,T=0.80	AR	AR		
92180D	92180-1311	SHIM,DRIVE,T=0.15	AR	AR		
92180E	92180-1312	SHIM,DRIVE,T=0.20	AR	AR		
92180F	92180-1313	SHIM,DRIVE,T=0.50	AR	AR		
92180G	92180-1314	SHIM,DRIVE,T=0.80	AR	AR		
92180H	92180-1349	SHIM,DRIVEN,T=1.00	AR	AR		
92180I	92180-1350	SHIM,DRIVEN,T=1.20	AR	AR		
92180J	92180-1351	SHIM,DRIVE,T=1.00	AR	AR		
92180K	92180-1352	SHIM,DRIVE,T=1.20	AR	AR		
92210	92210-1294	NUT,30MM	2	2		
120	120CA0612	BOLT-SOCKET,6X12	3	3		
480	480J2800	CIRCLIP-TYPE-C,28MM	1	1		
671	671D2585	O RING	1	1		

This catalog covers:

'08~'09 KVF750 D8F/D9F Engine

GRID NO.

D-4

This grid covers:

Drive Shaft-Propeller

E3135

Ref. No.	Part No.	Description	Spec Code	Quantity-KVF750			
				'08	'09		
				D8F	D9F		
13107	13107-1505	SHAFT,FR PROPELLER SHAFT		1	1		
16007	16007-1205	SEAT-SPRING,PROPELLER SHAFT		1	1		
42034	42034-1193	COUPLING,PROPELLER		1	1		
49006	49006-1362	BOOT		3	3		
92055	92055-1633	RING-O,18X24X3		3	3		
92055A	92055-1693	RING-O,30X35X2.5		3	3		
92145	92145-1304	SPRING,PROPELLER SHAFT		1	1		
481	481J2500	CIRCLIP-TYPE-C,25MM		1	1		

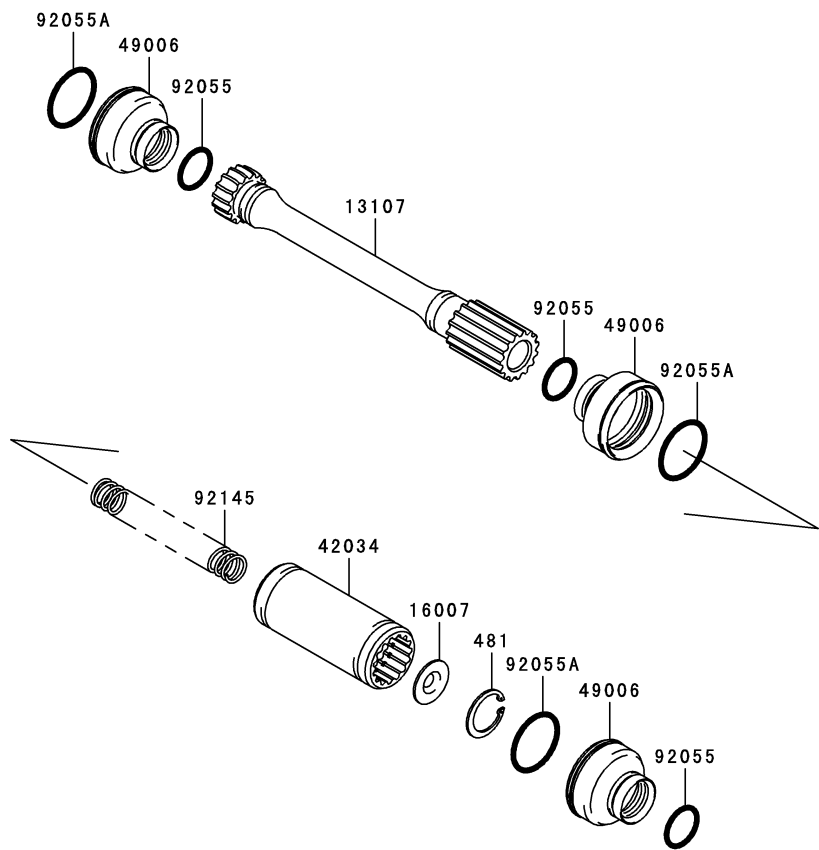

This catalog covers:

'08~'09 KVF750 D8F/D9F Engine

GRID NO.

D-5

This grid covers:

Drive Shaft-Front(1/3)

E3136

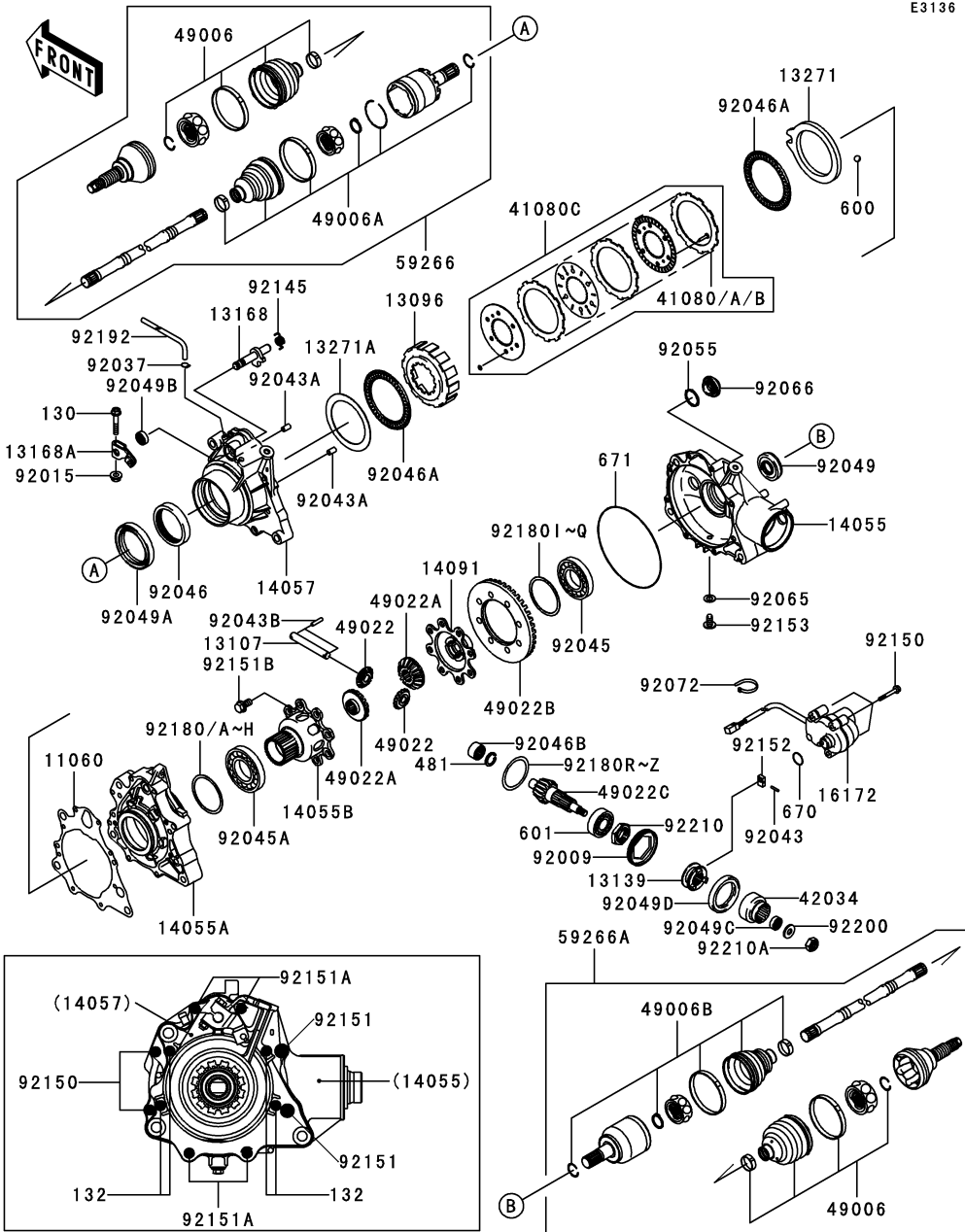

Ref. No.	Part No.	Description	Spec Code	Quantity-KVF750			
				'08	'09		
				D8F	D9F		
11060	11060-1982	GASKET,DIFF CASE	1	1			
13096	13096-1163	HOUSING-CLUTCH,DISC	1	1			
13107	13107-0123	SHAFT,CROSS	1	1			
13139	13139-1097	SHIFTER,DIFFERENTIAL	1	1			
13168	13168-1724	LEVER,DIFF	1	1			
13168A	13168-1725	LEVER,DIFFERENTIAL	1	1			
13271	13271-1497	PLATE,CAM	1	1			
13271A	13271-1503	PLATE,DISC	1	1			
14055	14055-0014	CASE-GEAR	1	1			
14055A	14055-1155	CASE-GEAR,CENTER	1	1			
14055B	14055-1156	CASE-GEAR,BEVEL,LH	1	1			
14057	14057-1004	CASE-COMP-GEAR,DIFF,LH	1	1			
14091	14091-1197	COVER,BEVEL,RH	1	1			
16172	16172-0007	ACTUATOR	1	1			
41080	41080-1499	DISC,T=1.20	AR	AR			
41080A	41080-1500	DISC,T=1.80	AR	AR			
41080B	41080-1501	DISC,T=2.40	AR	AR			
41080C	41080-1512	DISC ASSY,DIFFERENTIAL LOCK	1	1			
42034	42034-1192	COUPLING,BEVEL	1	1			
49006	49006-0062	BOOT	2	2			
	(OPTION)						
49006A	49006-0063	BOOT	1	1			
	(OPTION)						
49006B	49006-0068	BOOT	1	1			
	(OPTION)						
49022	49022-1177	GEAR-BEVEL,10T	2	2			
49022A	49022-1178	GEAR-BEVEL,16T	2	2			
49022B	49022-1190	GEAR-BEVEL,35T	1	1			
49022C	49022-1201	GEAR-BEVEL,8T	1	1			
59266	59266-0021	JOINT-BALL	1	1			
59266A	59266-0022	JOINT-BALL	1	1			
92009	92009-1914	SCREW,64MM	1	1			
92015	92015-1339	NUT,LOCK,FLANGED,6MM	1	1			
92037	92037-1104	CLAMPHOSE	1	1			
92043	92043-0083	PIN,2X10.5	1	1			
92043A	92043-1263	PIN,6.2X8X14	2	2			
92043B	92043-1575	PIN	2	2			
92045	92045-1393	BEARING-BALL,60/32	1	1			
92045A	92045-1394	BEARING-BALL,6910	1	1			
92046	92046-0028	BEARING-NEEDLE	1	1			

This catalog covers:

'08~'09 KVF750 D8F/D9F Engine

GRID NO.

D-6

This grid covers:

Drive Shaft-Front(2/3)

E3136

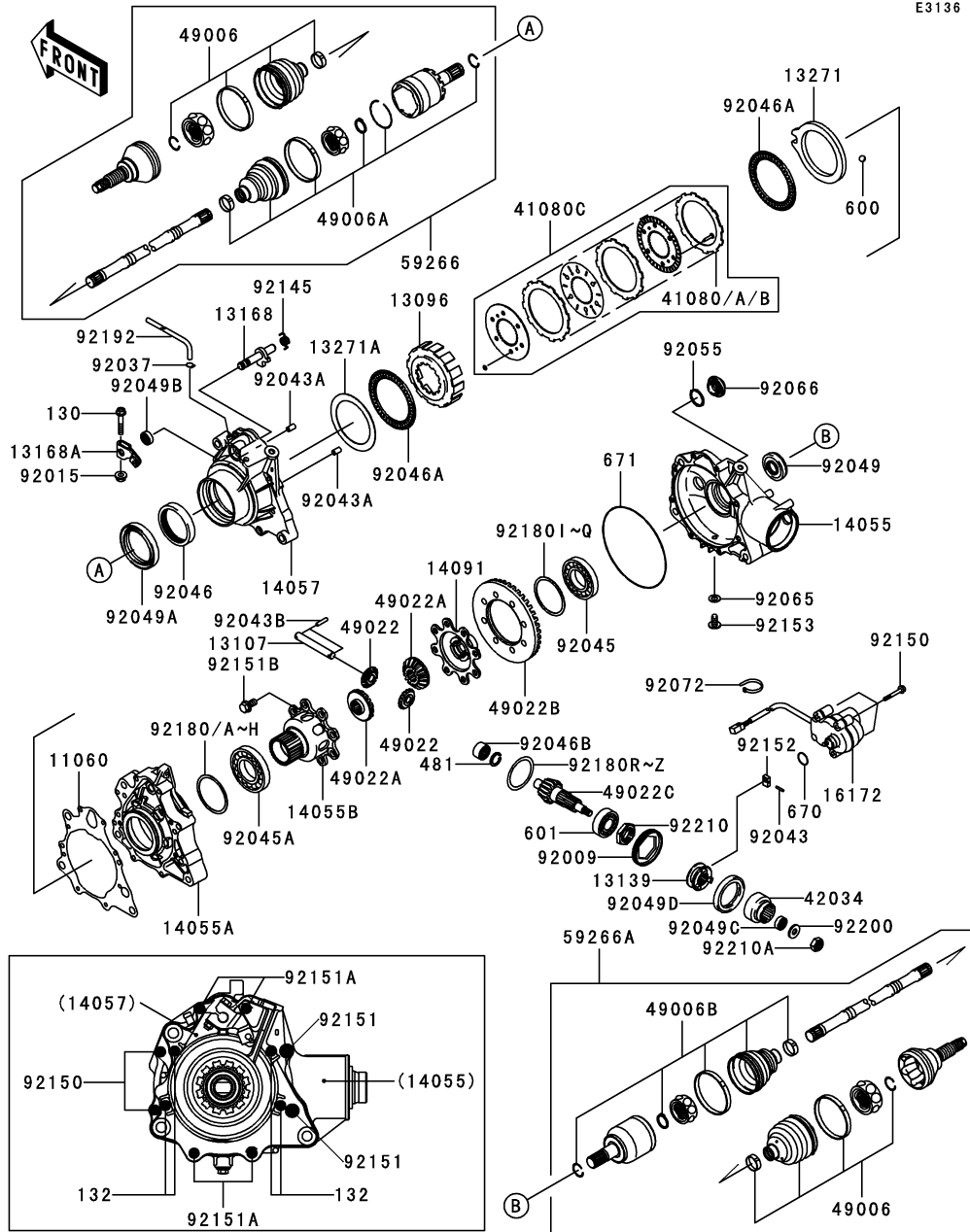

Ref. No.	Part No.	Description	Quantity-KVF750			
			Spec Code		'08	'09
			D8F	D9F		
92046A	92046-1286	BEARING-NEEDLE,AK1116			2	2
92046B	92046-1297	BEARING-NEEDLE,AJ501515W			1	1
92049	92049-1534	SEAL-OIL,SDD7 22X48X7HS			1	1
92049A	92049-1536	SEAL-OIL,HTCY 62X81X10.5			1	1
92049B	92049-1550	SEAL-OIL,TC 12X22X7			1	1
92049C	92049-1572	SEAL-OIL,KB 13X19X13			1	1
92049D	92049-1573	SEAL-OIL,TCY 48X65X8			1	1
92055	92055-0122	RING-O			1	1
92065	92065-023	GASKET			1	1
92066	92066-1303	PLUG			1	1
92072	92072-1239	BAND,L=188			1	1
92145	92145-1344	SPRING,DIFF RETURN			1	1
92150	92150-1884	BOLT,6X45			5	5
92151	92151-1794	BOLT,8X50			2	2
92151A	92151-1795	BOLT,6X60			4	4
92151B	92151-1910	BOLT,10X19.5			8	8
92152	92152-1349	COLLAR			1	1
92153	92153-0870	BOLT,8X15			1	1
92180	92180-1390	SHIM,62X71X0.15	AR		AR	AR
92180A	92180-1391	SHIM,62X71X0.20	AR		AR	AR
92180B	92180-1392	SHIM,62X71X0.50	AR		AR	AR
92180C	92180-1393	SHIM,62X71X0.70	AR		AR	AR
92180D	92180-1394	SHIM,62X71X0.80	AR		AR	AR
92180E	92180-1395	SHIM,62X71X0.90	AR		AR	AR
92180F	92180-1396	SHIM,62X71X1.00	AR		AR	AR
92180G	92180-1397	SHIM,62X71X1.10	AR		AR	AR
92180H	92180-1398	SHIM,62X71X1.20	AR		AR	AR
92180I	92180-1399	SHIM,32X42X0.15	AR		AR	AR
92180J	92180-1400	SHIM,32X42X0.20	AR		AR	AR
92180K	92180-1401	SHIM,32X42X0.50	AR		AR	AR
92180L	92180-1402	SHIM,32X42X0.70	AR		AR	AR
92180M	92180-1403	SHIM,32X42X0.80	AR		AR	AR
92180N	92180-1404	SHIM,32X42X0.90	AR		AR	AR
92180O	92180-1405	SHIM,32X42X1.00	AR		AR	AR
92180P	92180-1406	SHIM,32X42X1.10	AR		AR	AR
92180Q	92180-1407	SHIM,32X42X1.20	AR		AR	AR
92180R	92180-1408	SHIM,50X61X0.15	AR		AR	AR
92180S	92180-1409	SHIM,50X61X0.20	AR		AR	AR
92180T	92180-1410	SHIM,50X61X0.50	AR		AR	AR
92180U	92180-1411	SHIM,50X61X0.70	AR		AR	AR

This catalog covers:

'08~'09 KVF750 D8F/D9F Engine

GRID NO.

D-7

This grid covers:

Drive Shaft-Front(3/3)

E3136

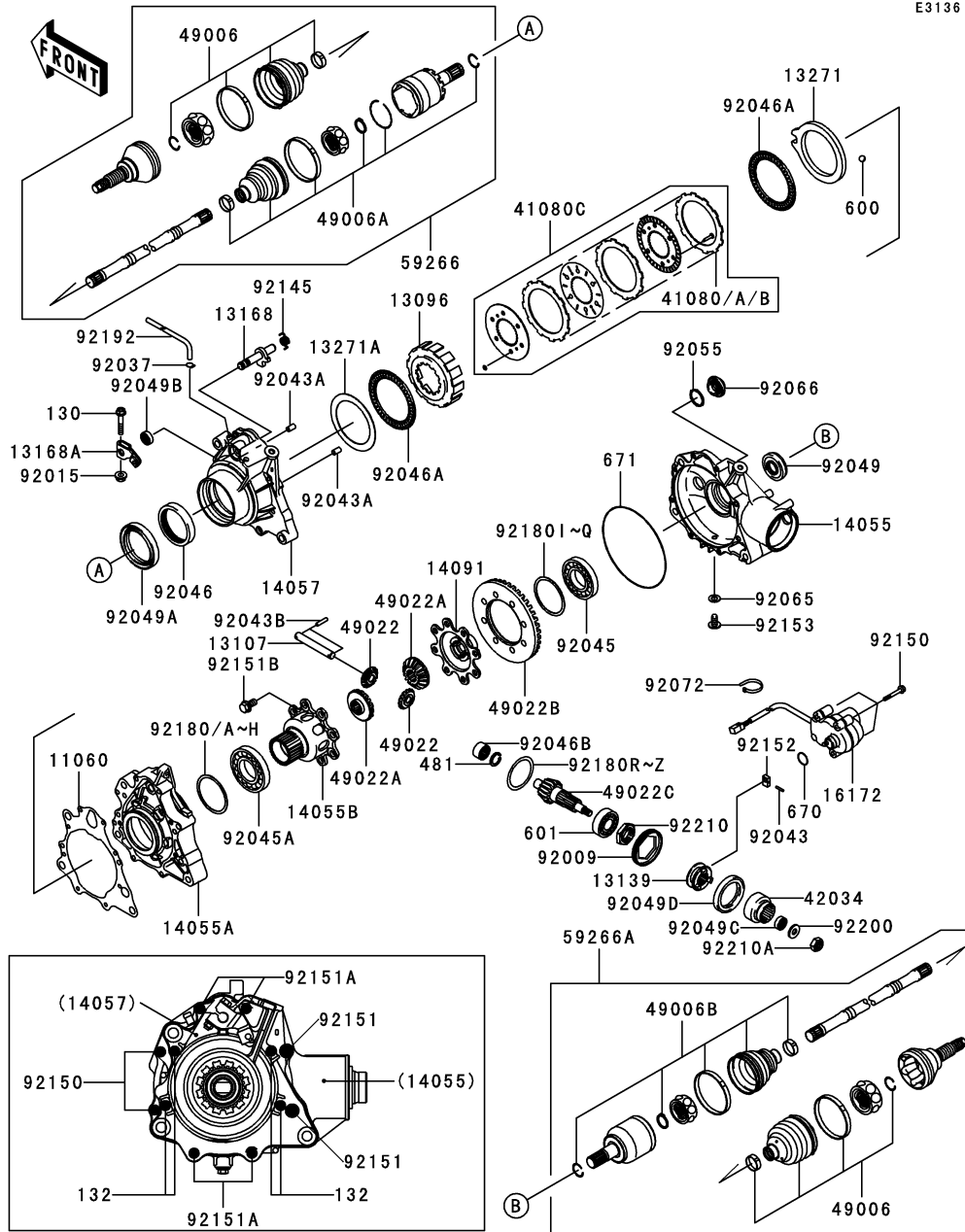

Ref. No.	Part No.	Description	Spec Code	Quantity-KVF750			
				'08	'09		
				D8F	D9F		
92180V	92180-1412	SHIM,50X61X0.80	AR	AR			
92180W	92180-1413	SHIM,50X61X0.90	AR	AR			
92180X	92180-1414	SHIM,50X61X1.00	AR	AR			
92180Y	92180-1415	SHIM,50X61X1.10	AR	AR			
92180Z	92180-1416	SHIM,50X61X1.20	AR	AR			
92192	92192-0716	TUBE,7X12X760	1	1			
92200	92200-1635	WASHER,10X24X2.5	1	1			
92210	92210-1225	NUT,25MM	1	1			
92210A	92210-1351	NUT,LOCK,10MM	1	1			
130	130BA0635	BOLT-FLANGED,6X35	1	1			
132	132BD0630	BOLT-FLANGED-SMALL,6X30	4	4			
481	481J2500	CIRCLIP-TYPE-C,25MM	1	1			
600	600A1100	BALL-STEEL,11/32"	6	6			
601	601A6305	BEARING-BALL,#6305	1	1			
670	670D3022	O RING	1	1			
671	671D25145	O RING	1	1			

This catalog covers:

'08~'09 KVF750 D8F/D9F Engine

GRID NO.

D-8

This grid covers:

Drive Shaft-Rear(1/2)

E3137

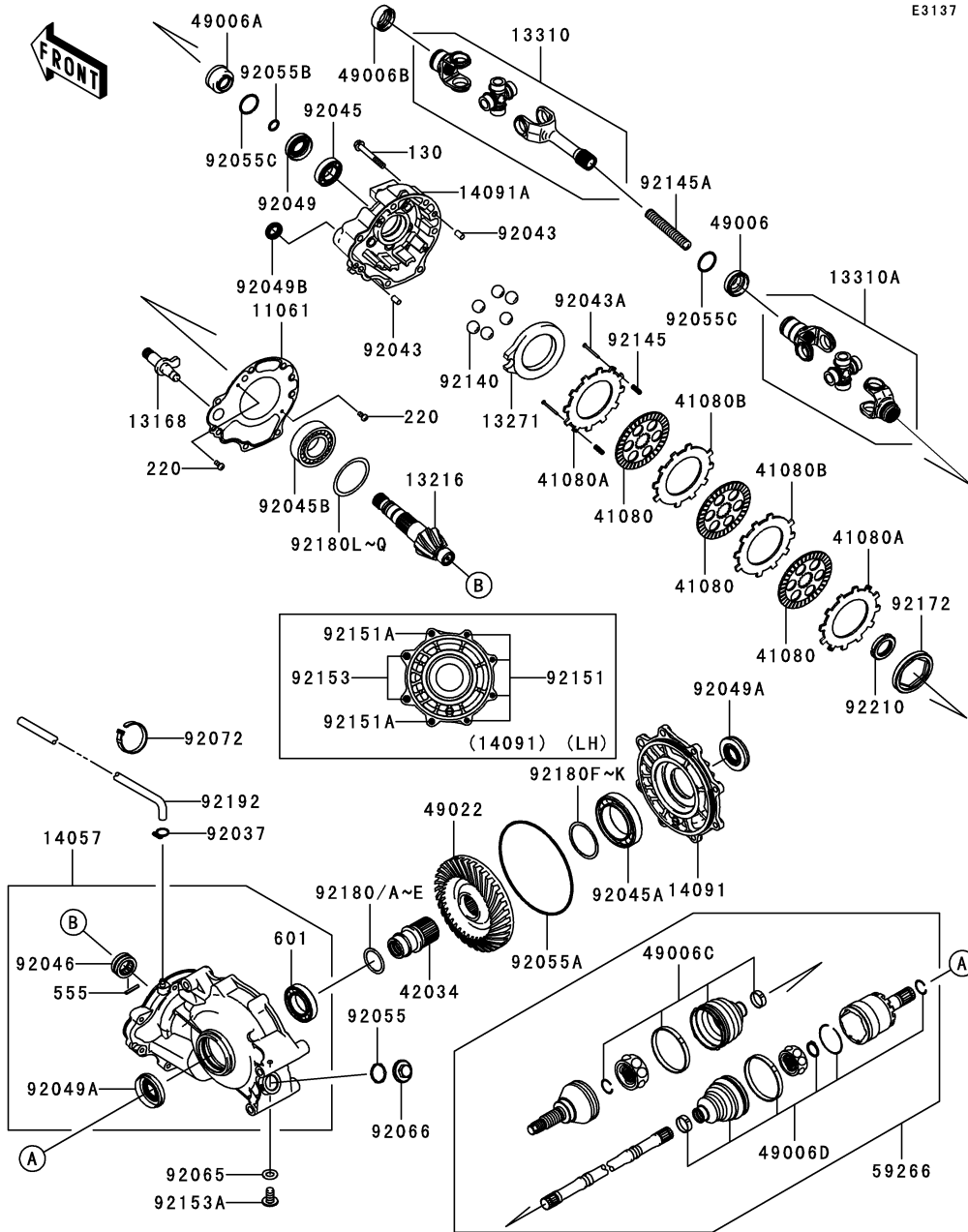

Ref. No.	Part No.	Description	Spec Code	Quantity-KVF750			
				'08	'09		
				D8F	D9F		
11061	11061-0059	GASKET,SOHT METAL	1	1			
13168	13168-0042	LEVER,BRAKE	1	1			
13216	13216-0017	GEAR-COMP	1	1			
13271	13271-0539	PLATE,CAM	1	1			
13310	13310-0013	SHAFT-ASSY,ENGINE SIDE	1	1			
13310A	13310-0014	SHAFT-ASSY,GEAR-ASSY SIDE	1	1			
14057	14057-0002	CASE-COMP-GEAR	1	1			
14091	14091-0142	COVER,RH	1	1			
14091A	14091-0143	COVER,FR	1	1			
41080	41080-1482	DISC,FRICITION	3	3			
41080A	41080-1483	DISC,PRESSURE	2	2			
41080B	41080-1484	DISC,SEPARATER	2	2			
42034	42034-0006	COUPLING	1	1			
49006	49006-0007	BOOT	1	1			
49006A	49006-0008	BOOT	1	1			
49006B	49006-0021	BOOT	1	1			
49006C	49006-0064	BOOT,UJ	2	2			
49006D	49006-0065	(OPTION) BOOT,DOJ	2	2			
49022	49022-0009	(OPTION) GEAR-BEVEL,35T	1	1			
59266	59266-0023	JOINT-BALL	2	2			
92037	92037-1104	CLAMP,HOSE	1	1			
92043	92043-1567	PIN,8X14	2	2			
92043A	92043-1617	PIN,3X35	2	2			
92045	92045-0077	BEARING-BALL,#6005	1	1			
92045A	92045-0078	BEARING-BALL,55X90X18	1	1			
92045B	92045-0099	BEARING-BALL,BX30-1C3 UR3	1	1			
92046	92046-1280	BEARING-NEEDLE,AH502504A	1	1			
92049	92049-0028	SEAL-OIL,HTGY 24X45X9.5	1	1			
92049A	92049-0029	SEAL-OIL,SDD7 25X57X7 HS	2	2			
92049B	92049-1537	SEAL-OIL,TC17X28X6	1	1			
92055	92055-0122	RING-O	1	1			
92055A	92055-1631	RING-O,158.5X3.70	1	1			
92055B	92055-1633	RING-O,18X24X3	1	1			
92055C	92055-1693	RING-O,30X35X2.5	2	2			
92065	92065-023	GASKET	1	1			
92066	92066-1303	PLUG	1	1			
92072	92072-056	BAND,L=186	5	5			
92140	92140-1064	BALL,D/O#12	6	6			

This catalog covers:

'08~'09 KVF750 D8F/D9F Engine

GRID NO.

D-9

This grid covers:

Drive Shaft-Rear(2/2)

E3137

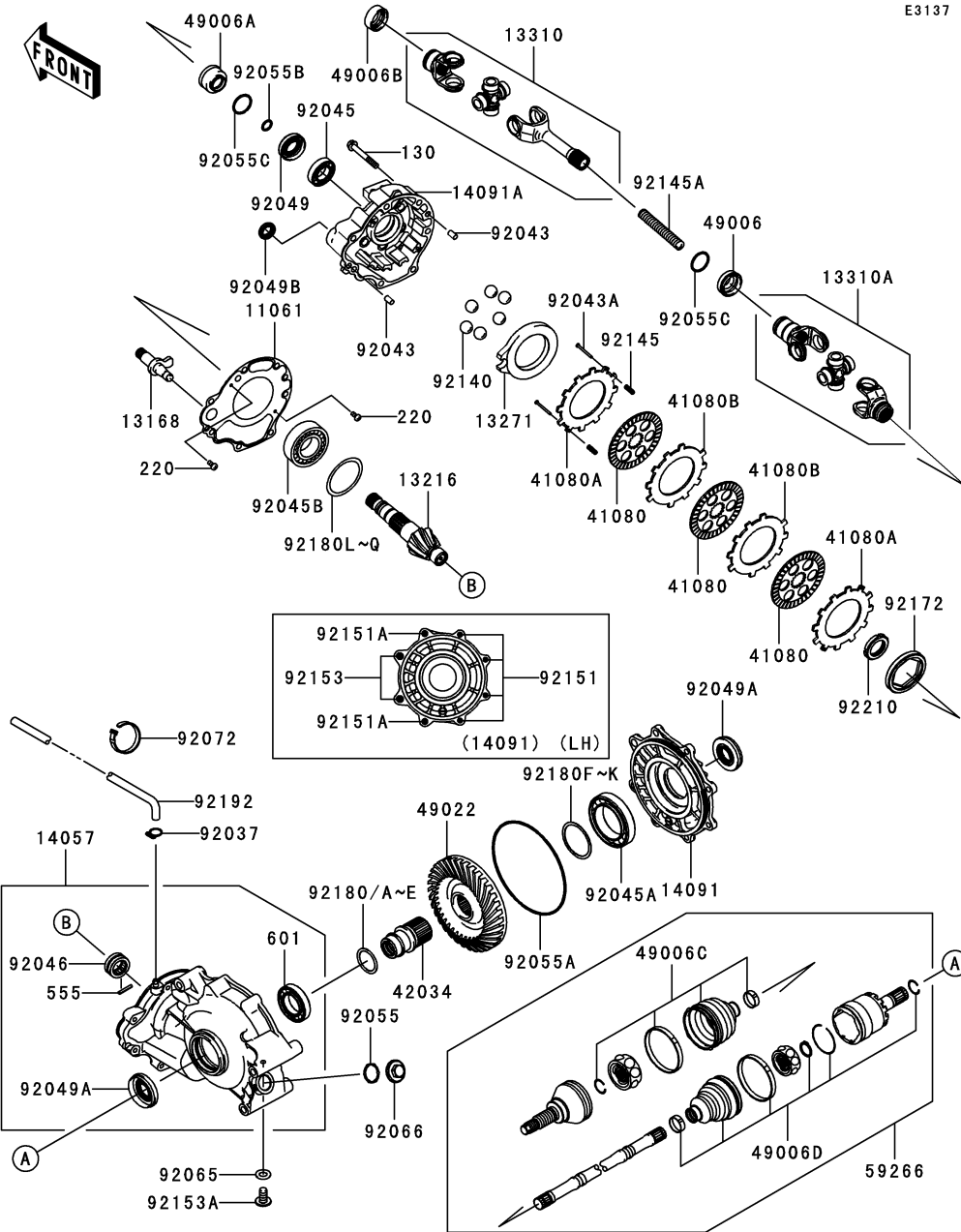

Ref. No.	Part No.	Description	Spec Code	Quantity-KVF750	
				'08	'09
				D8F	D9F
92145	92145-1301	SPRING,RR BRAKE	2	2	
92145A	92145-1304	SPRING,PROPELLER SHAFT	1	1	
92151	92151-1908	BOLT,8X30	4	4	
92151A	92151-1909	BOLT,10X35	2	2	
92153	92153-0311	BOLT,12X35	2	2	
92153A	92153-0870	BOLT,8X15	1	1	
92172	92172-0341	SCREW,SET,75X10	1	1	
92180	92180-0161	SHIM,35.2X44.0X1.2	AR	AR	
92180A	92180-0162	SHIM,35.2X44.0X1.0	AR	AR	
92180B	92180-0163	SHIM,35.2X44.0X0.8	AR	AR	
92180C	92180-0164	SHIM,35.2X44.0X0.5	AR	AR	
92180D	92180-0165	SHIM,35.2X44.0X0.2	AR	AR	
92180E	92180-0166	SHIM,35.2X44.0X0.15	AR	AR	
92180F	92180-1417	SHIM,55X64X0.15	AR	AR	
92180G	92180-1418	SHIM,55X64X0.20	AR	AR	
92180H	92180-1419	SHIM,55X64X0.50	AR	AR	
92180I	92180-1420	SHIM,55X64X0.80	AR	AR	
92180J	92180-1421	SHIM,55X64X1.00	AR	AR	
92180K	92180-1422	SHIM,55X64X1.20	AR	AR	
92180L	92180-1423	SHIM,60X72X0.15	AR	AR	
92180M	92180-1424	SHIM,60X72X0.20	AR	AR	
92180N	92180-1425	SHIM,60X72X0.50	AR	AR	
92180O	92180-1426	SHIM,60X72X0.80	AR	AR	
92180P	92180-1427	SHIM,60X72X1.00	AR	AR	
92180Q	92180-1428	SHIM,60X72X1.20	AR	AR	
92192	92192-0210	TUBE,BREATHER,L=1680MM	1	1	
92210	92210-1294	NUT,30MM	1	1	
130	130CD0860	BOLT-FLANGED,8X60	7	7	
220	220AA0408	SCREW-PAN-CROS,4X8	2	2	
555	555A0428	PIN-SPRING	1	1	
601	601A6007	BEARING-BALL,#6007	1	1	

This catalog covers:

'08~'09 KVF750 D8F/D9F Engine

GRID NO.

D-10

This grid covers:

Control

E7110

Ref. No.	Part No.	Description	Spec Code	Quantity-KVF750			
				'08	'09		
				D8F	D9F		
11052	11052-1476	BRACKET,CONTROL	1	1			
13070	13070-1396	GUIDE,CONTROL SHAFT	1	1			
13236	13236-0034	LEVER-COMP,SHIFT	1	1			
39111	39111-1174	ROD-TIE,SHIFT	1	1			
39112	39112-1079	RODEND-TIE	1	1			
39112A	39112-1084	RODEND-TIE,CONTROL PIVOT	1	1			
39145	39145-1121	TRIM-SEAL,CONTROL GUIDE	1	1			
46075	46075-0046	GRIP,SHIFT	1	1			
92015	92015-1432	NUT,8MM	2	2			
92049	92049-1458	SEAL-OIL	2	2			
92145	92145-0130	SPRING	1	1			
92152	92152-1222	COLLAR,RODEND-TIE	1	1			
92210	92210-1242	NUT,8MM	1	1			
92210A	92210-1284	NUT,LH,THREAD 8MM	1	1			
130	130CD0825	BOLT-FLANGED,8X25	2	2			
132	132BB0650	BOLT-FLANGED-SMALL,6X50	1	1			
315	315AA1000	NUT-HEX-FINE,10MM	1	1			
318	318BA0800	NUT-HEX-SMALL,8MM	1	1			

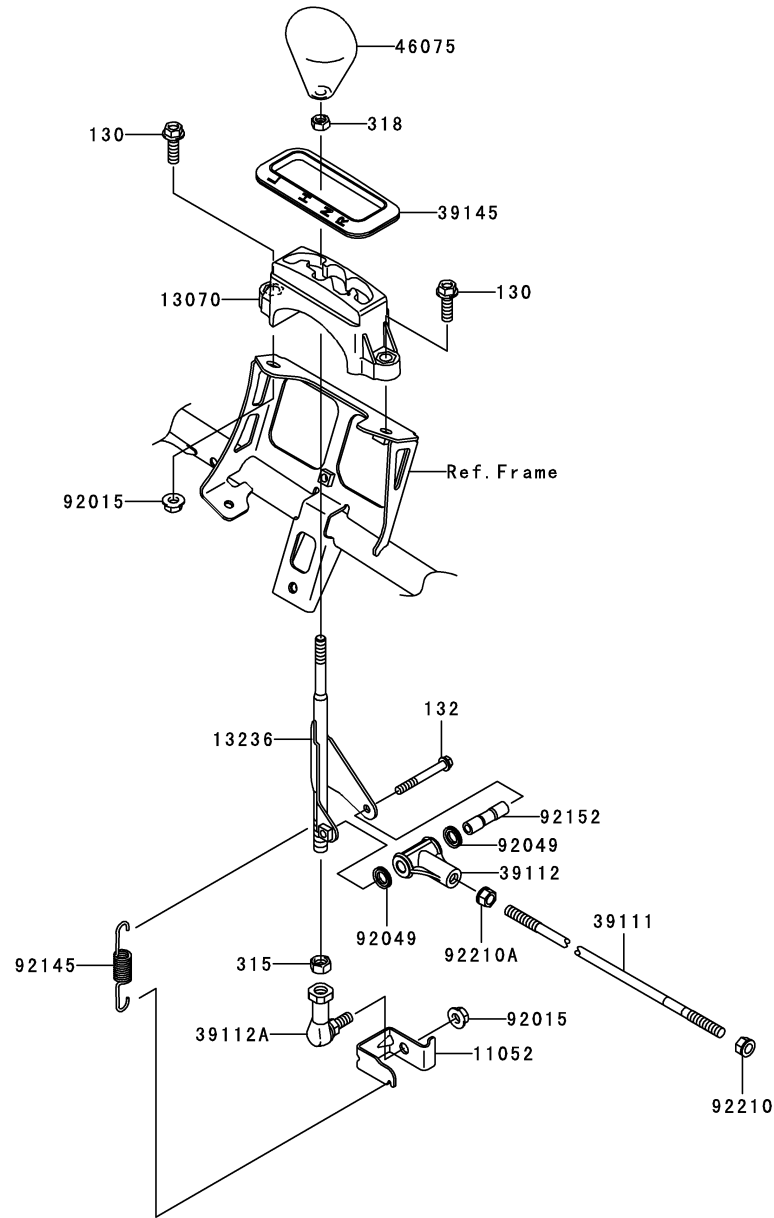

This catalog covers:

'08~'09 KVF750 D8F/D9F Chassis

GRID NO.

E-3

This grid covers:

Frame

F2120

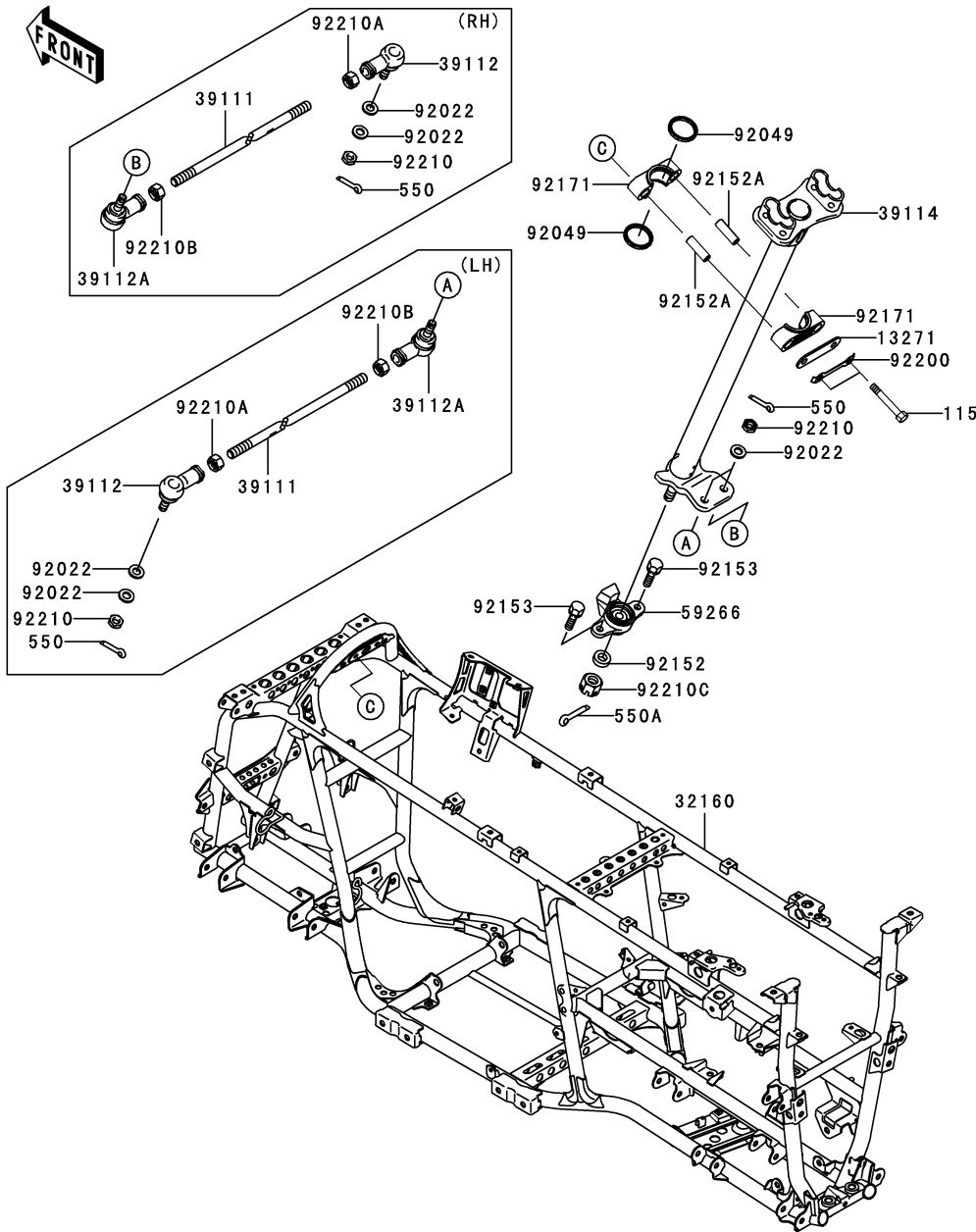

Ref. No.	Part No.	Description	Quantity-KVF750			
			Spec Code		'08	'09
			D8F	D9F		
13271	13271-7506	PLATE,STEERING,CLAMP			1	1
32160	32160-0227	FRAME-COMP			1	1
39111	39111-0023	ROD-TIE			2	2
39112	39112-0009	RODEND-TIE,RIGHT HANDED			2	2
39112A	39112-0010	RODEND-TIE,LEFT HANDED			2	2
39114	39114-0006	SHAFT-COMP-STRG			1	1
59266	59266-1125	JOINT-BALL			1	1
92022	92022-3742	WASHER,10.2X20X1.5			6	6
92049	92049-7501	SEAL-OIL,SR31.8X37.5X3.8LR			2	2
92152	92152-1351	COLLAR,12X21.3X7			1	1
92152A	92152-7501	COLLAR,9.1X13.95X42			2	2
92153	92153-1065	BOLT,8X30			2	2
92171	92171-7501	CLAMP,STEERING			2	2
92200	92200-0384	WASHER,STEERING CLAMP			1	1
92210	92210-1184	NUT,LOCK,10MM			4	4
92210A	92210-1385	NUT,RIGHT HANDED			2	2
92210B	92210-1386	NUT,LEFT HANDED			2	2
92210C	92210-7501	NUT,12MM			1	1
115	115CB0855	BOLT-SMALL-UPSET,8X55			2	2
550	550AA2015	PIN-COTTER,2.0X15			4	4
550A	550AA3025	PIN-COTTER,3.0X25			1	1

This catalog covers:

'08~'09 KVF750 D8F/D9F Chassis

GRID NO.

E-4

This grid covers:

Engine Mount

F2122

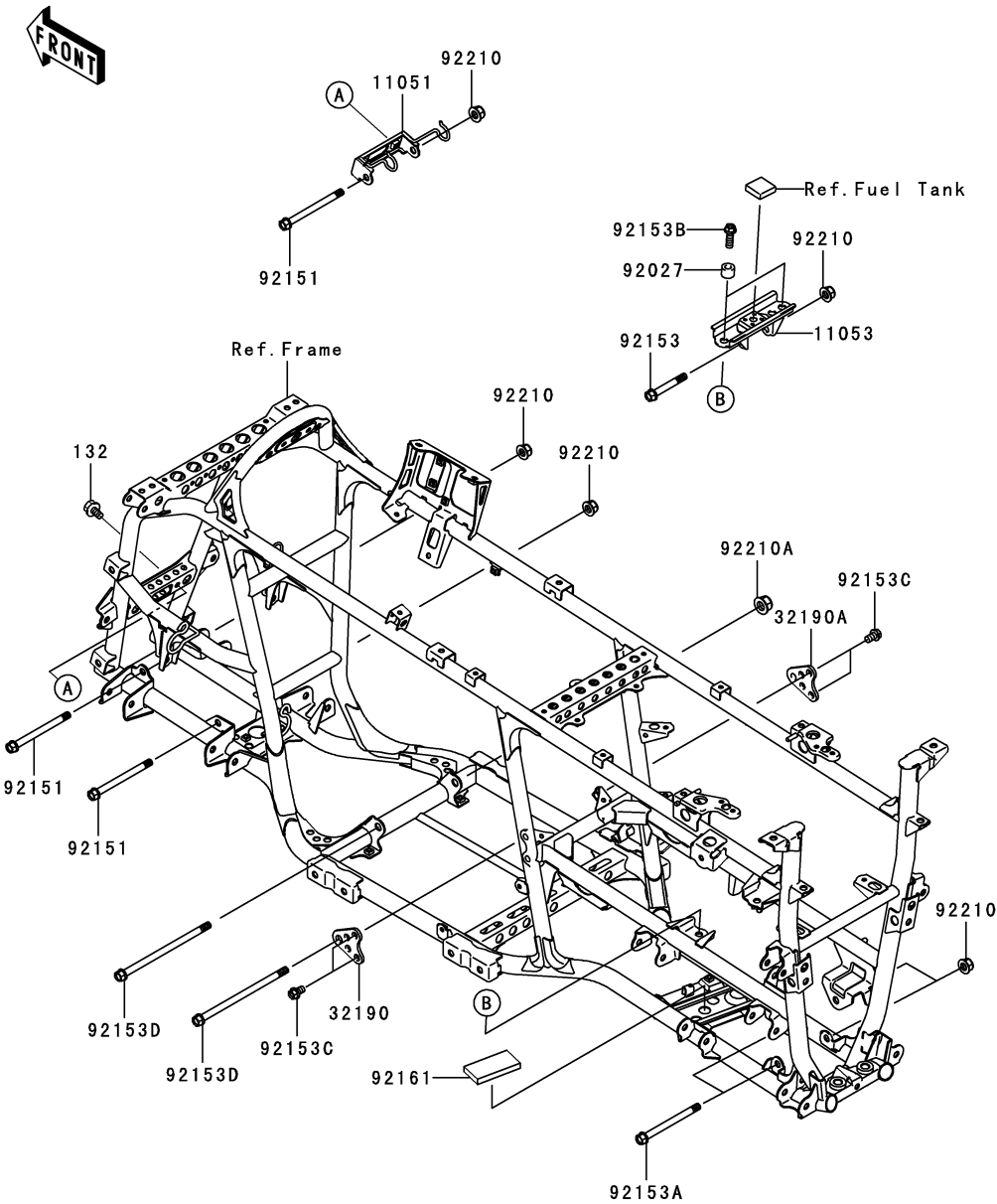

Ref. No.	Part No.	Description	Spec Code	Quantity-KVF750			
				'08	'09		
				D8F	D9F		
11051	11051-1929	BRACKET,FRONT DIFF	1	1			
11053	11053-1592	BRACKET,REAR DIFF,TOP	1	1			
32190	32190-0059	BRACKET-ENGINE,RR,UPP,LH	1	1			
32190A	32190-0060	BRACKET-ENGINE,RR,UPP,RH	1	1			
92027	92027-1472	COLLAR,FRONT AXLE,L=14.5	2	2			
92151	92151-1914	BOLT,FLANGED,10X120	3	3			
92153	92153-0871	BOLT,FLANGED,10X70	1	1			
92153A	92153-0872	BOLT,FLANGED,10X120	2	2			
92153B	92153-0930	BOLT,FLANGED,10X30	2	2			
92153C	92153-0991	BOLT,FLANGED,10X16	4	4			
92153D	92153-1502	BOLT,FLANGED,12X190	2	2			
92161	92161-0215	DAMPER	1	1			
92210	92210-1081	NUT,LOCK,FLANGED,10MM	6	6			
92210A	92210-1150	NUT,LOCK,FLANGED,12MM	1	1			
132	132BB0814	BOLT-FLANGED-SMALL,8X14	2	2			

This catalog covers:

'08~'09 KVF750 D8F/D9F Chassis

GRID NO.

E-5

This grid covers:

Frame Fittings(1/2)

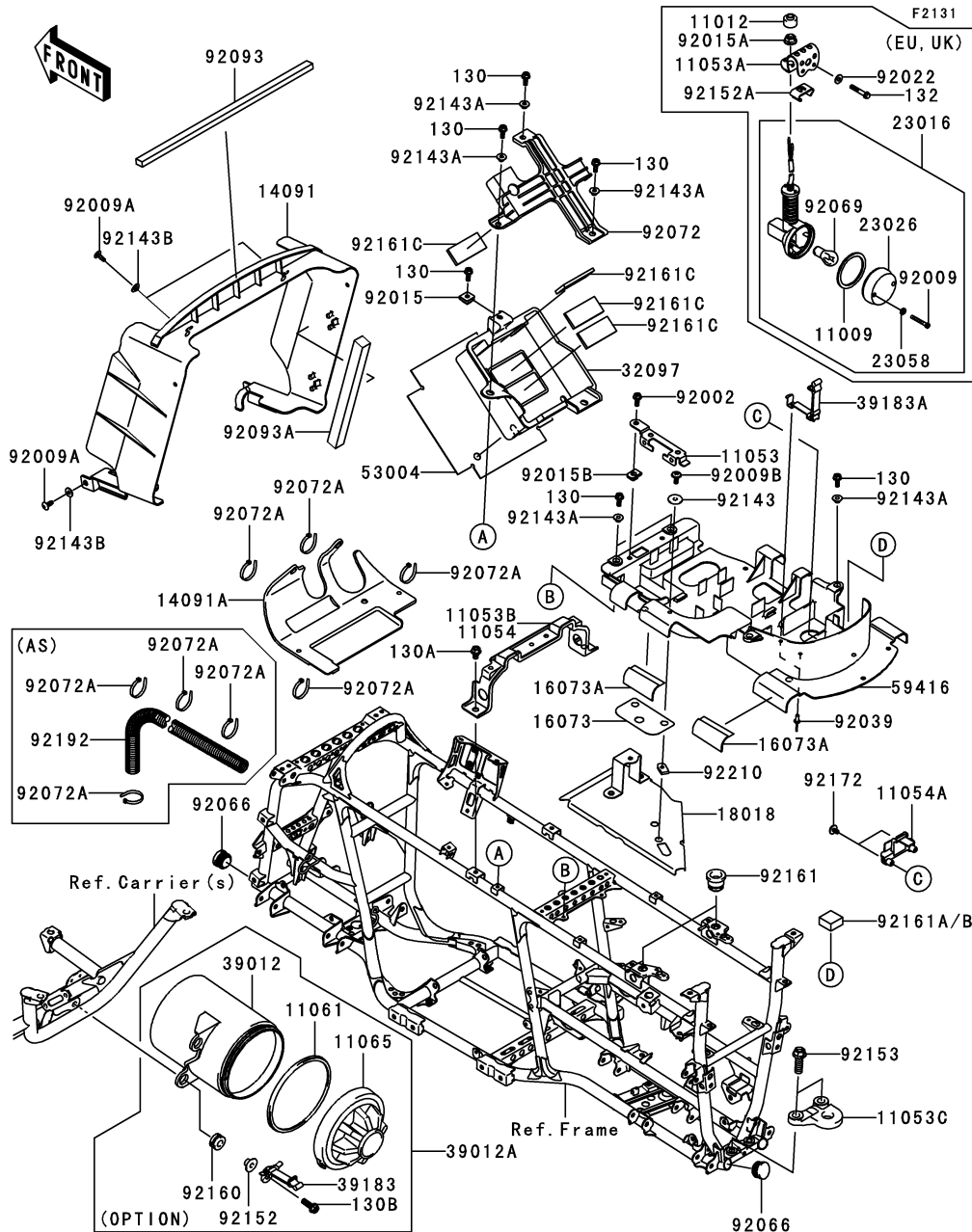

Ref. No.	Part No.	Description	Spec Code	Quantity-KVF750			
				'08	'09		
				D8F	D9F		
11009	11009-1373	GASKET					
	L-----		EU,UK	1	1		
11012	11012-1367	CAP					
	L-----		EU,UK	1	1		
11053	11053-0937	BRACKET,FUSE ASSY					
11053A	11053-0958	BRACKET,REVERSE LAMP					
	L-----		EU,UK	1	1		
11053B	11053-0969	BRACKET,SEAT&BATTERY BAND					
				1			
11053C	11053-1638	BRACKET,TRAILER HITCH					
				1	1		
11054	11054-1236	BRACKET,SEAT&BATTERY BAND					
				1	1		
11054A	11054-1318	BRACKET,RELAY					
				1	1		
11061	11061-0072	GASKET,TOOL CASE					
	(OPTION)			1	1		
11065	11065-0088	CAP,TOOL CASE					
	(OPTION)			1	1		
14091	14091-0338	COVER,RADIATOR					
				1	1		
14091A	14091-0540	COVER,AIR CLEANER					
				1	1		
16073	16073-0035	INSULATOR,ELECTRIC CASE					
				1	1		
16073A	16073-0036	INSULATOR,ELECTRIC CASE					
				2	2		
18018	18018-0009	PLATE-HEAT GUARD					
				1	1		
23016	23016-1182	LAMP-ASSY,REVERSE					
	L-----		EU,UK	1	1		
23026	23026-1227	LENS,REVERSE LAMP					
	L-----		EU,UK	1	1		
23058	23058-002	WASHER,PLAIN,4MM					
	L-----		EU,UK	2	2		
32097	32097-0009	CASE-BATTERY					
				1	1		
39012	39012-0005	CASE-STORAGE					
	(OPTION)			1	1		
39012A	39012-5013	CASE-STORAGE,ASSY					
	(OPTION)			1	1		
39183	39183-0003	BAND-ASSY,TOOL BAG					
	(OPTION)			1	1		
39183A	39183-1065	BAND-ASSY,TOOL BAG					
				1	1		
53004	53004-0002	MAT,BATTERY CASE					
				1	1		
59416	59416-0004	CASE-ELECTRIC					
				1	1		
92002	92002-1571	BOLT,6X16					
				1	1		
92009	92009-1069	SCREW,TAPPING,4X25					
	L-----		EU,UK	2	2		
92009A	92009-1166	SCREW,TAPPING,6X16					
				4	4		
92009B	92009-1621	SCREW,6X16					
				1	1		
92015	92015-1094	NUT,6MM					
				1	1		
92015A	92015-1356	NUT,10MM					
	L-----		EU,UK	1	1		

This catalog covers:

'08~'09 KVF750 D8F/D9F Chassis

GRID NO.

E-6

This grid covers:

Frame Fittings(2/2)

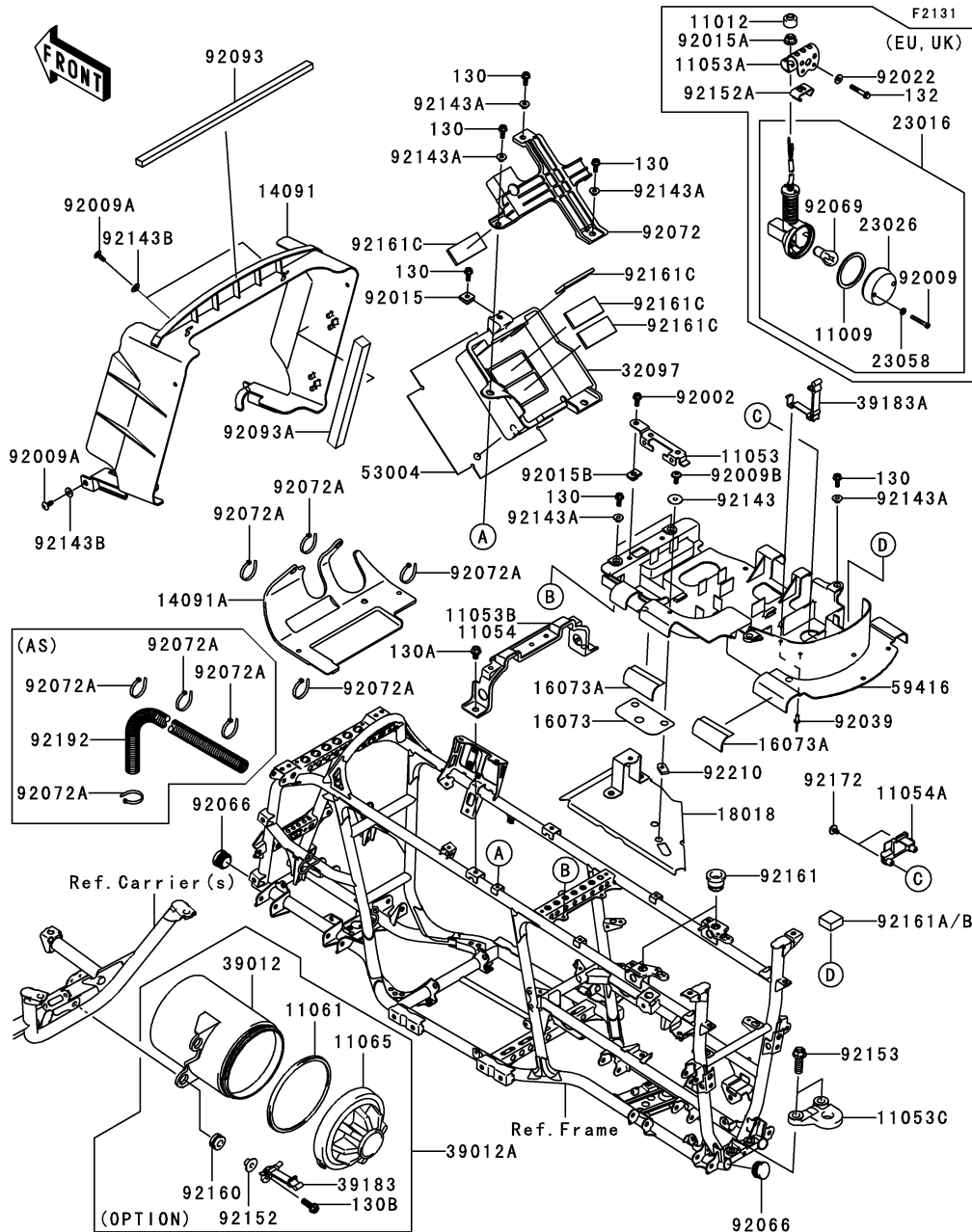

Ref. No.	Part No.	Description	Spec Code	Quantity-KVF750	
				'08	'09
				D8F	D9F
92015B	92015-1602	NUT,6MM		1	1
92022	92022-1342	WASHER,6.5X16X2			
	L-----		EU,UK	2	2
92039	92039-3719	RIVET,4.8MM		2	2
92066	92066-0036	PLUG		4	4
92069	92069-085	BULB,12V 10W			
	L-----		EU,UK	1	1
92072	92072-0033	BAND,BATTERY		1	1
92072A	92072-1239	BAND,L=188			
	L-----		EU,UK	4	4
	L-----		AS	8	8
92093	92093-0024	SEAL,L=408		1	1
92093A	92093-0028	SEAL,L=250		2	2
92143	92143-1025	COLLAR,L=6.5		1	1
92143A	92143-1057	COLLAR		7	7
92143B	92143-1087	COLLAR		4	4
92152	92152-0155	COLLAR		2	2
	(OPTION)				
92152A	92152-0191	COLLAR			
	L-----		EU,UK	1	1
92153	92153-0847	BOLT,FLANGED,12X35		2	2
92160	92160-1151	DAMPER		2	2
	(OPTION)				
92161	92161-0048	DAMPER		2	2
92161A	92161-0572	DAMPER,SENSOR		1	
92161B	92161-0618	DAMPER,SENSOR			1
92161C	92161-1127	DAMPER		4	4
92172	92172-0175	SCREW,TAPPING,5X16		2	2
92192	92192-0572	TUBE,CORRUGATED,L=840			
	L-----		AS	1	1
92210	92210-1331	NUT		1	1
130	130BB0616	BOLT-FLANGED,6X16		8	8
130A	130BB0812	BOLT-FLANGED,8X12		2	2
130B	130BB0825	BOLT-FLANGED,8X25		2	2
	(OPTION)				
132	132BB0635	BOLT-FLANGED-SMALL,6X35			
	L-----		EU,UK	2	2

This catalog covers:

'08~'09 KVF750 D8F/D9F Chassis

GRID NO.

E-7

This grid covers:

Front Suspension

F2152

Ref. No.	Part No.	Description	Spec Code	Quantity-KVF750			
				'08	'09		
				D8F	D9F		
39007	39007-0064	ARM-SUSP,FR,LWR,LH		1	1		
39007A	39007-0065	ARM-SUSP,FR,LWR,RH		1	1		
39007B	39007-0066	ARM-SUSP,FR,UPP,LH		1	1		
39007C	39007-0067	ARM-SUSP,FR,UPP,RH		1	1		
39186	39186-0033	KNUCKLE ASSY,FR,LH		1	1		
39186A	39186-0034	KNUCKLE ASSY,FR,RH		1	1		
42036	42036-0016	SLEEVE,SUSPENSION ARM		2	2		
42036A	42036-1376	SLEEVE		2	2		
55020	55020-0109-6Z	GUARD,FRONT ARM,LH,F.BLACK		1	1		
55020A	55020-0110-6Z	GUARD,FRONT ARM,RH,F.BLACK		1	1		
59266	59266-0013	JOINT-BALL		4	4		
92015	92015-1415	NUT,FLANGED,10MM		6	6		
92022	92022-024	WASHER,7X16X1.2		6	6		
92022A	92022-1065	WASHER,12.3X22X1.6		4	4		
92022B	92022-1829	WASHER,10.2X16X1		AR	AR		
92033	92033-1274	RING-SNAP,55MM		2	2		
92045	92045-0095	BEARING-BALL,30BWD08ACA13		2	2		
92046	92046-1046	BEARING-NEEDLE		4	4		
92049	92049-1223	SEAL-OIL,MHA17245.7F		12	12		
92150	92150-1384	BOLT,FLANGED,10X63		4	4		
92150A	92150-1686	BOLT,FLANGED,10X150		2	2		
92152	92152-1455	COLLAR,10X17X14.5		6	6		
92210	92210-0395	NUT,CASTLE,12MM		4	4		
132	132BB0612	BOLT-FLANGED-SMALL,6X12		6	6		
481	481J2400	CIRCLIP		6	6		
550	550AA3025	PIN-COTTER,3.0X25		4	4		

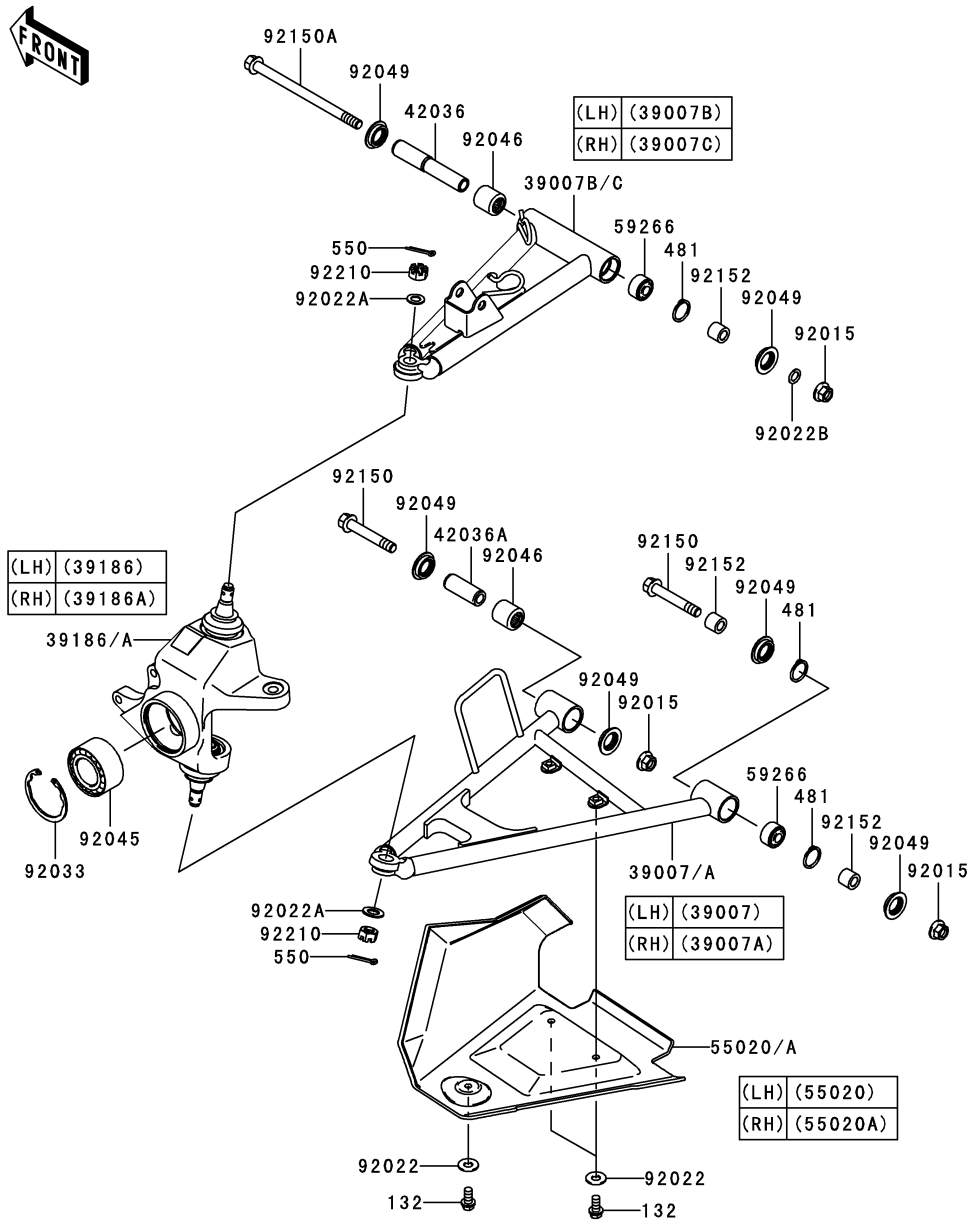

This catalog covers:

'08~'09 KVF750 D8F/D9F Chassis

GRID NO.

E-8

This grid covers:

Rear Suspension

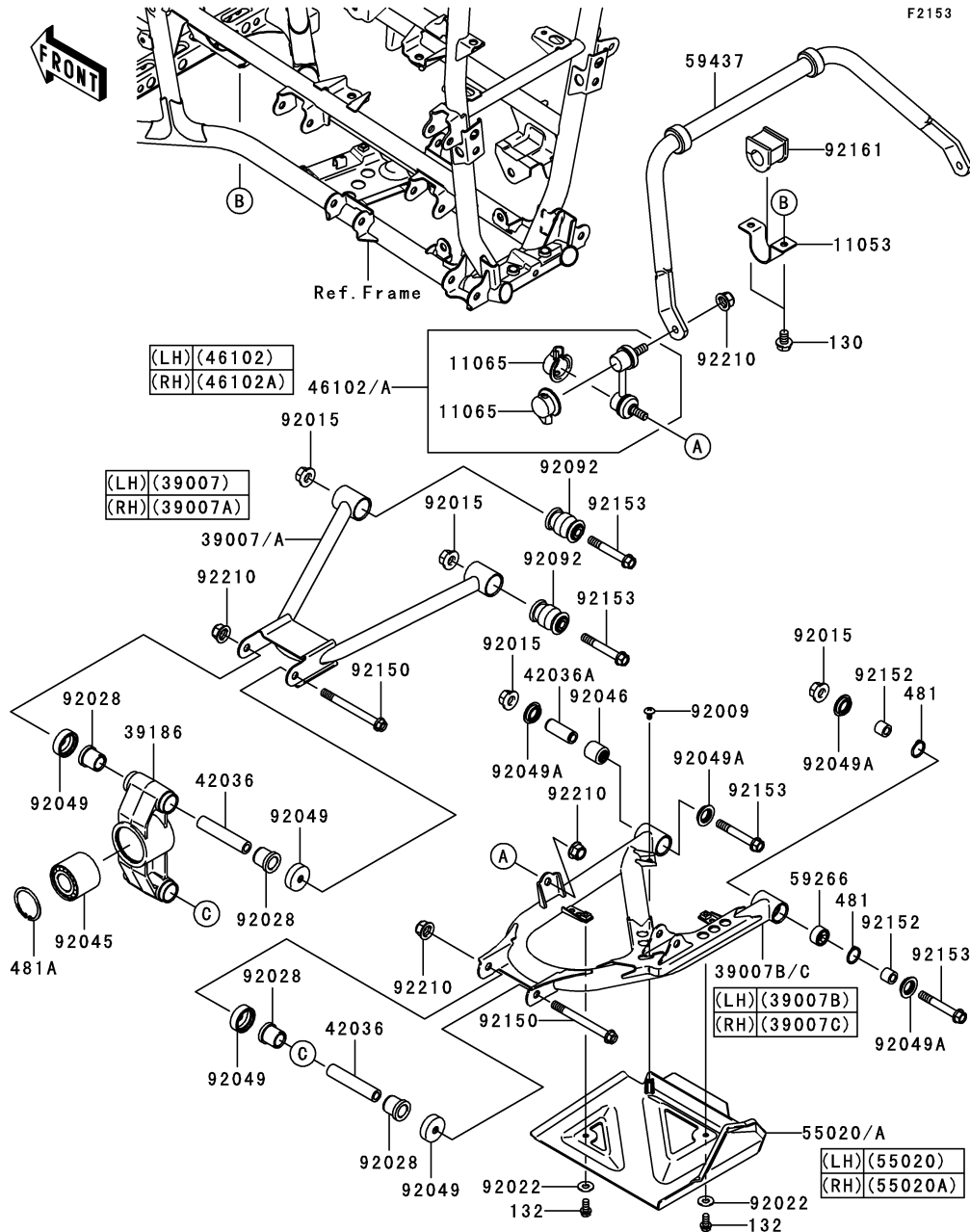

Ref. No.	Part No.	Description	Quantity-KVF750			
			Spec Code		'08	'09
			D8F	D9F		
11053	11053-1833	BRACKET,STABILIZER			2	2
11065	11065-0086	CAP			4	4
39007	39007-0021	ARM-SUSP,RR,UPP,LH			1	1
39007A	39007-0022	ARM-SUSP,RR,UPP,RH			1	1
39007B	39007-0038	ARM-SUSP,RR,LWR,LH			1	1
39007C	39007-0039	ARM-SUSP,RR,LWR,RH			1	1
39186	39186-0030	KNUCKLE,RR			2	2
42036	42036-1190	SLEEVE,10X17X85.6			4	4
42036A	42036-1376	SLEEVE			2	2
46102	46102-0055	ROD,STABILIZER,LH			1	1
46102A	46102-0056	ROD,STABILIZER,RH			1	1
55020	55020-0166-6Z	GUARD,REAR ARM,LH,F.BLACK			1	1
55020A	55020-0167-6Z	GUARD,REAR ARM,RH,F.BLACK			1	1
59266	59266-0013	JOINT-BALL			2	2
59437	59437-0001	STABILIZER			1	1
92009	92009-1480	SCREW,6X12			2	2
92015	92015-1415	NUT,FLANGED,10MM			8	8
92022	92022-024	WASHER,7X16X1.2			4	4
92028	92028-1466	BUSHING			8	8
92045	92045-0094	BEARING-BALL,25BWD02ACA68			2	2
92046	92046-1046	BEARING-NEEDLE			2	2
92049	92049-1198	SEAL-OIL,KNUCKLE			8	8
92049A	92049-1223	SEAL-OIL,MHA17245.7F			8	8
92092	92092-0004	BUSHING-RUBBER			4	4
92150	92150-1624	BOLT,FLANGED,10X105			4	4
92152	92152-1455	COLLAR,10X17X14.5			4	4
92153	92153-0666	BOLT,FLANGED,10X70			8	8
92161	92161-0265	DAMPER			2	2
92210	92210-0276	NUT,LOCK,FLANGED,10MM			8	8
130	130BB0812	BOLT-FLANGED,8X12			4	4
132	132BB0612	BOLT-FLANGED-SMALL,6X12			4	4
481	481J2400	CIRCLIP			4	4
481A	481J5200	CIRCLIP			2	2

This catalog covers:

'08~'09 KVF750 D8F/D9F Chassis

GRID NO.

E-9

This grid covers:

Footrests

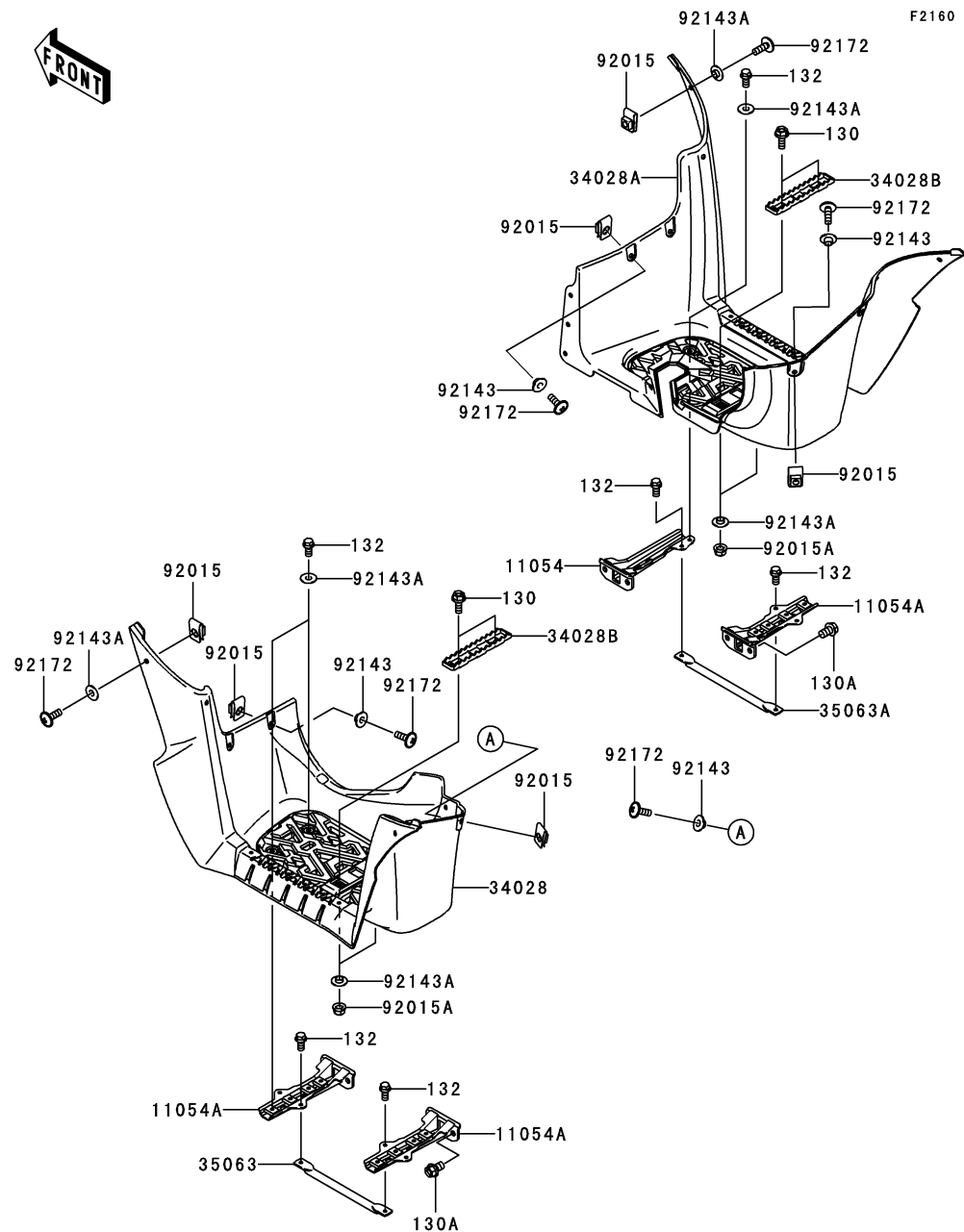

F2160

Ref. No.	Part No.	Description	Spec Code	Quantity-KVF750			
				'08	'09		
				D8F	D9F		
11054	11054-1229	BRACKET,FOOT BOARD,RH	1	1			
11054A	11054-1232	BRACKET,FOOT BOARD	3	3			
34028	34028-0054-6Z	STEP,FOOT BOARD,LH,F.BLACK	1	1			
34028A	34028-0055-6Z	STEP,FOOT BOARD,RH,F.BLACK	1	1			
34028B	34028-0087-21	STEP,FOOT PEG,F.BLACK	2	2			
35063	35063-0394	STAY,STEP,LH	1	1			
35063A	35063-0395	STAY,STEP,RH	1	1			
92015	92015-1602	NUT,6MM	17	17			
92015A	92015-1603	NUT,LOCK,FLANGED,6MM	4	4			
92143	92143-1057	COLLAR	4	4			
92143A	92143-1087	COLLAR	24	24			
92172	92172-0002	SCREW,6X18	17	17			
130	130BB0616	BOLT-FLANGED,6X16	4	4			
130A	130CB1016	BOLT-FLANGED,10X16	8	8			
132	132BB0612	BOLT-FLANGED-SMALL,6X12	11	11			

This catalog covers:

'08~'09 KVF750 D8F/D9F Chassis

GRID NO.

E-10

This grid covers:

Front Fender(s)(1/2)

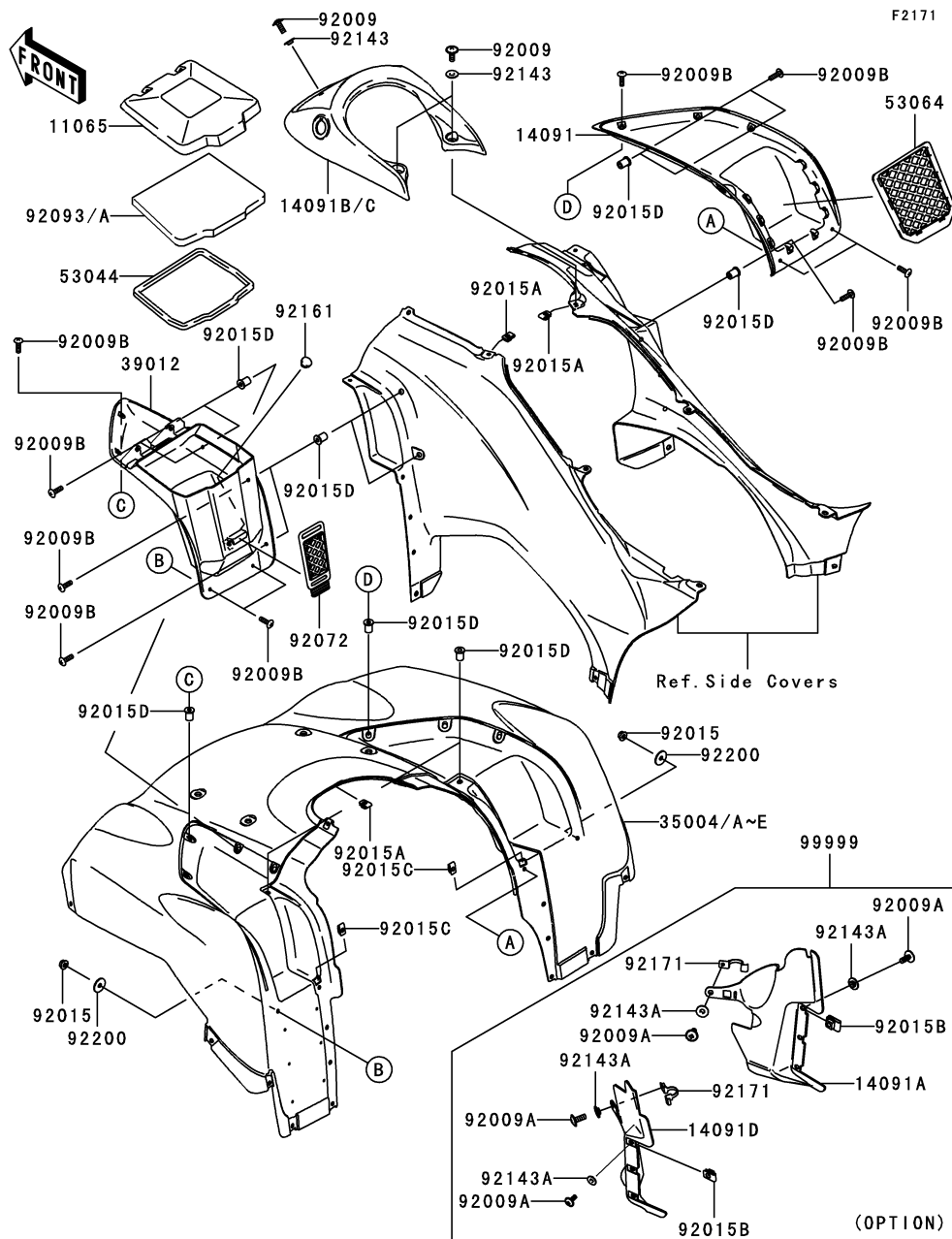

Ref. No.	Part No.	Description	Spec Code	Quantity-KVF750	
				'08	'09
				D8F	D9F
11065	11065-0194-6Z	CAP,STORAGE,F.BLACK	1	1	
14091	14091-0136-6Z	COVER,POCKET,RH,F.BLACK	1	1	
14091A	14091-0179	COVER,SIDE,INNER,RH	1	1	
14091B	14091-0270-286	COVER,TOP,W.GREEN			EU,UK
14091C	14091-0270-6Z	COVER,TOP,F.BLACK	1	1	
14091D	14091-0337	COVER,SIDE,INNER,LH	1	1	
35004	35004-0047-286	FENDER-FRONT,W.GREEN			EU,UK
35004A	35004-0047-290	FENDER-FRONT,L.GREEN			AS
35004B	35004-0047-839	FENDER-FRONT,BLACK			EU,UK
35004C	35004-0106-286	FENDER-FRONT,W.GREEN			EU,UK
35004D	35004-0106-290	FENDER-FRONT,L.GREEN			AS
35004E	35004-0106-839	FENDER-FRONT,BLACK			EU,UK

This catalog covers:

'08~'09 KVF750 D8F/D9F Chassis

GRID NO.

E-11

This grid covers:

Front Fender(s)(2/2)

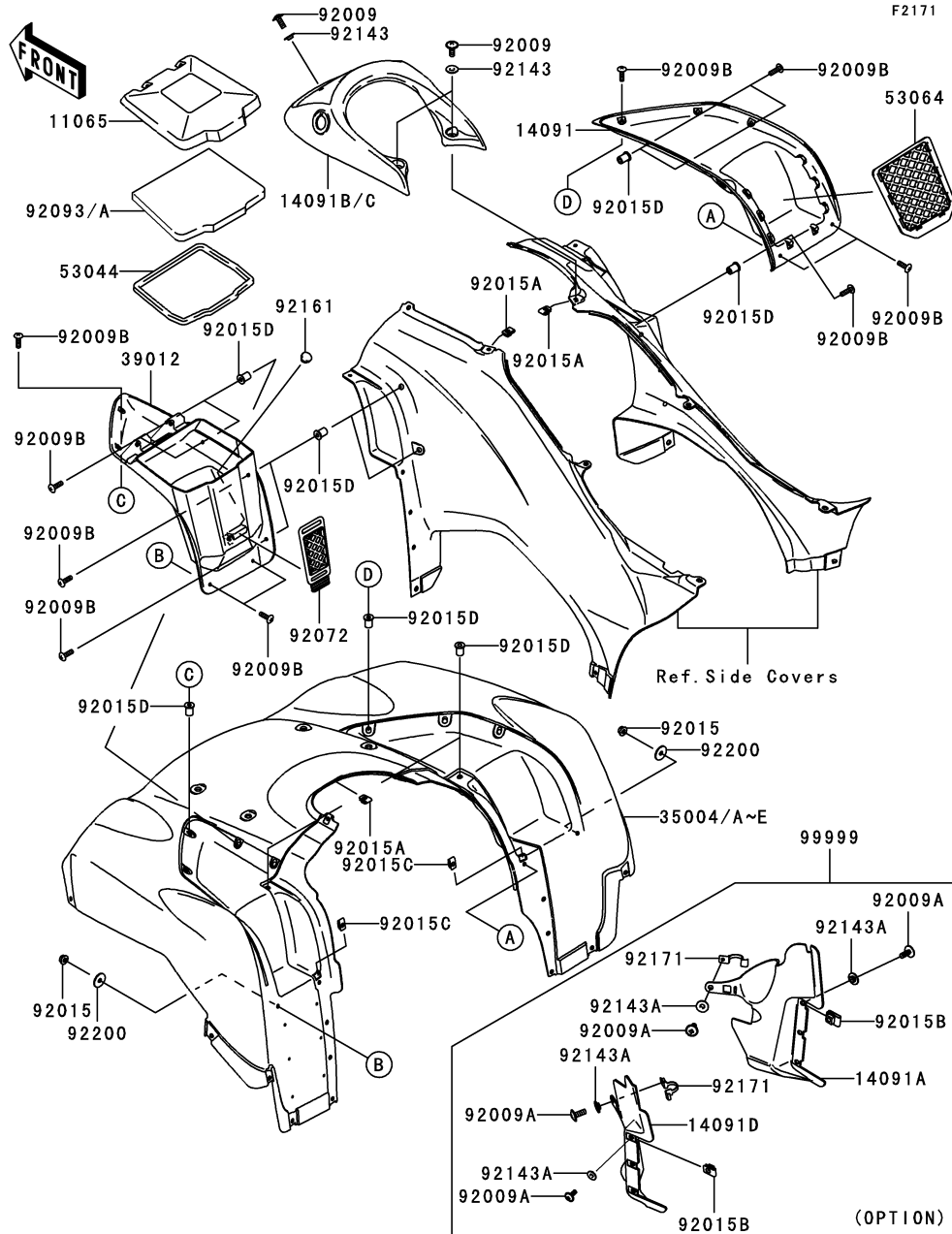

Ref. No.	Part No.	Description	Quantity-KVF750			
			Spec Code		'08	'09
			D8F	D9F		
39012	39012-0015-6Z	CASE-STORAGE,F,BLACK			1	1
53044	53044-0037	TRIM,L=700			1	1
53064	53064-0002	NET-CARGO			1	1
92009	92009-1621	SCREW,6X16			3	3
92009A	92009-1621 (OPTION)	SCREW,6X16			8	8
92009B	92009-1655	SCREW,5X18			17	17
92015	92015-1259	NUT,FLANGED,5MM			2	2
92015A	92015-1602	NUT,6MM			3	3
92015B	92015-1602 (OPTION)	NUT,6MM			6	6
92015C	92015-1710	NUT,5MM			2	2
92015D	92015-1757	NUT,WELL,5MM			15	15
92072	92072-0095	BAND,STORAGE			1	1
92093	92093-0118	SEAL,STORAGE CAP			1	
92093A	92093-0136	SEAL,STORAGE CAP				1
92143	92143-1087	COLLAR			3	3
92143A	92143-1087 (OPTION)	COLLAR			8	8
92161	92161-0586	DAMPER			1	1
92171	92171-0223 (OPTION)	CLAMP			2	2
92200	92200-0284	WASHER,5.5X20X1.2			2	2
99999	99999-0055 (OPTION)	INNER FENDER KIT			1	1

This catalog covers:

'08~'09 KVF750 D8F/D9F Chassis

GRID NO.

E-12

This grid covers:

Rear Fender(s)

F2172

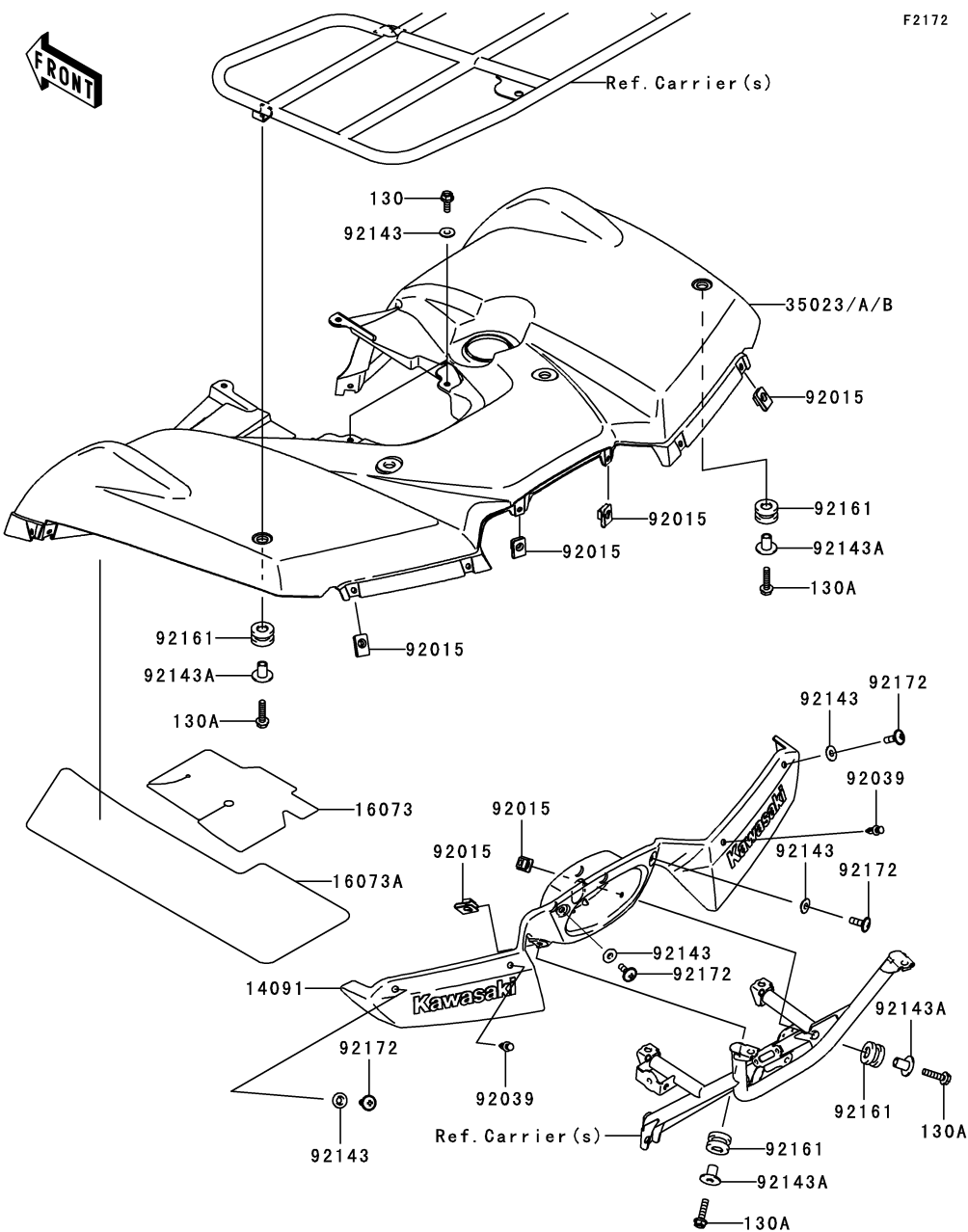

Ref. No.	Part No.	Description	Spec Code	Quantity-KVF750			
				'08	'09		
				D8F	D9F		
14091	14091-0252-6Z	COVER, TAIL LAMP, F. BLACK		1	1		
16073	16073-0031	INSULATOR, REAR FENDER, INNER		1	1		
16073A	16073-0032	INSULATOR, REAR FENDER, OUTER		1	1		
35023	35023-0050-286	FENDER-REAR, W. GREEN					
		L----- EU, UK		1	1		
35023A	35023-0050-290	FENDER-REAR, L. GREEN					
		L----- AS		1	1		
35023B	35023-0050-839	FENDER-REAR, BLACK					
		L----- EU, UK		1	1		
92015	92015-1602	NUT, 6MM		6	6		
92039	92039-1229	RIVET		2	2		
92143	92143-1087	COLLAR		6	6		
92143A	92143-1960	COLLAR		4	4		
92161	92161-0106	DAMPER		4	4		
92172	92172-0002	SCREW, 6X18		4	4		
130	130BB0616	BOLT-FLANGED, 6X16		2	2		
130A	130BB0625	BOLT-FLANGED, 6X25		4	4		

This catalog covers:

'08~'09 KVF750 D8F/D9F Chassis

GRID NO.

E-13

This grid covers:

Flap

F2173

Ref. No.	Part No.	Description	Spec Code	Quantity-KVF750			
				'08	'09		
				D8F	D9F		
11053	11053-1979	BRACKET,INNER FLAP,LH	1	1			
11053A	11053-1980	BRACKET,INNER FLAP,RH	1	1			
14091	14091-0491	COVER,FRONT FENDER,LH	1	1			
14091A	14091-0492	COVER,FRONT FENDER,RH	1	1			
16073	16073-0037	INSULATOR,INNER FLAP,LH,LWR	1	1			
16073A	16073-0038	INSULATOR,INNER FLAP,LH,UPP	1	1			
92039	92039-1260	RIVET	2	2			
92039A	92039-3763	RIVET,3.2X8	2	2			
92093	92093-0038	SEAL,FR FENDER	2	2			
92093A	92093-1580	SEAL	2	2			
92200	92200-1251	WASHER,3.5X8X1	2	2			

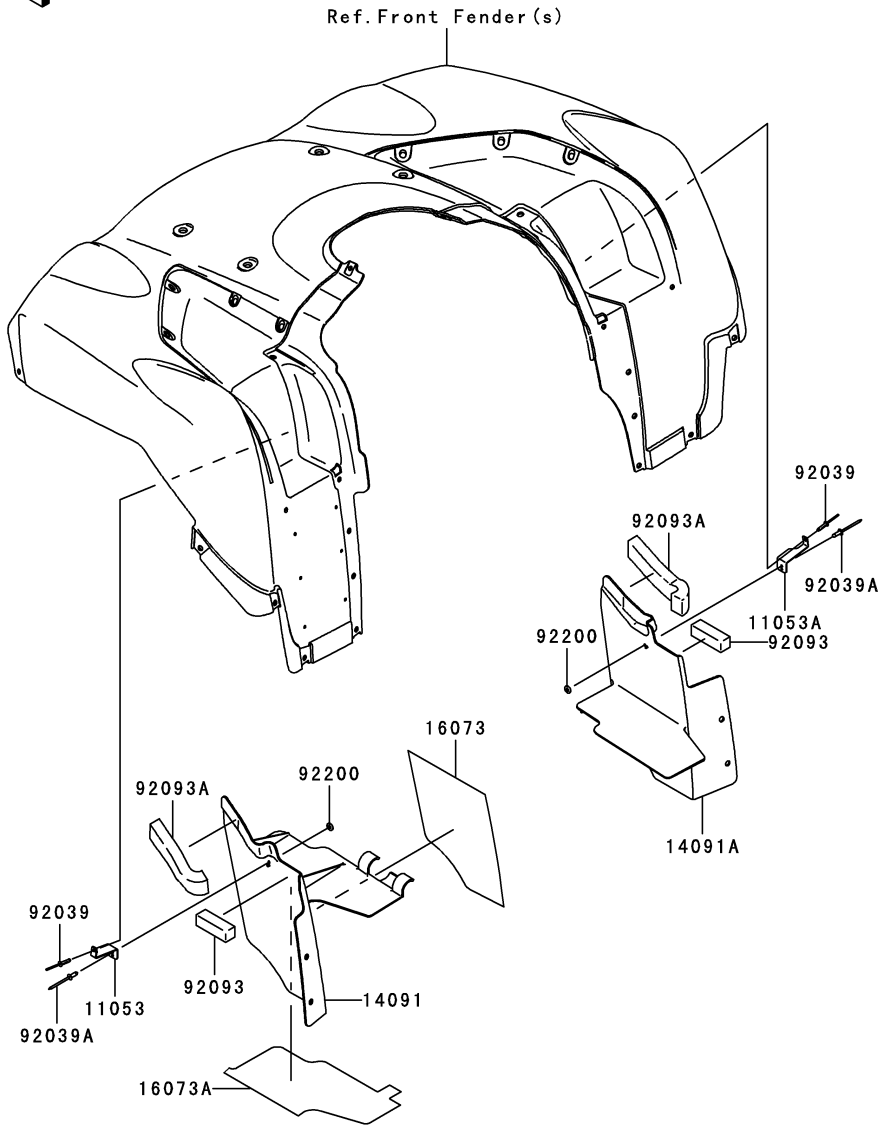

This catalog covers:

'08~'09 KVF750 D8F/D9F Chassis

GRID NO.

E-14

This grid covers:

Tires(D8F)

F2210

Ref. No.	Part No.	Description	Spec Code	Quantity-KVF750			
				'08	'09		
				D8F	D9F		
13271	13271-0976	PLATE,RIM			2		
16126	16126-4001	VALVE			4		
41009	41009-0039	TIRE,FR,AT25X8-12,KT191(D)			2		
41009A	41009-0112	TIRE,RR,AT25X10-12,KT195(D)			2		
41025	41025-0087	RIM,FR,12X6.0AT			2		
41025A	41025-0088	RIM,RR,12X7.5AT			2		
92200	92200-1595	WASHER,10.5X25X1.6			8		
92210	92210-1325	NUT,FLANGED,10MM			16		

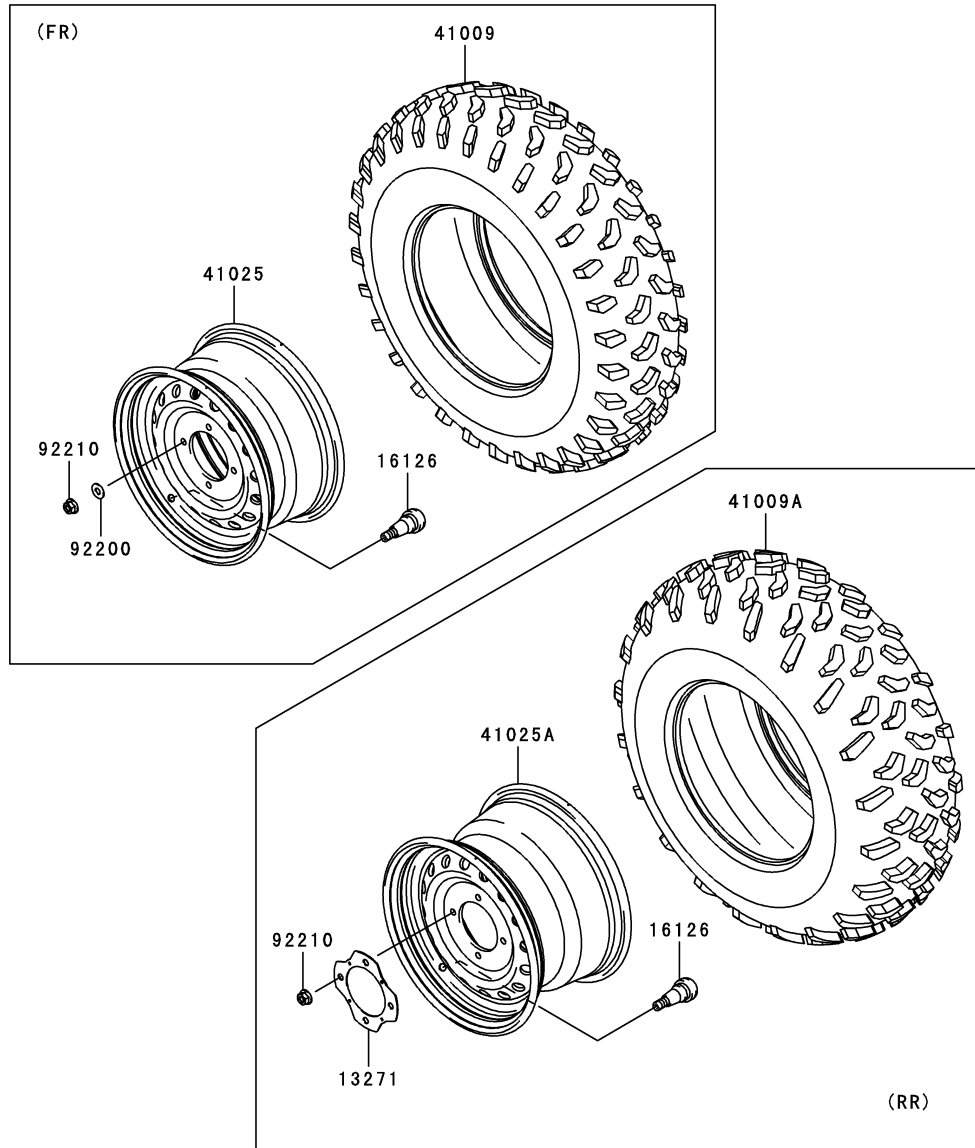

This catalog covers:

'08~'09 KVF750 D8F/D9F Chassis

GRID NO.

F-3

This grid covers:

Tires(D9F)

F2210A

Ref. No.	Part No.	Description	Spec Code	Quantity-KVF750			
				'08	'09		
				D8F	D9F		

16126	16126-4001	VALVE					4
41009	41009-0039	TIRE,FR,AT25X8-12,KT191(D)					2
41009A	41009-0112	TIRE,RR,AT25X10-12,KT195(D)					2
41025	41025-0087	RIM,FR,12X6.0AT					2
41025A	41025-0116	RIM,RR,12X7.5AT					2
92200	92200-1595	WASHER,10.5X25X1.6					8
92210	92210-1325	NUT,FLANGED,10MM					16

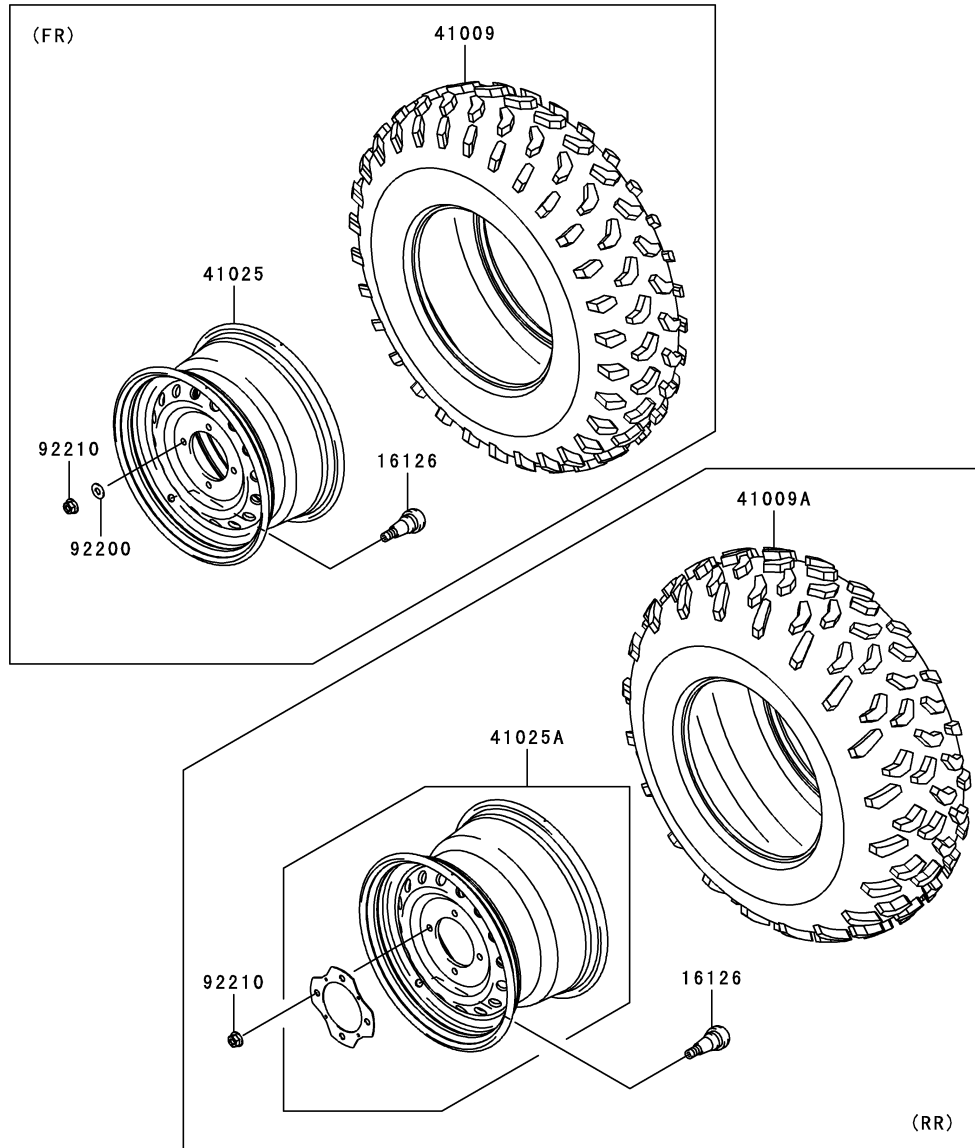

This catalog covers:

'08~'09 KVF750 D8F/D9F Chassis

GRID NO.

F-4

This grid covers:

Front Hub



F2230

Ref. No.	Part No.	Description	Spec Code	Quantity-KVF750			
				'08	'09		
				D8F	D9F		
11065	11065-1153	CAP,WHEEL		2	2		
49030	49030-0032	HUB,FR		2	2		
92151	92151-1392	BOLT,10X29.5		8	8		
92210	92210-1349	NUT,CASTLE,18MM		2	2		
550	550AA4025	PIN-COTTER,4.0X25		2	2		

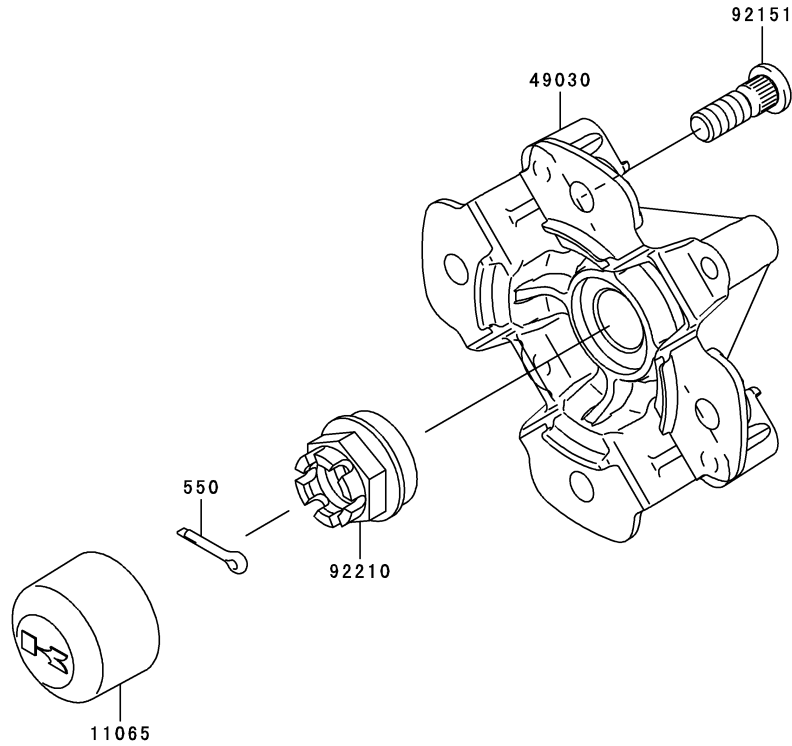

This catalog covers:

'08~'09 KVF750 D8F/D9F Chassis

GRID NO.

F-5

This grid covers:

Rear Hub



F2240

Ref. No.	Part No.	Description	Spec Code	Quantity-KVF750			
				'08	'09		
				D8F	D9F		
11065	11065-1153	CAP,WHEEL		2	2		
49030	49030-0034	HUB,RR		2	2		
92151	92151-1392	BOLT,10X29.5		8	8		
92210	92210-1381	NUT,CASTLE,20MM		2	2		
550	550AA4025	PIN-COTTER,4.0X25		2	2		

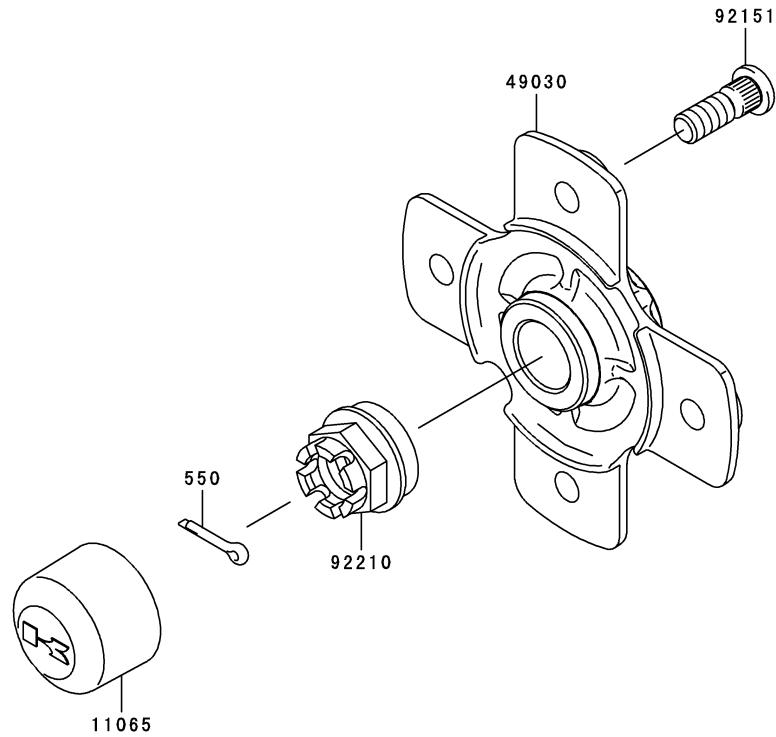

This catalog covers:

'08~'09 KVF750 D8F/D9F Chassis

GRID NO.

F-6

This grid covers:

Brake Pedal

F2260

Ref. No.	Part No.	Description	Spec Code	Quantity-KVF750			
				'08	'09		
				D8F	D9F		
11053	11053-0642	BRACKET,BRAKE CABLE	1	1			
27010	27010-1494	SWITCH,BRAKE	1	1			
41053	41053-0006	LEVER-BRAKE CAM	1	1			
41072	41072-007	NUT,6MM	1	1			
43001	43001-0092	LEVER-BRAKE,PEDAL	1	1			
92015	92015-1410	NUT,6MM	1	1			
92022	92022-1049	WASHER,15.5X24X1.6	1	1			
92022A	92022-1582	WASHER,8.5X16X1.2	1	1			
92043	92043-1013	PIN,8X16	1	1			
92145	92145-0144	SPRING,REAR BRAKE SWITCH	1	1			
92145A	92145-1313	SPRING,BRAKE LEVER RETURN	1	1			
92145B	92145-1421	SPRING,BRAKE PEDAL RETURN	1	1			
112	112AA0622	BOLT-UPSET,6X22	1	1			
130	130BB0820	BOLT-FLANGED,8X20	2	2			
132	132BA0640	BOLT-FLANGED-SMALL,6X40	1	1			
550	550AA2015	PIN-COTTER,2.0X15	1	1			
550A	550AA2022	PIN-COTTER,2.0X22	1	1			
670	670B2015	O RING,15MM	2	2			

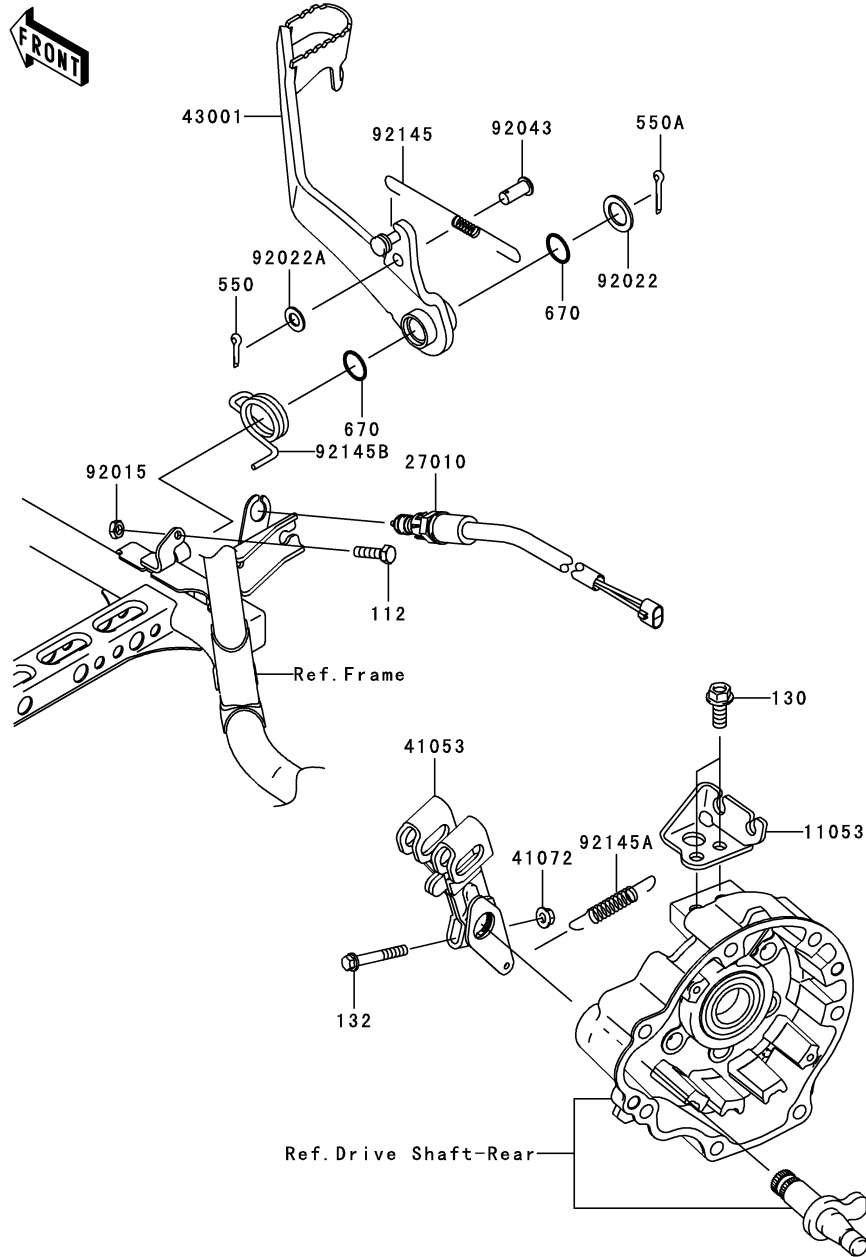

This catalog covers:

'08~'09 KVF750 D8F/D9F Chassis

GRID NO.

F-7

This grid covers:

Shock Absorber(s)

F2280

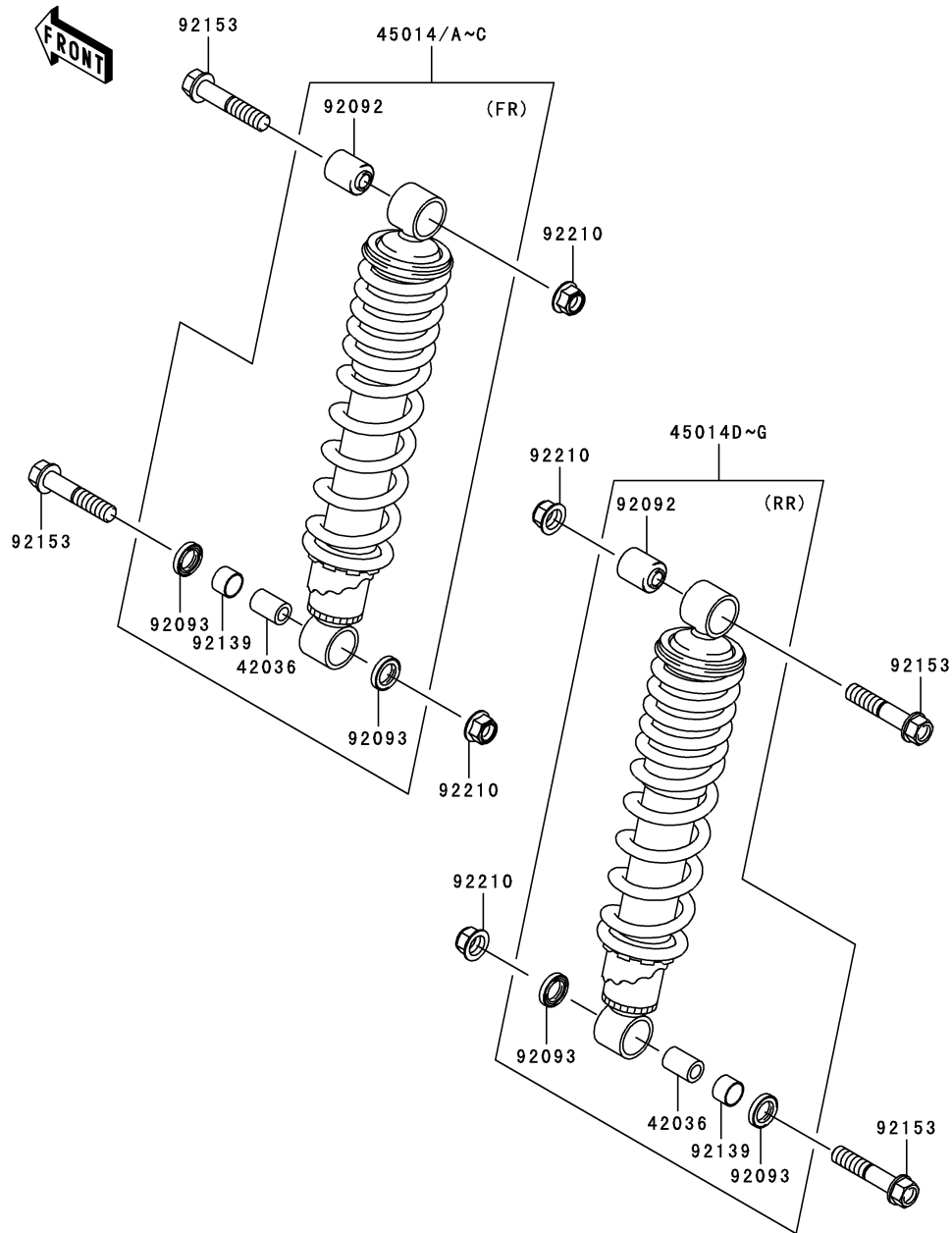

Ref. No.	Part No.	Description	Spec Code	Quantity-KVF750			
				'08	'09		
				D8F	D9F		
42036	42036-0018	SLEEVE		4	4		
45014	45014-0203-CD	SHOCKABSORBER,FR,F.RED					
		L----- EU,UK		2			
45014A	45014-0203-EH	SHOCKABSORBER,FR,P.WHITE					
		L----- AS		2	2		
45014B	45014-0203-VM	SHOCKABSORBER,FR,S.RED					
		L----- EU,UK		2			
45014C	45014-0203-17D	SHOCKABSORBER,FR,E COAT BLACK					
		L----- EU,UK		2			
45014D	45014-0204-CD	SHOCKABSORBER,RR,F.RED					
		L----- EU,UK		2			
45014E	45014-0204-EH	SHOCKABSORBER,RR,P.WHITE					
		L----- AS		2	2		
45014F	45014-0204-VM	SHOCKABSORBER,RR,S.RED					
		L----- EU,UK		2			
45014G	45014-0204-17D	SHOCKABSORBER,RR,E COAT BLACK					
		L----- EU,UK		2			
92092	92092-0007	BUSHING-RUBBER		4	4		
92093	92093-0033	SEAL		8	8		
92139	92139-0084	BUSHING		4	4		
92153	92153-1139	BOLT,FLANGED,10X50		8	8		
92210	92210-0276	NUT,LOCK,FLANGED,10MM		8	8		

This catalog covers:

'08~'09 KVF750 D8F/D9F Chassis

GRID NO.

F-8

This grid covers:

Front Master Cylinder

F2291

Ref. No.	Part No.	Description	Spec Code	Quantity-KVF750			
				'08	'09		
				D8F	D9F		
27010	27010-0025	SWITCH,BRAKE	1	1			
43015	43015-0036	CYLINDER-ASSY-MASTER,FR	1	1			
43020	43020-1054	PISTON-COMP-BRAKE,FR	1	1			
43022	43022-1010	STOPPER-BRAKE,PISTON	1	1			
43026	43026-1074	CAP-BRAKE	1	1			
43028	43028-1061	DIAPHRAGM	1	1			
43034	43034-1016	HOLDER-BRAKE,MASTER CYLINDER	1	1			
43095	43095-0078	HOSE-BRAKE,FR	1	1			
46092	46092-1208	LEVER-GRIP,FRONT BRAKE	1	1			
49006	49006-1040	BOOT,DUST	1	1			
49006A	49006-1338	BOOT,RH	1	1			
49016	49016-1044	COVER-SEAL,MASTER CYLINDER	1	1			
49091	49091-0001	WASHER-SEAL,10.1X14.5X1.5	6	6			
92001	92001-1728	BOLT,FRONT BRAKE LEVER	1	1			
92002	92002-1323	BOLT,SCREW,4X12	1	1			
92002A	92002-1894	BOLT	2	2			
92009	92009-1458	SCREW,4MM	2	2			
92015	92015-1233	NUT,FLANGED,6MM,BLACK	1	1			
92153	92153-0627	BOLT,OIL,L=23	3	3			
132	132BB0512	BOLT-FLANGED-SMALL,5X12	2	2			
132A	132BB0630	BOLT-FLANGED-SMALL,6X30	1	1			

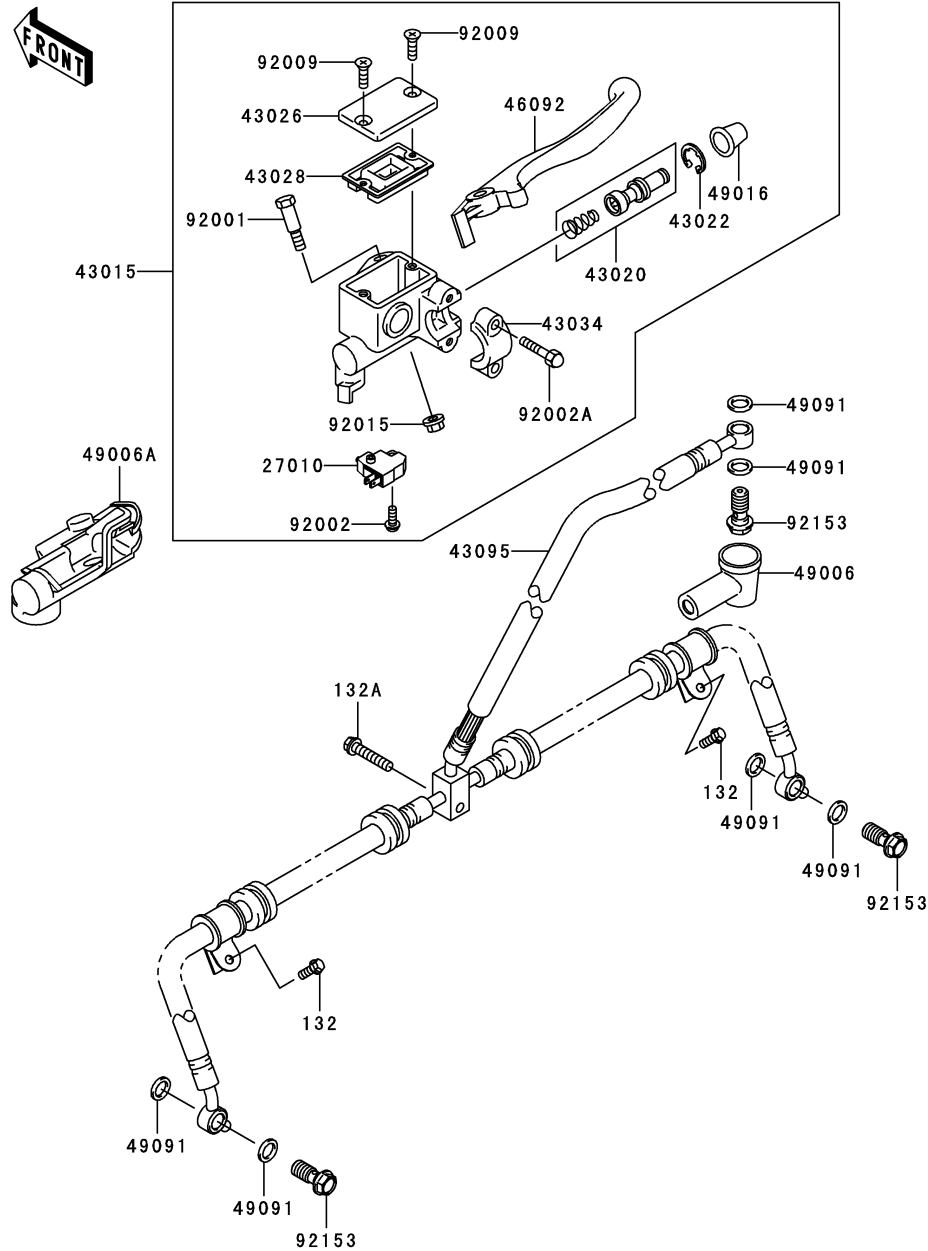

This catalog covers:

'08~'09 KVF750 D8F/D9F Chassis

GRID NO.

F-9

This grid covers:

Front Brake

F2292

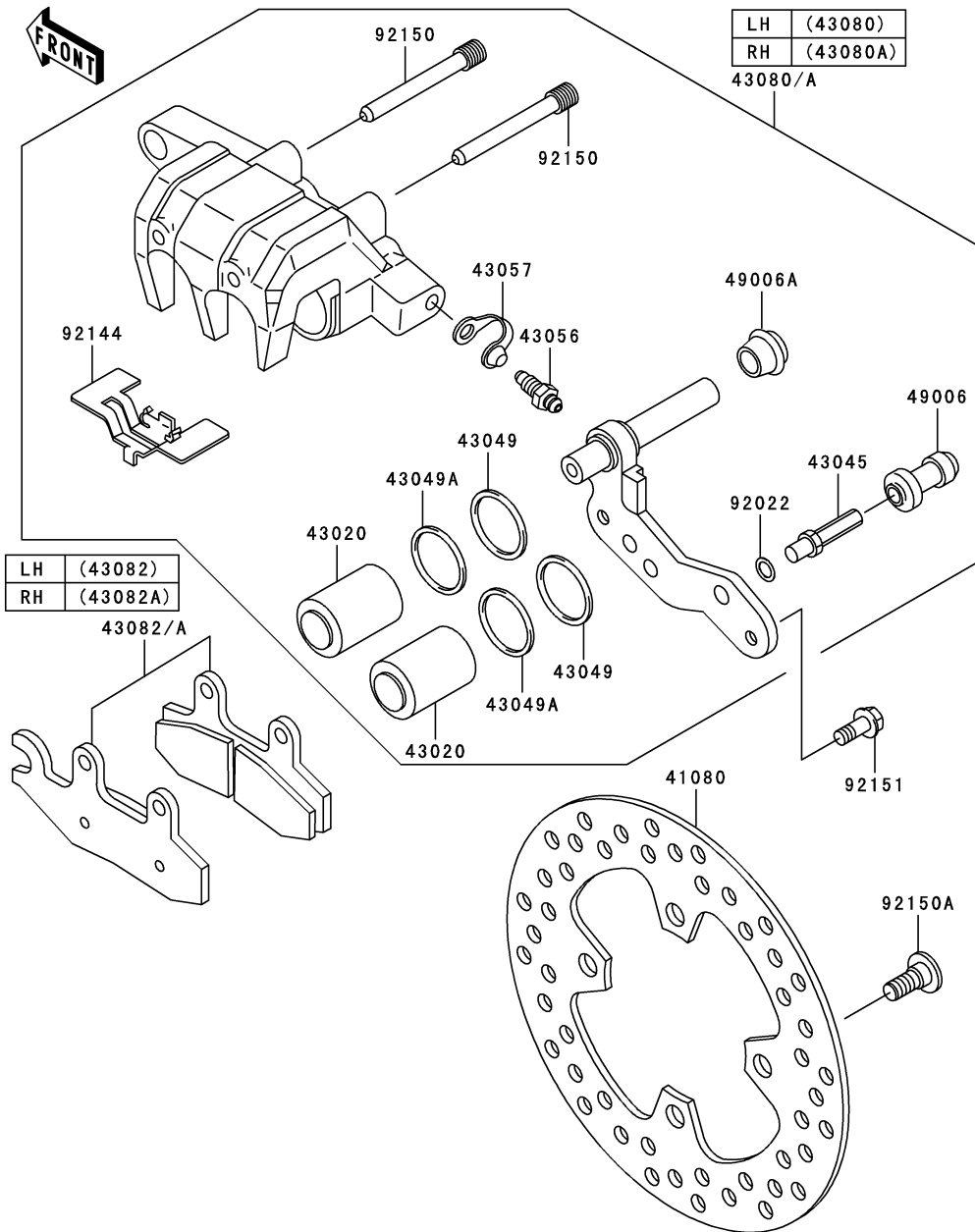

Ref. No.	Part No.	Description	Spec Code	Quantity-KVF750			
				'08	'09		
				D8F	D9F		

41080	41080-1513	DISC,FR		2	2		
43020	43020-1101	PISTON-COMP-BRAKE		4	4		
43045	43045-1010	SHAFT-CALIPER		2	2		
43049	43049-1063	PACKING		4	4		
43049A	43049-1064	PACKING		4	4		
43056	43056-1055	BREATHER		2	2		
43057	43057-1001	CAP-BREATHER		2	2		
43080	43080-0019-DJ	CALIPER-SUB-ASSY,FR,LH,BLACK		1	1		
43080A	43080-0020-DJ	CALIPER-SUB-ASSY,FR,RH,BLACK		1	1		
43082	43082-0022	PAD-ASSY-BRAKE,FR,LH		1	1		
43082A	43082-0023	PAD-ASSY-BRAKE,FR,RH		1	1		
49006	49006-1088	BOOT,CALIPER		2	2		
49006A	49006-1242	BOOT,CALIPER		2	2		
92022	92022-1373	WASHER,WAVE		2	2		
92144	92144-1319	SPRING,PAD		2	2		
92150	92150-1144	BOLT		4	4		
92150A	92150-1800	BOLT,SOCKET,8X20		8	8		
92151	92151-1793	BOLT,FLANGED,8X19		4	4		

This catalog covers:

'08~'09 KVF750 D8F/D9F Chassis

GRID NO.

F-10

This grid covers:

Handlebar(1/2)

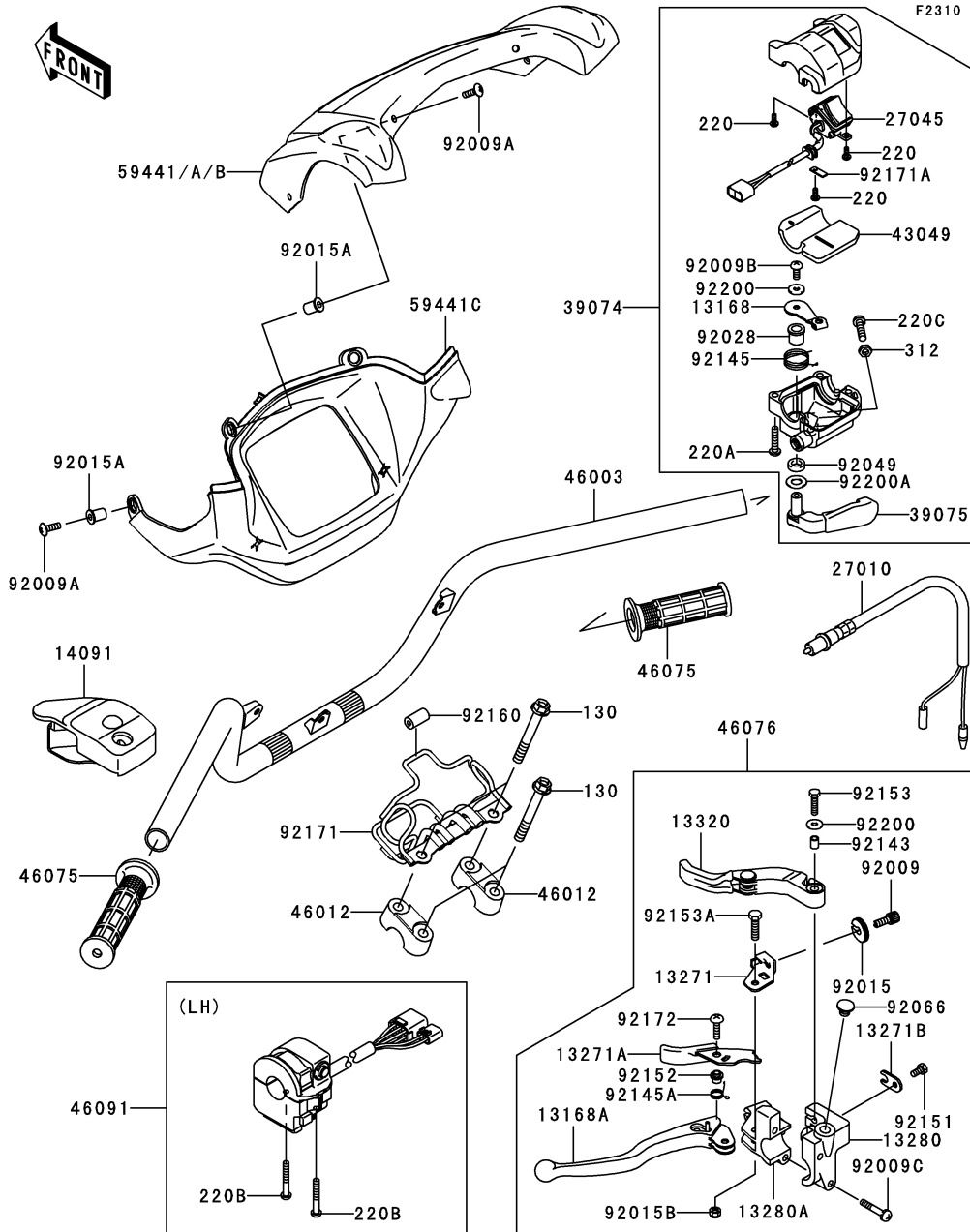

Ref. No.	Part No.	Description	Spec Code	Quantity-KVF750			
				'08	'09		
				D8F	D9F		
13168	13168-1715	LEVER	1	1			
13168A	13168-1736	LEVER,LH	1	1			
13271	13271-1259	PLATE,LOCK	1	1			
13271A	13271-1635	PLATE,LEVER LOCK	1	1			
13271B	13271-1636	PLATE,WIRE OUTER STOPPER	1	1			
13280	13280-1226	HOLDER,DIFF LOCK LEVER	1	1			
13280A	13280-1227	HOLDER,LEVER,LH	1	1			
13320	13320-1018	LEVER-ASSY,DEFF LOCK	1	1			
14091	14091-1403	COVER,DIFF LOCK LEVER	1	1			
27010	27010-1294	SWITCH,BRAKE	1	1			
27045	27045-0010	SWITCH-ASSY	1	1			
39074	39074-0002	LEVER-ASSY-THROTTLE	1	1			
39075	39075-1062	LEVER-THROTTLE	1	1			
43049	43049-1088	PACKING	1	1			
46003	46003-1580	HANDLE	1	1			
46012	46012-1168	HOLDER-HANDLE	2	2			
46075	46075-7501	GRIP,HANDLE	2	2			
46076	46076-1238	LEVER-ASSY-GRIP,DEFF LOCK	1	1			
46091	46091-0111	HOUSING-ASSY-CONTROL,LH	1	1			
59441	59441-0005-286	COVER-HANDLE,FR,W.GREEN	1	1			
		L----- EU,UK	1	1			
59441A	59441-0005-290	COVER-HANDLE,FR,L.GREEN					
		L----- AS	1	1			
59441B	59441-0005-839	COVER-HANDLE,FR,BLACK					
		L----- EU,UK	1	1			
59441C	59441-0006-6Z	COVER-HANDLE,RR,F.BLACK	1	1			
92009	92009-1435	SCREW,CABLE ADJUST,8MM	1	1			
92009A	92009-1654	SCREW,5X16,BLACK	4	4			
92009B	92009-1959	SCREW	1	1			
92009C	92009-1961	SCREW,6X30	2	2			
92015	92015-1596	NUT,CABLE ADJUST LOCK,8MM	1	1			
92015A	92015-1757	NUT,WELL,5MM	4	4			
92015B	92015-1829	NUT	1	1			
92028	92028-1986	BUSHING	1	1			
92049	92049-1578	SEAL-OIL	1	1			
92066	92066-1077	PLUG,9.5X8,POLYETHYLENE	1	1			
92143	92143-1216	COLLAR	1	1			
92145	92145-1392	SPRING	1	1			
92145A	92145-1429	SPRING	1	1			
92151	92151-1975	BOLT,5X10	1	1			

This catalog covers:

'08~'09 KVF750 D8F/D9F Chassis

GRID NO.

F-11

This grid covers:

Handlebar(2/2)

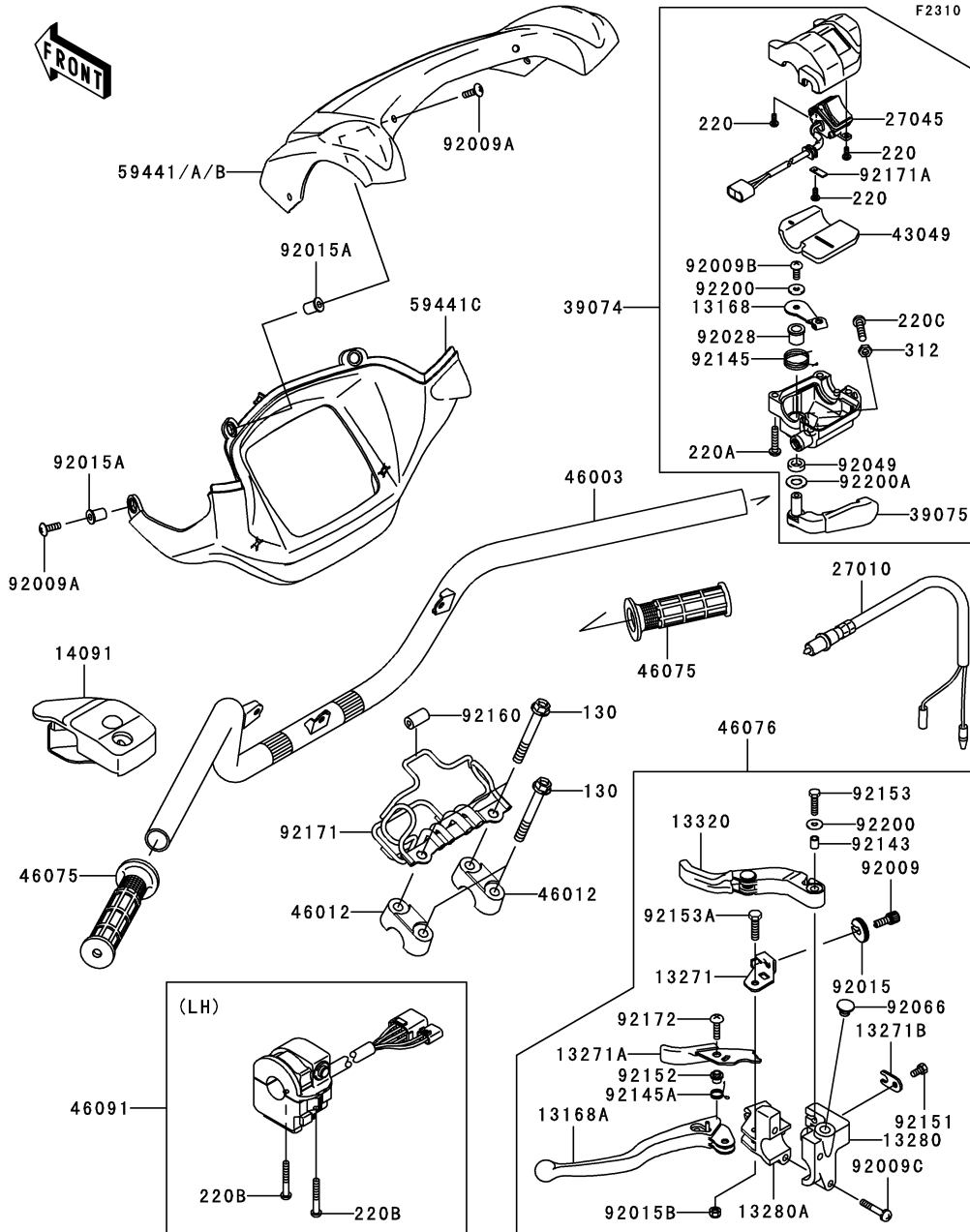

Ref. No.	Part No.	Description	Spec Code	Quantity-KVF750			
				'08	'09		
				D8F	D9F		
92152	92152-1176	COLLAR	1	1			
92153	92153-1129	BOLT,5X20	1	1			
92153A	92153-1919	BOLT	1	1			
92160	92160-1074	DAMPER,4.5X11X20	1	1			
92171	92171-0378	CLAMP,BREATHER TUBE	1	1			
92171A	92171-1344	CLAMP	1	1			
92172	92172-0078	SCREW,5X20	1	1			
92200	92200-1558	WASHER	2	2			
92200A	92200-1559	WASHER	1	1			
130	130CA0860	BOLT-FLANGED,8X60	4	4			
220	220AA0308	SCREW-PAN-CROS,3X8	3	3			
220A	220AB0525	SCREW-PAN-CROS,5X25	3	3			
220B	220AB0535	SCREW-PAN-CROSS,5X35	2	2			
220C	220AB0625	SCREW-PAN-CROS,6X25	1	1			
312	312AB0600	NUT-HEX,6MM,BLACK	1	1			

This catalog covers:

'08~'09 KVF750 D8F/D9F Chassis

GRID NO.

F-12

This grid covers:

Fuel Tank

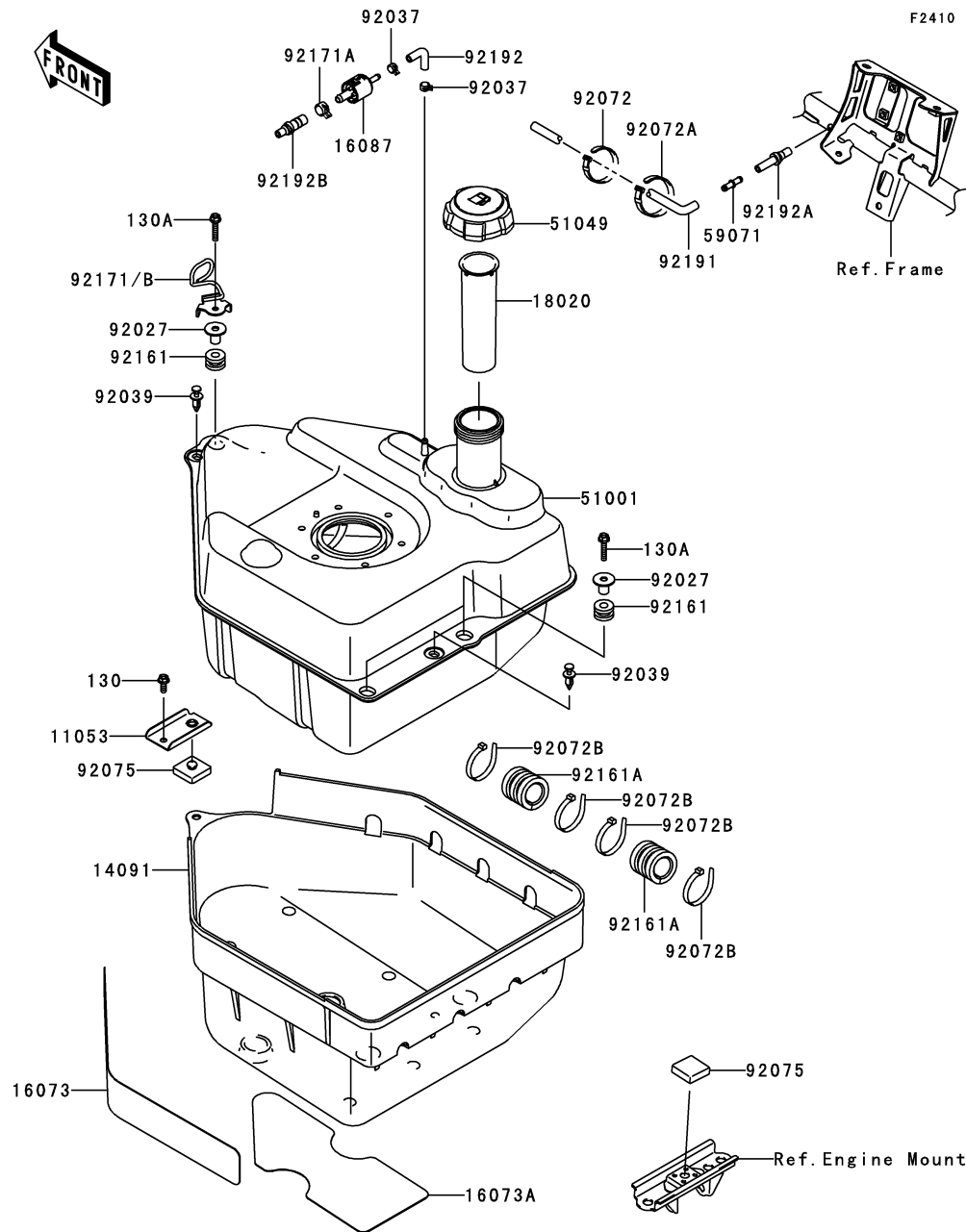

Ref. No.	Part No.	Description	Spec Code	Quantity-KVF750			
				'08	'09		
				D8F	D9F		
11053	11053-0936	BRACKET,FUEL TANK, TOP	1	1			
14091	14091-0608	COVER,FUEL TANK,LWR	1	1			
16073	16073-0033	INSULATOR,FUEL TANK COVER,SIDE	1	1			
16073A	16073-0034	INSULATOR,FUEL TANK COVER,LWR	1	1			
16087	16087-0002	VALVE-CHECK	1	1			
18020	18020-0008	BAFFLE,FUEL TANK	1	1			
51001	51001-0237	TANK-COMP-FUEL	1	1			
51049	51049-1128	CAP-TANK,FUEL	1	1			
59071	59071-3717	JOINT	1	1			
92027	92027-1847	COLLAR,L=16.1	3	3			
92037	92037-1461	CLAMP,TUBE	2	2			
92039	92039-1229	RIVET	2	2			
92072	92072-031	BAND,L=149	1	1			
92072A	92072-056	BAND,L=186	1	1			
92072B	92072-1239	BAND,L=188	4	4			
92075	92075-1882	DAMPER	2	2			
92161	92161-0106	DAMPER	3	3			
92161A	92161-1111	DAMPER,FUEL TANK,RR	2	2			
92171	92171-0380	CLAMP,FUEL TUBE	1				
92171A	92171-0515	CLAMP	1	1			
92171B	92171-1741	CLAMP,FUEL TUBE		1			
92191	92191-1384	TUBE,CANISTER-SEPARATOR,BLUE	1	1			
92192	92192-0067	TUBE,FUEL TANK-CHECK VALVE	1	1			
92192A	92192-0068	TUBE,FRAME PIPE-CHECK VALVE	1	1			
92192B	92192-0128	TUBE,FRAME PIPE-CHECK VALVE	1	1			
130	130BA0616	BOLT-FLANGED,6X16	1	1			
130A	130BA0630	BOLT-FLANGED,6X30	3	3			

This catalog covers:

'08~'09 KVF750 D8F/D9F Chassis

GRID NO.

F-13

This grid covers:

Seat

F2510

Ref. No.	Part No.	Description	Spec Code	Quantity-KVF750			
				'08	'09		
53066	53066-0196-MA	SEAT-ASSY,BLACK					
92145	92145-0022	SPRING,SEAT LATCH					

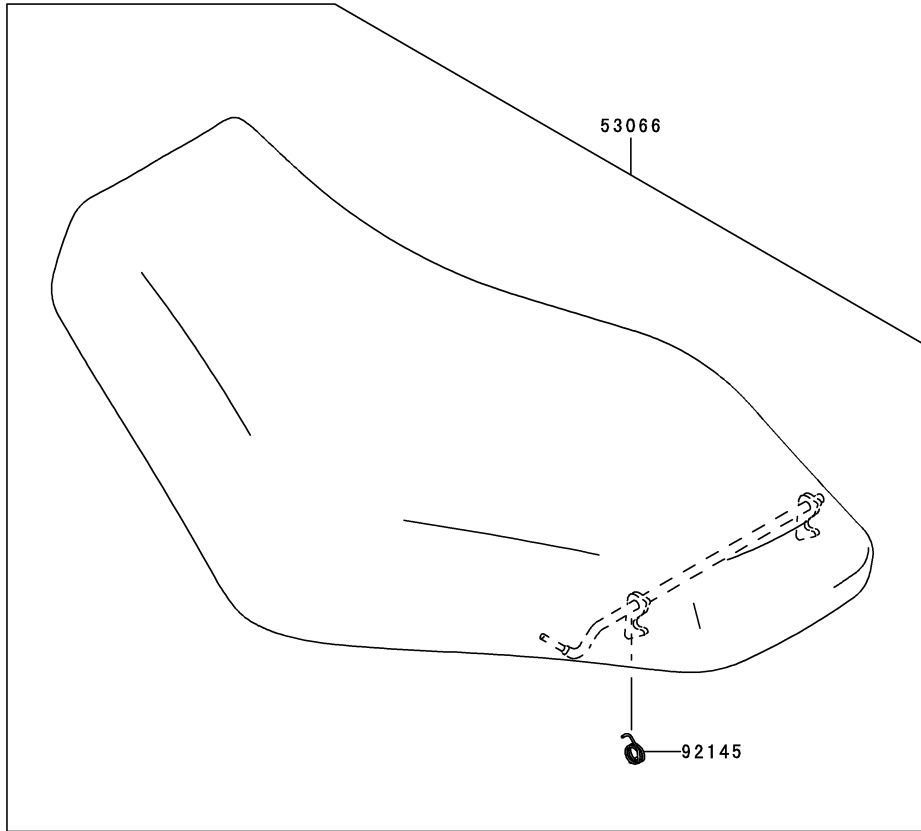

This catalog covers:

'08~'09 KVF750 D8F/D9F Chassis

GRID NO.

F-14

This grid covers:

Carrier(s)

F2520

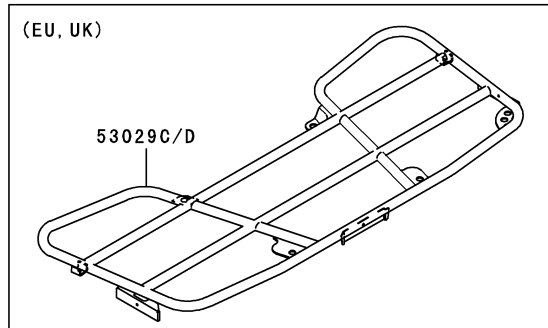
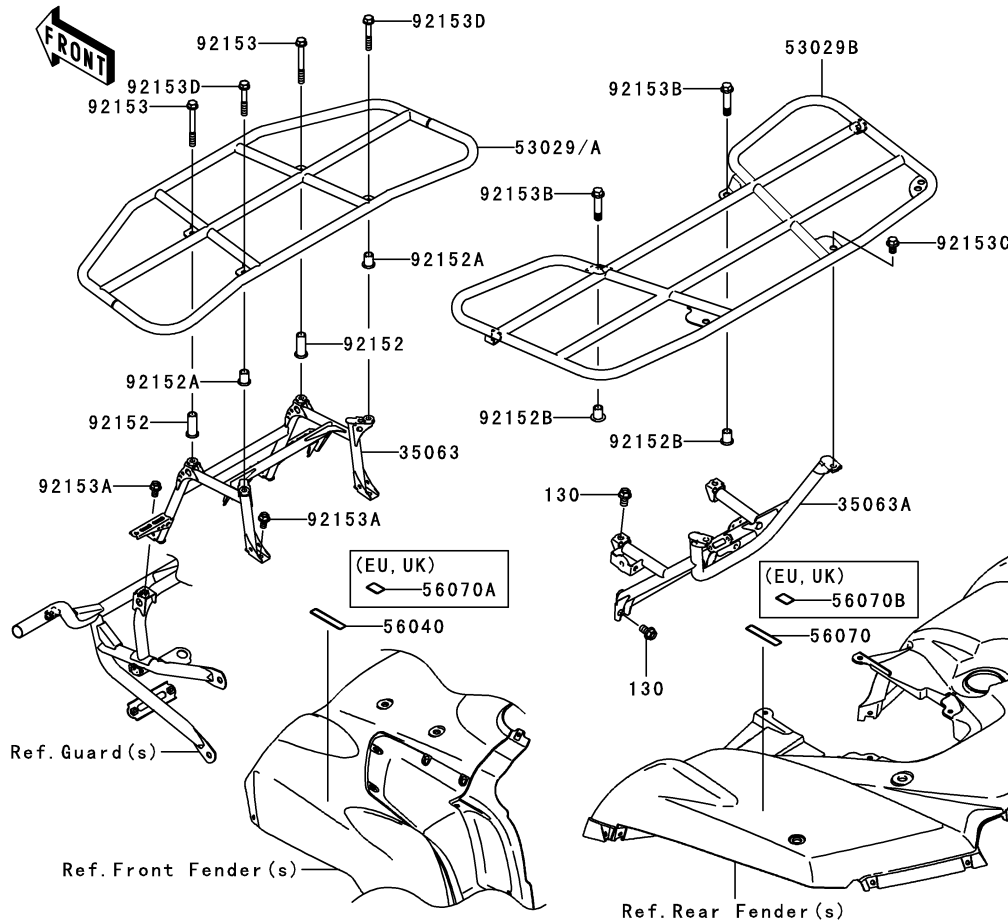

Ref. No.	Part No.	Description	Spec Code	Quantity-KVF750			
				'08	'09		
				D8F	D9F		
35063	35063-0164	STAY,FR		1	1		
35063A	35063-0501-388	STAY,REAR CARRIER,W.BLACK		1	1		
53029	53029-0054-16I	CARRIER,FR,RED					
		L-----	EU,UK	1	1		
53029A	53029-0054-388	CARRIER,FR,W.BLACK		1	1		
53029B	53029-0055-388	CARRIER,RR,W.BLACK					
		L-----	AS	1	1		
53029C	53029-0057-16I	CARRIER,RR,RED					
		L-----	EU,UK	1	1		
53029D	53029-0057-388	CARRIER,RR,W.BLACK					
		L-----	EU,UK	1	1		
56040	56040-132I	LABEL-WARNING,MAXIMUM LOAD					
		L-----	AS	1	1		
56070	56070-004I	LABEL-WARNING,MAXIMUM LOAD					
		L-----	AS	1	1		
56070A	56070-1103	LABEL-WARNING,CARRIER LOAD,FR					
		L-----	EU,UK	1	1		
56070B	56070-1253	LABEL-WARNING,MAXIMUM LOAD					
		L-----	EU,UK	1	1		
92152	92152-0254	COLLAR		2	2		
92152A	92152-0255	COLLAR		2	2		
92152B	92152-0257	COLLAR		2	2		
92153	92153-0748	BOLT,FLANGED,8X70		2	2		
92153A	92153-093I	BOLT,FLANGED,8X14		4	4		
92153B	92153-1374	BOLT,FLANGED,10X44		2	2		
92153C	92153-1375	BOLT,FLANGED,10X14		2	2		
92153D	92153-1755	BOLT,FLANGED,8X50		2	2		
130	130CB1016	BOLT-FLANGED,10X16		4	4		

This catalog covers:

'08~'09 KVF750 D8F/D9F Chassis

GRID NO.

G-3

This grid covers:

Meter(s)



F2530

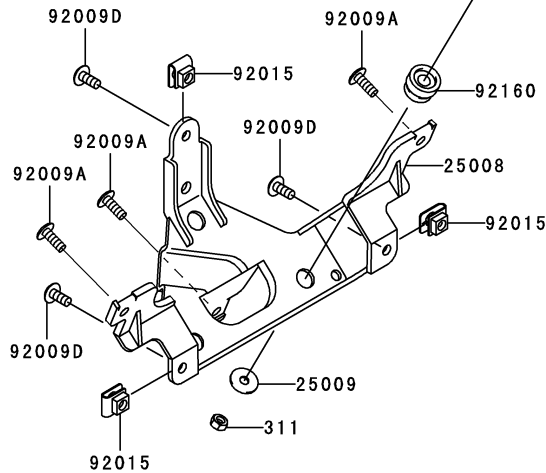
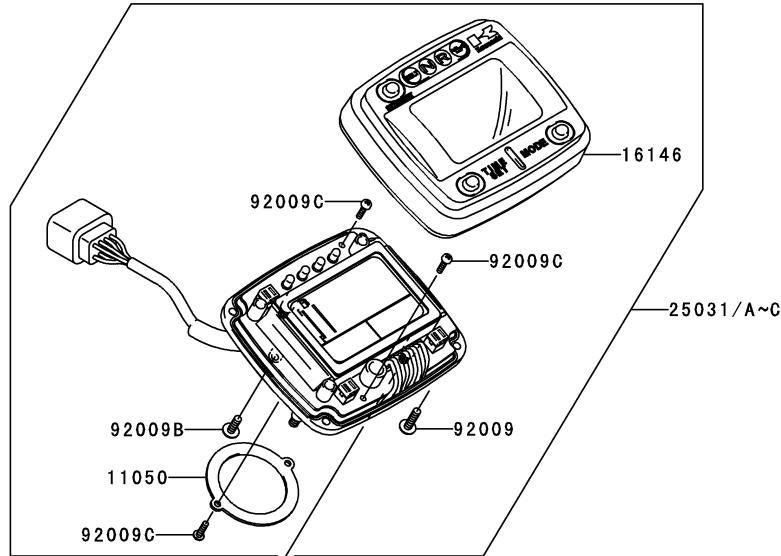
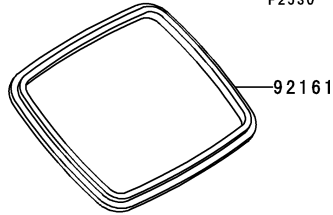

Ref. No.	Part No.	Description	Spec Code	Quantity-KVF750			
				'08	'09		
				D8F	D9F		
11050	11050-1932	BRACKET,METER		1		1	
16146	16146-0011	COVER-ASSY,UPPER		1		1	
25008	25008-0003	BRACKET-METER		1		1	
25009	25009-004	WASHER,5.2X16X1.2		3		3	
25031	25031-0163	METER-ASSY,MPH					
		L-----			UK		1
25031A	25031-0164	METER-ASSY,KPH					
		L-----			AS,EU		1
25031B	25031-0226	METER-ASSY,KPH					
		L-----			AS,EU		1
25031C	25031-0227	METER-ASSY,MPH					
		L-----			UK		1
92009	92009-1163	SCREW,TAPPING,4X16		4		4	
92009A	92009-1197	SCREW,TAPPING,5X14		3		3	
92009B	92009-1254	SCREW,TAPPING,4X12		1		1	
92009C	92009-1326	SCREW,3X12		4		4	
92009D	92009-1652	SCREW,5X12		3		3	
92015	92015-1573	NUT,5MM		3		3	
92160	92160-1460	DAMPER		3		3	
92161	92161-1114	DAMPER,METER,UPP		1		1	
311	311AB0500	NUT-HEX		3		3	

This catalog covers:

'08~'09 KVF750 D8F/D9F Chassis

GRID NO.

G-4

This grid covers:

Cables

F2540

Ref. No.	Part No.	Description	Quantity-KVF750			
			'08	'09		
			D8F	D9F		
54005	54005-0017	CABLE-BRAKE,PARKING	1	1		
54005A	54005-0018	CABLE-BRAKE,FOOT	1	1		
54010	54010-0064	CABLE,FRONT DIFF LOCK	1	1		
54012	54012-0207	CABLE-THROTTLE	1	1		
92072	92072-030	BAND,L=123	1	1		
92072A	92072-1239	BAND,L=188	3	3		
92171	92171-0228	CLAMPBRAKE CABLE	1	1		
482	482EA8000	CIRCLIP-TYPE-E,8MM	1	1		

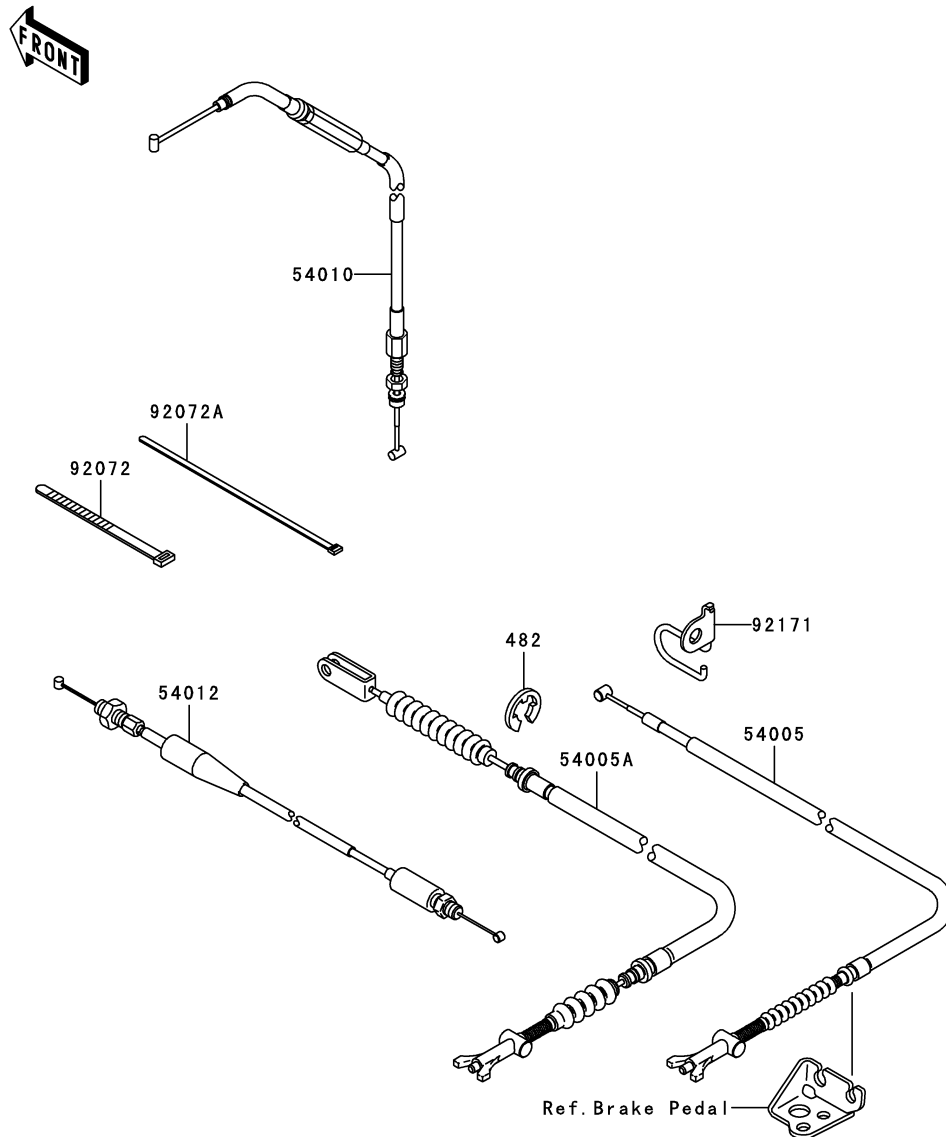

This catalog covers:

'08~'09 KVF750 D8F/D9F Chassis

GRID NO.

G-5

This grid covers:

Side Covers

F2611

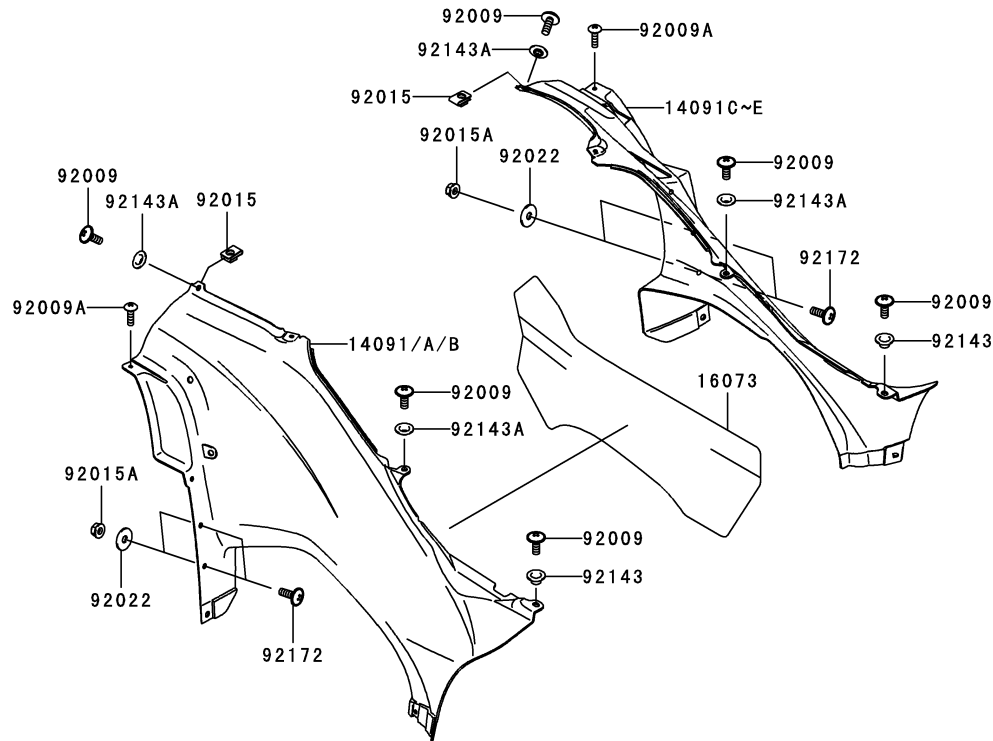

Ref. No.	Part No.	Description	Spec Code	Quantity-KVF750			
				'08	'09	D8F	D9F
14091	14091-0137-286	COVER,SIDE,LH,W.GREEN					
	L-----		EU,UK	1	1		
14091A	14091-0137-290	COVER,SIDE,LH,L.GREEN					
	L-----		AS	1	1		
14091B	14091-0137-839	COVER,SIDE,LH,BLACK					
	L-----		EU,UK	1	1		
14091C	14091-0138-286	COVER,SIDE,RH,W.GREEN					
	L-----		EU,UK	1	1		
14091D	14091-0138-290	COVER,SIDE,RH,L.GREEN					
	L-----		AS	1	1		
14091E	14091-0138-839	COVER,SIDE,RH,BLACK					
	L-----		EU,UK	1	1		
16073	16073-0030	INSULATOR,SIDE COVER					
				1	1		
92009	92009-1621	SCREW,6X16					
				6	6		
92009A	92009-1655	SCREW,5X18					
				2	2		
92015	92015-1602	NUT,6MM					
				2	2		
92015A	92015-1603	NUT,LOCK,FLANGED,6MM					
				4	4		
92022	92022-1346	WASHER,6.5X20X1.6,BLACK					
				4	4		
92143	92143-1057	COLLAR					
				2	2		
92143A	92143-1087	COLLAR					
				4	4		
92172	92172-0002	SCREW,6X18					
				4	4		

This catalog covers:

'08~'09 KVF750 D8F/D9F Chassis

GRID NO.

G-6

This grid covers:

Guard(s)

F2680

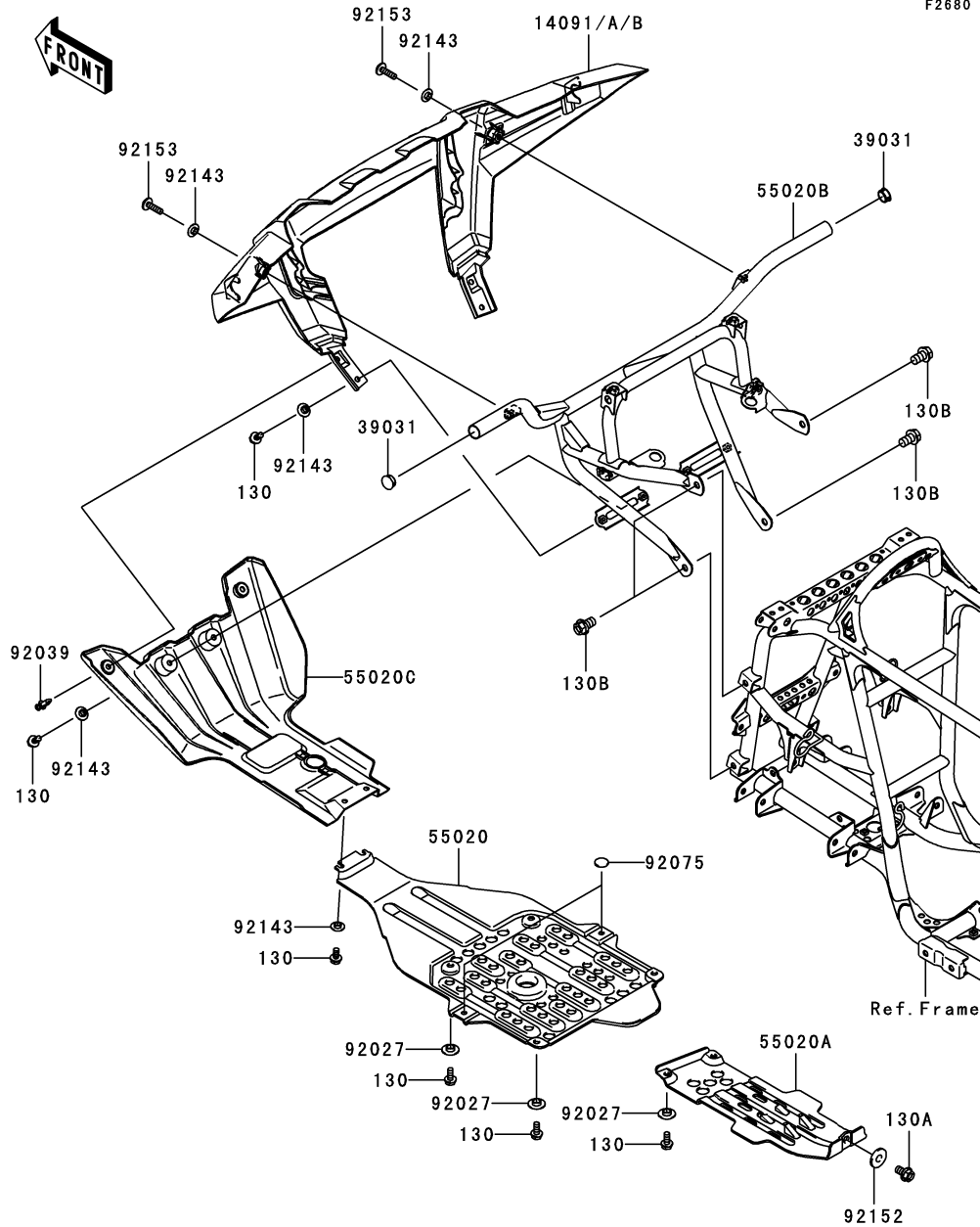

Ref. No.	Part No.	Description	Spec Code	Quantity-KVF750			
				'08	'09		
				D8F	D9F		
14091	14091-0961-286	COVER,FRONT BUMPER,W.GREEN					
		----- L -----	EU,UK	1	1		
14091A	14091-0961-290	COVER,FRONT BUMPER,L.GREEN					
		----- L -----	AS	1	1		
14091B	14091-0961-6Z	COVER,FRONT BUMPER,F.BLACK					
		----- L -----	EU,UK	1	1		
39031	39031-0011	CAP-END					
55020	55020-0065	GUARD,ENGINE					
				1	1		
55020A	55020-0105	GUARD,REAR GEAR BOX					
55020B	55020-0392	GUARD,FR					
55020C	55020-0426-6Z	GUARD,FRONT SKID,F.BLACK					
92027	92027-1964	COLLAR,L=4.7					
92039	92039-1229	RIVET					
				2	2		
92075	92075-261	DAMPER,RUBBER					
92143	92143-1087	COLLAR					
				8	8		
92152	92152-0198	COLLAR					
92153	92153-0574	BOLT,SOCKET,6X22					
				2	2		
130	130BB0614	BOLT-FLANGED,6X14					
				12	12		
130A	130BB0814	BOLT-FLANGED,8X14					
130B	130BB1016	BOLT-FLANGED,10X16					
				1	1		
				4	4		

This catalog covers:

'08~'09 KVF750 D8F/D9F Chassis

GRID NO.

G-7

This grid covers:

Headlight(s)

F2710

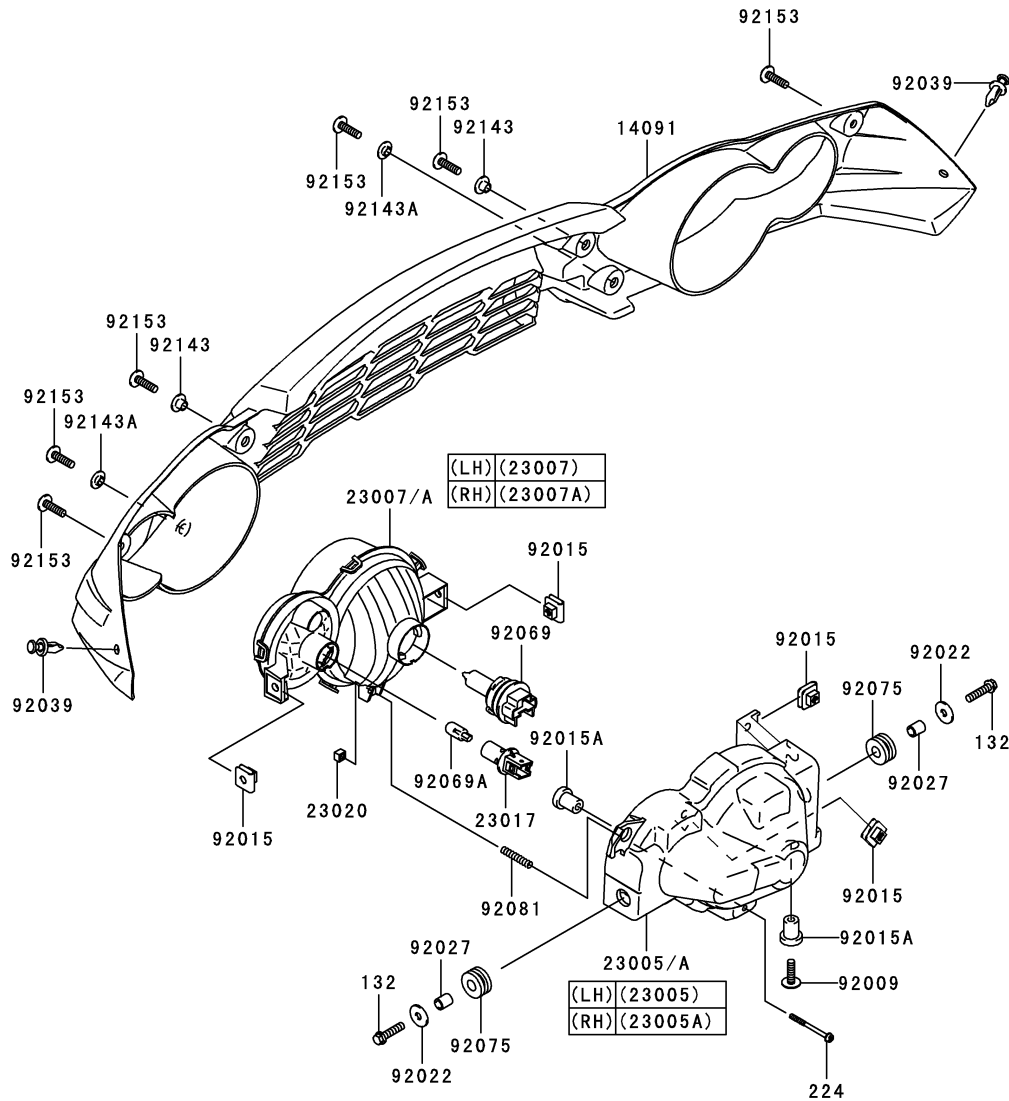

Ref. No.	Part No.	Description	Quantity-KVF750			
			'08	'09		
			D8F	D9F		
14091	14091-0736-6Z	COVER,HEAD LAMP,F.BLACK	1	1		
23005	23005-0006	BODY-COMP-HEAD LAMP,LH	1	1		
23005A	23005-0007	BODY-COMP-HEAD LAMP,RH	1	1		
23007	23007-0024	LENS-COMP,HEAD LAMP,LH	1	1		
23007A	23007-0025	LENS-COMP,HEAD LAMP,RH	1	1		
23017	23017-0001	SOCKET,HEAD LAMP	2	2		
23020	23020-018	NUT,4MM,FOCUS ADJUST	2	2		
92009	92009-1664	SCREW,6X22	2	2		
92015	92015-1094	NUT,6MM	8	8		
92015A	92015-1692	NUT,RUBBER,6MM	4	4		
92022	92022-125	WASHER,6.5X20X1.6	4	4		
92027	92027-162	COLLAR,6.8X10X12	4	4		
92039	92039-1229	RIVET	2	2		
92069	92069-0005	BULB,12V 40/40W	2	2		
92069A	92069-0006	BULB,12V 5W	2	2		
92075	92075-1690	DAMPER	4	4		
92081	92081-1896	SPRING,FOCUS ADJUST	2	2		
92143	92143-1057	COLLAR	2	2		
92143A	92143-1087	COLLAR	2	2		
92153	92153-0574	BOLT,SOCKET,6X22	6	6		
132	132BA0625	BOLT-FLANGED-SMALL,6X25	4	4		
224	224AA0445	SCREW-PAN-WP-CROS,4X45	2	2		

This catalog covers:

'08~'09 KVF750 D8F/D9F Chassis

GRID NO.

G-8

This grid covers:

Taillight(s)

F2720

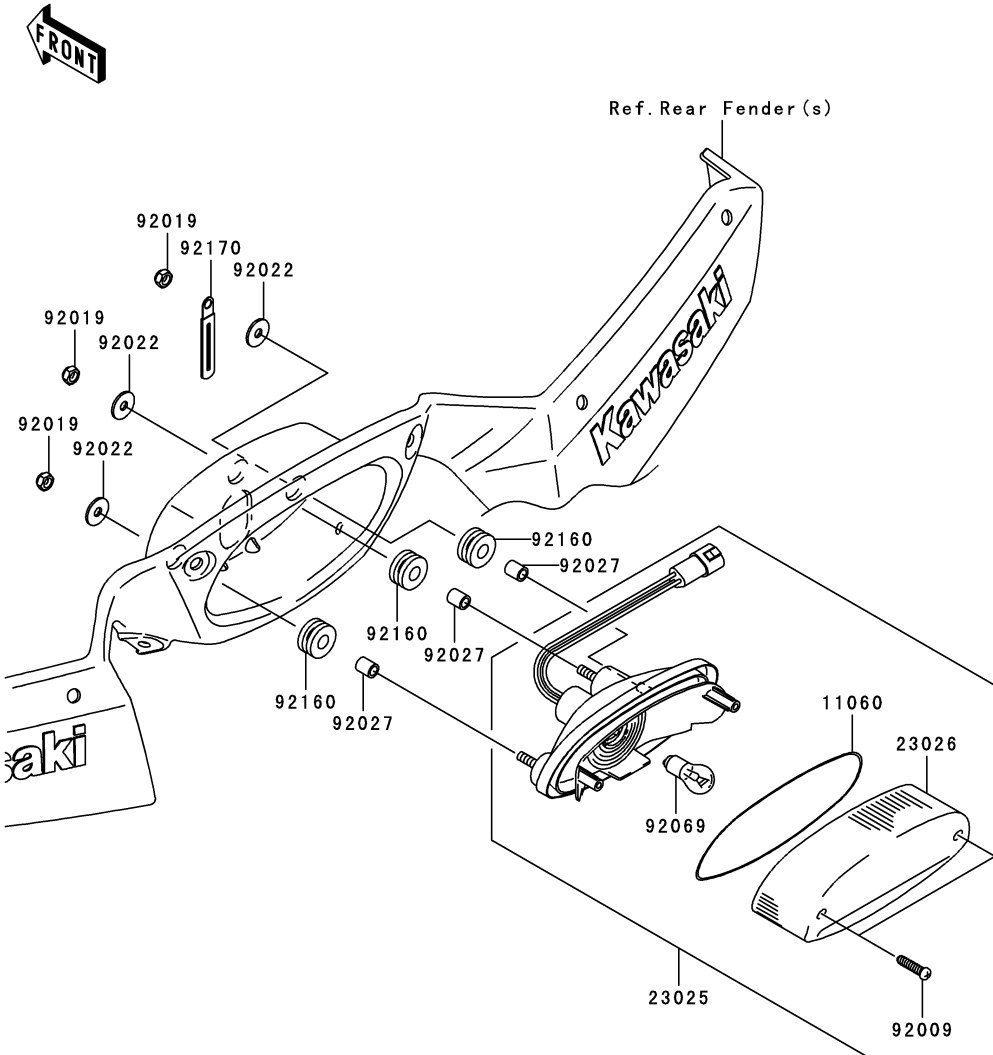

Ref. No.	Part No.	Description	Spec Code	Quantity-KVF750			
				'08	'09		
				D8F	D9F		
11060	11060-1174	GASKET, TAIL LAMP LENS	1	1			
23025	23025-0011	LAMP-TAIL	1	1			
23026	23026-1183	LENS, TAIL LAMP	1	1			
92009	92009-1378	SCREW, TAPPING, 4X20	2	2			
92019	92019-008	NUT, LOCK, 6MM	3	3			
92022	92022-1557	WASHER, 6.5X20X1.6	3	3			
92027	92027-162	COLLAR, 6.8X10X12	3	3			
92069	92069-063	BULB, 12V 21/5W	1	1			
92160	92160-1162	DAMPER	3	3			
92170	92170-1514	CLAMP	1	1			

This catalog covers:

'08~'09 KVF750 D8F/D9F Chassis

GRID NO.

G-9

This grid covers:

Chassis Electrical Equipment

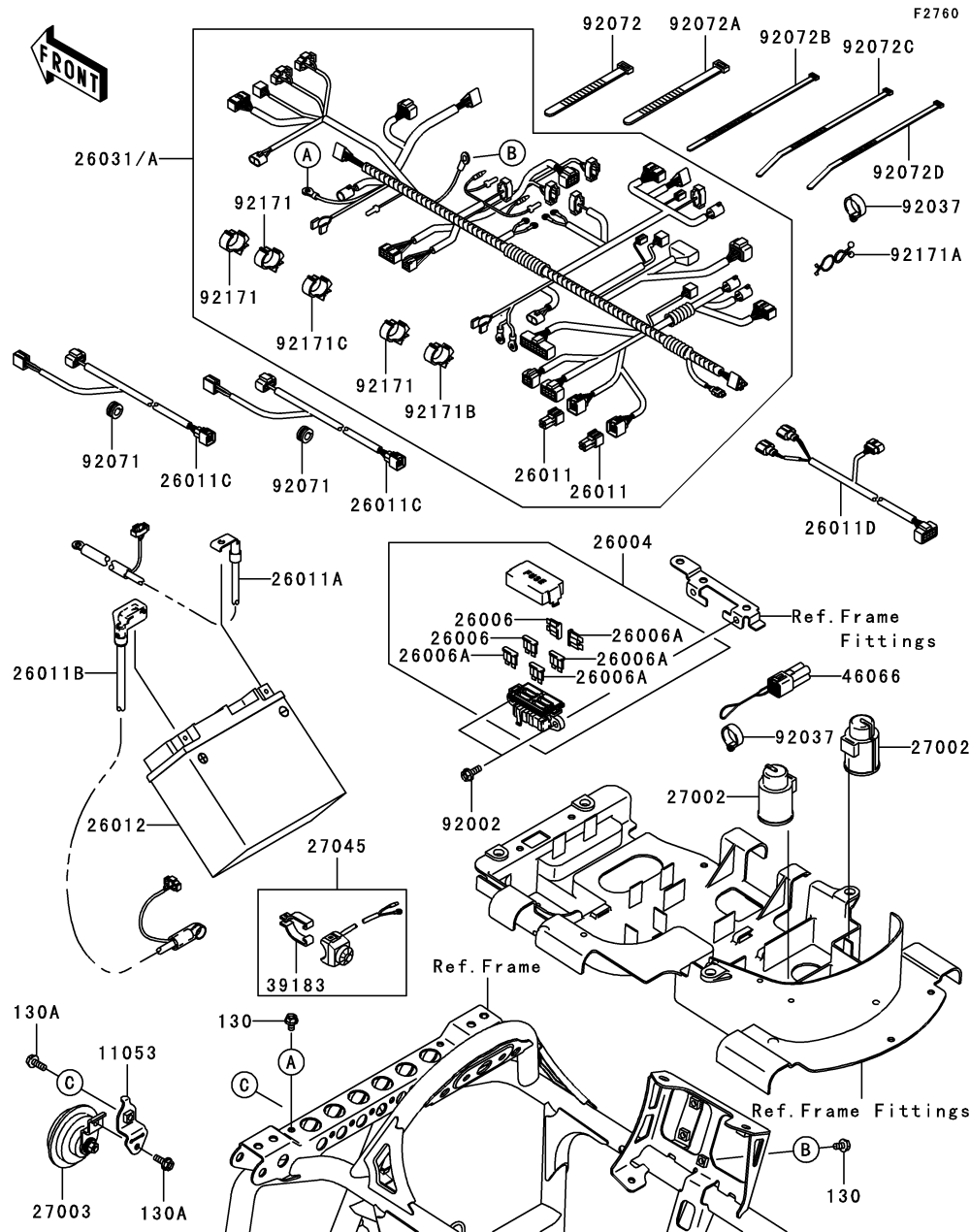

Ref. No.	Part No.	Description	Spec Code	Quantity-KVF750	
				'08	'09
				D8F	D9F
11053	11053-0912	BRACKET,HORN	1	1	
26004	26004-0016	FUSE-ASSY	1	1	
26006	26006-0004	FUSE,30A	2	2	
26006A	26006-0005	FUSE,10A	4	4	
26011	26011-0037	WIRE-LEAD	2	2	
26011A	26011-0137	WIRE-LEAD,BATTERY(-)	1	1	
26011B	26011-0138	WIRE-LEAD,BATTERY(+)	1	1	
26011C	26011-0141	WIRE-LEAD,HEAD LAMP	2	2	
26011D	26011-0150	WIRE-LEAD,HARNESS INJECTOR	1	1	
26012	26012-1414	BATTERY,MF,KMX14-BS,12V 12AH	1	1	
26031	26031-0629	HARNESS,MAIN	1		
26031A	26031-0654	HARNESS,MAIN		1	
27002	27002-1062	RELAY-ASSY	2	2	
27003	27003-1276	HORN	1	1	
27045	27045-0003	SWITCH-ASSY,HORN	1	1	
39183	39183-0002	BAND-ASSY,ENGINE STOP SWITCH	1	1	
46066	46066-0001	CONNECTOR-ASSY,RESET	1	1	
92002	92002-1571	BOLT,6X16	2	2	
92037	92037-1827	CLAMP,HOSE	10	10	
92071	92071-1128	GROMMET	2	2	
92072	92072-030	BAND,L=123	4	4	
92072A	92072-031	BAND,L=149	1	1	
92072B	92072-056	BAND,L=186	1	1	
92072C	92072-1239	BAND,L=188	4	4	
92072D	92072-3509	BAND,L=292.1	1	1	
92171	92171-0081	CLAMP,DIA=20	3	3	
92171A	92171-0476	CLAMP	1	1	
92171B	92171-1423	CLAMP,DIA=10	1	1	
92171C	92171-1424	CLAMP,DIA=15	1	1	
130	130BB0610	BOLT-FLANGED,6X10	2	2	
130A	130BB0616	BOLT-FLANGED,6X16	2	2	

This catalog covers:

'08~'09 KVF750 D8F/D9F Chassis

GRID NO.

G-10

This grid covers:

Ignition Switch

F2770

Ref. No.	Part No.	Description	Spec Code	Quantity-KVF750			
				'08	'09		
				D8F	D9F		
13151	13151-0003	SWITCH-COMP,D.C.TERMINAL	1	1			
14024	14024-1551	COVER,KEY	4	4			
	(OPTION)						
27005	27005-0019	SWITCH-ASSY-IGNITION	1	1			
27008	27008-1041	KEY-LOCK,BLANK	1	1			
	(OPTION)						
27008A	27008-1042	KEY-LOCK,BLANK	1	1			
	(OPTION)						
27008B	27008-1043	KEY-LOCK,BLANK	1	1			
	(OPTION)						
27008C	27008-1044	KEY-LOCK,BLANK	1	1			
	(OPTION)						
27008D	27008-1132	KEY-LOCK,BLANK,W/COVER	1	1			
	(OPTION)						
27008E	27008-1133	KEY-LOCK,BLANK,W/COVER	1	1			
	(OPTION)						
27008F	27008-1134	KEY-LOCK,BLANK,W/COVER	1	1			
	(OPTION)						
27008G	27008-1135	KEY-LOCK,BLANK,W/COVER	1	1			
	(OPTION)						
92210	92210-1109	NUT,IGNITION SWITCH	1	1			

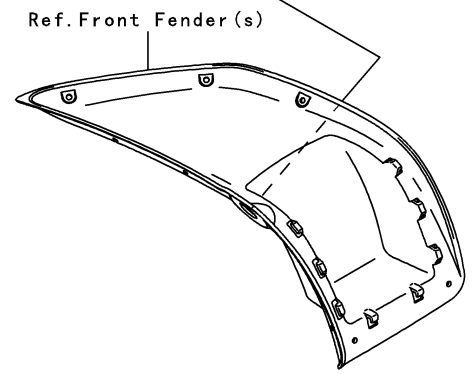
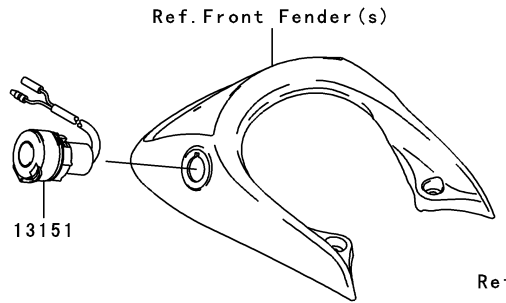
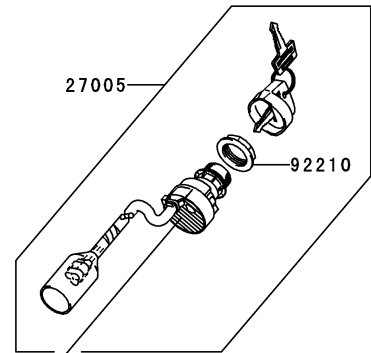
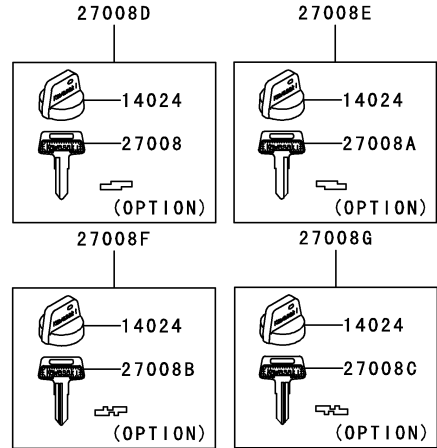

This catalog covers:

'08~'09 KVF750 D8F/D9F Chassis

GRID NO.

G-11

This grid covers:

Reflectors



F2790

Ref. No.	Part No.	Description	Spec Code	Quantity-KVF750			
				'08	'09		
28012	28012-1087	REFLECTOR-REFLEX,RR					
		L-----	EU,UK	1	1		

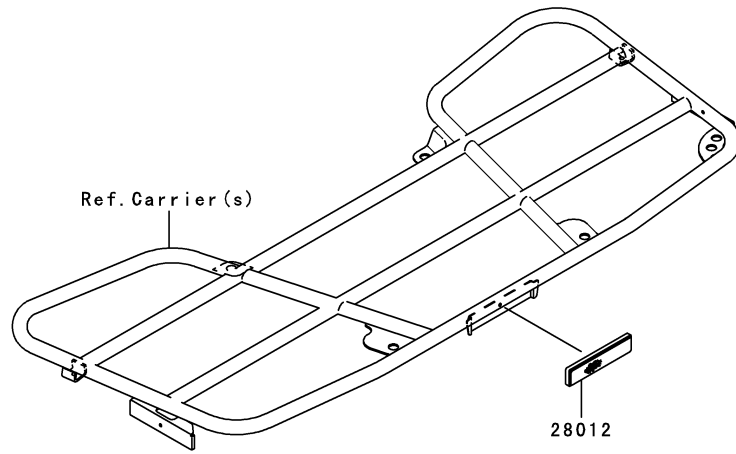

This catalog covers:

'08~'09 KVF750 D8F/D9F Chassis

GRID NO.

G-12

This grid covers:

Owner's Tools

F2810

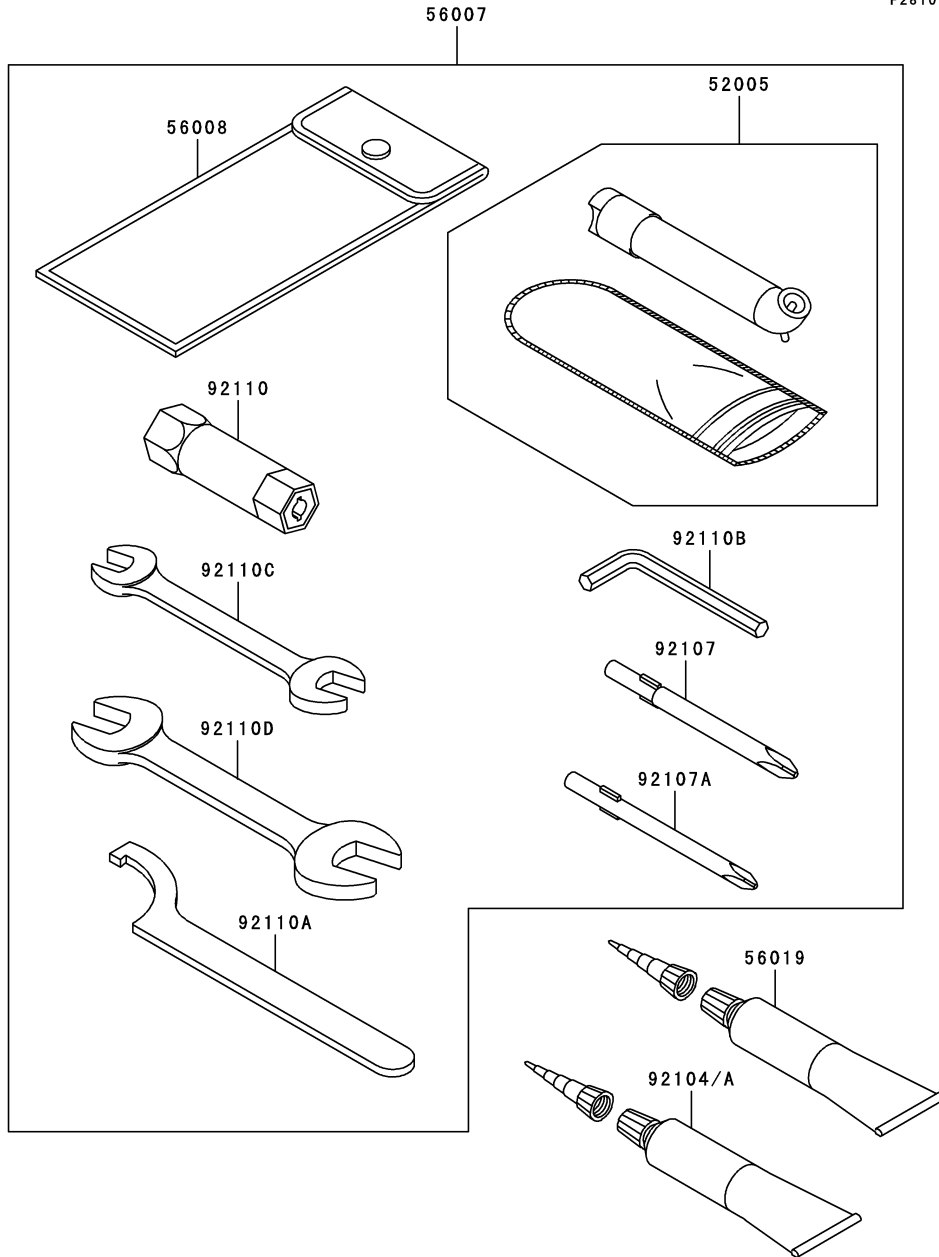

Ref. No.	Part No.	Description	Spec Code	Quantity-KVF750			
				'08	'09		
				D8F	D9F		
52005	52005-1082	GAUGE,AIR	1	1			
56007	56007-0014	TOOL-KIT	1	1			
56008	56008-1007	BAG,TOOL	1	1			
56019	56019-120	GASKET-LIQUID,TB1211,WHITE	1	1			
92104	92104-0004	GASKET-LIQUID,TB1211F,CLEAR	1	1			
92104A	92104-1063	GASKET-LIQUID,TB1216,GRAY	1	1			
92107	92107-005	TOOL-DRIVER,#3PHILLIPS	1	1			
92107A	92107-1053	TOOL-DRIVER,#2PHILLIPS	1	1			
92110	92110-1116	TOOL-WRENCH,BOX,16MM	1	1			
92110A	92110-1129	TOOL-WRENCH,HOOK	1	1			
92110B	92110-1140	TOOL-WRENCH,ALLEN,3MM	1	1			
92110C	92110-1152	TOOL-WRENCH,OPEN END,10X12	1	1			
92110D	92110-1153	TOOL-WRENCH,OPEN END,14X17	1	1			

This catalog covers:

'08~'09 KVF750 D8F/D9F Chassis

GRID NO.

G-13

This grid covers:

Labels

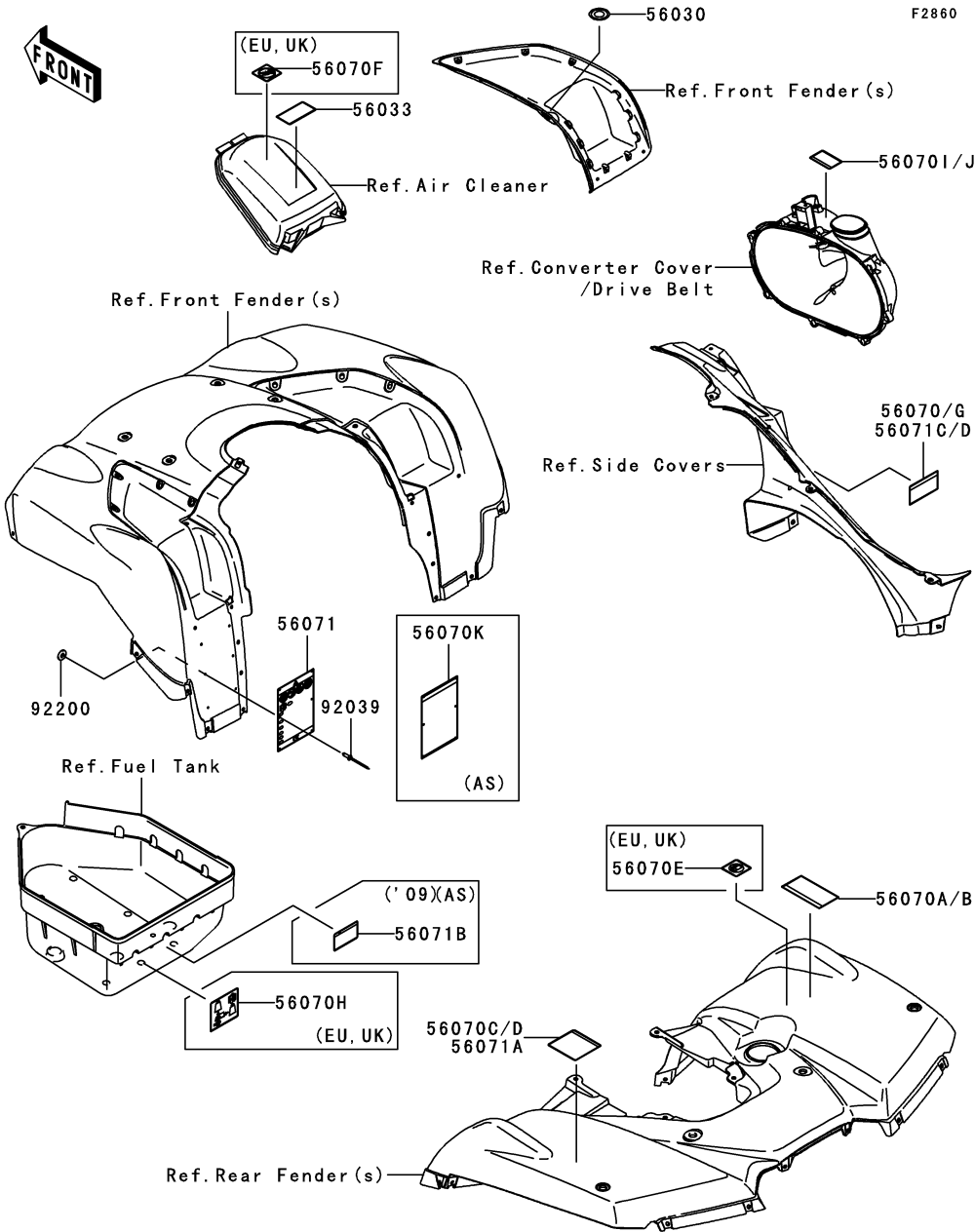

F2860

Ref. No.	Part No.	Description	Spec Code	Quantity-KVF750			
				'08	'09		
				D8F	D9F		
56030	56030-0018	LABEL,IGNITION SWITCH	1	1			
56033	56033-0064	LABEL-MANUAL,AIR CLEANER	1	1			
56070	56070-0037	LABEL-WARNING,SHIFT LEVER(FRENCH)					
	L-----	EU	1				
56070A	56070-0038	LABEL-WARNING,DRIVE BELT	1	1			
56070B	56070-0039	LABEL-WARNING,DRIVE BELT(FRENCH)					
	L-----	EU	1	1			
56070C	56070-0045	LABEL-WARNING,TIRE&MAX LOAD					
	L-----	AS	1				
56070D	56070-0046	LABEL-WARNING,TIRE INFO					
	L-----	EU,UK	1	1			
56070E	56070-1108	LABEL-WARNING,FUEL UNLEADED					
	L-----	EU,UK	1	1			
56070F	56070-1110	LABEL-WARNING,AGE RECOMMEND					
	L-----	EU,UK	1	1			
56070G	56070-1170	LABEL-WARNING,SHIFT LEVER	1				
56070H	56070-1266	LABEL-WARNING,TOWING					
	L-----	EU,UK	1	1			
56070I	56070-1269	LABEL-WARNING,CVT COVER	1	1			
56070J	56070-1271	LABEL-WARNING,CVT COVER(FRENCH)					
	L-----	EU	1	1			
56070K	56070-1286	LABEL-WARNING,GENERAL					
	L-----	AS	1	1			
56071	56071-0036	LABEL-WARNING,GENERAL					
	L-----	EU,UK	1	1			
56071A	56071-0073	LABEL-WARNING,TIRE&MAX LOAD					
	L-----	AS	1				
56071B	56071-0079	LABEL-WARNING,TOWING					
	L-----	AS	1				
56071C	56071-0090	LABEL-WARNING,SHIFT LEVER	1				
56071D	56071-0092	LABEL-WARNING,SHIFT LEVER(FRENCH)					
	L-----	EU	1				
92039	92039-3763	RIVET,3.2X8	6	6			
92200	92200-1251	WASHER,3.5X8X1	6	6			

This catalog covers:

'08~'09 KVF750 D8F/D9F Chassis

GRID NO.

G-14

This grid covers:

Decals(Black)(D8F)(EU,UK)

F2861

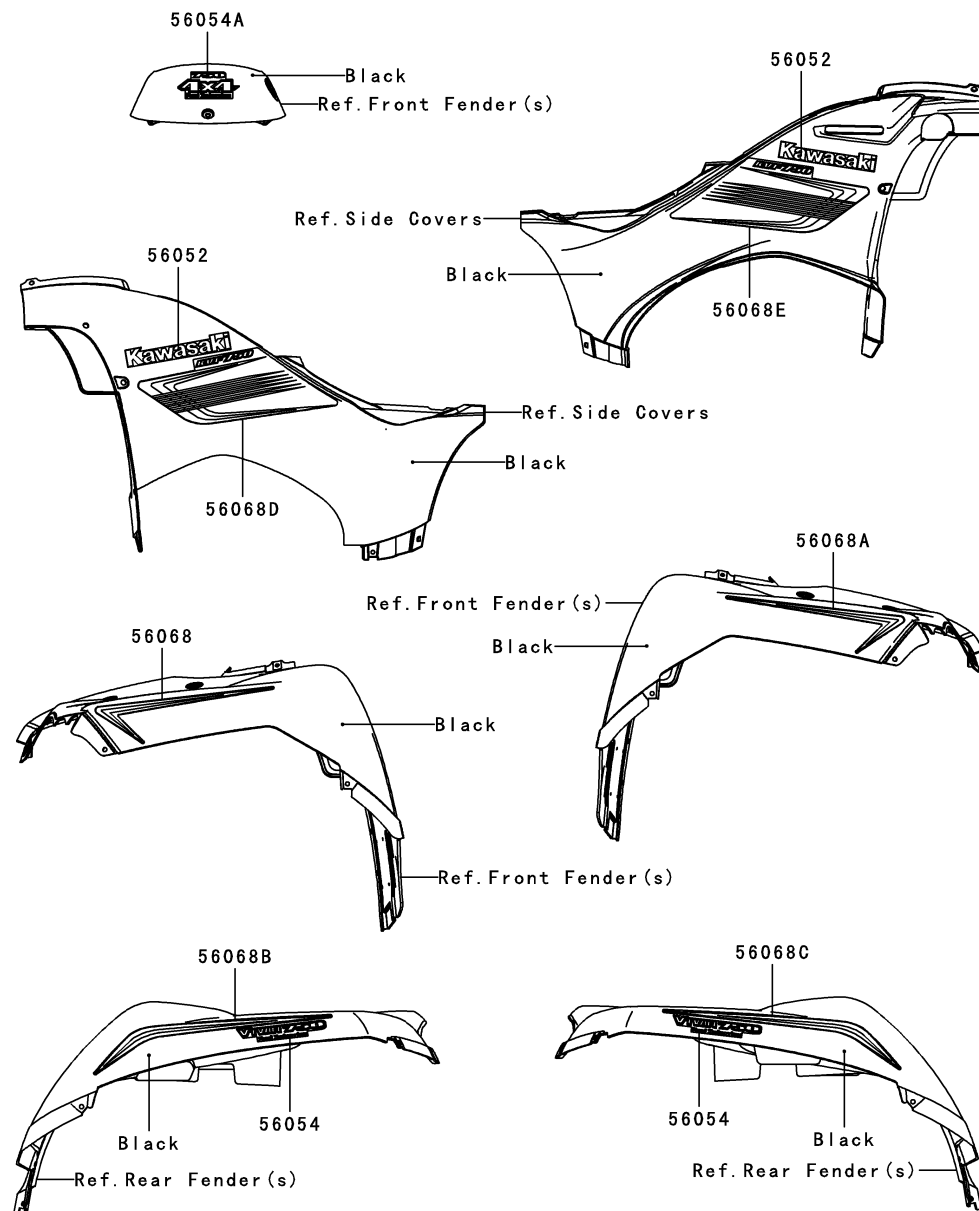

Ref. No.	Part No.	Description	Spec Code	Quantity-KVF750			
				'08	'09		
56052	56052-0947	MARK,SIDE COVER,KAWASAKI					
	L-----		EU,UK	2			
56054	56054-0095	MARK,RR FENDER,V TWIN 750					
	L-----		EU,UK	2			
56054A	56054-0096	MARK,TOP COVER,750 4X4					
	L-----		EU,UK	1			
56068	56068-0357	PATTERN,FR FENDER,LH					
	L-----		EU,UK	1			
56068A	56068-0358	PATTERN,FR FENDER,RH					
	L-----		EU,UK	1			
56068B	56068-0411	PATTERN,RR FENDER,LH					
	L-----		EU,UK	1			
56068C	56068-0412	PATTERN,RR FENDER,RH					
	L-----		EU,UK	1			
56068D	56068-0503	PATTERN,SIDE COVER,LH					
	L-----		EU,UK	1			
56068E	56068-0504	PATTERN,SIDE COVER,RH					
	L-----		EU,UK	1			

This catalog covers:

'08~'09 KVF750 D8F/D9F Chassis

GRID NO.

H-3

This grid covers:

Decals(W.Green)(D8F)(EU,UK)

F2861A

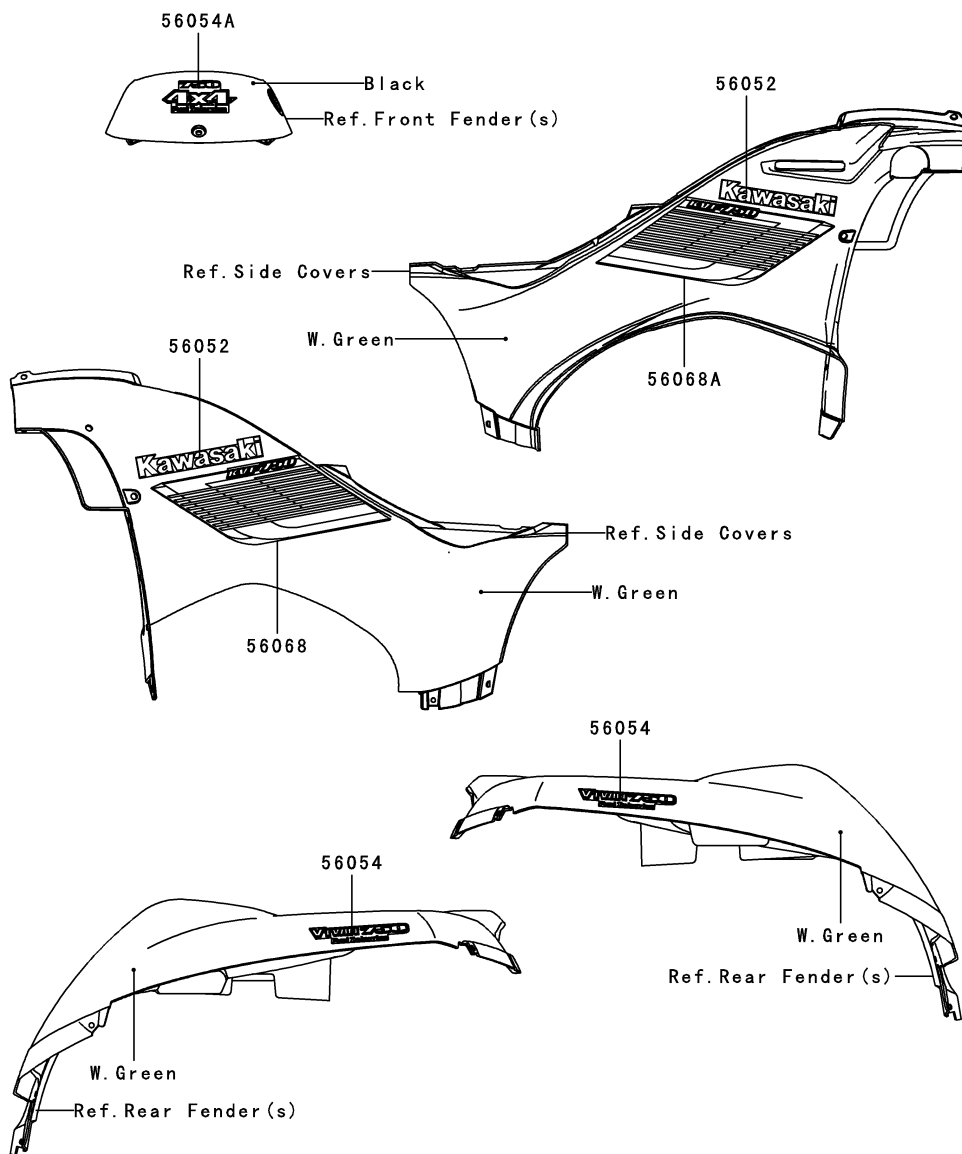

Ref. No.	Part No.	Description	Spec Code	Quantity-KVF750			
				'08	'09		
56052	56052-0947	MARK,SIDE COVER,KAWASAKI					
		L-----	EU,UK	2			
56054	56054-0093	MARK,RR FENDER,V TWIN 750					
		L-----	EU,UK	2			
56054A	56054-0096	MARK,TOP COVER,750 4X4					
		L-----	EU,UK	1			
56068	56068-0501	PATTERN,SIDE COVER,LH					
		L-----	EU,UK	1			
56068A	56068-0502	PATTERN,SIDE COVER,RH					
		L-----	EU,UK	1			

This catalog covers:

'08~'09 KVF750 D8F/D9F Chassis

GRID NO.

H-4

This grid covers:

Decals(L.Green)(D8F)(AS)

F2861B

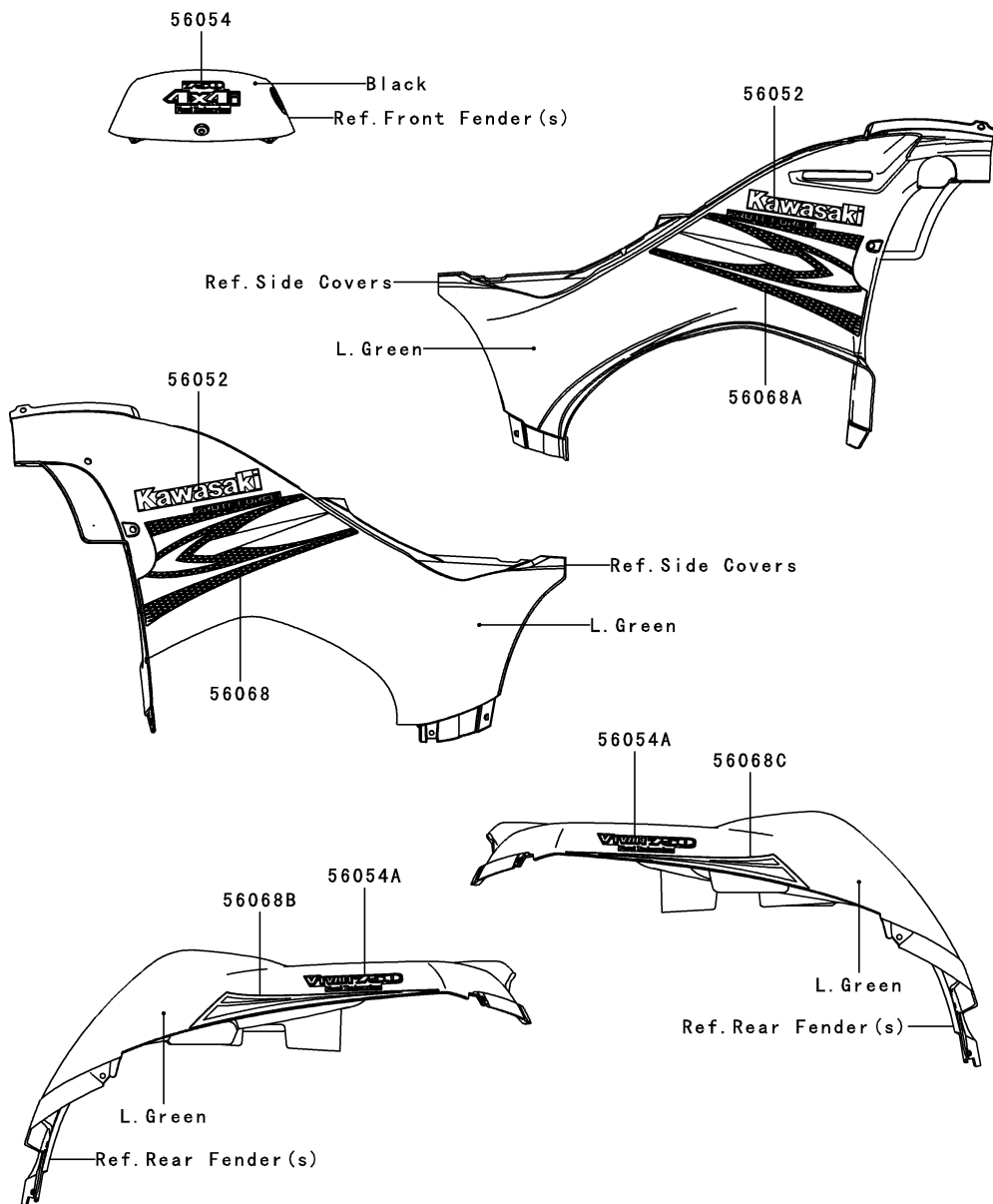

Ref. No.	Part No.	Description	Spec Code	Quantity-KVF750			
				'08	'09		
56052	56052-0455	MARK,SIDE COVER,KAWASAKI	AS	2			
56054	56054-0092	MARK, TOP COVER,750 4X4I	AS	1			
56054A	56054-0094	MARK,RR FENDER,V TWIN 750	AS	2			
56068	56068-0497	PATTERN,SIDE COVER,LH	AS	1			
56068A	56068-0498	PATTERN,SIDE COVER,RH	AS	1			
56068B	56068-0499	PATTERN,RR FENDER,LH	AS	1			
56068C	56068-0500	PATTERN,RR FENDER,RH	AS	1			

This catalog covers:

'08~'09 KVF750 D8F/D9F Chassis

GRID NO.

H-5

This grid covers:

Decals(Black)(D9F)(EU,UK)

F28610

Ref. No.	Part No.	Description	Spec Code	Quantity-KVF750			
				'08	'09		
				D8F	D9F		
56052	56052-0947	MARK,FR FENDER,KAWASAKI					
	L-----		EU,UK			2	
56054	56054-0229	MARK,FUEL INJECTED V-TWIN					
	L-----		EU,UK			1	
56068	56068-1154	PATTERN,FR FENDER,LH					
	L-----		EU,UK			1	
56068A	56068-1155	PATTERN,FR FENDER,RH					
	L-----		EU,UK			1	
56068B	56068-1156	PATTERN,RR FENDER,LH					
	L-----		EU,UK			1	
56068C	56068-1157	PATTERN,RR FENDER,RH					
	L-----		EU,UK			1	
56068D	56068-1164	PATTERN,SIDE COVER,LH					
	L-----		EU,UK			1	
56068E	56068-1165	PATTERN,SIDE COVER,RH					
	L-----		EU,UK			1	

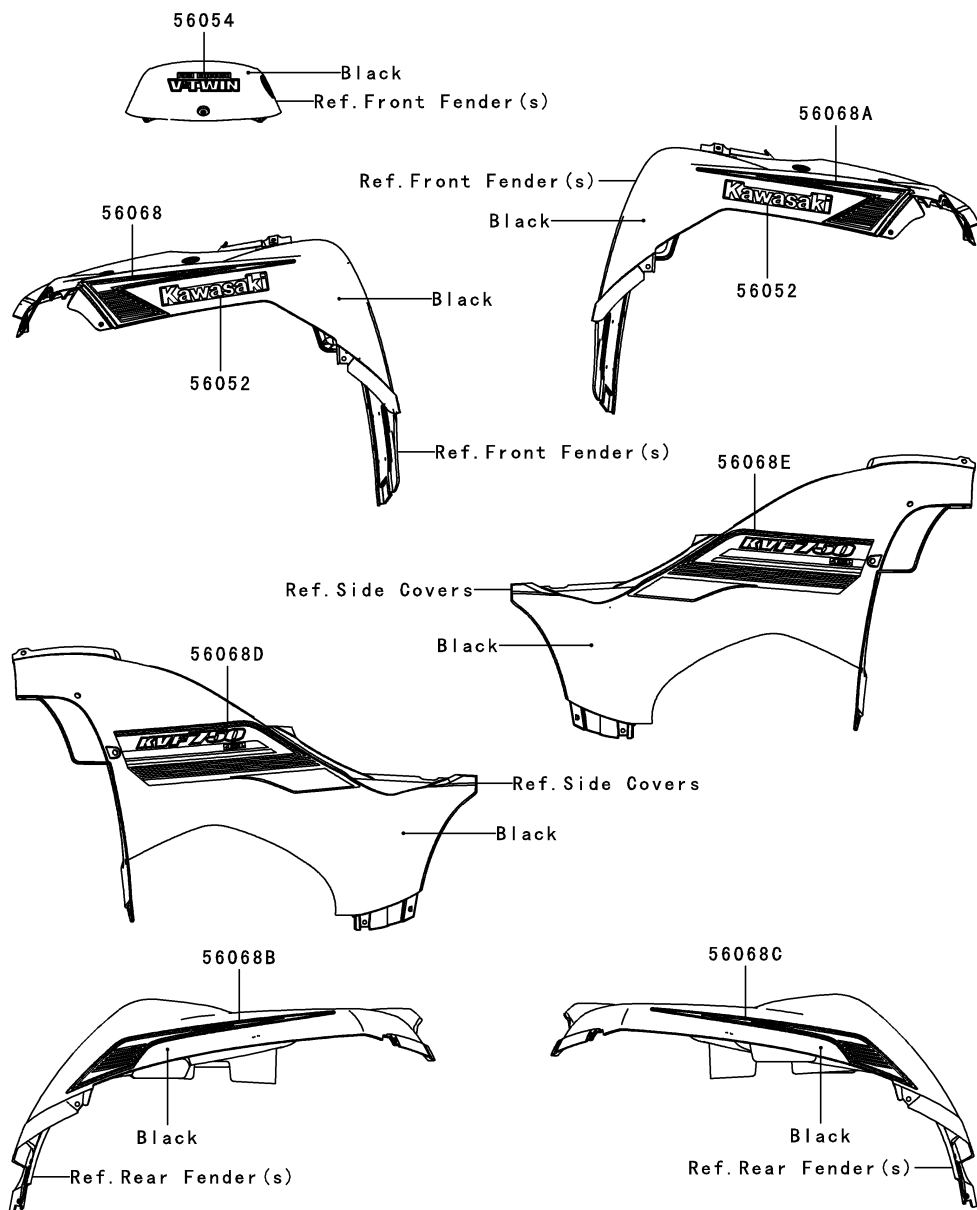

This catalog covers:

'08~'09 KVF750 D8F/D9F Chassis

GRID NO.

H-6

This grid covers:

Decals(W.Green)(D9F)(EU,UK)

F2861D

Ref. No.	Part No.	Description	Spec Code	Quantity-KVF750			
				'08	'09		
56052	56052-0947	MARK,FR FENDER,KAWASAKI					
	L-----						
56054	56054-0229	MARK,FUEL INJECTED V-TWIN					
	L-----						
56068	56068-1144	PATTERN,FR FENDER,LH					
	L-----						
56068A	56068-1145	PATTERN,FR FENDER,RH					
	L-----						
56068B	56068-1146	PATTERN,RR FENDER,LH					
	L-----						
56068C	56068-1147	PATTERN,RR FENDER,RH					
	L-----						
56068D	56068-1162	PATTERN,SIDE COVER,LH					
	L-----						
56068E	56068-1163	PATTERN,SIDE COVER,RH					
	L-----						

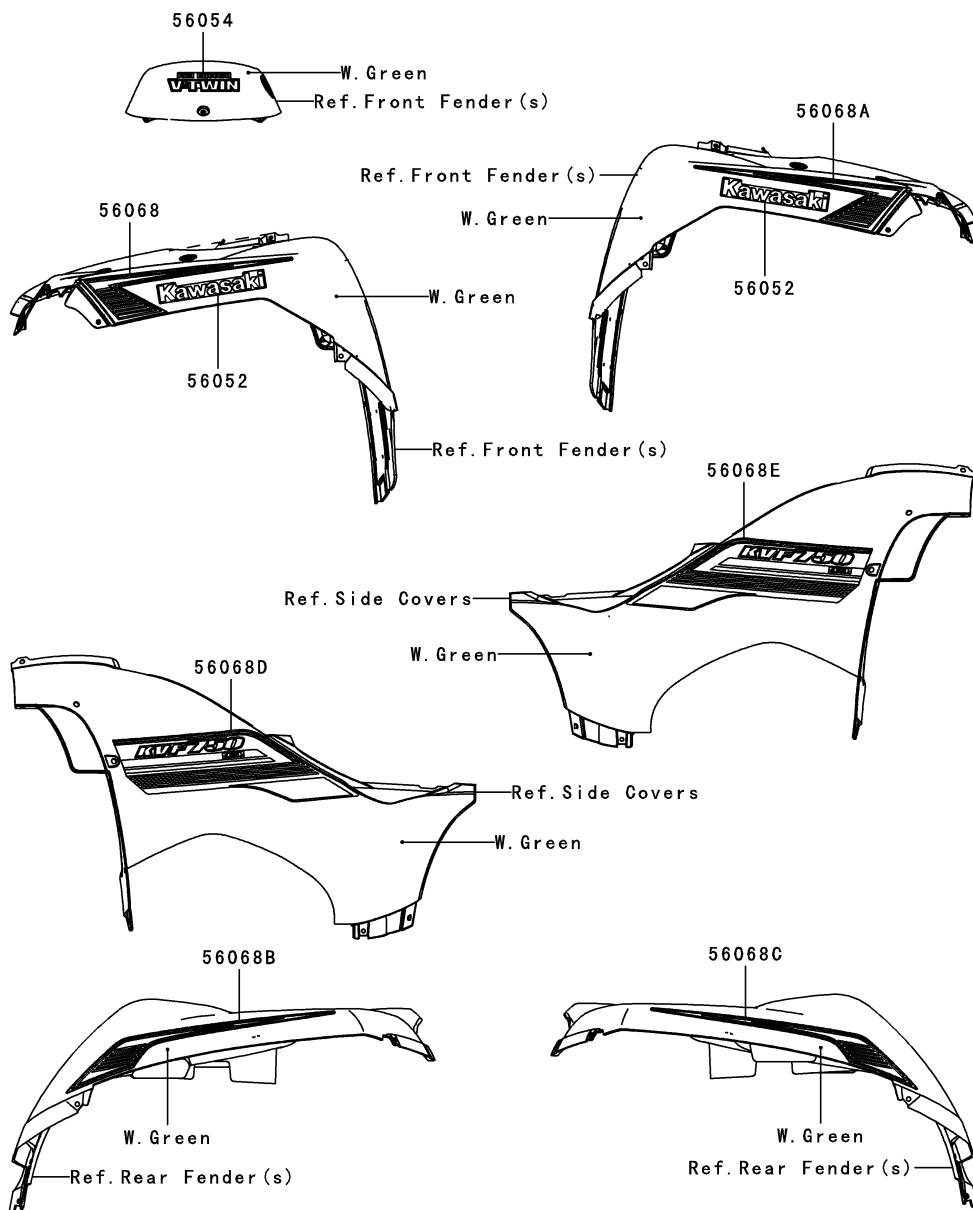

This catalog covers:

'08~'09 KVF750 D8F/D9F Chassis

GRID NO.

H-7

This grid covers:

Decals(L.Green)(D9F)(AS)

F2861E

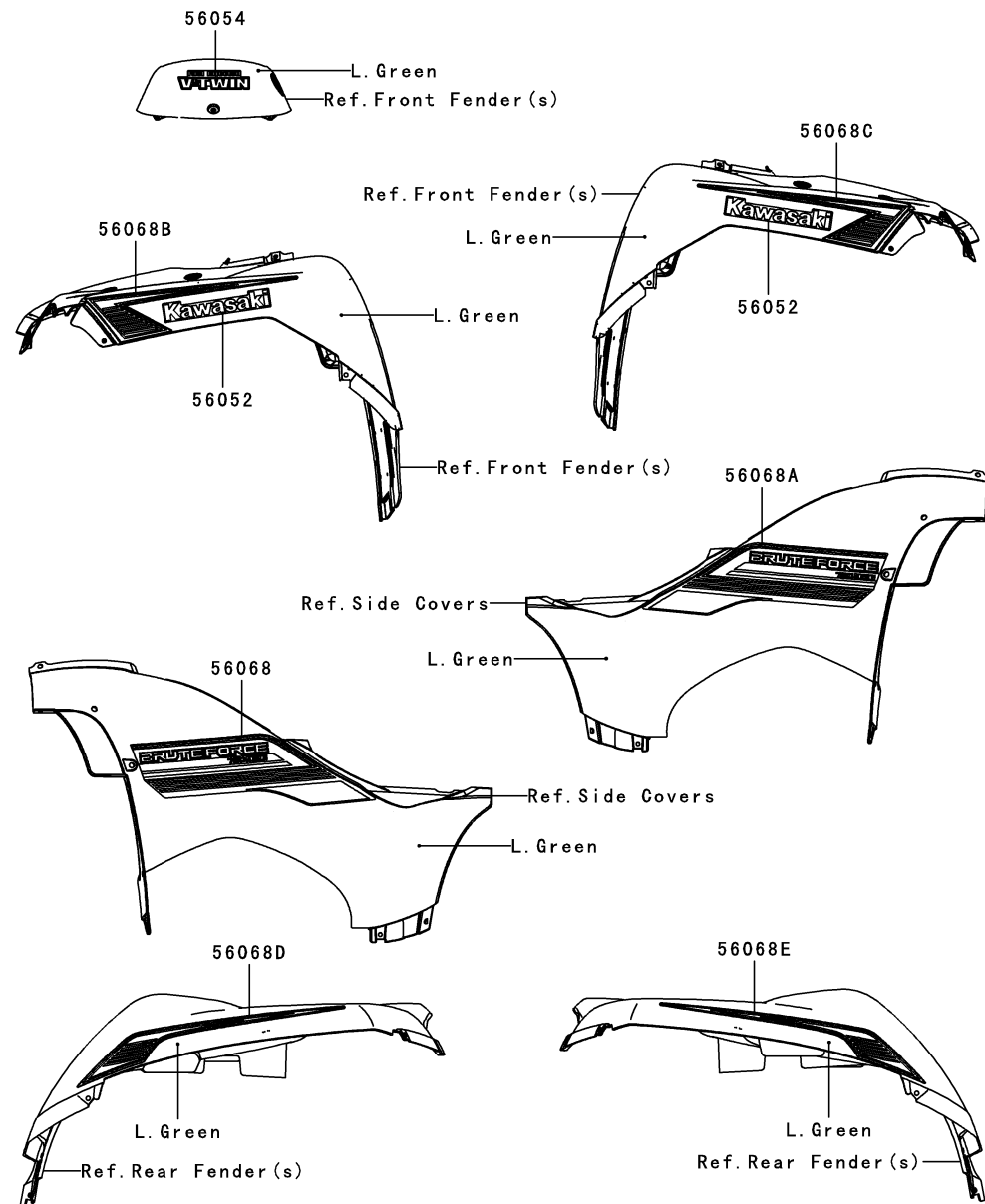

Ref. No.	Part No.	Description	Spec Code	Quantity-KVF750			
				'08	'09		
56052	56052-0455	MARK,FR FENDER,KAWASAKI					
	L-----		AS				2
56054	56054-0229	MARK,FUEL INJECTED V-TWIN					
	L-----		AS				1
56068	56068-1138	PATTERN,SIDE COVER,LH					
	L-----		AS				1
56068A	56068-1139	PATTERN,SIDE COVER,RH					
	L-----		AS				1
56068B	56068-1148	PATTERN,FR FENDER,LH					
	L-----		AS				1
56068C	56068-1149	PATTERN,FR FENDER,RH					
	L-----		AS				1
56068D	56068-1150	PATTERN,RR FENDER,LH					
	L-----		AS				1
56068E	56068-1151	PATTERN,RR FENDER,RH					
	L-----		AS				1

This catalog covers:

'08~'09 KVF750 D8F/D9F Chassis

GRID NO.

H-8

This grid covers:

Optional Parts

F2890

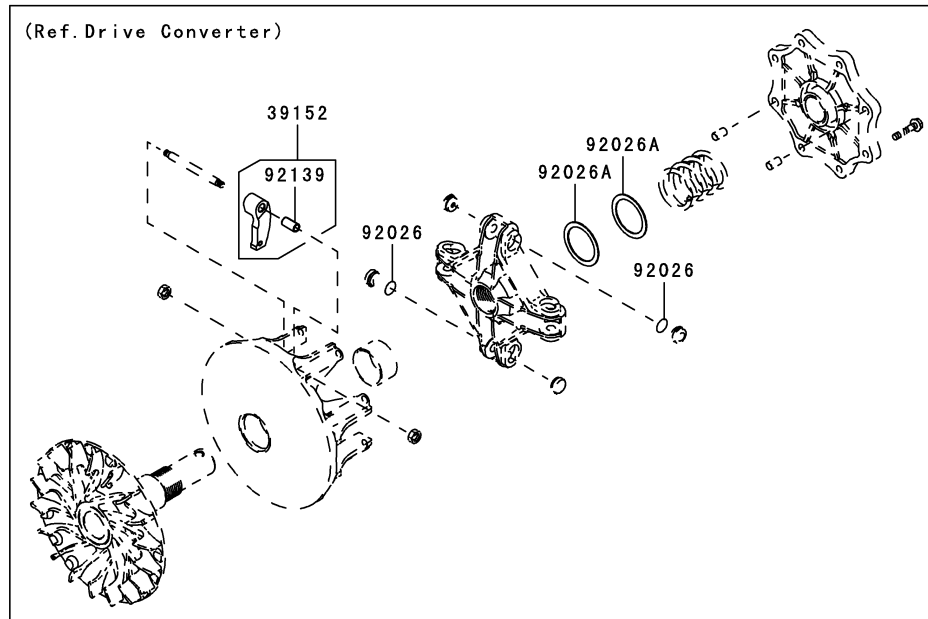
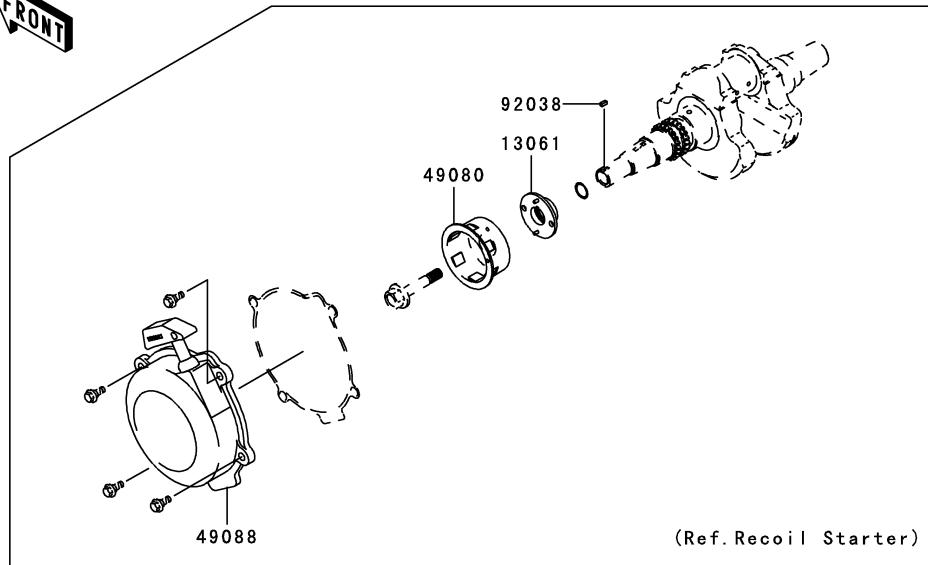

Ref. No.	Part No.	Description	Quantity-KVF750			
			'08	'09		
			D8F	D9F		
13061	13061-1873	BOSS	1	1		
39152	39152-0028	WEIGHT-RAMP	4	4		
	(OPTION)					
49080	49080-1061	PULLEY-STARTING	1	1		
49088	49088-1058	STARTER-RECOIL	1	1		
92026	92026-0038	SPACER,T=0.1	2	2		
92026A	92026-1603	SPACER,39X49.5X1.0	2	2		
	(OPTION)					
92038	92038-1051	KEY,SUNK	1	1		
92139	92139-0215	BUSHING	4	4		

This catalog covers:

'08~'09 KVF750 D8F/D9F Chassis

GRID NO.

H-9

This grid covers:

Manual(EU,UK)

F2920

Owner's Manual
(Local Procurement)

99923/A
99947/A
99972/A
99977/A
99984/A
99992/A

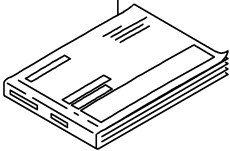

Ref. No.	Language
(99923/A)	German
(99947/A)	French
(99972/A)	Spanish
(99977/A)	English
(99984/A)	Dutch
(99992/A)	Italian

Ref. No.	Part No.	Description	Spec Code	Quantity-KVF750			
				'08	'09		
				D8F	D9F		
99923	99923-1619	OWNER'S MANUAL,GERMAN					
	L-----		EU,UK	1			
99923A	99923-1625	OWNER'S MANUAL,GERMAN					
	L-----		EU,UK		1		
99947	99947-1380	OWNER'S MANUAL,FRENCH					
	L-----		EU,UK		1		
99947A	99947-1386	OWNER'S MANUAL,FRENCH					
	L-----		EU,UK		1		
99972	99972-1109	OWNER'S MANUAL,SPANISH					
	L-----		EU,UK		1		
99972A	99972-1129	OWNER'S MANUAL,SPANISH					
	L-----		EU,UK		1		
99977	99977-1280	OWNER'S MANUAL,ENGLISH					
	L-----		EU,UK		1		
99977A	99977-1332	OWNER'S MANUAL,ENGLISH					
	L-----		EU,UK		1		
99984	99984-1084	OWNER'S MANUAL,DUTCH					
	L-----		EU,UK		1		
99984A	99984-1094	OWNER'S MANUAL,DUTCH					
	L-----		EU,UK		1		
99992	99992-1048	OWNER'S MANUAL,ITALIAN					
	L-----		EU,UK		1		
99992A	99992-1057	OWNER'S MANUAL,ITALIAN					
	L-----		EU,UK		1		

This catalog covers:

'08~'09 KVF750 D8F/D9F

GRID NO.

L-12

This grid covers:

Numerical Parts Index

Part No.	Grid No.	Part No.	Grid No.	Part No.	Grid No.	Part No.	Grid No.	Part No.	Grid No.	Part No.	Grid No.
11004-0011	B-3	11065-0194-6Z	E-10	130BB0812	E-6	13262-0434	B-10	132BD0630	C-13	14091-0179	E-10
11005-0022	B-4	11065-1151	C-4	130BB0812	E-8	13262-0491	B-10	132BD0630	C-4	14091-0252-6Z	E-12
11005-0023	B-4	11065-1152	B-3	130BB0814	G-6	13262-0494	D-3	132BD0630	C-8	14091-0270-286	E-10
11008-0087	B-3	11065-1153	F-4	130BB0820	F-6	13271-0539	D-8	132BD0630	D-7	14091-0270-6Z	E-10
11008-0088	B-3	11065-1153	F-5	130BB0825	E-6	13271-0976	E-14	132BD0640	B-4	14091-0309	C-4
11009-1145	C-12	112AA0622	F-6	130BB1016	G-6	13271-0980	C-6	132BD0640	C-3	14091-0337	E-10
11009-1373	E-5	115CB0855	E-3	130BD0616	B-6	13271-1259	F-10	132BD0655	C-4	14091-0338	E-5
11009-1430	B-7	12004-0007	B-7	130CA0630	B-12	13271-1369	C-9	132BD0665	C-3	14091-0491	E-13
11009-1865	B-6	12005-0047	B-7	130CA0860	F-11	13271-1497	D-5	132BD0665	C-4	14091-0492	E-13
11009-1894	B-6	12009-1056	B-7	130CB1016	E-9	13271-1503	D-5	132BD0695	B-3	14091-0540	E-5
11010-0152-6Z	B-5	12011-1051	B-7	130CB1016	F-14	13271-1635	F-10	132BD08110	C-3	14091-0608	F-12
11011-0017-6Z	B-5	12016-1128	B-7	130CD0620	B-11	13271-1636	F-10	132BD0875	C-3	14091-0736-6Z	G-7
11012-1084	C-12	12016-1129	B-7	130CD0620	B-14	13271-7506	E-3	132E0620	C-13	14091-0737	C-5
11012-1354	C-11	12020-0004	B-7	130CD0825	B-6	13280-0082	C-12	13310-0013	D-8	14091-0738	C-14
11012-1367	E-5	12046-0021	B-8	130CD0825	D-10	13280-0232	B-5	13310-0014	D-8	14091-0961-286	G-6
11013-0021	B-5	12046-1203	B-8	130CD0860	D-9	13280-0233	B-5	13320-1018	F-10	14091-0961-290	G-6
11050-1932	G-3	12048-1176	B-8	13107-0029	B-8	13280-1226	F-10	14001-0015	C-3	14091-0961-6Z	G-6
11051-1929	E-4	12048-1177	B-8	13107-0114	D-3	13280-1227	F-10	14001-0109	C-3	14091-1197	D-5
11052-1476	D-10	12053-1440	C-8	13107-0123	D-5	132BA0625	B-3	14014-0006	C-3	14091-1365	C-4
11053-0642	F-6	12053-1441	B-8	13107-0158	B-10	132BA0625	C-12	14014-1148	B-8	14091-1403	F-10
11053-0912	G-9	12053-1442	B-8	13107-0177	B-10	132BA0625	G-7	14024-1551	G-10	14091-1421	B-14
11053-0936	F-12	12053-1443	B-8	13107-1443	B-8	132BA0640	F-6	14031-0030	C-4	16007-1178	B-7
11053-0937	E-5	12053-1444	B-8	13107-1444	B-8	132BA0822	C-10	14037-0045	C-12	16007-1203	B-13
11053-0958	E-5	120CA0610	B-8	13107-1505	D-4	132BB0512	F-8	14041-0004	B-14	16007-1205	D-4
11053-0969	E-5	120CA0612	D-3	13127-0053	B-10	132BB0612	E-7	14041-1136	B-11	16007-1221	B-13
11053-1592	E-4	120CA0816	C-11	13139-0003	B-10	132BB0612	E-8	14041-1159	B-12	16065-0046	B-3
11053-1638	E-5	120CB0614	B-8	13139-1097	D-5	132BB0612	E-9	14041-1160	B-12	16073-0030	G-5
11053-1833	E-8	120CB0630	C-9	13151-0003	G-10	132BB0630	F-8	14041-1161	B-12	16073-0031	E-12
11053-1979	E-13	13001-0021	B-4	13151-1080	B-11	132BB0635	E-6	14055-0014	D-5	16073-0032	E-12
11053-1980	E-13	13002-1060	B-4	13168-0042	D-8	132BB0650	C-8	14055-1155	D-5	16073-0033	F-12
11054-1229	E-9	13008-0008	B-4	13168-1715	F-10	132BB0650	D-10	14055-1156	D-5	16073-0034	F-12
11054-1232	E-9	13031-0079	B-9	13168-1724	D-5	132BB0690	C-12	14057-0002	D-8	16073-0035	E-5
11054-1236	E-5	13042-1141	B-8	13168-1725	D-5	132BB0814	E-4	14057-1004	D-5	16073-0036	E-5
11054-1318	E-5	13061-1873	H-8	13168-1736	F-10	132BD0610	C-10	14067-006	C-3	16073-0037	E-13
11054-1328	C-10	13070-1352	B-11	13194-1094	C-11	132BD0612	B-3	14069-1051	C-4	16073-0038	E-13
11054-1468	B-3	13070-1396	D-10	13216-0017	D-8	132BD0612	B-4	14073-0025	B-14	16085-1238	C-11
11060-1174	G-8	13096-1163	D-5	13234-1112	C-8	132BD0612	C-13	14073-0026	B-14	16087-0002	F-12
11060-1287	B-11	130BA0516	C-9	13236-0034	D-10	132BD0612	C-4	14073-0027	B-14	16097-0003	C-8
11060-1956	B-11	130BA0616	F-12	13236-0046	B-14	132BD0612	C-8	14073-0028	B-14	16115-1072	C-4
11060-1964	C-12	130BA0630	F-12	13236-0047	B-14	132BD0612	C-9	14073-0160	B-5	16126-4001	E-14
11060-1966	B-8	130BA0635	D-7	13236-0048	B-14	132BD06130	B-3	14091-0136-6Z	E-10	16126-4001	F-3
11060-1982	D-5	130BB0518	C-10	13236-0051	B-11	132BD0618	C-5	14091-0137-286	G-5	16130-1058	C-8
11060-1994	B-3	130BB0610	G-9	13236-1343	B-11	132BD0620	B-3	14091-0137-290	G-5	16142-0002	C-12
11061-0059	D-8	130BB0614	G-6	13251-1143	B-9	132BD0620	C-10	14091-0137-839	G-5	16142-1162	C-8
11061-0063	B-4	130BB0616	E-12	13260-1867	B-10	132BD0620	C-4	14091-0138-286	G-5	16146-0011	G-3
11061-0072	E-5	130BB0616	E-6	13262-0234	B-10	132BD0630	B-11	14091-0138-290	G-5	16154-2059	C-8
11061-1119	C-4	130BB0616	E-9	13262-0235	B-10	132BD0630	B-3	14091-0138-839	G-5	16154-2060	C-8
11061-1153	C-14	130BB0616	G-9	13262-0313	B-10	132BD0630	B-4	14091-0142	D-8	16160-0046	C-12
11065-0086	E-8	130BB0620	C-9	13262-0314	B-10	132BD0630	B-8	14091-0143	D-8	16160-0127	C-12
11065-0088	E-5	130BB0625	E-12	13262-0433	B-10	132BD0630	C-11	14091-0164	B-5	16163-0125	C-5

This catalog covers:

'08~'09 KVF750 D8F/D9F

GRID NO.

L-13

This grid covers:

Numerical Parts Index

Part No.	Grid No.	Part No.	Grid No.	Part No.	Grid No.	Part No.	Grid No.	Part No.	Grid No.	Part No.	Grid No.
16172-0006	B-14	25008-0003	G-3	34028-0055-6Z	E-9	39183-1065	E-5	43049-1088	F-10	49006-1242	F-9
16172-0007	D-5	25009-004	G-3	34028-0087-21	E-9	39186-0030	E-8	43056-1055	F-9	49006-1292	B-5
18018-0009	E-5	25031-0163	G-3	35004-0047-286	E-10	39186-0033	E-7	43057-1001	F-9	49006-1338	F-8
18018-0010	C-5	25031-0164	G-3	35004-0047-290	E-10	39186-0034	E-7	43078-0024	C-12	49006-1362	D-4
18020-0008	F-12	25031-0226	G-3	35004-0047-839	E-10	39192-0033	B-3	43080-0019-DJ	F-9	49016-1044	F-8
18087-0167	B-6	25031-0227	G-3	35004-0106-286	E-10	39192-0034	B-3	43080-0020-DJ	F-9	49022-0009	D-8
18088-0379	B-6	26004-0016	G-9	35004-0106-290	E-10	39193-0015	C-8	43082-0022	F-9	49022-0010	D-3
180BD0612	B-6	26006-0004	G-9	35004-0106-839	E-10	39193-1052	C-8	43082-0023	F-9	49022-0011	D-3
21003-0071	C-9	26006-0005	G-9	35023-0050-286	E-12	39193-1053	C-8	43095-0078	F-8	49022-1177	D-5
21007-0111	C-9	26011-0037	G-9	35023-0050-290	E-12	39193-1054	C-8	45014-0203-17D	F-7	49022-1178	D-5
21007-1416	D-3	26011-0111	C-11	35023-0050-839	E-12	41009-0039	E-14	45014-0203-CD	F-7	49022-1190	D-5
21008-0001	C-12	26011-0137	G-9	35063-0164	F-14	41009-0039	F-3	45014-0203-EH	F-7	49022-1201	D-5
21017-017	C-11	26011-0138	G-9	35063-0394	E-9	41009-0112	E-14	45014-0203-VM	F-7	49030-0032	F-4
21039-0004	C-11	26011-0141	G-9	35063-0395	E-9	41009-0112	F-3	45014-0204-17D	F-7	49030-0034	F-5
21040-0003	C-11	26011-0150	G-9	35063-0501-388	F-14	41025-0087	E-14	45014-0204-CD	F-7	49033-1060	C-5
21064-002	C-11	26011-1755	C-8	39007-0021	E-8	41025-0087	F-3	45014-0204-EH	F-7	49040-0033	C-6
21066-0030	C-9	26012-1414	G-9	39007-0022	E-8	41025-0088	E-14	45014-0204-VM	F-7	49047-1104	B-11
21121-0039	C-10	26031-0629	G-9	39007-0038	E-8	41025-0116	F-3	46003-1580	F-10	49048-1087	B-12
21130-1071	C-10	26031-0654	G-9	39007-0039	E-8	41046-1101	D-3	46012-1168	F-10	49048-1088	B-12
21163-0037	C-11	27002-1062	C-7	39007-0064	E-7	41046-1102	D-3	46066-0001	G-9	49048-1089	B-12
21175-0086	C-10	27002-1062	G-9	39007-0065	E-7	41053-0006	F-6	46075-0046	D-10	49048-1090	B-12
21175-0137	C-7	27003-1276	G-9	39007-0066	E-7	41072-007	F-6	46075-7501	F-10	49048-1091	B-12
21175-0216	C-10	27005-0019	G-10	39007-0067	E-7	41080-1482	D-8	46076-1238	F-10	49048-1092	B-12
21176-0009	C-7	27008-1041	G-10	39012-0005	E-5	41080-1483	D-8	46091-0111	F-10	49048-1093	B-12
21176-0048	C-7	27008-1042	G-10	39012-0015-6Z	E-11	41080-1484	D-8	46092-1208	F-8	49048-1094	B-12
21176-0058	C-5	27008-1043	G-10	39012-5013	E-5	41080-1499	D-5	46102-0055	E-8	49048-1095	B-12
21176-0066	C-7	27008-1044	G-10	39031-0011	G-6	41080-1500	D-5	46102-0056	E-8	49050-0010	B-12
21176-1104	C-10	27008-1132	G-10	39060-0040	C-12	41080-1501	D-5	480J1000	B-14	49054-1055	C-12
21176-1109	C-10	27008-1133	G-10	39062-0178	C-12	41080-1512	D-5	480J1400	B-8	49056-0021	C-5
220AA0308	F-11	27008-1134	G-10	39062-0180	C-12	41080-1513	F-9	480J2800	D-3	49063-1055	C-12
220AA0408	C-5	27008-1135	G-10	39062-0226	C-12	410AA0800	B-8	481J2400	E-7	49065-1086	C-8
220AA0408	D-9	27010-0025	F-8	39062-0227	C-12	42034-0006	D-8	481J2400	E-8	49074-1055	B-13
220AA0612	C-5	27010-1098	C-11	39062-0241	C-12	42034-1192	D-5	481J2500	D-4	49078-0014	B-7
220AB0525	F-11	27010-1294	F-10	39074-0002	F-10	42034-1193	D-4	481J2500	D-7	49080-1061	H-8
220AB0535	F-11	27010-1313	C-8	39075-1062	F-10	42036-0016	E-7	481J3700	C-3	49085-1066	C-12
220AB0625	F-11	27010-1494	F-6	39076-0005	C-11	42036-0018	F-7	481J5200	E-8	49088-1058	H-8
221AA0616	C-3	27045-0003	G-9	39111-0023	E-3	42036-1190	E-8	482EA8000	G-4	49091-0001	F-8
224AA0445	G-7	27045-0010	F-10	39111-1174	D-10	42036-1376	E-7	482J5000	B-8	49093-0022	B-12
224AB0610	C-13	28012-1087	G-11	39112-0009	E-3	42036-1376	E-8	482J6000	C-8	49094-0019	B-13
23005-0006	G-7	311AB0500	G-3	39112-0010	E-3	43001-0092	F-6	49002-1097	B-3	49106-0048	B-6
23005-0007	G-7	312AB0600	F-11	39112-1079	D-10	43015-0036	F-8	49006-0007	D-8	49107-0050	B-6
23007-0024	G-7	315AA1000	D-10	39112-1080	B-11	43020-1054	F-8	49006-0008	D-8	49107-0065	B-6
23007-0025	G-7	318BA0800	B-6	39112-1084	D-10	43020-1101	F-9	49006-0021	D-8	49107-0066	B-6
23016-1182	E-5	318BA0800	D-10	39114-0006	E-3	43022-1010	F-8	49006-0062	D-5	49107-0067	B-6
23017-0001	G-7	32033-1535	C-8	39145-1121	D-10	43026-1074	F-8	49006-0063	D-5	49116-0021	C-5
23020-018	G-7	32097-0009	E-5	39145-1135	B-14	43028-1061	F-8	49006-0064	D-8	49118-0001	B-8
23025-0011	G-8	32160-0227	E-3	39152-0019	B-12	43034-1016	F-8	49006-0065	D-8	49118-0002	B-8
23026-1183	G-8	32190-0059	E-4	39152-0028	H-8	43045-1010	F-9	49006-0068	D-5	51001-0237	F-12
23026-1227	E-5	32190-0060	E-4	39183-0002	G-9	43049-1063	F-9	49006-1040	F-8	51044-0041	C-6
23058-002	E-5	34028-0054-6Z	E-9	39183-0003	E-5	43049-1064	F-9	49006-1088	F-9	51049-1128	F-12

This catalog covers:

'08~'09 KVF750 D8F/D9F

GRID NO.

L-14

This grid covers:

Numerical Parts Index

Part No.	Grid No.	Part No.	Grid No.	Part No.	Grid No.	Part No.	Grid No.	Part No.	Grid No.	Part No.	Grid No.
510A4200	C-9	56054-0095	G-14	56070-1286	G-13	92001-1728	F-8	92015-1415	E-8	92026-1599	B-10
52005-1082	G-12	56054-0096	G-14	56071-0036	G-13	92001-1980	B-9	92015-1432	B-11	92026-1600	B-10
53004-0002	E-5	56054-0096	H-3	56071-0073	G-13	92002-1323	F-8	92015-1432	D-10	92026-1603	B-12
53029-0054-16l	F-14	56054-0229	H-5	56071-0079	G-13	92002-1571	E-5	92015-1476	C-11	92026-1603	H-8
53029-0054-388	F-14	56054-0229	H-6	56071-0090	G-13	92002-1571	G-9	92015-1487	C-12	92026-1617	B-13
53029-0055-388	F-14	56054-0229	H-7	56071-0092	G-13	92002-1894	F-8	92015-1573	G-3	92027-1472	E-4
53029-0057-16l	F-14	56068-0357	G-14	59006-0015	B-5	92004-1217	B-3	92015-1596	F-10	92027-162	G-7
53029-0057-388	F-14	56068-0358	G-14	59011-0003	B-13	92005-1264	B-3	92015-1602	E-11	92027-162	G-8
53044-0037	E-11	56068-0411	G-14	59026-0005	C-9	92005-1369	C-4	92015-1602	E-11	92027-1847	F-12
53064-0002	E-11	56068-0412	G-14	59041-0002	C-12	92005-1387	B-14	92015-1602	E-12	92027-1964	G-6
53066-0196-MA	F-13	56068-0497	H-4	59071-3717	F-12	92009-1069	E-5	92015-1602	E-6	92028-1466	E-8
54005-0017	G-4	56068-0498	H-4	59256-1069	C-12	92009-1113	B-5	92015-1602	E-9	92028-1961	B-9
54005-0018	G-4	56068-0499	H-4	59266-0013	E-7	92009-1163	G-3	92015-1602	G-5	92028-1962	B-9
54010-0064	G-4	56068-0500	H-4	59266-0013	E-8	92009-1166	E-5	92015-1603	E-9	92028-1963	B-9
54012-0207	G-4	56068-0501	H-3	59266-0021	D-5	92009-1197	G-3	92015-1603	G-5	92028-1975	B-12
55020-0065	G-6	56068-0502	H-3	59266-0022	D-5	92009-1254	G-3	92015-1692	G-7	92028-1986	F-10
55020-0105	G-6	56068-0503	G-14	59266-0023	D-8	92009-1326	G-3	92015-1710	E-11	92033-1037	B-10
55020-0109-6Z	E-7	56068-0504	G-14	59266-1125	E-3	92009-1378	G-8	92015-1757	E-11	92033-1039	B-8
55020-0110-6Z	E-7	56068-1138	H-7	59301-0007	B-12	92009-1435	F-10	92015-1757	F-10	92033-1207	B-4
55020-0166-6Z	E-8	56068-1139	H-7	59302-0001	B-13	92009-1458	F-8	92015-1829	F-10	92033-1274	E-7
55020-0167-6Z	E-8	56068-1144	H-6	59302-0002	B-13	92009-1480	C-5	92016-061	B-7	92033-1317	B-13
55020-0247	C-10	56068-1145	H-6	59302-0003	B-12	92009-1480	E-8	92019-008	B-12	92037-1104	D-5
55020-0392	G-6	56068-1146	H-6	59416-0004	E-5	92009-1621	E-11	92019-008	G-8	92037-1104	D-8
55020-0426-6Z	G-6	56068-1147	H-6	59437-0001	E-8	92009-1621	E-11	92022-024	E-7	92037-1460	B-5
550AA2015	E-3	56068-1148	H-7	59441-0005-286	F-10	92009-1621	E-5	92022-024	E-8	92037-1461	F-12
550AA2015	F-6	56068-1149	H-7	59441-0005-290	F-10	92009-1621	G-5	92022-1049	F-6	92037-147	B-5
550AA2022	F-6	56068-1150	H-7	59441-0005-839	F-10	92009-1652	G-3	92022-1065	E-7	92037-147	C-4
550AA3025	E-3	56068-1151	H-7	59441-0006-6Z	F-10	92009-1654	F-10	92022-125	G-7	92037-1505	B-5
550AA3025	E-7	56068-1154	H-5	59502-0011	C-12	92009-1655	E-11	92022-1342	E-6	92037-1589	C-12
550AA4025	F-4	56068-1155	H-5	600A1000	B-11	92009-1655	G-5	92022-1346	G-5	92037-1712	C-12
550AA4025	F-5	56068-1156	H-5	600A1100	D-7	92009-1664	G-7	92022-1373	F-9	92037-1780	B-14
551A0408	C-13	56068-1157	H-5	601A6000	C-3	92009-1694	B-14	92022-1380	C-5	92037-1827	C-12
551A0408	C-8	56068-1162	H-6	601A6007	D-9	92009-1694	C-12	92022-1557	G-8	92037-1827	C-5
555A0428	D-9	56068-1163	H-6	601A6304	C-3	92009-1914	D-3	92022-1582	F-6	92037-1827	C-9
56007-0014	G-12	56068-1164	H-5	601A6305	D-7	92009-1914	D-5	92022-1720	B-3	92037-1827	G-9
56008-1007	G-12	56068-1165	H-5	670B2015	F-6	92009-1914	D-5	92022-1720	B-3	92037-1827	G-9
56019-120	G-12	56070-0037	G-13	670B2016	B-3	92009-1959	F-10	92022-1829	B-14	92037-2113	C-5
56030-0018	G-13	56070-0038	G-13	670D1505	C-8	92009-1961	F-10	92022-1829	E-7	92038-1051	H-8
56033-0064	G-13	56070-0039	G-13	670D1507	C-8	92009-1984	C-7	92022-237	B-6	92039-1229	E-12
56033-0078	C-3	56070-0041	F-14	670D2016	C-8	92009-1993	B-14	92022-276	B-6	92039-1229	F-12
56040-1321	F-14	56070-0045	G-13	670D2018	C-4	92013-009	B-7	92022-304	B-4	92039-1229	G-6
56052-0455	H-4	56070-0046	G-13	670D3022	B-14	92015-1094	E-5	92022-304	C-12	92039-1229	G-7
56052-0455	H-7	56070-1103	F-14	670D3022	D-7	92015-1094	G-7	92022-3742	E-3	92039-1260	E-13
56052-0947	G-14	56070-1108	G-13	670E5090	C-6	92015-1193	C-11	92026-0034	B-13	92039-3719	E-6
56052-0947	H-3	56070-1110	G-13	670E5090	C-6	92015-1233	F-8	92026-0038	H-8	92039-3763	E-13
56052-0947	H-5	56070-1110	G-13	671D25145	D-7	92015-1259	E-11	92026-1415	B-10	92039-3763	G-13
56052-0947	H-6	56070-1170	G-13	671D2530	B-13	92015-1311	B-9	92026-1415	B-10	92043-0083	D-5
56052-0947	H-6	56070-1253	F-14	671D2550	B-13	92015-1339	D-5	92026-1565	B-13	92043-076	C-8
56054-0092	H-4	56070-1266	G-13	671D2585	D-3	92015-1356	E-5	92026-1569	B-13	92043-1013	F-6
56054-0093	H-3	56070-1269	G-13	700Q0740	C-5	92015-1410	F-6	92026-1570	B-13	92043-1263	B-12
56054-0094	H-4	56070-1271	G-13	702A07035	C-4	92015-1415	E-7	92026-1587	B-10	92043-1263	B-3

This catalog covers:

'08~'09 KVF750 D8F/D9F

GRID NO.

This grid covers:

L-15 Numerical Parts Index

Part No.	Grid No.	Part No.	Grid No.	Part No.	Grid No.	Part No.	Grid No.	Part No.	Grid No.	Part No.	Grid No.
92043-1263	C-4	92049-1534	D-6	92066-1211	B-5	92093-1580	E-13	92145-1567	B-14	92153-0678	B-14
92043-1263	D-5	92049-1536	D-6	92066-1211	C-5	92104-0004	G-12	92150-1144	F-9	92153-0748	F-14
92043-1506	C-3	92049-1537	D-8	92066-1289	B-3	92104-1063	G-12	92150-1186	C-12	92153-0847	E-6
92043-1567	D-8	92049-1550	D-6	92066-1303	D-6	92107-005	G-12	92150-1302	B-3	92153-0870	D-6
92043-1575	D-5	92049-1570	C-3	92066-1303	D-8	92107-1053	G-12	92150-1384	E-7	92153-0870	D-9
92043-1617	D-8	92049-1572	D-6	92066-1580	B-14	92110-1116	G-12	92150-1624	E-8	92153-0871	E-4
92043-1688	B-12	92049-1573	D-6	92066-2196	B-7	92110-1129	G-12	92150-1686	E-7	92153-0872	E-4
92043-4009	B-3	92049-1575	C-3	92069-0005	G-7	92110-1140	G-12	92150-1800	F-9	92153-0930	E-4
92043-4009	B-4	92049-1576	C-4	92069-0006	G-7	92110-1152	G-12	92150-1884	D-6	92153-0931	F-14
92045-0012	C-3	92049-1578	F-10	92069-063	G-8	92110-1153	G-12	92150-1987	C-14	92153-0991	E-4
92045-0076	C-3	92049-7501	E-3	92069-085	E-6	92122-1209	B-13	92151-1392	F-4	92153-1052	B-5
92045-0077	D-8	92055-0016	C-7	92070-1209	C-10	92139-0084	F-7	92151-1392	F-5	92153-1065	E-3
92045-0078	D-8	92055-0112	B-3	92071-1128	G-9	92139-0215	B-12	92151-1393	B-12	92153-1129	F-11
92045-0084	C-4	92055-0122	D-6	92072-0033	E-6	92139-0215	H-8	92151-1686	B-14	92153-1139	F-7
92045-0086	C-4	92055-0122	D-8	92072-0095	E-11	92140-1064	D-8	92151-1687	B-11	92153-1200	B-8
92045-0091	C-3	92055-0136	C-11	92072-030	C-12	92143-1025	E-6	92151-1688	D-3	92153-1374	F-14
92045-0094	E-8	92055-086	B-8	92072-030	G-4	92143-1057	E-6	92151-1689	C-3	92153-1375	F-14
92045-0095	E-7	92055-1081	C-12	92072-030	G-9	92143-1057	E-9	92151-1699	B-11	92153-1502	E-4
92045-0099	D-8	92055-1136	C-3	92072-031	F-12	92143-1057	G-5	92151-1754	C-6	92153-1755	F-14
92045-0110	D-3	92055-1136	C-4	92072-031	G-9	92143-1057	G-7	92151-1781	C-8	92153-1850	C-11
92045-1190	C-3	92055-1146	C-4	92072-056	D-8	92143-1087	E-11	92151-1793	F-9	92153-1919	F-11
92045-1190	D-3	92055-1215	C-14	92072-056	F-12	92143-1087	E-11	92151-1794	D-6	92153-7007	C-14
92045-1207	D-3	92055-1276	C-11	92072-056	G-9	92143-1087	E-12	92151-1795	D-6	92160-1007	C-12
92045-1393	D-5	92055-1279	C-12	92072-1239	B-14	92143-1087	E-6	92151-1908	D-9	92160-1074	F-11
92045-1394	D-5	92055-1279	C-4	92072-1239	C-10	92143-1087	E-9	92151-1909	D-9	92160-1151	E-6
92046-0022	C-3	92055-1370	C-11	92072-1239	D-6	92143-1087	G-5	92151-1910	D-6	92160-1162	G-8
92046-0028	D-5	92055-1622	C-5	92072-1239	E-6	92143-1087	G-6	92151-1914	E-4	92160-1460	G-3
92046-1046	E-7	92055-1630	B-14	92072-1239	F-12	92143-1087	G-7	92151-1917	B-3	92160-1594	B-5
92046-1046	E-8	92055-1631	D-8	92072-1239	G-4	92143-1216	F-10	92151-1975	F-10	92161-0048	E-6
92046-1118	C-3	92055-1632	C-4	92072-1239	G-9	92143-1353	C-12	92152-0155	E-6	92161-0106	E-12
92046-1143	C-3	92055-1633	D-4	92072-3509	G-9	92143-1857	C-8	92152-0191	E-6	92161-0106	F-12
92046-1276	B-10	92055-1633	D-8	92075-1690	G-7	92143-1960	E-12	92152-0198	G-6	92161-0215	E-4
92046-1278	B-10	92055-1658	C-5	92075-1882	F-12	92144-1319	F-9	92152-0254	F-14	92161-0265	E-8
92046-1279	B-10	92055-1693	D-4	92075-209	C-12	92144-1674	C-5	92152-0255	F-14	92161-0319	B-6
92046-1280	D-8	92055-1693	D-8	92075-261	G-6	92145-0022	F-13	92152-0257	F-14	92161-0465	C-7
92046-1286	D-6	92055-1718	C-10	92081-112	C-8	92145-0130	D-10	92152-0423	B-6	92161-0572	E-6
92046-1297	D-6	92055-2185	C-4	92081-1896	G-7	92145-0144	F-6	92152-1176	F-11	92161-0586	E-11
92048-0002	C-11	92057-0073	B-8	92092-0004	E-8	92145-0557	B-12	92152-1222	D-10	92161-0618	E-6
92049-0028	D-8	92057-0074	B-8	92092-0007	F-7	92145-1297	B-11	92152-1332	B-14	92161-1111	F-12
92049-0029	D-8	92057-0075	C-8	92093-0016	B-14	92145-1299	B-11	92152-1349	D-6	92161-1114	G-3
92049-0095	D-3	92065-023	D-6	92093-0024	E-6	92145-1301	D-9	92152-1351	E-3	92161-1127	E-6
92049-1198	E-8	92065-023	D-8	92093-0028	E-6	92145-1303	B-8	92152-1455	E-7	92170-1448	B-3
92049-1218	B-7	92065-058	B-11	92093-0033	F-7	92145-1304	D-4	92152-1455	E-8	92170-1448	B-5
92049-1223	E-7	92065-097	C-3	92093-0038	E-13	92145-1304	D-9	92152-1467	C-14	92170-1497	C-12
92049-1223	E-8	92066-0011	C-4	92093-0082	C-5	92145-1313	F-6	92152-7501	E-3	92170-1514	B-5
92049-1228	C-4	92066-0012	C-4	92093-0083	B-5	92145-1344	D-6	92153-0311	D-9	92170-1514	C-9
92049-1271	B-11	92066-0036	E-6	92093-0118	E-11	92145-1392	F-10	92153-0574	G-6	92170-1514	G-8
92049-1452	C-3	92066-0095	B-3	92093-0127	C-5	92145-1421	F-6	92153-0574	G-7	92170-1764	B-14
92049-1458	D-10	92066-1077	F-10	92093-0136	E-11	92145-1429	F-10	92153-0627	F-8	92170-1925	C-9
92049-1528	B-13	92066-1174	C-3	92093-1548	B-14	92145-1499	B-13	92153-0666	E-8	92171-0081	G-9

This catalog covers:

'08~'09 KVF750 D8F/D9F

GRID NO.

L-16

This grid covers:

Numerical Parts Index

Part No.	Grid No.	Part No.	Grid No.	Part No.	Grid No.	Part No.	Grid No.	Part No.	Grid No.	Part No.	Grid No.
92171-0208	B-14	92180-1391	D-6	92192-0560	C-3	99947-1386	H-9				
92171-0223	E-11	92180-1392	D-6	92192-0572	E-6	99972-1109	H-9				
92171-0225	B-5	92180-1393	D-6	92192-0578	C-5	99972-1129	H-9				
92171-0228	G-4	92180-1394	D-6	92192-0716	D-7	99977-1280	H-9				
92171-0329	C-3	92180-1395	D-6	92200-0284	E-11	99977-1332	H-9				
92171-0378	F-11	92180-1396	D-6	92200-0364	B-5	99984-1084	H-9				
92171-0380	F-12	92180-1397	D-6	92200-0384	E-3	99984-1094	H-9				
92171-0476	G-9	92180-1398	D-6	92200-1240	B-10	99992-1048	H-9				
92171-0515	F-12	92180-1399	D-6	92200-1251	E-13	99992-1057	H-9				
92171-0722	B-3	92180-1400	D-6	92200-1251	G-13	99999-0055	E-11				
92171-0722	B-5	92180-1401	D-6	92200-1351	B-10						
92171-1185	C-5	92180-1402	D-6	92200-1504	B-12						
92171-1329	C-8	92180-1403	D-6	92200-1505	B-13						
92171-1330	B-6	92180-1404	D-6	92200-1508	B-7						
92171-1344	F-11	92180-1405	D-6	92200-1558	F-11						
92171-1423	G-9	92180-1406	D-6	92200-1559	F-11						
92171-1424	G-9	92180-1407	D-6	92200-1564	C-5						
92171-1438	C-5	92180-1408	D-6	92200-1595	E-14						
92171-1736	C-12	92180-1409	D-6	92200-1595	F-3						
92171-1741	F-12	92180-1410	D-6	92200-1634	B-12						
92171-7501	E-3	92180-1411	D-6	92200-1635	D-7						
92172-0002	E-12	92180-1412	D-7	92200-2035	B-6						
92172-0002	E-9	92180-1413	D-7	92210-0188	C-11						
92172-0002	G-5	92180-1414	D-7	92210-0276	E-8						
92172-0078	F-11	92180-1415	D-7	92210-0276	F-7						
92172-0156	C-5	92180-1416	D-7	92210-0335	C-12						
92172-0175	E-6	92180-1417	D-9	92210-0395	E-7						
92172-0297	B-5	92180-1418	D-9	92210-1081	E-4						
92172-0300	B-5	92180-1419	D-9	92210-1109	G-10						
92172-0341	D-9	92180-1420	D-9	92210-1150	E-4						
92172-0371	D-3	92180-1421	D-9	92210-1184	E-3						
92180-0161	D-9	92180-1422	D-9	92210-1225	D-7						
92180-0162	D-9	92180-1423	D-9	92210-1242	B-6						
92180-0163	D-9	92180-1424	D-9	92210-1242	D-10						
92180-0164	D-9	92180-1425	D-9	92210-1284	D-10						
92180-0165	D-9	92180-1426	D-9	92210-1294	D-3						
92180-0166	D-9	92180-1427	D-9	92210-1294	D-9						
92180-1307	D-3	92180-1428	D-9	92210-1325	E-14						
92180-1308	D-3	92191-1384	F-12	92210-1325	F-3						
92180-1309	D-3	92191-1531	B-5	92210-1331	E-6						
92180-1310	D-3	92192-0057	C-3	92210-1349	F-4						
92180-1311	D-3	92192-0067	F-12	92210-1351	D-7						
92180-1312	D-3	92192-0068	F-12	92210-1367	B-13						
92180-1313	D-3	92192-0128	F-12	92210-1381	F-5						
92180-1314	D-3	92192-0210	D-9	92210-1385	E-3						
92180-1349	D-3	92192-0436	C-3	92210-1386	E-3						
92180-1350	D-3	92192-0437	C-5	92210-7501	E-3						
92180-1351	D-3	92192-0439	C-5	99923-1619	H-9						
92180-1352	D-3	92192-0448	B-5	99923-1625	H-9						
92180-1390	D-6	92192-0449	B-5	99947-1380	H-9						

This catalog covers:

'08~'09 KVF750 D8F/D9F

GRID NO.

B-16

This grid covers:

Part Name Index

Air Cleaner.....	B-5
Brake Pedal.....	F-6
Cables.....	G-4
Camshaft(s).....	B-8
Carrier(s).....	F-14
Chassis Electrical Equipment.....	G-9
Control.....	D-10
Converter Cover.....	B-14
Crankcase.....	C-3
Crankshaft.....	B-9
Cylinder.....	B-4
Cylinder Head.....	B-3
Decals(Black)(D8F)(EU,UK).....	G-14
Decals(Black)(D9F)(EU,UK).....	H-5
Decals(L.Green)(D8F)(AS).....	H-4
Decals(L.Green)(D9F)(AS).....	H-7
Decals(W.Green)(D8F)(EU,UK).....	H-3
Decals(W.Green)(D9F)(EU,UK).....	H-6
Drive Belt.....	B-13
Drive Converter.....	B-12
Drive Shaft-Front.....	D-5/D-6/D-7
Drive Shaft-Propeller.....	D-4
Drive Shaft-Rear.....	D-8/D-9
Driven Converter.....	B-13
Engine Cover(s).....	C-4
Engine Mount.....	E-4
Flap.....	E-13
Footrests.....	E-9
Frame.....	E-3
Frame Fittings.....	E-5/E-6
Front Bevel Gear.....	D-3
Front Brake.....	F-9
Front Fender(s).....	E-10/E-11
Front Hub.....	F-4
Front Master Cylinder.....	F-8
Front Suspension.....	E-7

Fuel Injection.....	C-7
Fuel Pump.....	C-6
Fuel Tank.....	F-12
Gear Change Mechanism.....	B-11
Generator.....	C-9
Guard(s).....	G-6
Handlebar.....	F-10/F-11
Headlight(s).....	G-7
Ignition Switch.....	G-10
Ignition System.....	C-10
Labels.....	G-13
Manual(EU,UK).....	H-9
Meter(s).....	G-3
Muff er(s).....	B-6
Oil Pump.....	C-8
Optional Parts.....	H-8
Owner's Tools.....	G-12
Piston(s).....	B-4
Radiator.....	C-12/C-13
Rear Fender(s).....	E-12
Rear Hub.....	F-5
Rear Suspension.....	E-8
Recoil Starter.....	C-14
Re ctors.....	G-11
Seat.....	F-13
Shock Absorber(s).....	F-7
Side Covers.....	G-5
Starter Motor.....	C-11
Taillight(s).....	G-8
Tensioner.....	B-8
Throttle.....	C-5
Tires(D8F).....	E-14
Tires(D9F).....	F-3
Transmission.....	B-10
Valve(s).....	B-7

This catalog covers:

'08~'09 KVF750 D8F/D9F

GRID NO.

C-16

This grid covers:

Part Name Index

Air Cleaner.....	B-5
Brake Pedal.....	F-6
Cables.....	G-4
Camshaft(s).....	B-8
Carrier(s).....	F-14
Chassis Electrical Equipment.....	G-9
Control.....	D-10
Converter Cover.....	B-14
Crankcase.....	C-3
Crankshaft.....	B-9
Cylinder.....	B-4
Cylinder Head.....	B-3
Decals(Black)(D8F)(EU,UK).....	G-14
Decals(Black)(D9F)(EU,UK).....	H-5
Decals(L.Green)(D8F)(AS).....	H-4
Decals(L.Green)(D9F)(AS).....	H-7
Decals(W.Green)(D8F)(EU,UK).....	H-3
Decals(W.Green)(D9F)(EU,UK).....	H-6
Drive Belt.....	B-13
Drive Converter.....	B-12
Drive Shaft-Front.....	D-5/D-6/D-7
Drive Shaft-Propeller.....	D-4
Drive Shaft-Rear.....	D-8/D-9
Driven Converter.....	B-13
Engine Cover(s).....	C-4
Engine Mount.....	E-4
Flap.....	E-13
Footrests.....	E-9
Frame.....	E-3
Frame Fittings.....	E-5/E-6
Front Bevel Gear.....	D-3
Front Brake.....	F-9
Front Fender(s).....	E-10/E-11
Front Hub.....	F-4
Front Master Cylinder.....	F-8
Front Suspension.....	E-7

Fuel Injection.....	C-7
Fuel Pump.....	C-6
Fuel Tank.....	F-12
Gear Change Mechanism.....	B-11
Generator.....	C-9
Guard(s).....	G-6
Handlebar.....	F-10/F-11
Headlight(s).....	G-7
Ignition Switch.....	G-10
Ignition System.....	C-10
Labels.....	G-13
Manual(EU,UK).....	H-9
Meter(s).....	G-3
Muff er(s).....	B-6
Oil Pump.....	C-8
Optional Parts.....	H-8
Owner's Tools.....	G-12
Piston(s).....	B-4
Radiator.....	C-12/C-13
Rear Fender(s).....	E-12
Rear Hub.....	F-5
Rear Suspension.....	E-8
Recoil Starter.....	C-14
Re ctors.....	G-11
Seat.....	F-13
Shock Absorber(s).....	F-7
Side Covers.....	G-5
Starter Motor.....	C-11
Taillight(s).....	G-8
Tensioner.....	B-8
Throttle.....	C-5
Tires(D8F).....	E-14
Tires(D9F).....	F-3
Transmission.....	B-10
Valve(s).....	B-7

This catalog covers:

'08~'09 KVF750 D8F/D9F

GRID NO.

D-16

This grid covers:

Part Name Index

Air Cleaner.....	B-5
Brake Pedal.....	F-6
Cables.....	G-4
Camshaft(s).....	B-8
Carrier(s).....	F-14
Chassis Electrical Equipment.....	G-9
Control.....	D-10
Converter Cover.....	B-14
Crankcase.....	C-3
Crankshaft.....	B-9
Cylinder.....	B-4
Cylinder Head.....	B-3
Decals(Black)(D8F)(EU,UK).....	G-14
Decals(Black)(D9F)(EU,UK).....	H-5
Decals(L.Green)(D8F)(AS).....	H-4
Decals(L.Green)(D9F)(AS).....	H-7
Decals(W.Green)(D8F)(EU,UK).....	H-3
Decals(W.Green)(D9F)(EU,UK).....	H-6
Drive Belt.....	B-13
Drive Converter.....	B-12
Drive Shaft-Front.....	D-5/D-6/D-7
Drive Shaft-Propeller.....	D-4
Drive Shaft-Rear.....	D-8/D-9
Driven Converter.....	B-13
Engine Cover(s).....	C-4
Engine Mount.....	E-4
Flap.....	E-13
Footrests.....	E-9
Frame.....	E-3
Frame Fittings.....	E-5/E-6
Front Bevel Gear.....	D-3
Front Brake.....	F-9
Front Fender(s).....	E-10/E-11
Front Hub.....	F-4
Front Master Cylinder.....	F-8
Front Suspension.....	E-7

Fuel Injection.....	C-7
Fuel Pump.....	C-6
Fuel Tank.....	F-12
Gear Change Mechanism.....	B-11
Generator.....	C-9
Guard(s).....	G-6
Handlebar.....	F-10/F-11
Headlight(s).....	G-7
Ignition Switch.....	G-10
Ignition System.....	C-10
Labels.....	G-13
Manual(EU,UK).....	H-9
Meter(s).....	G-3
Muff er(s).....	B-6
Oil Pump.....	C-8
Optional Parts.....	H-8
Owner's Tools.....	G-12
Piston(s).....	B-4
Radiator.....	C-12/C-13
Rear Fender(s).....	E-12
Rear Hub.....	F-5
Rear Suspension.....	E-8
Recoil Starter.....	C-14
Re ctors.....	G-11
Seat.....	F-13
Shock Absorber(s).....	F-7
Side Covers.....	G-5
Starter Motor.....	C-11
Taillight(s).....	G-8
Tensioner.....	B-8
Throttle.....	C-5
Tires(D8F).....	E-14
Tires(D9F).....	F-3
Transmission.....	B-10
Valve(s).....	B-7

This catalog covers:

'08~'09 KVF750 D8F/D9F

GRID NO.

E-16

This grid covers:

Part Name Index

Air Cleaner.....	B-5
Brake Pedal.....	F-6
Cables.....	G-4
Camshaft(s).....	B-8
Carrier(s).....	F-14
Chassis Electrical Equipment.....	G-9
Control.....	D-10
Converter Cover.....	B-14
Crankcase.....	C-3
Crankshaft.....	B-9
Cylinder.....	B-4
Cylinder Head.....	B-3
Decals(Black)(D8F)(EU,UK).....	G-14
Decals(Black)(D9F)(EU,UK).....	H-5
Decals(L.Green)(D8F)(AS).....	H-4
Decals(L.Green)(D9F)(AS).....	H-7
Decals(W.Green)(D8F)(EU,UK).....	H-3
Decals(W.Green)(D9F)(EU,UK).....	H-6
Drive Belt.....	B-13
Drive Converter.....	B-12
Drive Shaft-Front.....	D-5/D-6/D-7
Drive Shaft-Propeller.....	D-4
Drive Shaft-Rear.....	D-8/D-9
Driven Converter.....	B-13
Engine Cover(s).....	C-4
Engine Mount.....	E-4
Flap.....	E-13
Footrests.....	E-9
Frame.....	E-3
Frame Fittings.....	E-5/E-6
Front Bevel Gear.....	D-3
Front Brake.....	F-9
Front Fender(s).....	E-10/E-11
Front Hub.....	F-4
Front Master Cylinder.....	F-8
Front Suspension.....	E-7

Fuel Injection.....	C-7
Fuel Pump.....	C-6
Fuel Tank.....	F-12
Gear Change Mechanism.....	B-11
Generator.....	C-9
Guard(s).....	G-6
Handlebar.....	F-10/F-11
Headlight(s).....	G-7
Ignition Switch.....	G-10
Ignition System.....	C-10
Labels.....	G-13
Manual(EU,UK).....	H-9
Meter(s).....	G-3
Muff er(s).....	B-6
Oil Pump.....	C-8
Optional Parts.....	H-8
Owner's Tools.....	G-12
Piston(s).....	B-4
Radiator.....	C-12/C-13
Rear Fender(s).....	E-12
Rear Hub.....	F-5
Rear Suspension.....	E-8
Recoil Starter.....	C-14
Re ctors.....	G-11
Seat.....	F-13
Shock Absorber(s).....	F-7
Side Covers.....	G-5
Starter Motor.....	C-11
Taillight(s).....	G-8
Tensioner.....	B-8
Throttle.....	C-5
Tires(D8F).....	E-14
Tires(D9F).....	F-3
Transmission.....	B-10
Valve(s).....	B-7

This catalog covers:

'08~'09 KVF750 D8F/D9F

GRID NO.

F-16

This grid covers:

Part Name Index

Air Cleaner.....	B-5
Brake Pedal.....	F-6
Cables.....	G-4
Camshaft(s).....	B-8
Carrier(s).....	F-14
Chassis Electrical Equipment.....	G-9
Control.....	D-10
Converter Cover.....	B-14
Crankcase.....	C-3
Crankshaft.....	B-9
Cylinder.....	B-4
Cylinder Head.....	B-3
Decals(Black)(D8F)(EU,UK).....	G-14
Decals(Black)(D9F)(EU,UK).....	H-5
Decals(L.Green)(D8F)(AS).....	H-4
Decals(L.Green)(D9F)(AS).....	H-7
Decals(W.Green)(D8F)(EU,UK).....	H-3
Decals(W.Green)(D9F)(EU,UK).....	H-6
Drive Belt.....	B-13
Drive Converter.....	B-12
Drive Shaft-Front.....	D-5/D-6/D-7
Drive Shaft-Propeller.....	D-4
Drive Shaft-Rear.....	D-8/D-9
Driven Converter.....	B-13
Engine Cover(s).....	C-4
Engine Mount.....	E-4
Flap.....	E-13
Footrests.....	E-9
Frame.....	E-3
Frame Fittings.....	E-5/E-6
Front Bevel Gear.....	D-3
Front Brake.....	F-9
Front Fender(s).....	E-10/E-11
Front Hub.....	F-4
Front Master Cylinder.....	F-8
Front Suspension.....	E-7

Fuel Injection.....	C-7
Fuel Pump.....	C-6
Fuel Tank.....	F-12
Gear Change Mechanism.....	B-11
Generator.....	C-9
Guard(s).....	G-6
Handlebar.....	F-10/F-11
Headlight(s).....	G-7
Ignition Switch.....	G-10
Ignition System.....	C-10
Labels.....	G-13
Manual(EU,UK).....	H-9
Meter(s).....	G-3
Muff er(s).....	B-6
Oil Pump.....	C-8
Optional Parts.....	H-8
Owner's Tools.....	G-12
Piston(s).....	B-4
Radiator.....	C-12/C-13
Rear Fender(s).....	E-12
Rear Hub.....	F-5
Rear Suspension.....	E-8
Recoil Starter.....	C-14
Re ctors.....	G-11
Seat.....	F-13
Shock Absorber(s).....	F-7
Side Covers.....	G-5
Starter Motor.....	C-11
Taillight(s).....	G-8
Tensioner.....	B-8
Throttle.....	C-5
Tires(D8F).....	E-14
Tires(D9F).....	F-3
Transmission.....	B-10
Valve(s).....	B-7

This catalog covers:

'08~'09 KVF750 D8F/D9F

GRID NO.

G-16

This grid covers:

Part Name Index

Air Cleaner.....	B-5
Brake Pedal.....	F-6
Cables.....	G-4
Camshaft(s).....	B-8
Carrier(s).....	F-14
Chassis Electrical Equipment.....	G-9
Control.....	D-10
Converter Cover.....	B-14
Crankcase.....	C-3
Crankshaft.....	B-9
Cylinder.....	B-4
Cylinder Head.....	B-3
Decals(Black)(D8F)(EU,UK).....	G-14
Decals(Black)(D9F)(EU,UK).....	H-5
Decals(L.Green)(D8F)(AS).....	H-4
Decals(L.Green)(D9F)(AS).....	H-7
Decals(W.Green)(D8F)(EU,UK).....	H-3
Decals(W.Green)(D9F)(EU,UK).....	H-6
Drive Belt.....	B-13
Drive Converter.....	B-12
Drive Shaft-Front.....	D-5/D-6/D-7
Drive Shaft-Propeller.....	D-4
Drive Shaft-Rear.....	D-8/D-9
Driven Converter.....	B-13
Engine Cover(s).....	C-4
Engine Mount.....	E-4
Flap.....	E-13
Footrests.....	E-9
Frame.....	E-3
Frame Fittings.....	E-5/E-6
Front Bevel Gear.....	D-3
Front Brake.....	F-9
Front Fender(s).....	E-10/E-11
Front Hub.....	F-4
Front Master Cylinder.....	F-8
Front Suspension.....	E-7

Fuel Injection.....	C-7
Fuel Pump.....	C-6
Fuel Tank.....	F-12
Gear Change Mechanism.....	B-11
Generator.....	C-9
Guard(s).....	G-6
Handlebar.....	F-10/F-11
Headlight(s).....	G-7
Ignition Switch.....	G-10
Ignition System.....	C-10
Labels.....	G-13
Manual(EU,UK).....	H-9
Meter(s).....	G-3
Muff er(s).....	B-6
Oil Pump.....	C-8
Optional Parts.....	H-8
Owner's Tools.....	G-12
Piston(s).....	B-4
Radiator.....	C-12/C-13
Rear Fender(s).....	E-12
Rear Hub.....	F-5
Rear Suspension.....	E-8
Recoil Starter.....	C-14
Re ctors.....	G-11
Seat.....	F-13
Shock Absorber(s).....	F-7
Side Covers.....	G-5
Starter Motor.....	C-11
Taillight(s).....	G-8
Tensioner.....	B-8
Throttle.....	C-5
Tires(D8F).....	E-14
Tires(D9F).....	F-3
Transmission.....	B-10
Valve(s).....	B-7

This catalog covers:

'08~'09 KVF750 D8F/D9F

GRID NO.

H-16

This grid covers:

Part Name Index

Air Cleaner.....	B-5
Brake Pedal.....	F-6
Cables.....	G-4
Camshaft(s).....	B-8
Carrier(s).....	F-14
Chassis Electrical Equipment.....	G-9
Control.....	D-10
Converter Cover.....	B-14
Crankcase.....	C-3
Crankshaft.....	B-9
Cylinder.....	B-4
Cylinder Head.....	B-3
Decals(Black)(D8F)(EU,UK).....	G-14
Decals(Black)(D9F)(EU,UK).....	H-5
Decals(L.Green)(D8F)(AS).....	H-4
Decals(L.Green)(D9F)(AS).....	H-7
Decals(W.Green)(D8F)(EU,UK).....	H-3
Decals(W.Green)(D9F)(EU,UK).....	H-6
Drive Belt.....	B-13
Drive Converter.....	B-12
Drive Shaft-Front.....	D-5/D-6/D-7
Drive Shaft-Propeller.....	D-4
Drive Shaft-Rear.....	D-8/D-9
Driven Converter.....	B-13
Engine Cover(s).....	C-4
Engine Mount.....	E-4
Flap.....	E-13
Footrests.....	E-9
Frame.....	E-3
Frame Fittings.....	E-5/E-6
Front Bevel Gear.....	D-3
Front Brake.....	F-9
Front Fender(s).....	E-10/E-11
Front Hub.....	F-4
Front Master Cylinder.....	F-8
Front Suspension.....	E-7

Fuel Injection.....	C-7
Fuel Pump.....	C-6
Fuel Tank.....	F-12
Gear Change Mechanism.....	B-11
Generator.....	C-9
Guard(s).....	G-6
Handlebar.....	F-10/F-11
Headlight(s).....	G-7
Ignition Switch.....	G-10
Ignition System.....	C-10
Labels.....	G-13
Manual(EU,UK).....	H-9
Meter(s).....	G-3
Muff er(s).....	B-6
Oil Pump.....	C-8
Optional Parts.....	H-8
Owner's Tools.....	G-12
Piston(s).....	B-4
Radiator.....	C-12/C-13
Rear Fender(s).....	E-12
Rear Hub.....	F-5
Rear Suspension.....	E-8
Recoil Starter.....	C-14
Re ctors.....	G-11
Seat.....	F-13
Shock Absorber(s).....	F-7
Side Covers.....	G-5
Starter Motor.....	C-11
Taillight(s).....	G-8
Tensioner.....	B-8
Throttle.....	C-5
Tires(D8F).....	E-14
Tires(D9F).....	F-3
Transmission.....	B-10
Valve(s).....	B-7