2009 Polaris Sportsman 850 EFi/HD/EPS series

Some models may need supplemental manuals which have blue titles. Use the base manual for everything not contained in the supplement if your model or year requires a supplement.

If you bought this manual from any other seller, they are reselling my work.

Please leave them negative feedback & email me at sales@midwestmanuals.com.

Our goal is to be one of the BEST sellers on eBay and the internet by providing you with the BEST customer service and the BEST manuals on the market.

Thank you for choosing us.



GENERAL INFORMATION

VEHICLE IDENTIFICATION 1.2
 MODEL IDENTIFICATION 1.2
 ENGINE DESIGNATION NUMBER 1.2
 VEHICLE IDENTIFICATION NUMBER (VIN) 1.2
 VEHICLE AND ENGINE SERIAL NUMBER LOCATIONS 1.2
VEHICLE INFORMATION 1.3
 PUBLICATION NUMBERS 1.3
 REPLACEMENT KEYS 1.3
 SPECIAL TOOLS 1.3
SPECIFICATIONS 1.4
 GENERAL: 2009 SPORTSMAN XP 850 1.4
 GENERAL: 2009 SPORTSMAN XP 850 EPS 1.4
 DETAILED: 2009 SPORTSMAN XP 850 / XP 850 EPS 1.5
MISC. SPECIFICATIONS AND CHARTS 1.6
 CONVERSION TABLE 1.6
 STANDARD TORQUE SPECIFICATIONS 1.7
 SAE TAP / DRILL SIZES 1.8
 METRIC TAP / DRILL SIZES 1.8
 DECIMAL EQUIVALENTS 1.8
 GLOSSARY OF TERMS 1.9



sales@midwestmanuals.com

www.midwestmanuals.com

GENERAL INFORMATION

VEHICLE IDENTIFICATION

Model Identification

The machine model number must be used with any correspondence regarding warranty or service.

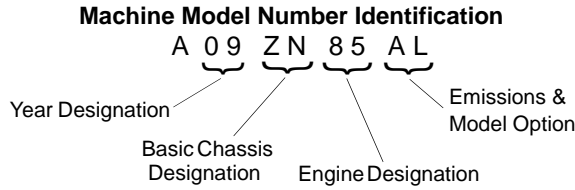

Engine Designation Number

EH085OLE.....Twin Cylinder, 4-Cycle SOHC, Liquid Cooled, Electric Start

Vehicle Identification Number (VIN)

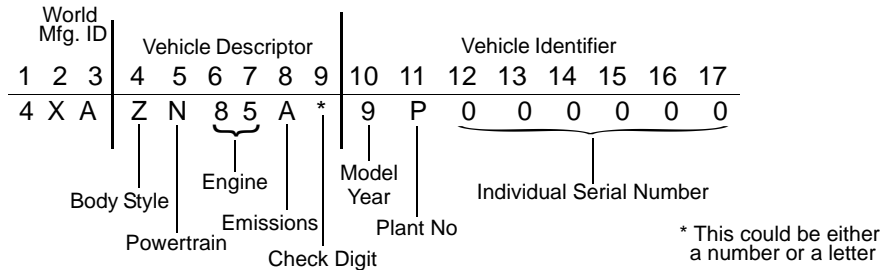

Vehicle and Engine Serial Number Locations

Whenever corresponding about a Polaris ATV, be sure to refer to the vehicle identification number (VIN) and the engine serial number.

The VIN can be found stamped on the lower frame rail on the front LH side of the ATV (see Figure 1-1).

The engine serial number can be found on top of the engine located on the valve cover (see Figure 1-2).

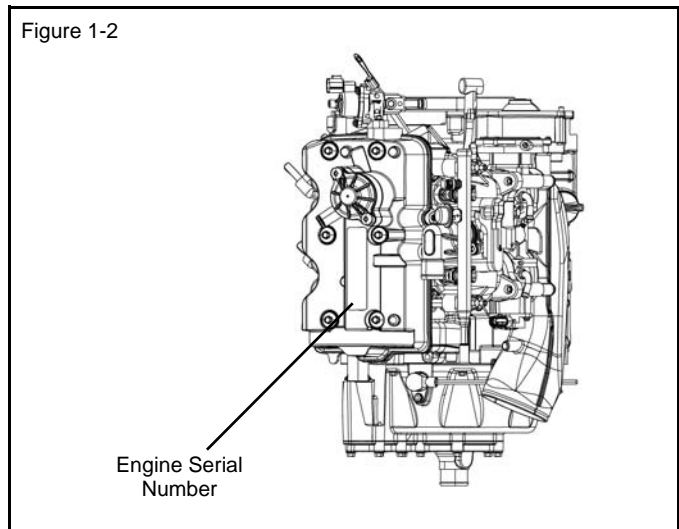
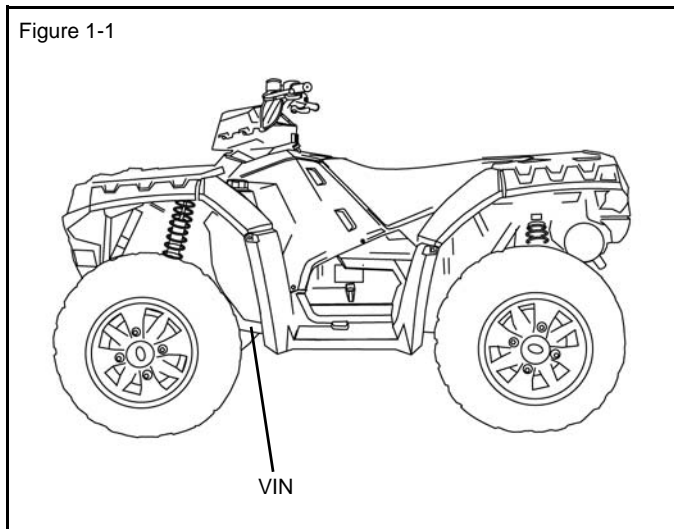

VEHICLE INFORMATION**Publication Numbers**

YEAR	MODEL	MODEL NO.	OWNER'S MANUAL PN	PARTS MANUAL PN
2009	SPORTSMAN XP 850	A09ZN85AL, AQ, AS, AT, AX, FL	9921854	9921857
2009	SPORTSMAN XP 850 EPS	A09ZX85AG, AL, AQ, AR, AS, AX, FS	9921976	9921977

NOTE: Additional Polaris factory publications can be found at www.polarisindustries.com or purchased from www.purepolaris.com.

Replacement Keys

Replacement keys can be made from the original key. To identify which series the key is, take the first two digits on the original key and refer to the chart to the right for the proper part number. Should both keys become lost, replacement of the ignition switch assembly is necessary.

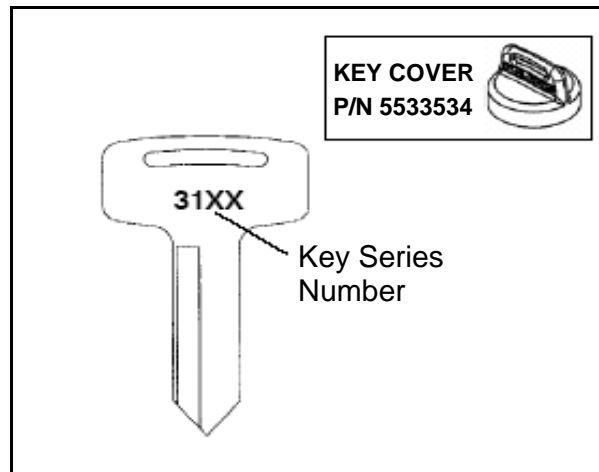

Series #	Part Number
20	4010278
21	4010278
22	4010321
23	4010321
27	4010321
28	4010321
31	4110141
32	4110148
67	4010278
68	4010278

Special Tools

Special tools may be required while servicing this vehicle. Some of the tools listed or depicted are mandatory, while other tools maybe substituted with a similar tool, if available. Polaris recommends the use of Polaris Special Tools when servicing any Polaris product. Dealers may order special tools through Polaris' official tool supplier, SPX Corporation, by phone at 1-800-328-6657 or on-line at <http://polaris.spx.com/>.

GENERAL INFORMATION

SPECIFICATIONS

MODEL: 2009 SPORTSMAN XP 850

MODEL NUMBER: A09ZN85AL, AQ, AS, AT, AX, FL

ENGINE MODEL: EH085OLE

Category	Dimension
Length	83.25 in. / 211.5 cm
Width	47.6 in. / 121 cm
Height	50.75 in. / 129 cm
Wheel Base	53 in. / 135 cm
Ground Clearance	11.6 in. / 29.5 cm
Turning Radius	84 in. / 213 cm (unloaded)
Dry Weight	784 lbs. / 356 kg
Front Rack Capacity	120 lbs. / 54 kg
Rear Rack Capacity	240 lbs. / 109 kg
Max. Weight Capacity	575 lbs. / 261 kg
Towing Capacity	1500 lbs. / 680 kg
Hitch Tongue Weight	150 lbs. / 68 kg



MODEL: 2009 SPORTSMAN XP 850 EPS

MODEL NUMBER: A09ZX85AG, AL, AQ, AR, AS, AX, FS

ENGINE MODEL: EH085OLE

Category	Dimension
Length	83.25 in. / 211.5 cm
Width	47.6 in. / 121 cm
Height	50.75 in. / 129 cm
Wheel Base	53 in. / 135 cm
Ground Clearance	11.6 in. / 29.5 cm
Turning Radius	84 in. / 213 cm (unloaded)
Dry Weight	796 lbs. / 361 kg
Front Rack Capacity	120 lbs. / 54 kg
Rear Rack Capacity	240 lbs. / 109 kg
Max. Weight Capacity	575 lbs. / 261 kg
Towing Capacity	1500 lbs. / 680 kg
Hitch Tongue Weight	150 lbs. / 68 kg



2009 SPORTSMAN XP 850 / XP 850 EPS

XP MODELS: A09ZN85AL,AQ,AS,AT,AX,FL
XP EPS MODELS: A09ZX85AG,AL,AQ,AR,AS,AX,FS
ENGINE MODEL: EH085OLE

Engine	
Platform	Domestic Twin Cylinder, 4-Cycle
Engine Model Number	EH085OLE011
Engine Displacement	850 cc
Number of Cylinders	2
Bore & Stroke (mm)	87 x 71.5 mm
Compression Ratio	11.0:1
Compression Pressure	210 - 250 psi
Engine Idle Speed	1200 ± 50 RPM
Cooling System / Cap.	Liquid Cooled / 2 qt. (1.9 l)
Overheat Warning	Instrument Cluster Indicator
Lubrication	Pressurized Wet Sump
Engine Oil Requirement	PS-4 Plus / 2 qt. (1.9 l)
Exhaust System	Stainless Steel Dual Header Pipe w/ Dual Outlet Silencer
Fuel System	
Fuel System Type	Bosch Multi-Port Sequential Electronic Fuel Injection
Throttle Body / Size	Mikuni Dual Bore / 40 mm
Fuel Delivery	Electronic Fuel Pump (in tank)
Fuel Pressure	43 psi
Fuel Capacity	XP: 5.25 gal. (20 l) XP EPS: 4.5 gal. (17 l)
Fuel Requirements	87 Octane (minimum)
Electrical	
Alternator Output	475 W @ 1200 RPM / Peak 575 W
Voltage Regulator	3-Phase / 32 Amp
Head Lights	Pod: 12V / 50 Watts Bumper: 12V / 50 Watts x 2
Brake Light	12V / 27 Watts
Tail Light	12V / 7 Watts
Starting System	Electric
Ignition System	Bosch EFI (ECU Controlled)
Ignition Timing	6° ± 5° BTDC @ 1200 RPM
Spark plug / Gap	REA8MCL / .035 in. (.90 mm)
Battery / Model / AH / CCA	Deka / ETX30L / 30 AH / 365
Instrumentation	Multifunction Instrument Cluster
DC Outlet	Standard
Relays (Located in Relay/Fuse Box)	Chassis / Start Solenoid / Fan / EFI / Bumper Lights
Circuit Breaker	Fan Motor: 20A
Fuses (Located in Relay/Fuse Box)	Lights: 20A / Drive: 20A / Accessory: 20A / EFI: 20A / Unswitched: 10A / EPS: 30A

Drivetrain	
Transmission Type	Automatic PVT In-Line H-L-N-R-P
Transmission Fluid Type / Fluid Capacity	Synthetic Sportsman XP Transmission Fluid / 32 oz. (946 ml)
Front Gearcase Fluid Type / Fluid Capacity	Premium LT Demand Drive Fluid / 9.3 oz. (275 ml)
Front Gearcase ADC Reservoir Fluid Type	Premium ADC Front Drive Fluid
Rear Gearcase Fluid Type / Fluid Capacity	ATV Angle Drive Fluid / 7.1 oz. (210 ml)
Clutch Type	PVT w/EBS
Belt	3211123
Steering / Suspension	
Toe Out	0-1/16 in. (0-.159 mm)
Front Suspension	Dual A-arm
Front Travel	9.2 in. / 23.4 cm
Rear Suspension	Dual A-arm w/Rolled IRS
Rear Travel	10.2 in. / 25.9 cm
Shock Preload Adjustment Front / Rear	Cam Adjustable
Wheels / Brakes	
Front Wheel Size / Bolt Pattern	14 x 6 / 4-156
Tire Model / Size	Carlisle Terrathon / 26 x 8 - 14
Rear Wheel Size / Bolt Pattern	14 x 8 / 4-156
Tire Model / Size	Carlisle Terrathon / 26 x 10 - 14
Tire Air Pressure	Front: 7 psi (48 kPa) Rear: 5 psi (34.5 kPa)
Brakes - Front & Rear	Single Control Hydraulic 4-Wheel Disc
Brake Fluid	Polaris DOT 4 Brake Fluid

CLUTCH CHART

Altitude		Shift Weight	Drive Spring	Driven Spring
Meters (Feet)	0-1800 (0-6000)	24-63 5632215	Red / Wht 7043349	Red / Wht 3235621
	1800-3700 (6000 - 12000)	24-60 5632216	Red / Wht 7043349	Red / Wht 3235621

GENERAL INFORMATION**MISC. SPECIFICATIONS AND CHARTS****Conversion Table**

Unit of Measure	Multiplied by	Converts to
ft. lbs.	x 12	= in. lbs.
in. lbs.	x .0833	= ft. lbs.
ft. lbs.	x 1.356	= Nm
in. lbs.	x .0115	= kg-m
Nm	x .7376	= ft.lbs.
kg-m	x 7.233	= ft. lbs.
kg-m	x 86.796	= in. lbs.
kg-m	x 10	= Nm
in.	x 25.4	=mm
mm	x .03937	= in.
in.	x 2.54	= cm
mile (mi.)	x 1.6	= km
km	x .6214	= mile (mi.)
Ounces (oz)	x 28.35	= Grams (g)
Fluid Ounces (fl. oz.)	x 29.57	= Cubic Centimeters (cc)
Cubic Centimeters (cc)	x .03381	= Fluid Ounces (fl. oz.)
Grams (g)	x 0.035	= Ounces (oz)
lb.	x .454	= kg
kg	x 2.2046	= lb.
Cubic inches (cu in)	x 16.387	= Cubic centimeters (cc)
Cubic centimeters (cc)	x 0.061	= Cubic inches (cu in)
Imperial pints (Imp pt)	x 0.568	= Liters (l)
Liters (l)	x 1.76	= Imperial pints (Imp pt)
Imperial quarts (Imp qt)	x 1.137	= Liters (l)
Liters (l)	x 0.88	= Imperial quarts (Imp qt)
Imperial quarts (Imp qt)	x 1.201	= US quarts (US qt)
US quarts (US qt)	x 0.833	= Imperial quarts (Imp qt)
US quarts (US qt)	x 0.946	= Liters (l)
Liters (l)	x 1.057	= US quarts (US qt)
US gallons (US gal)	x 3.785	=Liters (l)
Liters (l)	x 0.264	= US gallons (US gal)
Pounds - force per square inch (psi)	x 6.895	= Kilopascals (kPa)
Kilopascals (kPa)	x 0.145	= Pounds - force per square inch (psi)
Kilopascals (kPa)	x 0.01	= Kilograms - force per square cm
Kilograms - force per square cm	x 98.1	= Kilopascals (kPa)
$\pi (3.14) \times R^2 \times H$ (height)		= Cylinder Volume

$$^{\circ}\text{C to }^{\circ}\text{F: } \frac{9}{5}(^{\circ}\text{C} + 32) = ^{\circ}\text{F}$$

$$^{\circ}\text{F to }^{\circ}\text{C: } \frac{5}{9}(^{\circ}\text{F} - 32) = ^{\circ}\text{C}$$

Standard Torque Specifications

The following torque specifications are to be used only as a general guideline. There are exceptions in the steering, suspension, and engine areas. Always consult the exploded views or each manual section for torque values of fasteners before using standard torque.

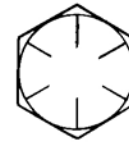
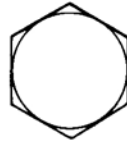

Bolt Size	Threads/In	Grade 2	Grade 5	Grade 8
		<u>Torque in. lbs. (Nm)</u>		
#10	- 24	27 (3.1)	43 (5.0)	60 (6.9)
#10	- 32	31 (3.6)	49 (5.6)	68 (7.8)
<u>Torque ft. lbs. (Nm)*</u>				
1/4	- 20	5 (7)	8 (11)	12 (16)
1/4	- 28	6 (8)	10 (14)	14 (19)
5/16	- 18	11 (15)	17 (23)	25 (35)
5/16	- 24	12 (16)	19 (26)	29 (40)
3/8	- 16	20 (27)	30 (40)	45 (62)
3/8	- 24	23 (32)	35 (48)	50 (69)
7/16	- 14	30 (40)	50 (69)	70 (97)
7/16	- 20	35 (48)	55 (76)	80 (110)
1/2	- 13	50 (69)	75 (104)	110 (152)
1/2	- 20	55 (76)	90 (124)	120 (166)

Metric

- 6 x 1.0 72-78 In. lbs.
- 8 x 1.25 14-18 ft. lbs.
- 10 x 1.25 26-30 ft. lbs.

*To convert ft. lbs. to Nm multiply foot pounds by 1.382

*To convert Nm to ft. lbs. multiply Nm by .7376.

SPECIFIC TORQUE VALUES OF FASTENERS

Refer to exploded views in the appropriate section.

GENERAL INFORMATION

SAE Tap / Drill Sizes

Thread Size/Drill Size		Thread Size/Drill Size	
#0-80	3/64	1/2-13	27/64
#1-64	53	1/2-20	29/64
#1-72	53	9/16-12	31/64
#2-56	51	9/16-18	33/64
#2-64	50	5/8-11	17/32
#3-48	5/64	5/8-18	37/64
#3-56	45	3/4-10	21/32
#4-40	43	3/4-16	11/16
#4-48	42	7/8-9	49/64
#5-40	38	7/8-14	13/16
#5-44	37	1-8	7/8
#6-32	36	1-12	59/64
#6-40	33	1 1/8-7	63/64
#8-32	29	1 1/8-12	1 3/64
#8-36	29	1 1/4-7	1 7/64
#10-24	24	1 1/4-12	1 11/64
#10-32	21	1 1/2-6	1 11/32
#12-24	17	1 1/2-12	1 27/64
#12-28	4.6mm	1 3/4-5	1 9/16
1/4-20	7	1 3/4-12	1 43/64
1/4-28	3	2-4 1/2	1 25/32
5/16-18	F	2-12	1 59/64
5/16-24	I	2 1/4-4 1/2	2 1/32
3/8-16	O	2 1/2-4	2 1/4
3/8-24	Q	2 3/4-4	2 1/2
7/16-14	U	3-4	2 3/4
7/16-20	25/64		

Decimal Equivalents

1/64	.0156	
1/32	.0312	1 mm = .0394"
3/64	.0469	
1/16	.0625	
5/64	.0781	2 mm = .0787"
3/32	.0938	
7/64	.1094	3 mm = .1181"
1/8	.1250	
9/64	.1406	
5/32	.1563	4 mm = .1575"
11/64	.1719	
3/16	.1875	5 mm = .1969"
13/64	.2031	
7/32	.2188	
15/64	.2344	6 mm = .2362"
1/4	.25	
17/64	.2656	7 mm = .2756"
9/32	.2813	
19/64	.2969	
5/16	.3125	8 mm = .3150"
21/64	.3281	
11/32	.3438	9 mm = .3543"
23/64	.3594	
3/8	.375	
25/64	.3906	10 mm = .3937"
13/32	.4063	
27/64	.4219	11 mm = .4331"
7/16	.4375	
29/64	.4531	
15/32	.4688	12 mm = .4724"
31/64	.4844	
1/2	.5	13 mm = .5118
33/64	.5156	
17/32	.5313	
35/64	.5469	14 mm = .5512"
9/16	.5625	
37/64	.5781	15 mm = .5906"
19/32	.5938	
39/64	.6094	
5/8	.625	16 mm = .6299"
41/64	.6406	
21/32	.6563	17 mm = .6693"
43/64	.6719	
11/16	.6875	
45/64	.7031	18 mm = .7087"
23/32	.7188	
47/64	.7344	19 mm = .7480"
3/4	.75	
49/64	.7656	
25/32	.7813	20 mm = .7874"
51/64	.7969	
13/16	.8125	21 mm = .8268"
53/64	.8281	
27/32	.8438	
55/64	.8594	22 mm = .8661"
7/8	.875	
57/64	.8906	23 mm = .9055"
29/32	.9063	
59/64	.9219	
15/16	.9375	24 mm = .9449"
61/64	.9531	
31/32	.9688	25 mm = .9843
63/64	.9844	
1	1.0	

Metric Tap / Drill Sizes

Tap Size	Drill Size	Decimal Equivalent	Nearest Fraction
3 x .50	#39	0.0995	3/32
3 x .60	3/32	0.0937	3/32
4 x .70	#30	0.1285	1/8
4 x .75	1/8	0.125	1/8
5 x .80	#19	0.166	11/64
5 x .90	#20	0.161	5/32
6 x 1.00	#9	0.196	13/64
7 x 1.00	16/64	0.234	15/64
8 x 1.00	J	0.277	9/32
8 x 1.25	17/64	0.265	17/64
9 x 1.00	5/16	0.3125	5/16
9 x 1.25	5/16	0.3125	5/16
10 x 1.25	11/32	0.3437	11/32
10 x 1.50	R	0.339	11/32
11 x 1.50	3/8	0.375	3/8
12 x 1.50	13/32	0.406	13/32
12 x 1.75	13/32	0.406	13/32

Glossary of Terms

ABDC: After bottom dead center.

ACV: Alternating current voltage.

Alternator: Electrical generator producing voltage alternating current.

ATDC: After top dead center.

BBDC: Before bottom dead center.

BDC: Bottom dead center.

BTDC: Before top dead center.

CC: Cubic centimeters.

Center Distance: Distance between center of crankshaft and center of driven clutch shaft.

Chain Pitch: Distance between chain link pins (No. 35 = 3/8" or 1 cm). Polaris measures chain length in number of pitches.

CI: Cubic inches.

Clutch Buttons: Plastic bushings which aid rotation of the movable sheave in the drive and driven clutch.

Clutch Offset: Drive and driven clutches are offset so that drive belt will stay nearly straight as it moves along the clutch face.

Clutch Weights: Three levers in the drive clutch which relative to their weight, profile and engine RPM cause the drive clutch to close and grip the drive belt.

Crankshaft Run-Out: Run-out or "bend" of crankshaft measured with a dial indicator while crankshaft is supported between centers on V blocks or resting in crankcase. Measure at various points especially at PTO.

DCV: Direct current voltage

CVT: Centrifugal Variable Transmission (Drive Clutch System)

DCV: Direct current voltage.

Dial Bore Gauge: A cylinder measuring instrument which uses a dial indicator. Good for showing taper and out-of-round in the cylinder bore.

Electrical Open: Open circuit. An electrical circuit which isn't complete.

Electrical Short: Short circuit. An electrical circuit which is completed before the current reaches the intended load. (i.e. a bare wire touching the chassis).

End Seals: Rubber seals at each end of the crankshaft.

Engagement RPM: Engine RPM at which the drive clutch engages to make contact with the drive belt.

ft.: Foot/feet.

Foot Pound: Ft. lb. A force of one pound at the end of a lever one foot in length, applied in a rotational direction.

g: Gram. Unit of weight in the metric system.

gal.: Gallon.

ID: Inside diameter.

in.: Inch/inches.

Inch Pound: In. lb. 12 in. lbs. = 1 ft. lb.

kg/cm²: Kilograms per square centimeter.

kg-m: Kilogram meters.

Kilogram/meter: A force of one kilogram at the end of a lever one meter in length, applied in a rotational direction.

l or ltr: Liter.

lbs/in²: Pounds per square inch.

Left or Right Side: Always referred to based on normal operating position of the driver.

m: Meter/meters.

Mag: Magneto.

Magnetic Induction: As a conductor (coil) is moved through a magnetic field, a voltage will be generated in the windings. Mechanical energy is converted to electrical energy in the stator.

mi.: Mile/miles.

mm: Millimeter. Unit of length in the metric system. 1 mm = approximately .040".

Nm: Newton meters.

OD: Outside diameter.

Ohm: The unit of electrical resistance opposing current flow.

oz.: Ounce/ounces.

Piston Clearance: Total distance between piston and cylinder wall.

psi.: Pounds per square inch.

PTO: Power take off.

PVT: Polaris Variable Transmission (Drive Clutch system)

qt.: Quart/quarts.

Regulator: Voltage regulator. Regulates battery charging system output at approx. 14.5 DCV as engine RPM increases.

Reservoir Tank: The fill tank in the liquid cooling system.

Resistance: In the mechanical sense, friction or load. In the electrical sense, ohms, resulting in energy conversion to heat.

RPM: Revolutions per minute.

Seized Piston: Galling of the sides of a piston. Usually there is a transfer of aluminum from the piston onto the cylinder wall.

Possible causes: 1) improper lubrication; 2) excessive temperatures; 3) insufficient piston clearance; 4) stuck piston rings.

Stator Plate: The plate mounted under the flywheel supporting the battery charging coils.

TDC: Top dead center. Piston's most outward travel from crankshaft.

Volt: The unit of measure for electrical pressure of electromotive force. Measured by a voltmeter in parallel with the circuit.

Watt: Unit of electrical power. Watts = amperes x volts.

WOT: Wide open throttle.

CHAPTER 2

MAINTENANCE

2

PERIODIC MAINTENANCE CHART	2.2
BREAK-IN PERIOD / MAINTENANCE CHART KEY	2.2
MAINTENANCE INTERVALS	2.3
GREASE LUBRICATION POINTS	2.5
MAINTENANCE QUICK REFERENCE	2.6
MAINTENANCE QUICK REFERENCE, CONTINUED.....	2.7
LUBRICANTS / SERVICE PRODUCTS	2.8
GENERAL VEHICLE INSPECTION AND MAINTENANCE.....	2.9
FUEL SYSTEM AND AIR INTAKE	2.9
FUEL LINES	2.9
FUEL FILTERS / VENT LINE	2.10
THROTTLE OPERATION / ETC SWITCH / THROTTLE CABLE ADJUSTMENT	2.10
AIR FILTER / PRE-FILTER SERVICE	2.11
ENGINE	2.12
ENGINE OIL LEVEL / OIL AND FILTER CHANGE	2.12
ENGINE BREATHER HOSE / BREATHER ASSEMBLY	2.13
VALVE CLEARANCE ADJUSTMENT	2.14
COMPRESSION AND LEAKDOWN TESTS	2.15
EXHAUST SILENCER CLEANING.....	2.16
ENGINE MOUNT FASTENER TORQUE	2.16
TRANSMISSION AND GEARCASES	2.17
TRANSMISSION LUBRICATION	2.17
FRONT GEARCASE LUBRICATION	2.18
FRONT GEARCASE ADC FLUID.....	2.19
REAR GEARCASE LUBRICATION	2.20
COOLING SYSTEM.....	2.21
COOLANT LEVEL INSPECTION	2.21
COOLING SYSTEM HOSES / COOLANT STRENGTH / COOLANT TYPE	2.22
PVT / FINAL DRIVE / WHEEL AND TIRE	2.23
PVT DRYING / DRIVE BELT REMOVAL	2.23
DRIVE SHAFT BOOT INSPECTION	2.23
WHEEL AND HUB TORQUE TABLE	2.24
WHEEL REMOVAL / INSTALLATION	2.24
TIRE PRESSURE / TIRE INSPECTION.....	2.25
ELECTRICAL AND IGNITION SYSTEM	2.25
BATTERY MAINTENANCE	2.25
BATTERY REMOVAL / INSTALLATION	2.26
SPARK PLUG SERVICE	2.26
ENGINE / CHASSIS GROUND	2.27
STEERING	2.28
STEERING INSPECTION.....	2.28
POWER STEERING UNIT (EPS MODELS).....	2.28
TIE ROD END / STEERING INSPECTION / TOE ALIGNMENT	2.29
TOE ALIGNMENT ADJUSTMENT	2.30
SUSPENSION	2.30
SUSPENSION INSPECTION / SUSPENSION SPRING PRE-LOAD ADJUSTMENT ..	2.30
BRAKE SYSTEM.....	2.31
BRAKE FLUID / BRAKE PAD / HOSE / FITTING INSPECTION	2.31
AUXILIARY BRAKE PEDAL.....	2.32
MAINTENANCE LOG	2.33

MAINTENANCE

PERIODIC MAINTENANCE CHART

Periodic Maintenance Overview

Inspection, adjustment and lubrication of important components are explained in the periodic maintenance chart.

Inspect, clean, lubricate, adjust and replace parts as necessary. When inspection reveals the need for replacement parts, use genuine Pure Polaris parts available from your Polaris dealer.

NOTE: Service and adjustments are critical. If you're not familiar with safe service and adjustment procedures, have a qualified dealer perform these operations.

Maintenance intervals in the following chart are based upon average riding conditions and an average vehicle speed of approximately 10 miles per hour. Vehicles subjected to severe use must be inspected and serviced more frequently.

Severe Use Definition

- Frequent immersion in mud, water or sand
- Racing or race-style high RPM use
- Prolonged low speed, heavy load operation
- Extended idle
- Short trip cold weather operation

Pay special attention to the oil level. A rise in oil level during cold weather can indicate contaminants collecting in the oil sump or crankcase. Change oil immediately if the oil level begins to rise. Monitor the oil level, and if it continues to rise, discontinue use and determine the cause or see your dealer.

Break-In Period

The break-in period consists of the first 20 hours of operation. Careful treatment of a new engine and drive components will result in more efficient performance and longer life for these components.

- Drive vehicle slowly at first while varying the throttle position. Do not operate at sustained idle.
- Pull only light loads.
- Perform regular checks on fluid levels and other areas outlined on the daily pre-ride inspection checklist.
- Change both the engine oil and filter after 20 hours or one month.
- See "Owner's Manual" for additional break-in information.

Maintenance Chart Key

The following symbols denote potential items to be aware of during maintenance:

■ = **CAUTION: Due to the nature of these adjustments, it is recommended this service be performed by an authorized Polaris dealer.**

▶ = **SEVERE USE ITEM: See information provided above.**

E = **Emission Control System Service (California).**

NOTE: Inspection may reveal the need for replacement parts. Always use genuine Polaris parts.



WARNING

Improperly performing the procedures marked ■ could result in component failure and lead to serious injury or death. Have an authorized Polaris dealer perform these services.

Maintenance Intervals

2

Item	Maintenance Interval (whichever comes first)			Remarks
	Hours	Calendar	Miles (KM)	
■ Steering	-	Pre-Ride	-	Inspect and make adjustments as needed. See Pre-Ride Checklist later in this chapter.
▶ Front Suspension	-	Pre-Ride	-	
▶ Rear Suspension	-	Pre-Ride	-	
Tires	-	Pre-Ride	-	
▶ Brake Fluid Level	-	Pre-Ride	-	
▶ Brake Lever Travel	-	Pre-Ride	-	
Brake System	-	Pre-Ride	-	
Wheels / Fasteners	-	Pre-Ride	-	
Frame Fasteners	-	Pre-Ride	-	
▶ Engine Oil Level	-	Pre-Ride	-	
▶ E Air Filter, Pre-filter	-	Daily	-	Inspect; clean often
Coolant	-	Daily	-	Check level daily, change coolant every two years
▶ ADC Fluid	-	Daily	-	Check level daily, add as needed
▶ Power Steering Unit (if equipped)	-	Daily	-	Inspect daily, clean often
Head Lights / Tail Lights	-	Daily	-	Check operation; apply dielectric grease if replacing
▶ E Air Filter (main element)	-	Weekly	-	Inspect; replace as needed
▶ ■ Brake Pad Wear	10 H	Monthly	100 (160)	Inspect periodically
Battery	20 H	Monthly	200 (320)	Check terminals; clean; test
▶ E Engine Oil Change (Break-in Period)	20 H	1 M	-	Perform a break-in oil change at one month or 20 hours, whichever comes first
▶ Front Gearcase Fluid	25 H	Monthly	250 (400)	Inspect level
▶ Rear Gearcase Fluid	25 H	Monthly	250 (400)	Inspect level
▶ Transmission Fluid	25 H	Monthly	250 (400)	Inspect level
<p>▶ Perform these procedures more often for vehicles subjected to severe use.</p> <p>E Emission Control System Service (California)</p> <p>■ Have an authorized Polaris dealer perform these services.</p>				

MAINTENANCE

Item	Maintenance Interval (whichever comes first)			Remarks
	Hours	Calendar	Miles (KM)	
▶ General Lubrication	50 H	3 M	500 (800)	Lubricate all fittings, pivots, cables, etc.
■ E Throttle Cable / ETC Switch	50 H	6 M	500 (800)	Inspect; adjust; lubricate; replace if necessary
E Throttle Body Intake Duct	50 H	6 M	500 (800)	Inspect ducts for proper sealing / air leaks
▶ Drive belt	50 H	6 M	500 (800)	Inspect; replace as needed
▶ Cooling System	50 H	6 M	500 (800)	Inspect coolant strength seasonally; pressure test system yearly
▶ Radiator	50 H	6 M	500 (800)	Inspect; clean external surfaces
▶ Cooling Hoses	50 H	6 M	500 (800)	Inspect for leaks
▶ Engine Oil Change	100 H	6 M	1000 (1600)	Perform a break-in oil change at 20 hours or after one month of operation; change more frequently during cold weather operation
▶ Oil Filter Change	100 H	6 M	1000 (1600)	Replace with oil change
▶ Front Gearcase Fluid	-	12 M	1000 (1600)	Change Fluid
▶ Rear Gearcase Fluid	-	12 M	1000 (1600)	Change Fluid
▶ Transmission Fluid	-	12 M	1000 (1600)	Change Fluid
■ E Fuel System	100 H	12 M	1000 (1600)	Check for leaks at tank cap, fuel lines, fuel pump; replace lines every two years
▶ Engine Mounts	100 H	12 M	1000 (1600)	Inspect
▶ Exhaust Pipe / Silencer	100 H	12 M	1000 (1600)	Inspect
■ E Spark Plug	100 H	12 M	1000 (1600)	Inspect; replace as needed
▶ Wiring	100 H	12 M	1000 (1600)	Inspect for wear, routing, security; apply dielectric grease to connectors subjected to water, mud, etc.
■ Clutches (Drive and Driven)	100 H	12 M	1000 (1600)	Inspect; clean; replace worn parts
■ Front Wheel Bearings	100 H	12 M	1000 (1600)	Inspect; replace as needed
■ Brake Fluid	200 H	24 M	2000 (3200)	Change every two years
■ ADC Fluid	200 H	24 M	2000 (3200)	Change every two years
▶ Spark Arrestor (if applicable)	300 H	36 M	3000 (4800)	Clean out; or remove clean out plug
■ E Valve Clearance	1000 H	-	10000 (16000)	Inspect; adjust
■ Toe Adjustment	-			Inspect periodically; adjust as needed
▶ Headlight Aim	-			Adjust as needed

▶ Perform these procedures more often for vehicles subjected to severe use.
E Emission Control System Service (California)
■ Have an authorized Polaris dealer perform these services.

Grease Lubrication Points

There are grease fittings on each upper and lower front and rear A-arms, each rear bearing carrier, and on the front propshaft yoke. Apply a maximum of 3 pumps of grease at each of these areas.

Item	Recommended Lube	Method	Frequency
Front Propshaft Yoke	Polaris Premium U-Joint Grease	Grease fittings (3 pumps maximum) every 500 miles (800 km).	Grease before long periods of storage, and after pressure washing or submerging the ATV.
Front & Rear A-Arms			
Rear Bearing Carrier			

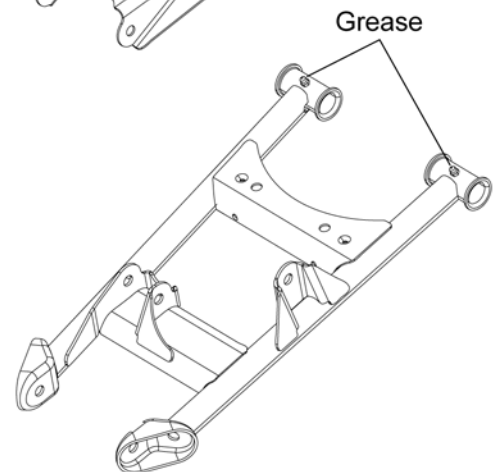
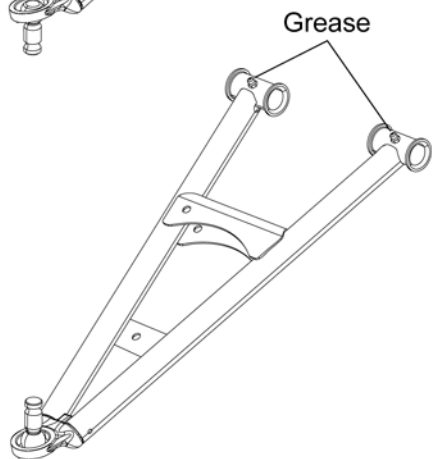
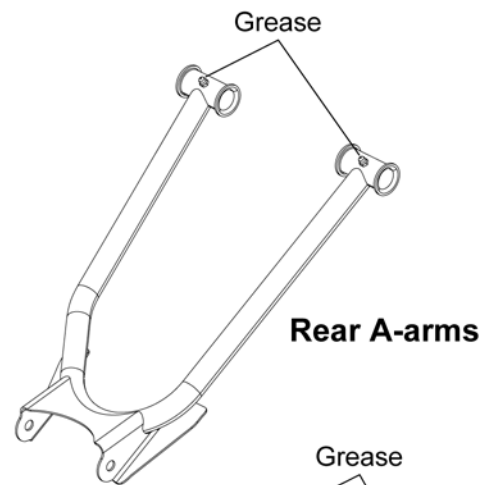
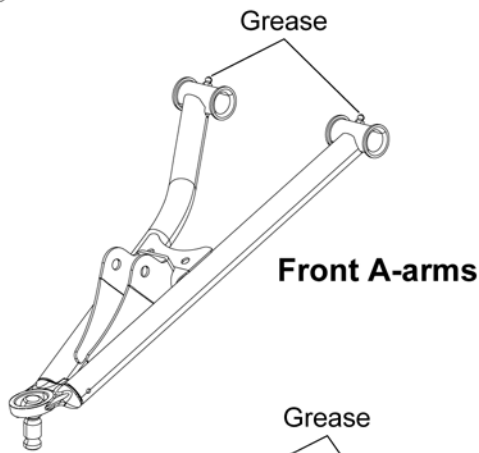
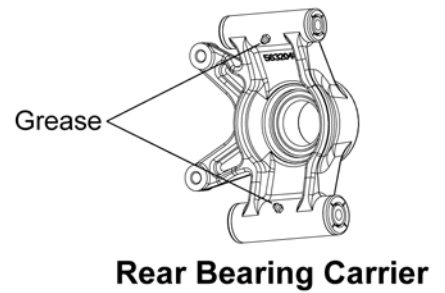
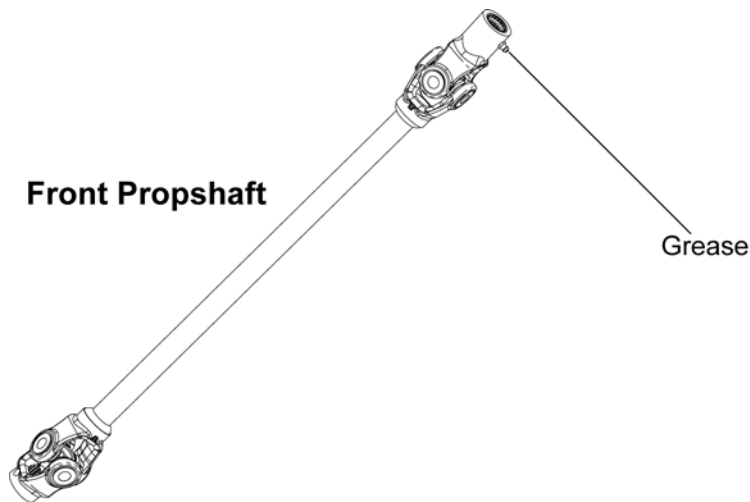

MAINTENANCE



Maintenance Quick Reference

III. #	Item	Lube Rec.	Method	Frequency*
1	Engine Oil	Polaris PS-4 PLUS 2W-50 Performance Synthetic	Add oil to proper level on dipstick	Change after 1st month or first 20 hours of operation, 100 hours thereafter; Change more often (25 hours) in severe duty conditions or short trip cold weather operation
2	Transmission	Synthetic Sportsman XP Transmission Fluid	Add fluid until it is visible at the fill hole threads	Check level every 25 hours; change fluid yearly
3	Engine Coolant	Polaris 60/40 Coolant	Maintain coolant level in coolant reservoir bottle.	Check level daily, change coolant every 2 years

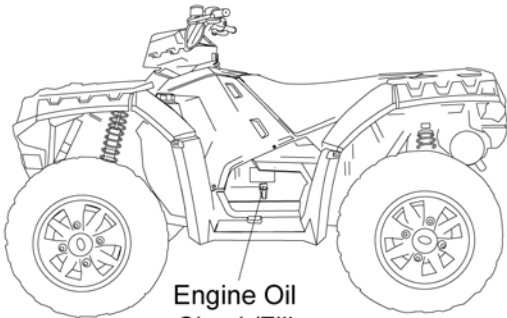
* More often under severe use, such as operated in water or under severe loads.



1. Engine Oil

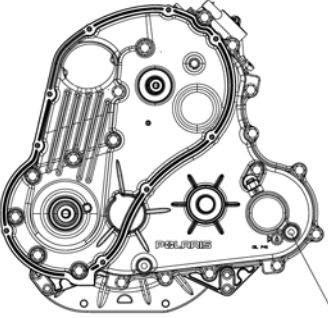

2. Transmission
(Rear RH wheel well)

Check/Fill Plug

3. Engine Coolant

SIDE VIEW
(Front RH wheel well)

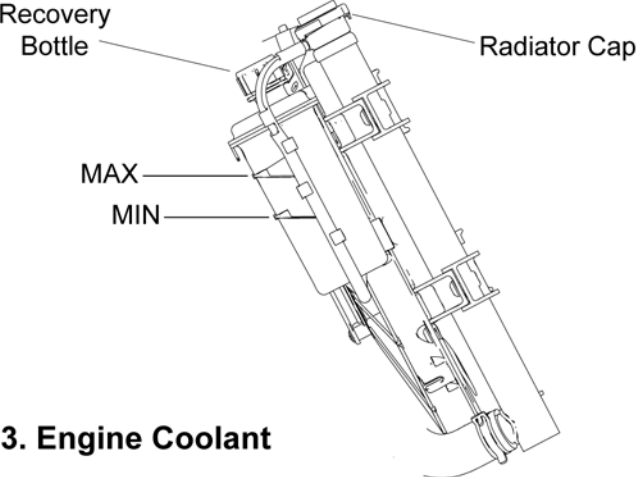

TOP VIEW
(Under front storage rack)

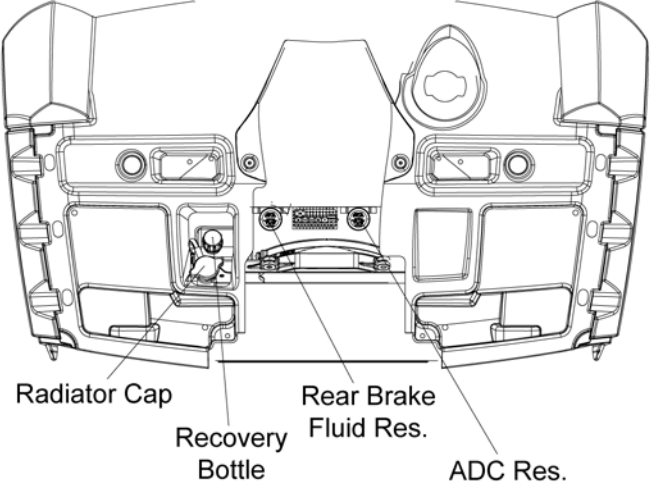

Maintenance Quick Reference, Continued.....

Ill. #	Item	Lube Rec.	Method	Frequency*
4	Front Gearcase ADC Reservoir	Polaris Premium ADC Front Drive Fluid	Maintain fluid level in ADC Reservoir to indicated level	Check level every 25 hours; change fluid every two years
5	Front Gearcase	Polaris Premium LT Demand Drive Fluid	Add fluid until it is visible at the fill hole threads	Check level every 25 hours; change fluid yearly or 1000 mi.
6	Rear Gearcase	Polaris ATV Angle Drive Fluid (ADF)	Add fluid until it is visible at the fill hole threads	Check level every 25 hours; change fluid yearly
7	Brake Fluid	Polaris DOT 4 Brake Fluid	Maintain fluid level in both master cylinder reservoirs to indicated levels	Check level during pre-ride inspection; change fluid every two years

* More often under severe use, such as operated in water or under severe loads.

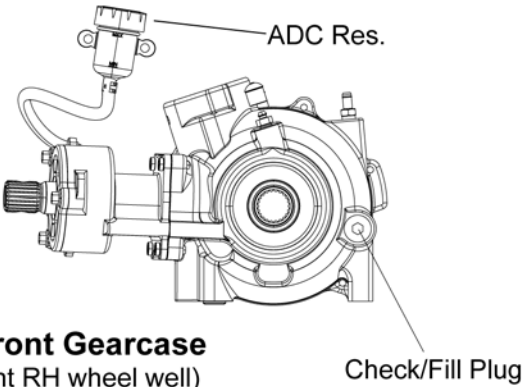
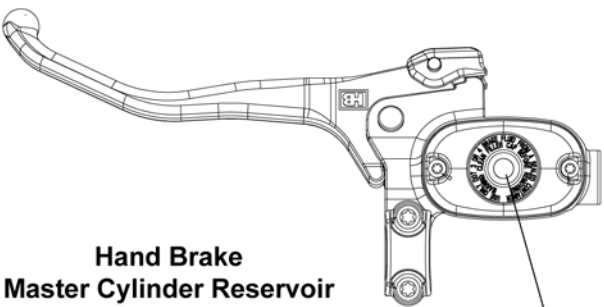
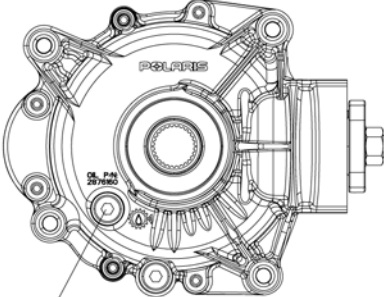
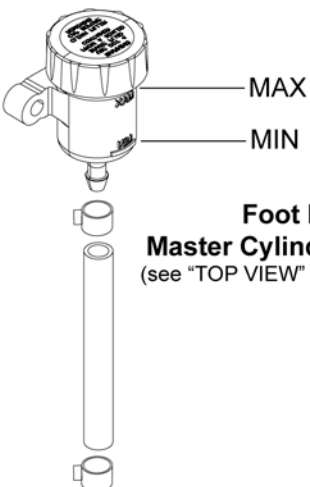
<p>4. ADC Reservoir (see "TOP VIEW" on previous page)</p>  <p>5. Front Gearcase (Front RH wheel well)</p> <p>Check/Fill Plug</p>	<p>7. Brake Fluid</p>  <p>Hand Brake Master Cylinder Reservoir</p> <p>Fluid Level Indicator</p>
<p>6. Rear Gearcase (Rear RH wheel well)</p>  <p>Check/Fill Plug</p>	 <p>Foot Brake Master Cylinder Reservoir (see "TOP VIEW" on previous page)</p> <p>MAX MIN</p>

MAINTENANCE**LUBRICANTS / SERVICE PRODUCTS****Polaris Lubricants, Maintenance and Service Products**

Part No.	Description
Engine / Transmission Lubricant	
2870791	Fogging Oil (12 oz. Aerosol)
2876244	PS-4 PLUS 2W-50 Performance Synthetic 4-Cycle Engine Oil (Quart)
2876245	PS-4 PLUS 2W-50 Performance Synthetic 4-Cycle Engine Oil (Gallon)
Gearcase Lubricants	
2877606	Synthetic Sportsman XP Transmission Fluid (Quart)
2876251	Premium LT Demand Drive Fluid (Quart) (12 count)
2872277	Premium Demand Drive Hub Fluid (2.5 Gallon) (2 count)
2876160	ATV Angle Drive Fluid (Quart) (12 count)
2872276	ATV Angle Drive Fluid (2.5 Gallon) (2 Count)
2870465	Pump for Gallon Jug
Coolant	
2871534	60/40 Coolant (Quart) (12 count)
2871323	60/40 Coolant (Gallon) (6 count)
Grease / Specialized Lubricants	
2871312	Grease Gun Kit
2871322	Premium All Season Grease (3 oz. cartridge) (24 Count)
2871423	Premium All Season Grease (14 oz. cartridge) (10 Count)
2871460	Starter Drive Grease (12 Count)
2871515	Premium U-Joint Lube (3 oz.) (24 Count)
2871551	Premium U-Joint Lube (14 oz.) (10 Count)
2871329	Dielectric Grease (Nyogel™)

NOTE: Each item can be purchased separately at your local Polaris dealer.

Additives / Sealants / Thread Locking Agents / Misc.	
2870585	Loctite™ Primer N, Aerosol, 25 g
2871956	Loctite™ Thread Sealant 565 (50 ml.) (6 Count)
2871949	Loctite™ Threadlock 242 (50 ml.) (10 Count)
2871950	Loctite™ Threadlock 242 (6 ml.) (12 Count)
2871951	Loctite™ Threadlock 262 (50 ml.) (10 Count)
2871952	Loctite™ Threadlock 262 (6 ml.) (12 Count)
2871953	Loctite™ Threadlock 271 (6 ml.) (12 Count)
2871954	Loctite™ Threadlock 271 (36 ml.) (6 Count)
2870584	Loctite™ 680-Retaining Compound (10 ml.)
2870587	Loctite™ 518 Gasket Eliminator / Flange Sealant (50 ml.) (10 Count)
2871326	Premium Carbon Clean (12 oz.) (12 Count)
2870652	Fuel Stabilizer (16 oz.) (12 Count)
2872189	DOT 4 Brake Fluid (12 Count)
2871557	Crankcase Sealant, 3-Bond 1215 (5oz.)
2872893	Engine Degreaser (12oz.) (12 Count)

NOTE: The number count indicated by each part number in the table above indicates the number of units that are shipped with each order.

GENERAL VEHICLE INSPECTION AND MAINTENANCE

Pre-ride / Daily Inspection

Perform the following pre-ride inspection daily, and when servicing the vehicle at each scheduled maintenance.

- Tires - check condition and tire pressure
- Fuel and oil - fill both to their proper level; do not overfill
- All brakes - check operation (includes auxiliary brake)
- Throttle - check for free operation
- Headlight / Taillight / Brakelight - check operation of all indicator lights and switches
- Engine stop switch (key switch) - check for proper function
- Wheels - check for loose wheel nuts
- Air cleaner element - check for dirt or water; clean or replace
- Steering - check for free operation, noting any unusual looseness in any area
- Loose parts - visually inspect vehicle for any damaged or loose nuts, bolts or other fasteners
- Engine coolant - check for proper level at the recovery bottle

Frame, Nuts, Bolts, Fasteners

Periodically inspect the torque of all fasteners in accordance with the maintenance schedule. Check that all cotter pins are in place. Refer to specific fastener torques listed in each chapter.

Controls

Check handlebar controls for proper operation, positioning and adjustment.

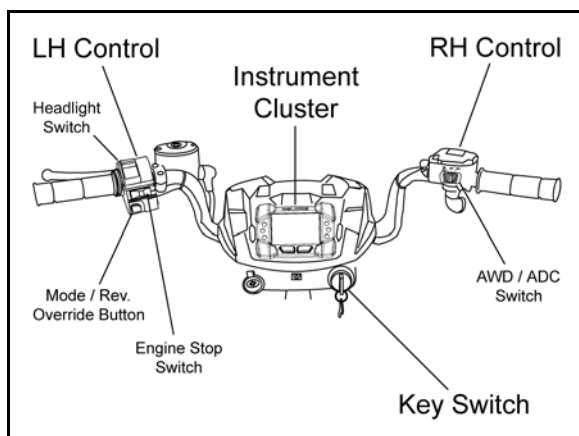

FUEL SYSTEM AND AIR INTAKE

Fuel System

WARNING

Gasoline is extremely flammable and explosive under certain conditions.

- Always stop the engine and refuel outdoors or in a well ventilated area.
- Do not smoke or allow open flames or sparks in or near the area where refueling is performed or where gasoline is stored.
- Do not overfill the tank. Do not fill the tank neck.
- If you get gasoline in your eyes or if you swallow gasoline, seek medical attention immediately.
- If you spill gasoline on your skin or clothing, immediately wash it off with soap and water and change clothing.
- Never start the engine or let it run in an enclosed area. Engine exhaust fumes are poisonous and can result loss of consciousness or death in a short time.
- Never drain the fuel when the engine is hot. Severe burns may result.

Fuel Lines

1. Check fuel lines for signs of wear, deterioration, damage, or leakage. Replace if necessary.
2. Be sure fuel lines are routed properly and secured with cable ties where applicable.

CAUTION

Make sure lines are not kinked or pinched

3. Replace all fuel lines every two years.

MAINTENANCE

Fuel Filters

There are two fuel filters located within the fuel pump assembly. The fuel pump is non-serviceable. If the internal fuel pump filters require service, the fuel pump and fuel tank must be replaced as an assembly.

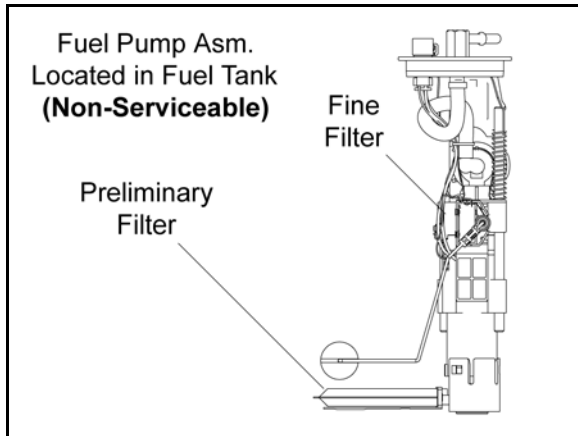

NOTE: See the “Electronic Parts Catalog” for more information. For all other information related to the EFI System, refer to Chapter 3.

Vent Line

1. Check the vent line from the fuel tank for signs of wear, deterioration, damage or leakage. Replace the line every two years.
2. Verify vent line is routed properly and secured with an appropriate number of cable ties.



Throttle Operation

Check for smooth throttle opening and closing in all handlebar positions. Throttle lever operation should be smooth and lever must return freely without binding.

1. Place the gear selector in neutral.
2. Set parking brake.
3. Start the engine and let it idle.
4. Turn handlebars from full right to full left. If idle speed increases at any point in the turning range, inspect throttle cable routing and condition. If cable is routed properly and in good condition, no adjustment is required.
5. Replace the throttle cable if worn, kinked, or damaged.

Electronic Throttle Control Switch (ETC) / Throttle Cable Adjustment

NOTE: Sportsman XP requires a new adjustment procedure.

1. Slide the boot back far enough to expose the inline cable adjuster sleeve and loosen the adjuster locknut.
2. Remove the (4) screws and cover from the RH control.
3. With handlebars centered and wheels pointing forward, slowly turn the adjuster sleeve counter-clockwise (out) just until the gap is removed between the throttle arm and the throttle arm stop (see illustration below).

NOTE: While moving the adjuster sleeve, “flip” the throttle lever slightly to remove slack in the cable.

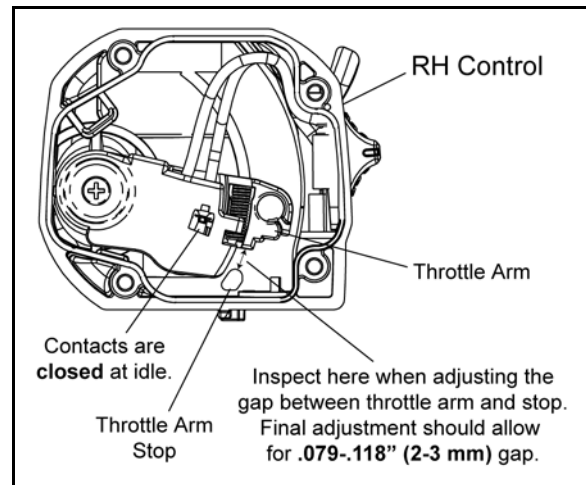

4. Turn the cable adjuster sleeve clockwise (in) 1.5 - 2 turns; tighten locknut and reinstall boot. After this adjustment there should be .079-.118” (2-3 mm) gap between throttle arm and throttle arm stop.

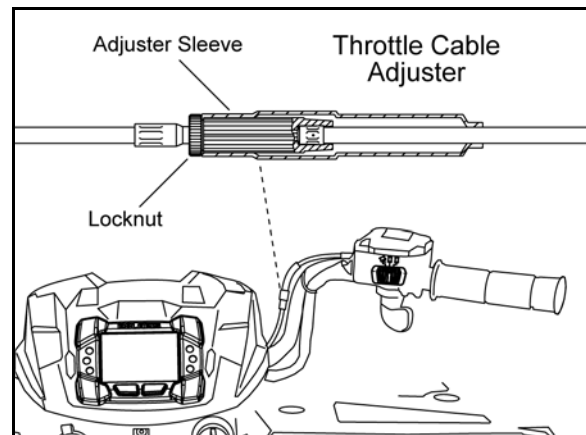

5. Reinstall the RH control cover and ensure the O-ring is properly in place. Securely tighten the (4) screws.
6. Place the vehicle in PARK and start the engine. Turn the handlebars from full left to full right while listening for any change in engine speed. If engine speed changes, loosen the locknut and turn the adjuster sleeve clockwise (in) an additional 1/2 turn and repeat this step.

Air Filter / Pre-Filter Service

It is advisable to replace the filter when it is dirty. However, in an emergency, it is permissible to clean the main filter if you observe the following practices.

- Never immerse the filter in water since dirt can be transferred to the clean air side of the filter.
- If compressed air is used never exceed a pressure of 40 PSI. Always use a dispersion type nozzle to prevent filter damage and clean from the inside to the outside.

It is recommended that the air filter and pre filter be replaced annually. When riding in extremely dusty conditions, replacement is required more often.

Removal:

1. Remove the seat to access the airbox cover.

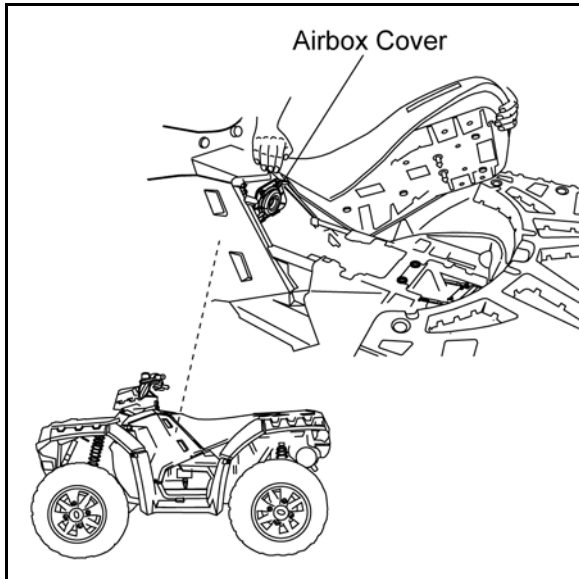

2. Unscrew the two knobs retaining the airbox cover and open the cover.

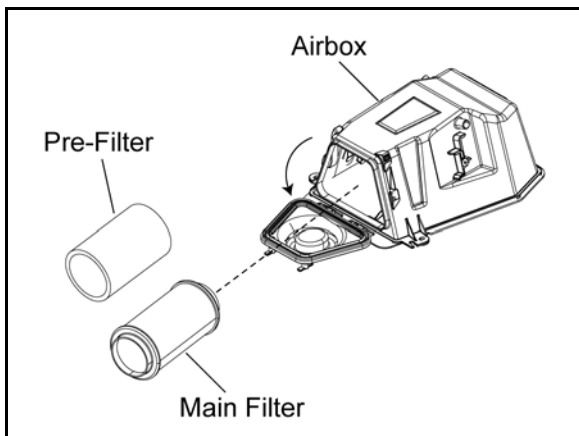

3. Remove the air filter assembly from the airbox.

Cleaning:

4. Slip the pre-filter screen off of main element. Clean the pre-filter with hot soapy water.
5. Rinse and dry thoroughly.
6. Inspect pre-filter screen for tears or damage.
7. Inspect main filter and replace if necessary. If the filter has been soaked with fuel or oil it must be replaced.

Installation:

8. Inspect airbox cover seal for damage. It should adhere tightly to the cover and seal all the way around. Replace seal as needed.
9. Reinstall pre-filter screen over main filter. Be sure the screen covers entire surface of main filter without folds, creases, or gaps.

NOTE: Apply a small amount of general purpose grease to the sealing edges of the filter before reinstalling.

10. Install air filter assembly into the airbox and position it correctly before closing the airbox cover.

NOTE: Proper placement of the air filter is important to prevent air leaks.

11. Close airbox cover and secure cover by tightening the retaining knobs.
12. Check the intake boot for cracks, deterioration, abrasion, or leaks. Replace as needed.

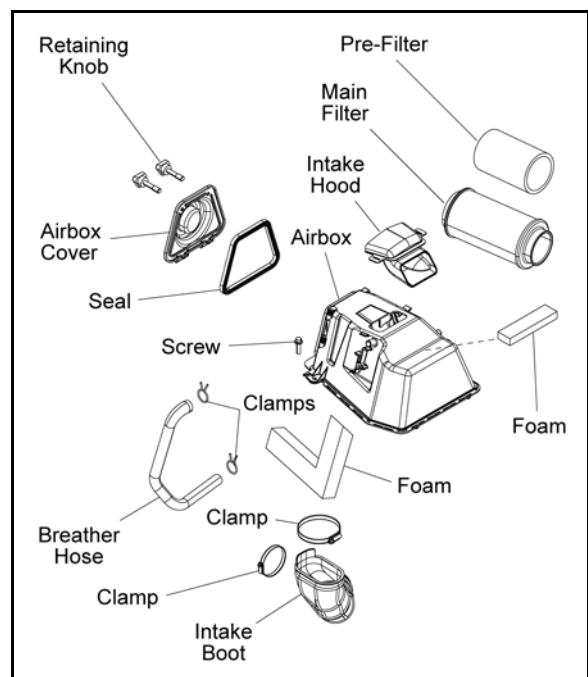

MAINTENANCE

ENGINE

Engine Oil Level

Polaris recommends the use of Polaris PS-4 PLUS synthetic engine oil. Always use PS-4 PLUS engine oil. Oil may need to be changed more frequently if Polaris engine oil is not used.

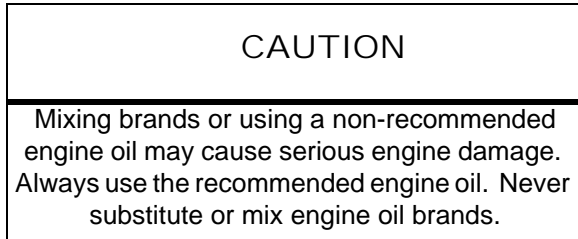

1. Locate the engine oil dipstick on the left side of the ATV.

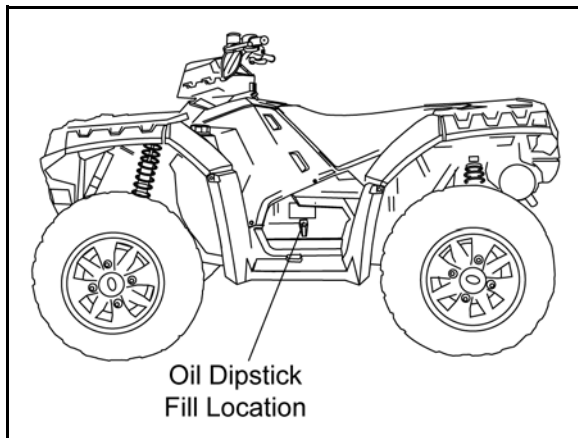

2. Position the ATV on a level surface.
3. Stop engine and remove the dipstick. Wipe it dry with a clean cloth.
4. Reinstall and tighten the dipstick.

NOTE: The dipstick must be screwed in completely to ensure an accurate measurement.

5. Remove the dipstick and check the oil level.

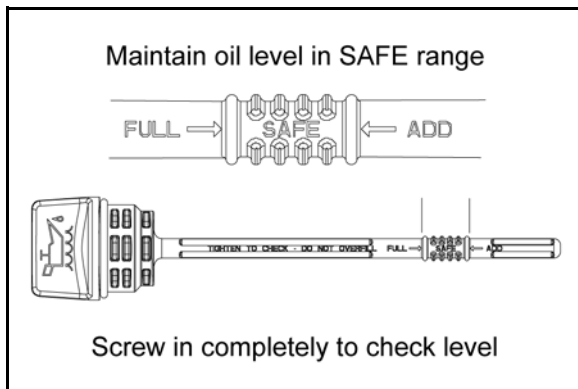

6. Maintain the oil level in the safe range. Do not overfill.

Engine Oil and Filter Change

Always change engine oil and filter at the intervals outlined in the Periodic Maintenance Chart. Always change the oil filter whenever changing the engine oil.

1. Position the ATV on a level surface.
2. Place the transmission in park.
3. Start engine and allow it to run for two to three minutes until the engine is warm.
4. Stop the engine.
5. Clean the area around the drain plug.

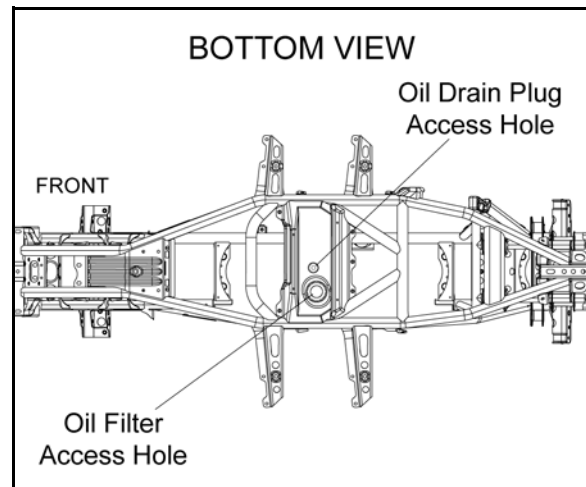

6. Place a drain pan beneath the engine crankcase.
7. Using a 6 mm Hex socket, remove the drain plug and allow the engine oil to drain completely.

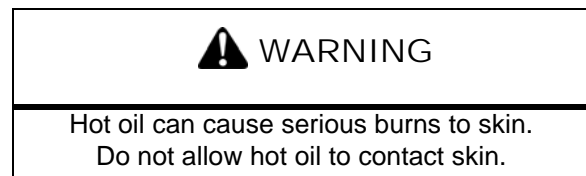
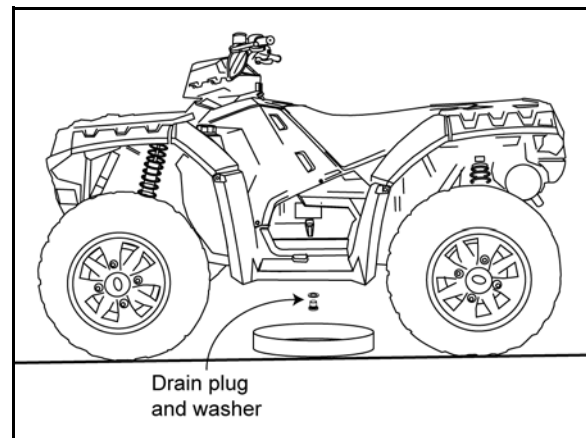

8. Replace the sealing washer on the drain plug.

NOTE: The sealing surfaces on the drain plug and crankcase should be clean and free of burrs, nicks or scratches.

- Reinstall drain plug and torque to **12 ft. lbs. (16 Nm)**.

 = T
Engine Drain Plug: 12 ft. lbs. (16 Nm)

- Locate oil filter through access hole in the skid plate. Place shop towels beneath the oil filter. Using oil filter wrench (PV-43527) turn oil filter counterclockwise to remove it.

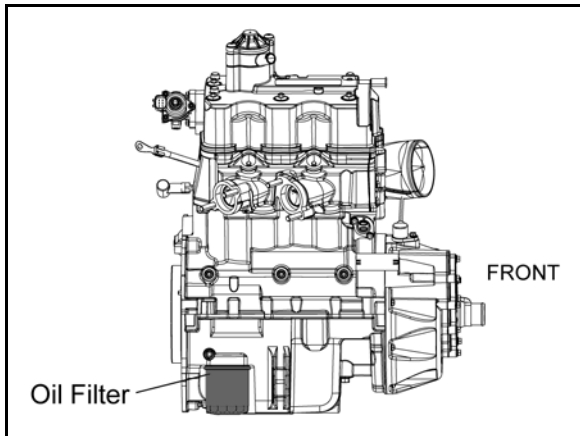

- Use a clean dry towel to clean the filter sealing surface on the crankcase.
- Check to make sure the O-ring on the new oil filter is in good condition. Lubricate O-ring on new filter with a film of fresh engine oil.
- Install new oil filter and turn by hand until filter gasket contacts the sealing surface, then turn it an additional 1/2 turn.

 = T
Oil Filter Torque: Turn by hand until filter gasket contacts sealing surface, then turn an additional 1/2 turn.

- Remove dipstick and fill engine with 1.75 qts. (1.66 L) of the recommended engine oil.



Recommended Engine Oil: PS-4 PLUS Synthetic 4-Cycle Engine Oil (PN 2876244) (Quart)

- Start the engine and allow it to idle for one to two minutes.

- Stop the engine and check for leaks.
- Re-check the oil level on the dipstick and add oil as necessary to bring the level to the upper mark on the dipstick.
- Dispose of used oil and filter properly.

Engine Breather Hose

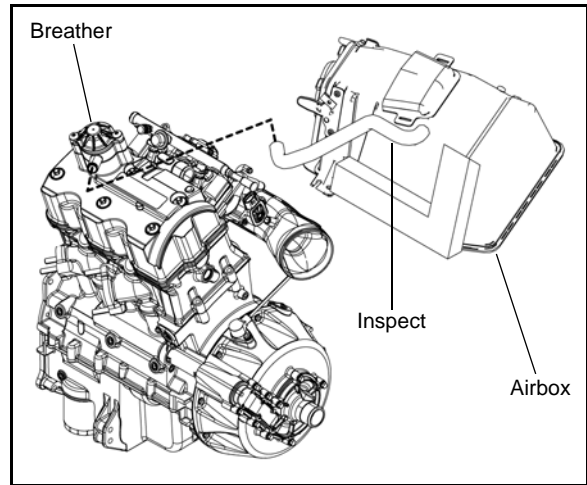
Be sure engine breather hose is routed properly and secured in place. **CAUTION:** Make sure line is not kinked or pinched.



Engine Breather Assembly

The engine breather assembly is located on top of the valve cover. Inspect and service the breather components as required.

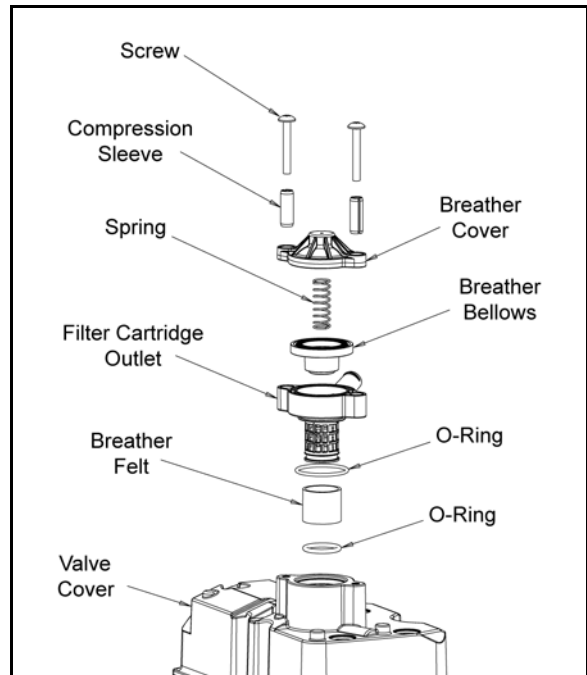

MAINTENANCE

Valve Clearance Adjustment

1. Remove the seat and both upper side panels.
2. Disconnect the shift linkage from the shift lever.
3. Remove the (2) screws retaining the lower portion of the air box.
4. Remove the hose from the breaker valve located on top of the valve cover.
5. Remove the push rivets retaining the right-hand portion of the rear cab to gain access to the bolts retaining the upper right-hand frame support.
6. Remove the (4) bolts retaining the frame support. Pull the support forward and down to remove it from the vehicle.
7. Remove the (2) Torx-head screws retaining the upper portion of the air box to the front cab.
8. Carefully disconnect the ECU by pulling the tab out while pulling down on the connector.
9. Loosen the hose clamp retaining the intake boot to the intake plenum and remove the boot.
10. Lift up on the air box and turn it sideways to gain access to the valve cover bolts.
11. Remove the spark plug wires and spark plugs.
12. Remove the (6) valve cover bolts and valve cover.



13. Remove PVT cover so the engine can be rotated (see "Drive Belt Removal" procedure within this chapter).

MAG & PTO ADJUSTMENT PROCEDURE

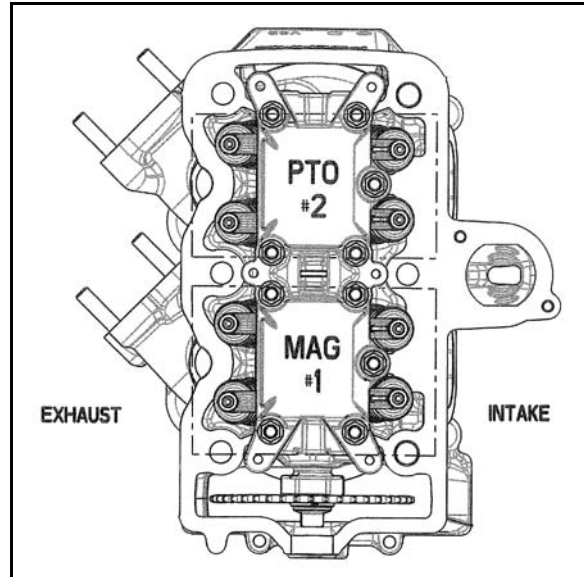

14. Turn the drive clutch counter-clockwise until the cam sprocket is in the **MAG (#1) Adjustment Position**.

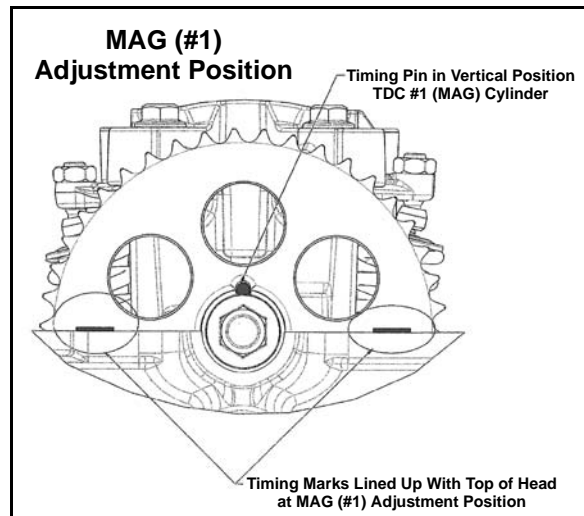

15. Set the MAG cylinder valve lash by placing the feeler gauge blade between the lash adjuster and valve as shown.

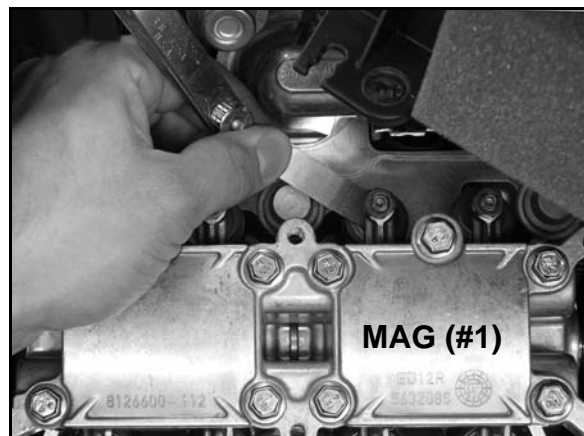

- Loosen the jam nut and turn the lash adjuster until the valve lash is correct.
- Set the intake and exhaust valve lash to specification.

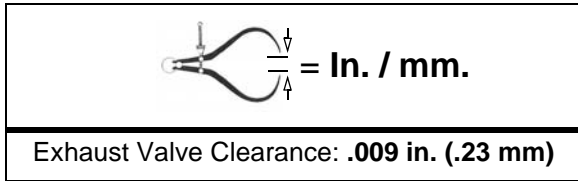
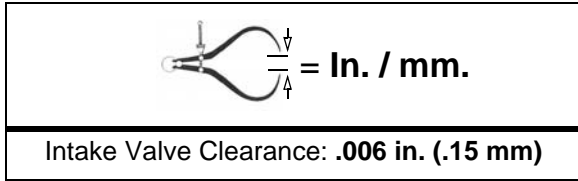

- Hold adjuster and torque the jam nut using a torque wrench w/10 mm crow's foot adaptor. Verify clearance is still correct after tightening the jam nut.

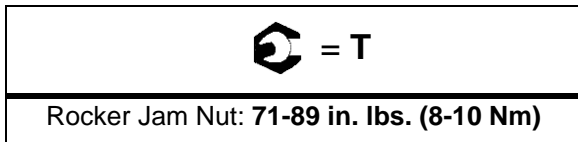

- Turn the drive clutch counter-clockwise to rotate the cam sprocket **225°** to the **PTO (#2) Adjustment Position**.

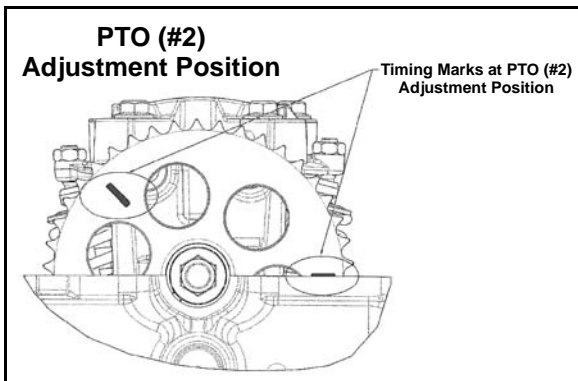

- Set the PTO cylinder valve lash by placing the feeler gauge blade between the lash adjuster and valve as shown.

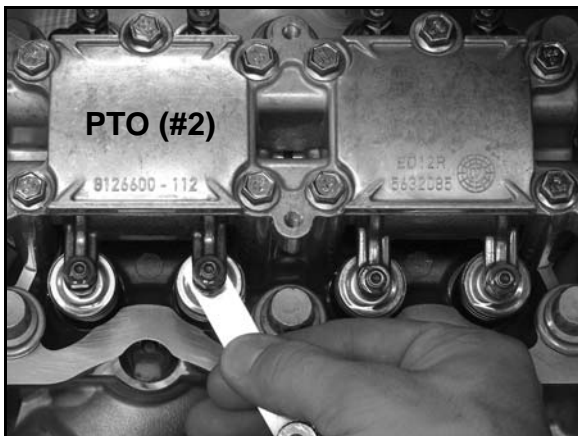

- Repeat steps 16-18.
- Clean sealing surfaces of the cylinder head and valve cover.
- Inspect the condition of the valve cover bolt rubber isolators. If rubber has become hardened or cracked, replace them.
- Install a new valve cover seal and install the valve cover. Torque the cover bolts to specification.

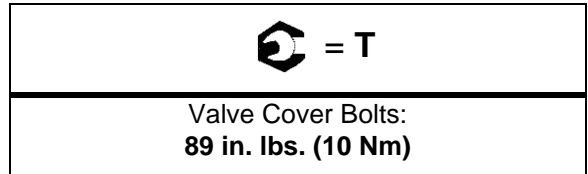

- Install the upper right-hand frame support and torque the (4) mounting bolts to specification.

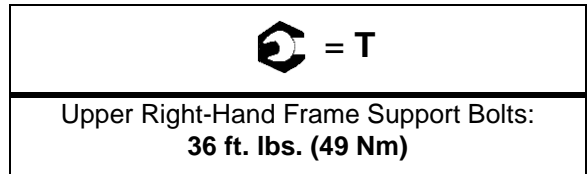

- Reassemble vehicle by reversing this procedure. Start the engine to ensure proper valve adjustment was performed.

Compression and Leakdown Tests

NOTE: This engine does NOT have decompression components. Compression readings will vary in proportion to cranking speed during the test.

Smooth idle generally indicates good compression. Low engine compression is rarely a factor in running condition problems above idle speed. Abnormally high compression can be caused by worn or damaged exhaust cam lobes.

A cylinder leak-down test is the best indication of engine condition. Follow tester manufacturer's instructions to perform a cylinder leak-down test. (Never use high pressure leakage testers as crankshaft seals may dislodge and leak).

Measured Cylinder Compression
210-250 psi (full throttle)

Cylinder Leakage Service Limit: 10%
(Inspect for cause if leakage exceeds 10%)

MAINTENANCE

Exhaust Silencer Cleaning

WARNING

Do not perform clean out immediately after the engine has been run, as the exhaust system becomes very hot. Serious burns could result from contact with exhaust components.

To reduce fire hazard, make sure that there are no combustible materials in the area when purging the exhaust silencer.

Wear eye protection.

Do not stand behind or in front of the vehicle while purging the carbon from the silencer.

Never run the engine in an enclosed area.

Exhaust contains poisonous carbon monoxide. Do not go under the machine while it is inclined.

Set the hand brake and block the wheels to prevent roll back.

Failure to heed these warnings could result in serious personal injury or death.

The exhaust silencer must be periodically purged of accumulated carbon as follows:

1. Remove the clean out plug on the bottom of the silencer.

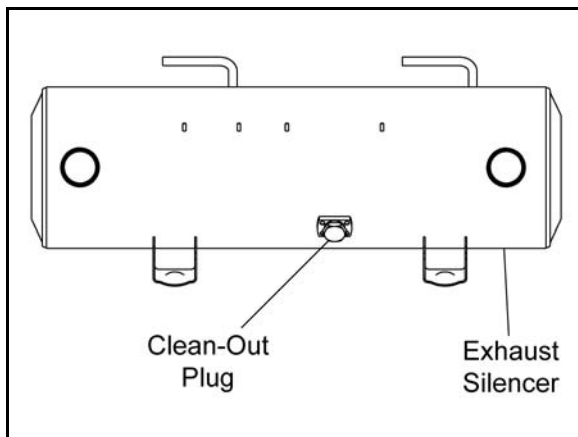

2. Place the transmission in park, and start the engine.
3. Purge accumulated carbon from the exhaust system by momentarily revving the engine several times.
4. If some carbon is expelled, cover the exhaust outlets and lightly tap on the silencer around the clean out plug with a rubber mallet while revving the engine several more times.

CAUTION

Wear protective gloves when covering the exhaust outlets. Serious burns could result from contact with exhaust components.

5. If particles are still suspected to be in the silencer, back the machine onto an incline so the rear of the machine is 1 ft. (30.5 cm) higher than the front. Place the transmission in park and block the wheels. Repeat steps 3 and 4 (see WARNING).

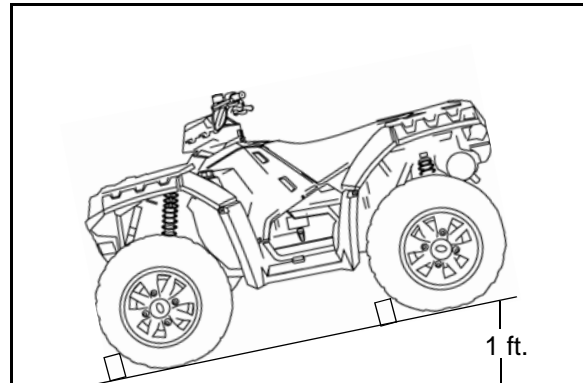

6. If particles are still suspected to be in the silencer, drive the machine onto the incline so the front of the machine is 1 ft. (30.5 cm) higher than the rear. Place the transmission in park and block the wheels. Repeat Steps 3 and 4 (see WARNING).
7. Stop the engine and allow the silencer to cool. Reinstall the clean out plug.

Engine Mount Fastener Torque

Check engine mounting fasteners and ensure they are tight. Also inspect the condition of the rubber mounts. If rubber mounts are cracked or show signs of fatigue, replace them.

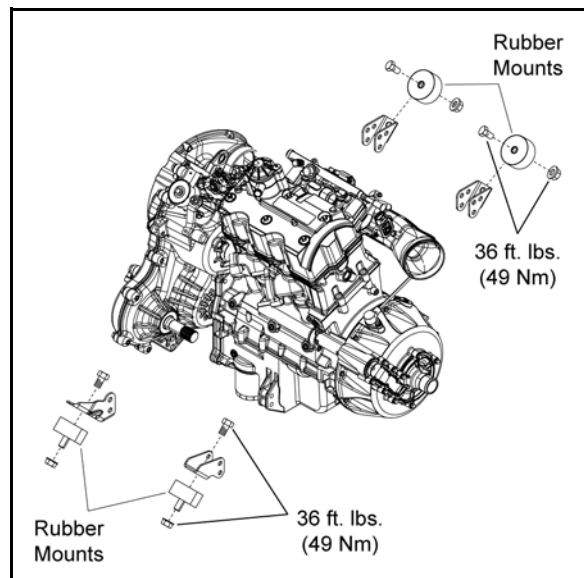

TRANSMISSION AND GEARCASES

Transmission Lubrication

NOTE: It is important to follow the transmission maintenance intervals described in the Periodic Maintenance Chart. Regular fluid level inspections should be performed as well.

The transmission fluid level should be checked and changed in accordance with the maintenance schedule.

- Be sure vehicle is positioned on a level surface when checking or changing the fluid.
- Check vent hose to be sure it is routed properly and unobstructed.

Transmission Fluid Level Check

The fill plug is located on the right-hand side of the transmission. Access the fill plug through the rear right-hand wheel well. Maintain the fluid level even with the bottom threads of the fill plug hole.

1. Position vehicle on a level surface.
2. Remove the fill plug and check the fluid level.

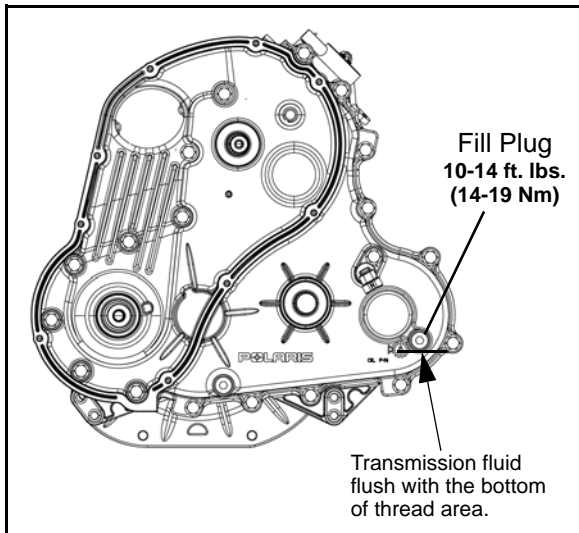

3. If fluid level is not even with the bottom threads, add the recommended fluid as needed. Do not overfill.
4. Reinstall the fill plug and torque to specification.

 = T
Drain/Plug Torque: 10-14 ft. lbs. (14-19 Nm)

Transmission Fluid Change

Access the drain plug through the rear right-hand wheel well. The plastic skid plate can be removed for better access to the drain plug.

1. Remove the fill plug (refer to “Transmission Fluid Level Check”).
2. Place a drain pan under the transmission drain plug.
3. Remove the drain plug and allow fluid to drain completely.

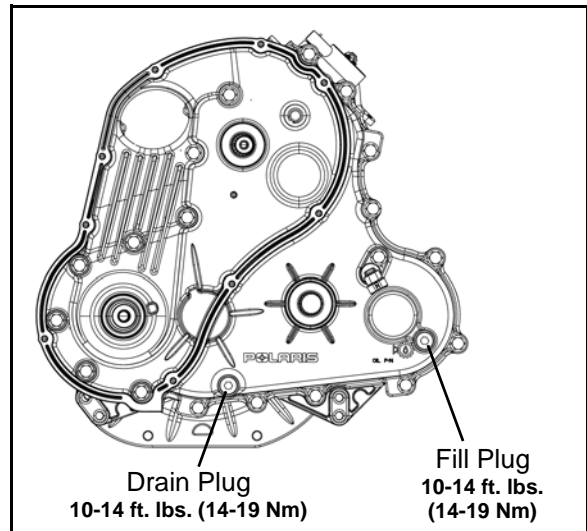

4. Clean the drain plug magnetic surface.
5. Reinstall drain plug with a new O-ring and torque to specification.
6. Add the recommended amount of fluid through the fill plug hole. Maintain the fluid level at the bottom of the fill plug hole when filling the transmission. Do not overfill.

Recommended Transmission Lubricant: Synthetic Sportsman XP Transmission Fluid (PN 2877606) (Quart)
Capacity: 32 oz. (946 ml)

7. Reinstall fill plug with a new O-ring and torque to specification.

 = T
Drain/Plug Torque: 10-14 ft. lbs. (14-19 Nm)

8. Check for leaks. Dispose of used fluid properly.

MAINTENANCE

Front Gearcase Lubrication

NOTE: It is important to follow the front gearcase maintenance intervals described in the Periodic Maintenance Chart. Regular fluid level inspections should be performed as well.

The front gearcase fluid level should be checked and changed in accordance with the maintenance schedule.

- Be sure vehicle is positioned on a level surface when checking or changing the fluid.
- Check vent hose to be sure it is routed properly and unobstructed.

Front Gearcase Fluid Level Check

The fill plug is located on the right side of the front gearcase. Access the fill plug through the front right-hand wheel well or through the front lower bumper. Maintain the fluid level even with the bottom threads of the fill plug hole.

1. Position vehicle on a level surface.
2. Remove the fill plug and check the fluid level.

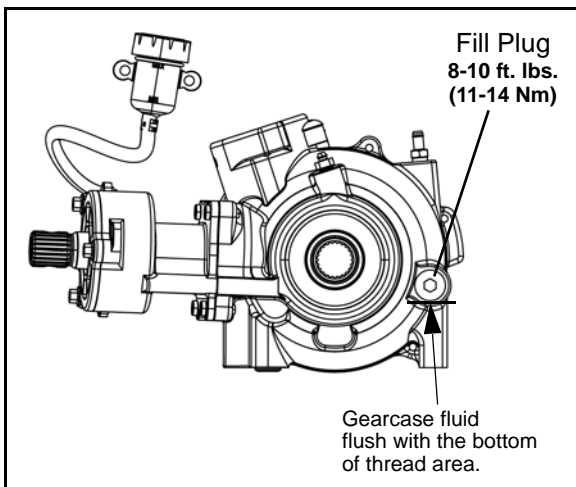

3. If fluid level is not even with the bottom threads, add the recommended fluid as needed. Do not overfill.
4. Reinstall the fill plug and torque to specification.

 = T
Drain / Fill Plug Torque: 8-10 ft. lbs. (11-14 Nm)



Front Gearcase Fluid Change:

The drain plug is located on the bottom side of the front gearcase. Access the drain plug through the access hole in the front skid plate.

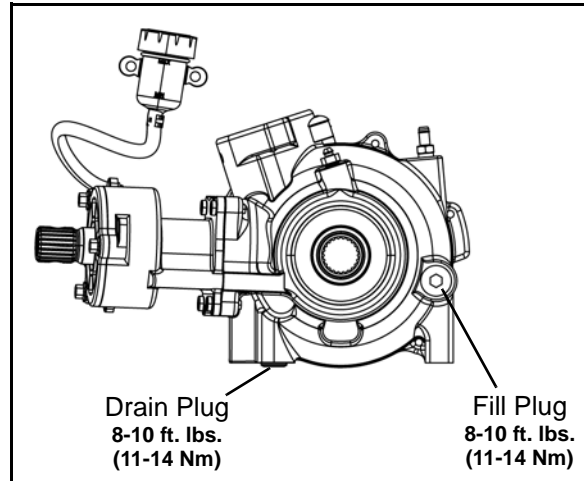
1. Remove the fill plug (refer to “Front Gearcase Fluid Level Check”).
2. Place a drain pan under the front gearcase drain plug.
3. Remove the drain plug and allow fluid to drain completely.



4. Clean the drain plug magnetic surface.
5. Reinstall drain plug with a new O-ring and torque to specification.
6. Add the recommended amount of fluid through the fill hole. Maintain the fluid level even with the bottom threads of the fill plug hole.

 = 
Recommended Front Gearcase Fluid: Premium LT Demand Drive Fluid (PN 2876251) (Quart) Capacity: 9.3 oz. (275 ml)

7. Reinstall fill plug with a new O-ring and torque to specification.

 = T
Drain / Fill Plug Torque: 8-10 ft. lbs. (11-14 Nm)

8. Check for leaks. Dispose of used fluid properly.

Front Gearcase ADC Fluid

NOTE: It is important to follow the front gearcase maintenance intervals described in the Periodic Maintenance Chart. Regular fluid level inspections should be performed as well.

The front gearcase ADC fluid level should be checked and changed in accordance with the maintenance schedule.

Front Gearcase ADC Fluid Level Check

The ADC fluid reservoir is located underneath the front rack as shown below. Maintain the fluid level between the “MIN” and “MAX” levels indicated on the reservoir.

1. Disengage the anchors and remove front rack assembly.
2. Check the fluid level of the ADC reservoir.

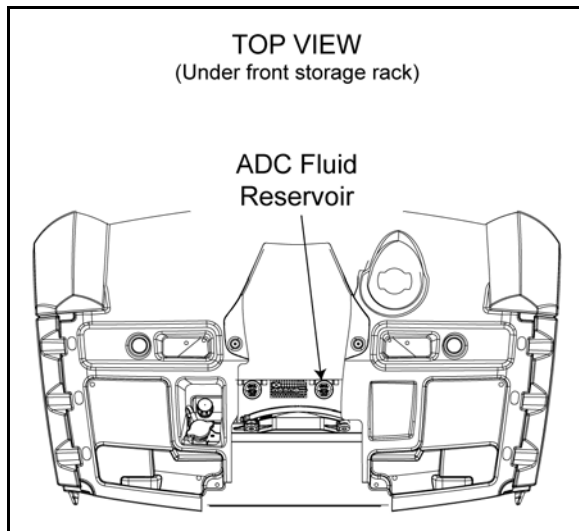

3. If fluid level is below the minimum mark on the reservoir, remove the cap and add the recommended fluid.
4. Reinstall the cap and front rack assembly.

Front Gearcase ADC Fluid Change:

1. Position the vehicle on a level surface and allow the vehicle to sit for at least 30 minutes.
2. Thoroughly clean the areas around the ADC reservoir and bleeder valves.
3. Remove the reservoir cap and diaphragm assembly.
4. Make sure the fluid inside the reservoir is free of debris. If any debris is found, use a clean shop towel or suction device to remove it from the reservoir.

NOTE: Debris in the reservoir may result in inadequate bleeding and reduced performance of the system.

5. Begin the bleeding process by filling reservoir to the “MAX” level with clean ADC Front Drive Fluid.

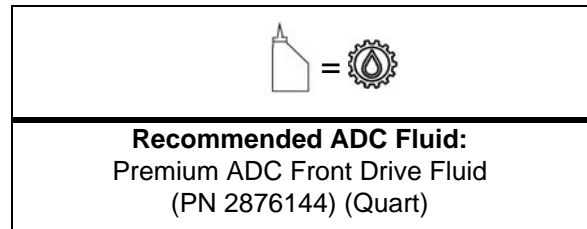

6. Locate bleeder valves found on each side of the front gearcase and remove the protective caps.

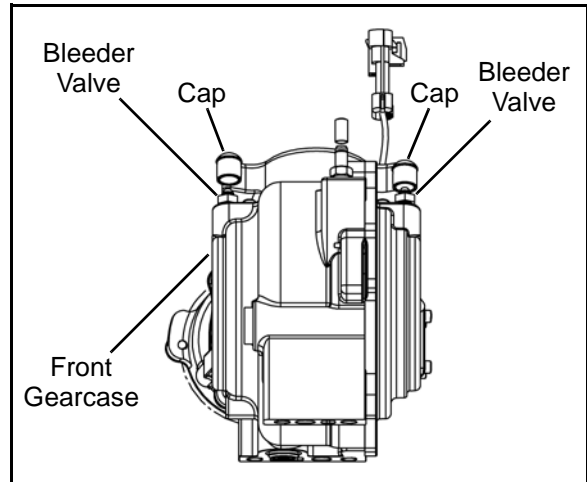

7. Attach a clean clear hose to one of the bleeder valves.
8. Slowly loosen the valve (counter-clockwise) and allow fluid and trapped air to flow from the fitting.

IMPORTANT: Do not allow ADC fluid in reservoir to drop below the “MIN” fill line. Close bleeder valve before the fluid level drops below the “MIN” fill line. Refilling an empty reservoir will result in air pockets becoming trapped.

9. Close the valve when clean (bubble-free) fluid begins to flow from the valve.
10. Repeat steps 7-9 on the remaining bleeder valve.
11. Torque the bleeder valves to specification and reinstall the protective caps.

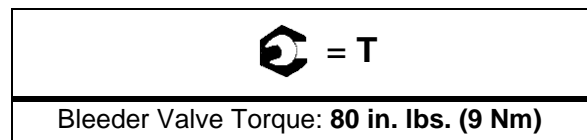

12. Fill reservoir to a level midway between “MAX” and “MIN” fill lines. Verify no debris is found in reservoir fluid.
13. Install the reservoir cap and diaphragm securely and wipe clean any fluid residue.

MAINTENANCE

Rear Gearcase Lubrication

NOTE: It is important to follow the rear gearcase maintenance intervals described in the Periodic Maintenance Chart. Regular fluid level inspections should be performed as well.

The rear gearcase fluid level should be checked and changed in accordance with the maintenance schedule.

- Be sure vehicle is positioned on a level surface when checking or changing the fluid.
- Check vent hose to be sure it is routed properly and unobstructed.

Rear Gearcase Fluid Level Check:

The fill plug is located on the right side of the rear gearcase. Maintain the fluid level even with the bottom threads of the fill plug hole.

1. Position the vehicle on a level surface.
2. Remove the fill plug and check the fluid level.

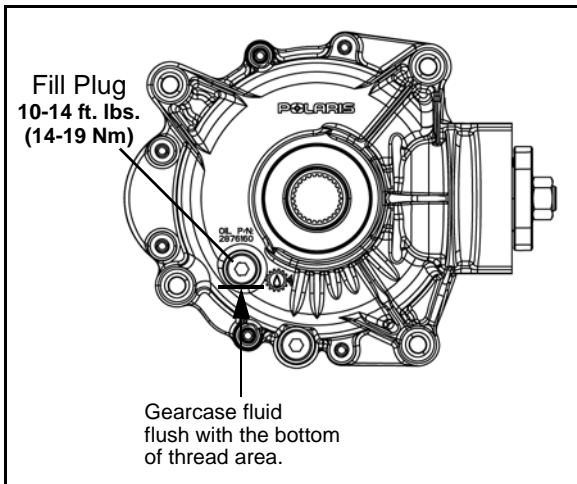

3. If fluid level is not even with the bottom threads, add the recommended fluid as needed. Do not overfill.
4. Reinstall fill plug and torque to specification.

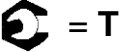
 = T
Drain / Fill Plug Torque: 10-14 ft. lbs. (14-19 Nm)

Rear Gearcase Fluid Change:

The drain plug is located on the bottom right-hand side of the rear gearcase. Access the drain plug from the rear right-hand side of the ATV.

1. Remove the fill plug (refer to “Rear Gearcase Fluid Level Check”).
2. Place a drain pan under the rear gearcase drain plug.
3. Remove the drain plug and allow the fluid to drain completely.

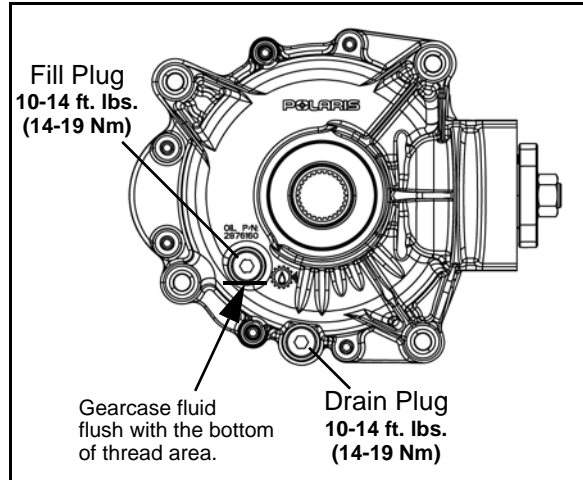

4. Clean the drain plug magnetic surface.
5. Reinstall drain plug with a new O-ring and torque to specification.
6. Add the recommended amount of fluid through the fill hole. Maintain the fluid level even with the bottom threads of the fill plug hole.

Recommended Rear Gearcase Lubricant: ATV Angle Drive Fluid (PN 2871653)
Capacity: 7.1 oz. (210 ml)

7. Reinstall fill plug with a new O-ring and torque to specification.

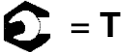
 = T
Drain / Fill Plug Torque: 10-14 ft. lbs. (14-19 Nm)

8. Check for leaks. Dispose of used fluid properly.

COOLING SYSTEM

Cooling System Overview

The engine coolant level is controlled, or maintained, by the recovery system. The recovery system components are the recovery bottle, radiator filler neck, radiator pressure cap and connecting hose.

As coolant operating temperature increases, the expanding (heated) excess coolant is forced out of the radiator past the pressure cap and into the recovery bottle. As engine coolant temperature decreases the contracting (cooled) coolant is drawn back up from the bottle, past the pressure cap, and into the radiator.

NOTE: Some coolant level drop on new vehicles is normal as the system is purging itself of trapped air. Observe coolant level often during the break-in period.

CAUTION

Overheating of engine could occur if air is not fully purged from system.

Polaris recommends the use of Polaris Premium 60/40 anti-freeze/coolant or a 50/50 mixture of high quality aluminum compatible anti-freeze/coolant and distilled water.

NOTE: Polaris Premium 60/40 is already premixed and ready to use. Do not dilute with water.

Coolant Level Inspection

The pressure cap and recovery bottle are located underneath the front rack as shown below. Maintain the coolant level between the “MIN” and “MAX” levels indicated on the recovery bottle.

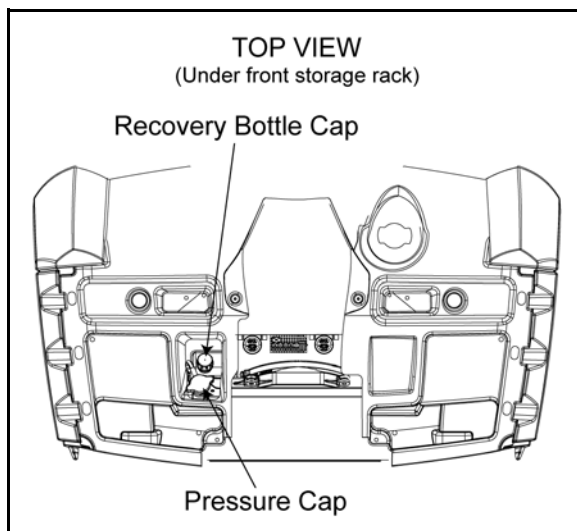

With the engine at operating temperature, the coolant level should be between the MAX and MIN marks on the coolant recovery bottle. If not, perform the following procedure.

1. Position the vehicle on a level surface.
2. View the coolant level in the recovery bottle. The coolant level can be viewed from inside the front right wheel well.

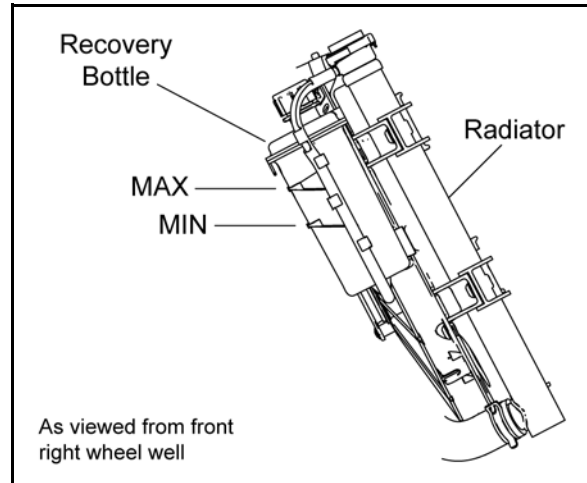

3. If the coolant level is below the “MIN” line on the bottle, remove the front rack assembly to access the radiator pressure cap and recovery bottle cap.

NOTE: If overheating is evident, allow system to cool completely and check coolant level in the radiator and inspect for signs of trapped air in system.

WARNING

Never remove the pressure cap when the engine is warm or hot. Escaping steam can cause severe burns. The engine must be cool before removing the pressure cap.

4. Remove the pressure cap. Using a funnel, add coolant to the top of the radiator filler neck.
5. Reinstall the pressure cap.

NOTE: Use of a non-standard pressure cap will not allow the recovery system to function properly.

6. Remove recovery bottle cap and add coolant using a funnel.
7. Fill recovery bottle to “MAX” level with Polaris Premium 60/40 Anti-Freeze/Coolant or a 50/50 mixture of anti-freeze/coolant and distilled water as required for freeze protection in your area.
8. Reinstall the recovery bottle cap.

MAINTENANCE

9. If coolant was required, start engine and check for leaks. Make sure radiator fins are clean to prevent overheating.
10. Add coolant as needed. Maintain the coolant level between the "MIN" and "MAX" marks on the bottle.
11. Reinstall the front rack assembly.

Cooling System Hoses

1. Inspect all hoses for cracks, deterioration, abrasion or leaks. Replace if necessary.

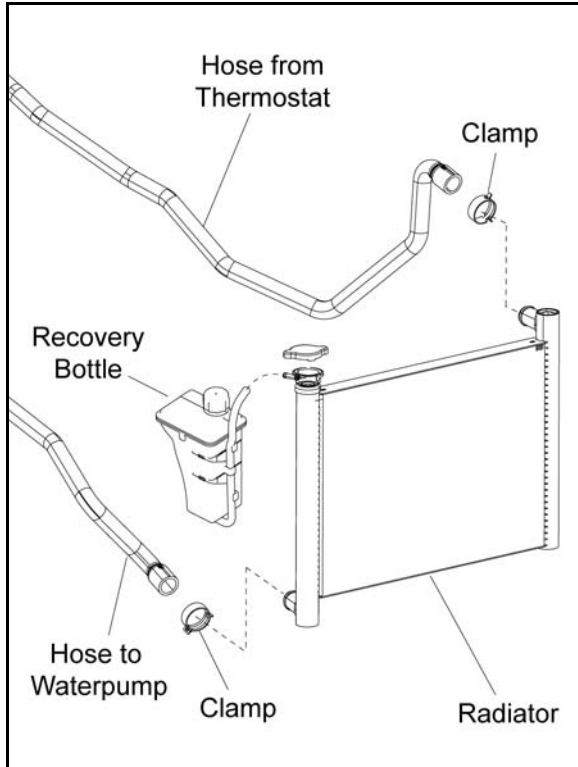

2. Check tightness of all hose clamps.

⚠ CAUTION

Do not over-tighten hose clamps at radiator, or radiator fitting may distort, causing a restriction to coolant flow. Radiator hose clamp torque is 36 in. lbs. (4 Nm).

Coolant Strength / Type

Test the strength of the coolant using an antifreeze hydrometer.

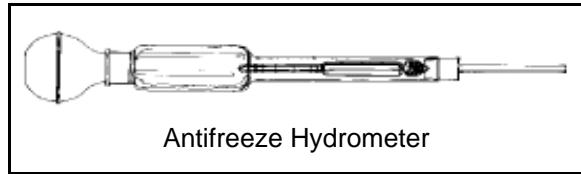

- A 50/50 or 60/40 mixture of antifreeze and distilled water will provide the optimum cooling, corrosion protection, and antifreeze protection.
- Do not use tap water, straight antifreeze, or straight water in the system. Tap water contains minerals and impurities which build up in the system.
- Straight water or antifreeze may cause the system to freeze, corrode, or overheat.



Recommended Anti-Freeze/Coolant:
Polaris 60/40 Anti-Freeze/Coolant
(PN 2871534) (Quart)

NOTE: For further information on the engine cooling system, refer to Chapter 4.

PVT / FINAL DRIVE / WHEEL AND TIRE

PVT Drying

NOTE: If operating the ATV through water, be sure to check the PVT system components for water ingestion. After operating in water, the ATV should be checked immediately.

1. Access the PVT drain plug on the bottom of the PVT cover using a long flat blade screwdriver between the frame and left-hand lower control arm from the rear of the ATV.
2. Remove the PVT drain plug and O-ring.

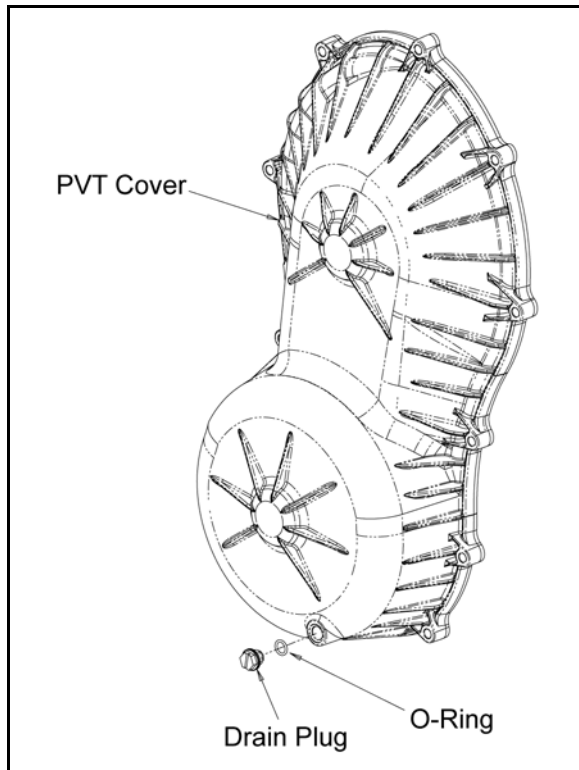

3. Allow the water to drain out completely.
4. Reinstall the drain plug and O-ring.
5. Start the engine and shift into park.
6. Apply varying throttle for 10-15 seconds to expel the moisture and air-dry the belt and clutches.

NOTE: Do not hold the throttle wide open for more than 10 seconds.

7. Allow the engine RPM to return to idle, then shift into low gear.
8. Test the PVT system for belt slippage. If the belt slips, repeat the process.

Drive Belt Removal

Refer to Chapter 7 "Clutching (PVT)" for more detail.

1. Elevate vehicle and remove the left rear wheel.
2. Remove the lower left-hand frame support.
3. Remove the (11) screws retaining the outer PVT cover. Pull the PVT cover out the LH wheel well.
4. Insert the belt removal tool **PN 2877408** into the driven clutch (tool included with vehicle's tool kit).

NOTE: Make sure the tool is square with the moveable sheave surface of the driven clutch.

5. Rotate the tool to open the driven clutch.
6. Walk the belt out of the driven clutch and drive clutch, and remove the belt from the vehicle.

Drive Shaft Boot Inspection

Inspect the front and rear drive shaft boots for damage, tears, wear, or leaking grease. If the rubber boots exhibit any of these symptoms, replace the boot(s). Refer to Chapter 8 for drive shaft boot replacement.

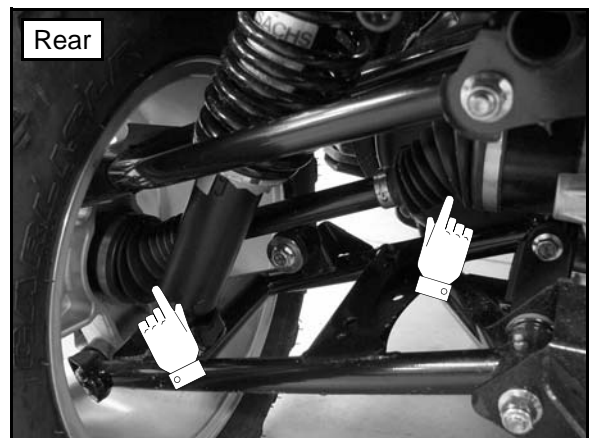

NOTE: Remove the CV boot shield from the front lower A-arms to inspect the front outer CV boots.

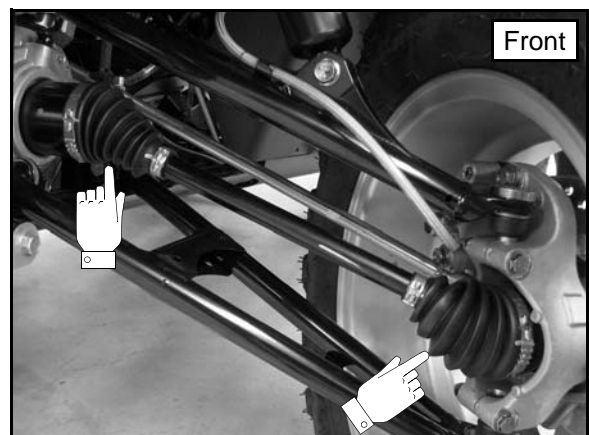

MAINTENANCE

Wheel and Hub Torque Table

Item	Nut Type	Specification
Aluminum Wheels	Tapered Nut (Long)	75 ft. lbs. (102 Nm)
Steel Wheels	Tapered Nut (Short)	45 ft. lbs. (61 Nm)
Hub Retaining Nuts (Front & Rear)	-	80 ft. lbs. (108 Nm)

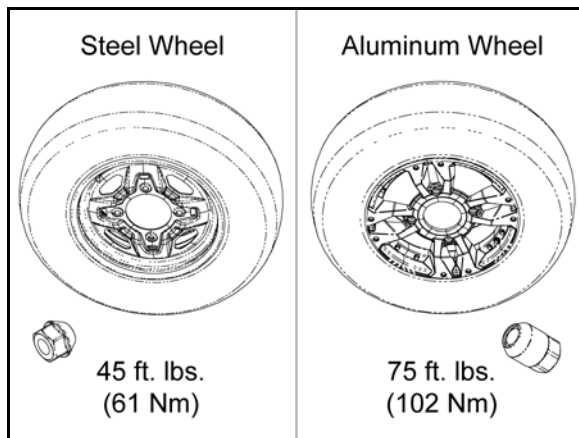

Wheel Removal

1. Position the vehicle on a level surface.
2. Stop the engine, place the transmission in PARK and lock the parking brake.
3. Loosen the wheel nuts slightly. If wheel hub removal is required, remove the cotter key and loosen the hub nut slightly.
4. Elevate the appropriate side of the vehicle by placing a suitable stand under the footrest frame.
5. Remove the wheel nuts and remove the wheel.
6. If hub removal is required, remove the hub nut and washers.

Wheel Installation

1. Verify the transmission is still in PARK and the parking brake is locked.
2. Install the wheel hub, washers, and hub nut, if previously removed.
3. Place the wheel in the correct position on the wheel hub. Be sure the valve stem is toward the outside and rotation arrows on the tire point toward forward rotation.
4. Install the wheel nuts and finger tighten them to align the center of the wheel holes with the center of the tapered nuts.

IMPORTANT: It is possible to torque the wheel nut on a steel rim without the nut being centered in the hole. Be sure to center the wheel nuts before applying torque to prevent wheel nuts from coming loose.

5. Carefully lower the vehicle to the ground.
6. Torque the wheel nuts and/or hub nut to the proper torque specification listed in the "Wheel and Hub Torque Table".

CAUTION

Improperly installed wheels could affect vehicle handling and tire wear. On vehicles with tapered rear wheel nuts, make sure tapered end of nut goes into taper on wheel. Be sure to properly torque and install all wheel nuts.

7. If the hub nut was removed, install a new cotter pin after the hub nut has been tightened.

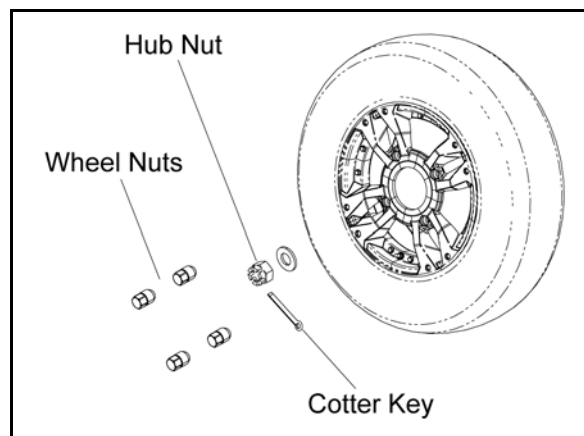

Tire Pressure

Tire Pressure Inspection (PSI - Cold)	
Front	Rear
7 psi (48 kPa)	5 psi (34.5 kPa)

Tire Inspection

⚠ WARNING

Operating an ATV with worn tires will increase the possibility of the vehicle skidding and possible loss of control.

Worn tires can cause an accident.

Always replace tires when the tread depth measures 1/8" (.3 cm) or less.

⚠ CAUTION

Maintain proper tire pressure. Refer to the warning tire pressure decal applied to the vehicle. Improper tire inflation may affect ATV maneuverability. When replacing a tire always use original equipment size and type. The use of non-standard size or type tires may affect ATV handling.

Tire Tread Depth

Always replace tires when tread depth is worn to 1/8" (3 mm) or less.

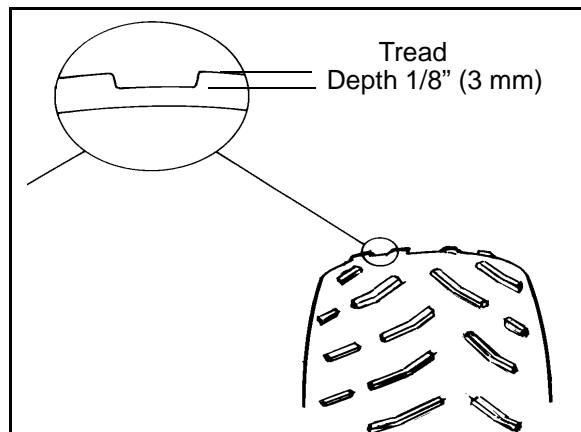

ELECTRICAL AND IGNITION SYSTEM

Battery Maintenance

Keep battery terminals and connections free of corrosion. If cleaning is necessary, remove the corrosion with a stiff wire brush. Wash with a solution of one tablespoon baking soda and one cup water. Rinse well with tap water and dry off with clean shop towels. Coat the terminals with dielectric grease or petroleum jelly.

⚠ WARNING

Battery electrolyte is poisonous. It contains sulfuric acid. Serious burns can result from contact with skin, eyes or clothing. Antidote:

External: Flush with water.

Internal: Drink large quantities of water or milk. Follow with milk of magnesia, beaten egg, or vegetable oil. Call physician immediately.

Eyes: Flush with water for 15 minutes and get prompt medical attention.

Batteries produce explosive gases. Keep sparks, flame, cigarettes, etc. away. Ventilate when charging or using in an enclosed space. Always shield eyes when working near batteries. **KEEP OUT OF REACH OF CHILDREN.**

NOTE: Absorbed Glass Mat (AGM) batteries are permanently sealed at the time of manufacture. AGM batteries are designed to minimize gassing and water loss, but can vent if overcharged.

IMPORTANT: Never attempt to open the battery. If the seal is broken, the battery will be ruined and will fail within a few weeks.

NOTE: If battery voltage is below 12.6V, fully charge the battery before putting into service. Charge for 3-5 hours at a voltage not to exceed 14.6V or 10 Amps. Voltage should reach at least 14.4V before end of charge.

MAINTENANCE

Battery Removal

1. Remove the seat to access the battery.

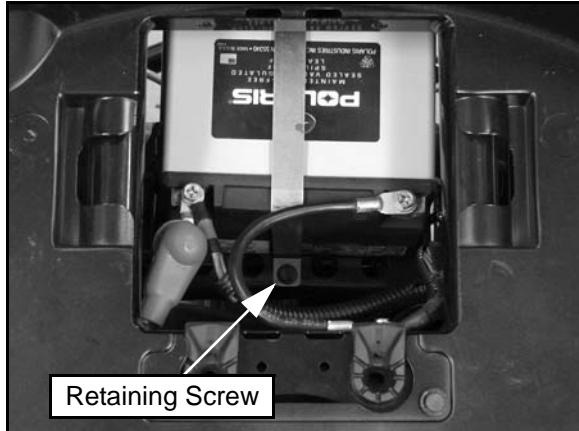

2. Disconnect battery negative (-) (black) cable first, followed by the positive (+) (red) cables.



CAUTION

To reduce the chance of sparks: Whenever removing the battery, disconnect the negative (black) cable first.

3. Remove the screw retaining the hold-down strap near the bottom front portion of the battery and remove the strap.
4. Lift the battery out of the ATV.

Battery Installation

IMPORTANT: Using a new battery that is not fully charged can damage the battery, resulting in a short battery life and can hinder performance. Follow the battery charging procedure before installation.

1. Ensure the battery is fully charged (see Chapter 12).
2. Place the battery into the ATV on its side with the positive (+) terminal towards the right side of the ATV.
3. Install the hold-down strap and the retaining screw.
4. Coat the battery terminals and bolt threads with Dielectric Grease (PN 2871329) or petroleum jelly.

5. Place the spacers on top of the battery terminals. Be sure they are placed between the battery terminal and cable(s).

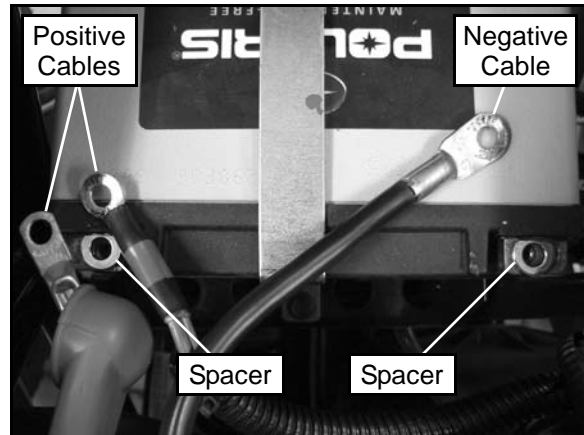

6. Connect and tighten the positive (+) (red) battery cable first, followed by the negative (-) (black) battery cable.



CAUTION

To reduce the chance of sparks: Whenever installing the battery, install the negative (black) cable last.

7. Verify cables are properly routed and fasteners are tight.

NOTE: The cables should be safely tucked away at the front of the battery.

8. Reinstall the seat.

Spark Plug Service

1. Remove the seat and upper right-hand side panel.
2. Disconnect the shift linkage from the shift lever.
3. Remove the spark plug caps. Clean plug area so no dirt and debris can fall into engine when plugs are removed.

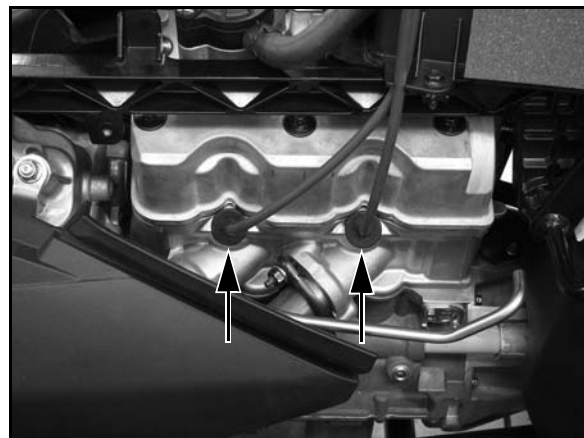

4. Using a 14 mm deep-well socket with an extension, remove the spark plug.

Spark Plug Inspection / Installation

1. Inspect electrodes for wear and carbon buildup. Look for a sharp outer edge with no rounding or erosion of the electrodes.
2. Clean with electrical contact cleaner or a glass bead spark plug cleaner only. **CAUTION:** A wire brush or coated abrasive should not be used.
3. Measure gap with a wire gauge. Refer to specifications in the following illustration for proper spark plug type and gap. Adjust gap if necessary by carefully bending the side electrode.

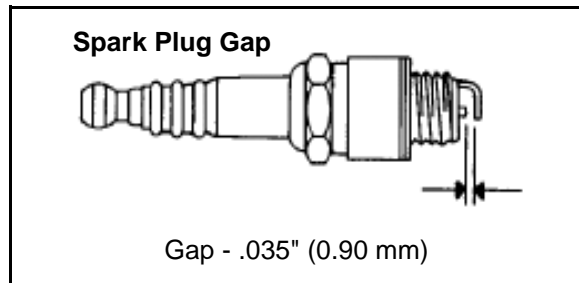

4. If necessary, replace spark plug with proper type. **CAUTION:** Severe engine damage may occur if the incorrect spark plug is used.

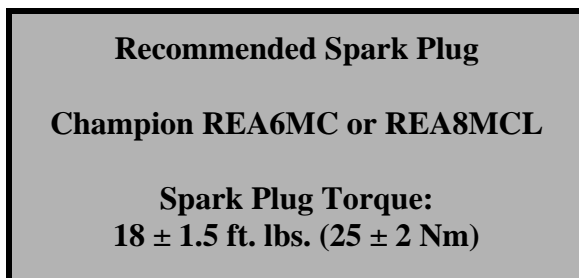

5. Apply a small amount of anti-seize compound to the spark plug threads.
6. Install spark plugs and torque to specification.
7. Make sure the high tension leads are retained by the airbox.



8. Reinstall the shift linkage, upper right-hand side panel, and seat.

Engine / Chassis Ground

Periodically inspect the electrical ground cable attachments. Cables and connections should be tight and corrosion-free.

Inspect the battery-to-chassis connection underneath the seat. This connection allows the chassis to provide a ground path.

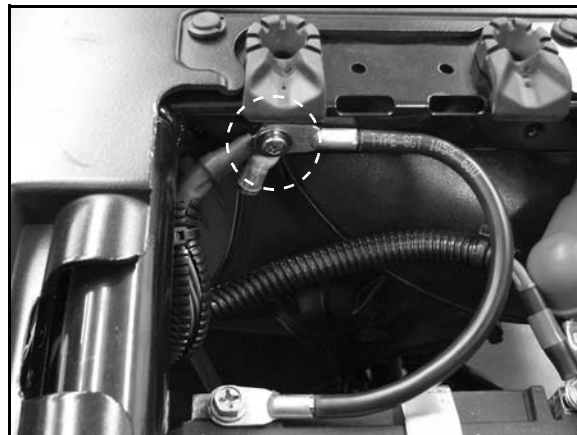

Inspect the chassis-to-engine connection on the left side of the engine attached to the engine/transmission housing. This connection allows the engine to provide a ground path.



MAINTENANCE

STEERING

Steering Inspection

The steering components should be checked periodically for loose fasteners, worn tie rod ends, and damage. Also check to make sure all cotter pins are in place. If cotter pins are removed, they must not be re-used. Always use new cotter pins.

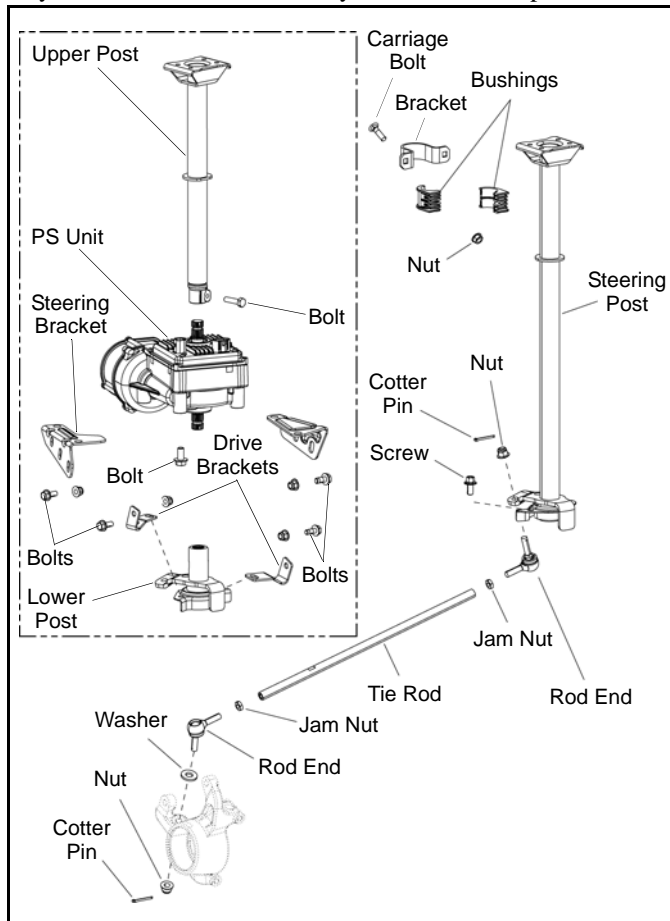

Replace any worn or damaged steering components. Steering should move freely through entire range of travel without binding. Check routing of all cables, hoses, and wiring to be sure the steering mechanism is not restricted or limited.

NOTE: Whenever steering components are replaced, check front end alignment. Use only genuine Polaris parts.

⚠ WARNING

Due to the critical nature of the procedures outlined in this chapter, Polaris recommends steering component repair and adjustment be performed by an authorized Polaris Dealer. Only a qualified technician should replace worn or damaged steering parts. Use only genuine Polaris replacement parts.

Power Steering Unit (EPS Models)

The power steering unit can be accessed through the front left wheel well by removing the mud guard.

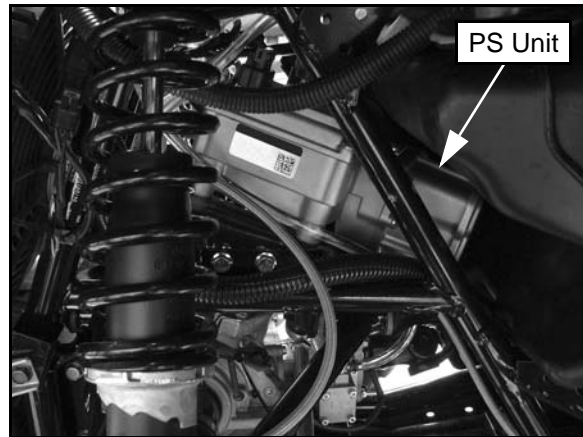

Frequently clean the areas around and on top of the power steering unit to allow for proper cooling.

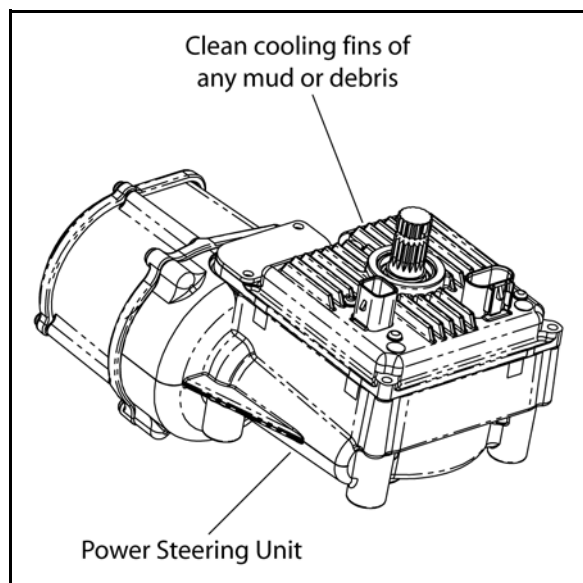

IMPORTANT: Be sure to clean these areas thoroughly after riding through muddy conditions.

Tie Rod End / Steering Inspection

To check for play in the tie rod end, grasp the steering tie rod, pull in all directions feeling for movement.

- Repeat inspection for inner tie rod end (on steering post).
- Replace any worn steering components. Steering should move freely through entire range of travel without binding.

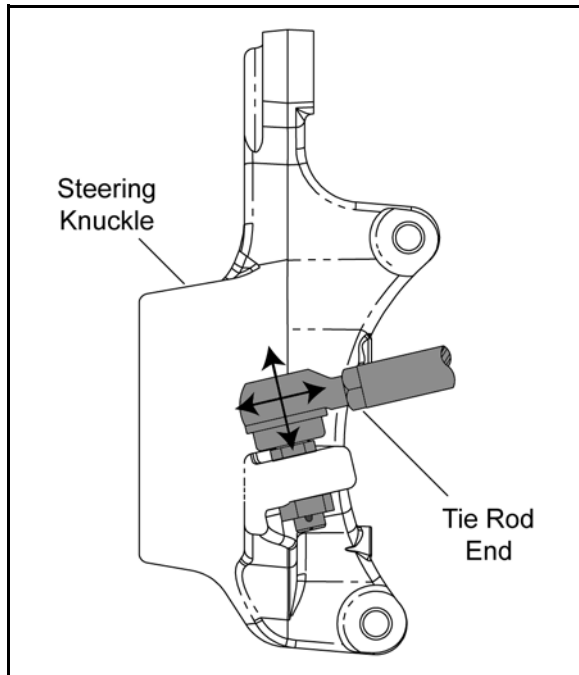

- Elevate front end of machine so front wheels are off the ground. Check for any looseness in front hub / wheel assembly by grasping the tire firmly at top and bottom first, and then at front and rear. Try to move the wheel and hub by pushing inward and pulling outward.
- If abnormal movement is detected, inspect the hub and wheel assembly to determine the cause.

Toe Alignment

Use the following procedure to check the toe alignment of the vehicle. The recommended toe alignment is 1/8" - 1/4" (3-6 mm) toe out.

1. Position the vehicle on a smooth level surface.
2. Set handlebars in a straight ahead position and secure handlebars in this position.

NOTE: The steering post frog can be used as an indicator of whether the handlebars are straight. The frog should always point straight back from the steering post.

3. Tie a length of string between two stands as shown in the following illustration. Position the stands so the string is flush or parallel with the side of the rear tire.

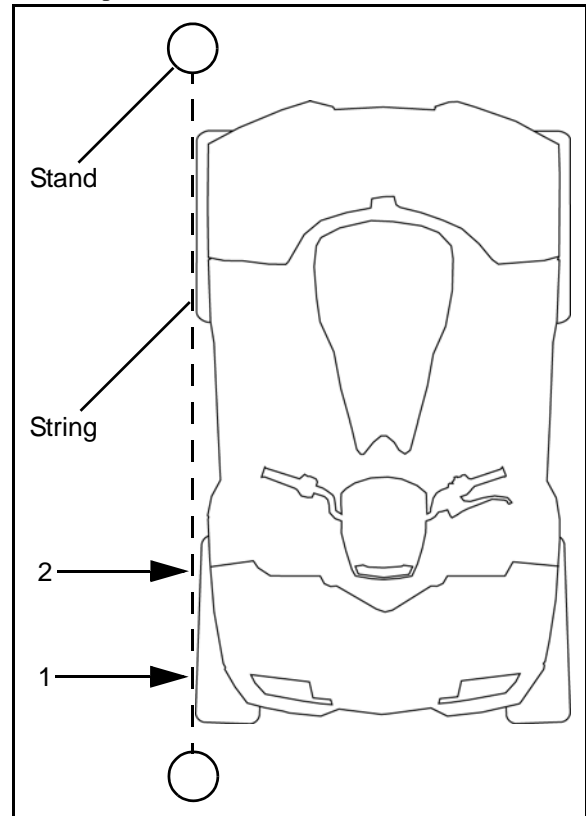

NOTE: If available, you may use a long straight-edge instead of a string.

4. Measure the distance from the string to the rim at the front (1) and rear (2) of the front rim. The rear measurement should be 1/16" - 1/8" (2-3 mm) more than the front measurement on each side of the vehicle to obtain the recommended 1/8" - 1/4" (3-6 mm) toe out alignment.
5. Repeat the measurement procedure on the other side of the vehicle.

NOTE: If you discover improper alignment, refer to "Toe Alignment Adjustment" procedure.

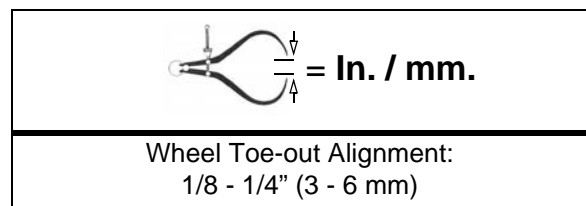

MAINTENANCE

Toe Alignment Adjustment

If toe alignment is incorrect, measure the distance between vehicle center and each wheel. This will tell you which tie rod needs adjusting.

NOTE: Be sure handlebars are straight ahead before determining which tie rod(s) need adjustment.

 **CAUTION**

During tie rod adjustment, it is very important that the following precautions be taken when tightening tie rod end jam nuts. If the rod end is positioned incorrectly it will not pivot, and may break

To adjust toe alignment:

- Hold tie rod end to keep it from rotating.
- Loosen jam nuts at both ends of the tie rod.
- Shorten or lengthen the tie rod until alignment is as required to achieve the proper toe out setting.
- Important: When tightening the tie rod end jam nuts, the rod ends must be held parallel to prevent rod end damage and premature wear. Damage may not be immediately apparent if done incorrectly. See illustration.

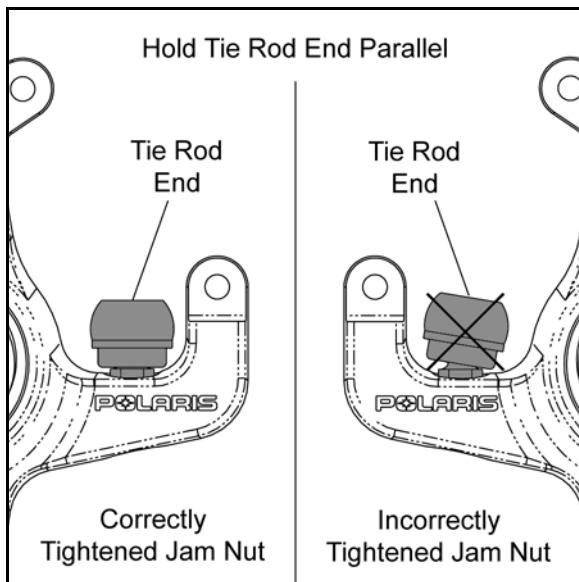

SUSPENSION

Suspension Inspection

Compress and release the suspension. Damping should be smooth throughout the range of travel.

- Check all suspension components and mounting fasteners for wear or damage.
- Inspect each shock body for leakage.

Suspension Spring Pre-Load Adjustment

The front and rear shock absorber springs are adjustable. Rotate the adjuster cam either direction to increase or decrease spring tension. Always adjust both sides equally.

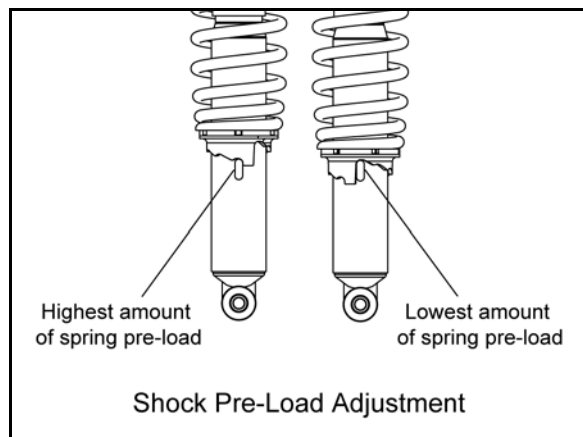

Operator weight and vehicle loading affect suspension spring pre-load requirements. Use Spanner Wrench (PN 2870872) to adjust pre-load as necessary to avoid bottoming of the shocks.

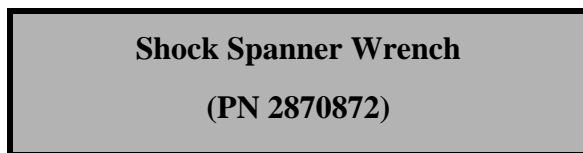

BRAKE SYSTEM

Brake Fluid Inspection

The following checks are recommended to keep the brake system in good operating condition. Service life of brake system components depends on operating conditions. Inspect brakes in accordance with the maintenance schedule and before each ride.

- Keep fluid level in the hand master cylinder reservoir to the indicated level inside reservoir.

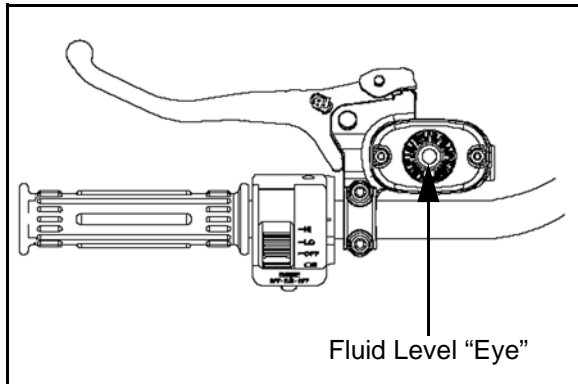

- Check the fluid level "eye". If it is clear, it is an indication that fluid is needed or the brake pads may be worn, which can reduce the fluid level.

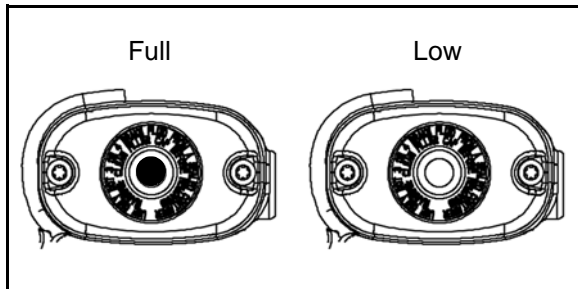

- If required, add brake fluid to .25" - .30" (6 - 8 mm) from the top of the reservoir.

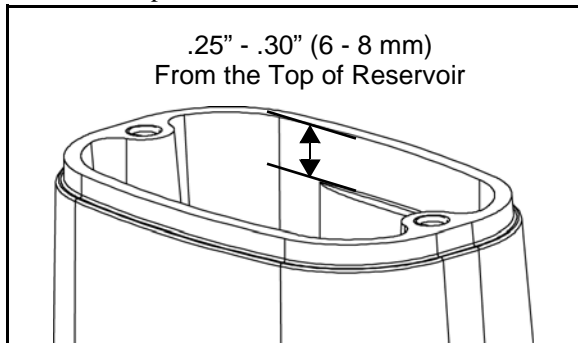

- Check the fluid level of the auxiliary brake master cylinder reservoir. Add fluid to the indicated level.

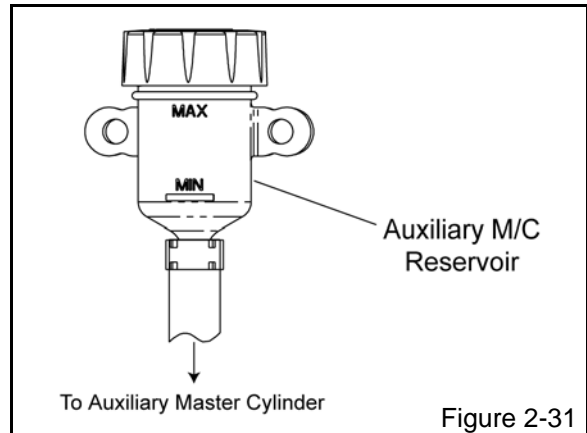

- Use Polaris DOT 4 Brake Fluid (PN 2872189).

⚠ CAUTION

DO NOT OVERFILL!
Excess brake fluid may cause brake drag.
Fill to the indicated fill line or specification.

- Check brake system for fluid leaks, excessive travel or spongy feel.
- Check brake pads for wear, damage or looseness.
- Check surface condition of the disc.
- Inspect thickness of brake pad friction material.

Brake Pad Inspection

Inspect brake pad friction material for excessive wear.

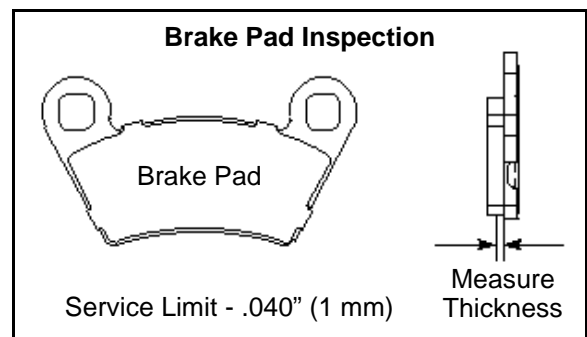

Hose / Fitting Inspection

Check brake system hoses and fittings for cracks, deterioration, abrasion, and leaks. Tighten any loose fittings and replace any worn or damaged parts.

MAINTENANCE

Auxiliary Brake Pedal

The hydraulic auxiliary brake system requires no adjustment. Frequently check the brake fluid level for the auxiliary brake system by viewing the level in the master cylinder reservoir located underneath the front rack assembly (see Figure 2-31).



- Check the effectiveness of the auxiliary brake by applying approximately 50 lbs. (23 kg) of downward force on the pedal.
- If brake pedal requires an excessive amount of travel to operate, inspect brake pads, pedal, linkage springs, rear master cylinder and hoses for wear, damage or leakage. Replace components as needed.

MAINTENANCE LOG

Service Date	Hours / Miles (km)	Service Performed / Comments	Dealer / Technician
	20 Hours / 1 Month (Break-In)		
	100 / 6 Months		

2

CHAPTER 3

ELECTRONIC FUEL INJECTION

SPECIAL TOOLS	3.2
FUEL TANK	3.4
FUEL LINE	3.5
EFI SERVICE NOTES	3.5
EFI SYSTEM LAYOUT	3.6
EFI COMPONENTS	3.7
ELECTRONIC FUEL INJECTION	3.9
ELECTRONIC CONTROL UNIT (ECU)	3.10
ECU SERVICE	3.10
ECU REMOVAL / REPLACEMENT	3.11
FUEL PUMP	3.11
FUEL SENDER / PUMP TEST	3.12
FUEL PUMP / FUEL TANK REMOVAL	3.13
FUEL PUMP / FUEL TANK INSTALLATION	3.14
FUEL PRESSURE REGULATOR	3.14
FUEL INJECTORS	3.14
FUEL INJECTOR SERVICE	3.14
FUEL INJECTOR TEST / REPLACEMENT	3.15
CRANKSHAFT POSITION SENSOR (CPS)	3.16
CPS TEST / REPLACEMENT	3.16
TEMP / MANIFOLD ABSOLUTE PRESSURE SENSOR (T-MAP)	3.17
T-MAP TEST / REPLACEMENT	3.17
IDLE AIR CONTROL VALVE (IAC)	3.17
IAC TEST	3.17
IAC REPLACEMENT	3.18
THROTTLE POSITION SENSOR (TPS)	3.19
TPS RESISTANCE TESTS / TPS TESTER KIT	3.19
CHECKING TPS READING	3.20
TPS ADJUSTMENT	3.21
TPS REPLACEMENT	3.22
ENGINE COOLANT TEMPERATURE SENSOR (ECT)	3.22
ECT SENSOR TEST	3.22
ECT SENSOR REPLACEMENT	3.23
IGNITION COIL	3.23
IGNITION COIL TESTS	3.23
IGNITION COIL AND HT LEAD REPLACEMENT	3.24
EFI DIAGNOSTICS	3.25
INSTRUMENT CLUSTER TROUBLE CODE DISPLAY	3.25
FUEL SYSTEM TROUBLESHOOTING	3.28
EFI SYSTEM BREAK-OUT DIAGRAMS	3.29
FUEL INJECTOR CIRCUITS	3.30
IDLE AIR CONTROL (IAC) CIRCUIT	3.31
CRANKSHAFT POSITION SENSOR (CPS) CIRCUIT	3.31
FUEL PUMP / FUEL LEVEL SENSOR CIRCUIT	3.32
FUEL PUMP CIRCUIT	3.33
FUEL GAUGE CIRCUIT	3.33
ENGINE COOLANT TEMPERATURE SENSOR (ECT) CIRCUIT	3.34
THROTTLE POSITION SENSOR (TPS) CIRCUIT	3.34
TEMP / MANIFOLD ABSOLUTE PRESSURE SENSOR (T-MAP) CIRCUIT	3.35
DIAGNOSTIC CONNECTOR CIRCUIT	3.35
DIAGNOSTIC CONNECTOR CIRCUIT (EPS MODELS)	3.36

ELECTRONIC FUEL INJECTION

SPECIAL TOOLS

Part Numbers / Descriptions

PART NUMBER	TOOL DESCRIPTION	
PU-43506-A	Fuel Pressure Gauge Kit	
PS-48762	Fuel Pressure Gauge Adaptor	
2201519	Throttle Position Sensor Tester Kit	
PU-47063	Digital Wrench™ Diagnostic Software (Includes most recent version of software and a serial number)	
PU-47471	Digital Wrench™ SmartLink Module Kit (PU-47470, PU-47469, PU-47468)	
	PU-47470	Digital Wrench™ PC Interface Cable
	PU-47469	Digital Wrench™ Vehicle Interface Cable
	PU-47468	Digital Wrench™ SmartLink Module

IMPORTANT: For the most recent information on Digital Wrench™ software and fileset downloads please visit the website: www.polaris.diagsys.com

⚠ WARNING

- * Gasoline is extremely flammable and explosive under certain conditions.
- * EFI components are under high pressure. Verify system pressure has been relieved before disassembly.
- * Never drain the fuel system when the engine is hot. Severe burns may result .
- * Do not overfill the tank. The tank is at full capacity when the fuel reaches the bottom of the filler neck. Leave room for expansion of fuel.
- * Never start the engine or let it run in an enclosed area. Gasoline powered engine exhaust fumes are poisonous and can cause loss of consciousness and death in a short time.
- * Do not smoke or allow open flames or sparks in or near the area where refueling is performed or where gasoline is stored.
- * If you get gasoline in your eyes or if you should swallow gasoline, seek medical attention immediately.
- * If you spill gasoline on your skin or clothing, immediately wash with soap and water and change clothing.
- * Always stop the engine and refuel outdoors or in a well ventilated area.

Fuel Pressure Gauge Kit - PU-43506-A

IMPORTANT: The EFI fuel system remains under high pressure, even when the engine is not running. Before attempting to service any part of the fuel system, the pressure must be relieved. The Fuel Pressure Gauge Kit has an integrated pressure relief valve that can be used to bleed off pressure.

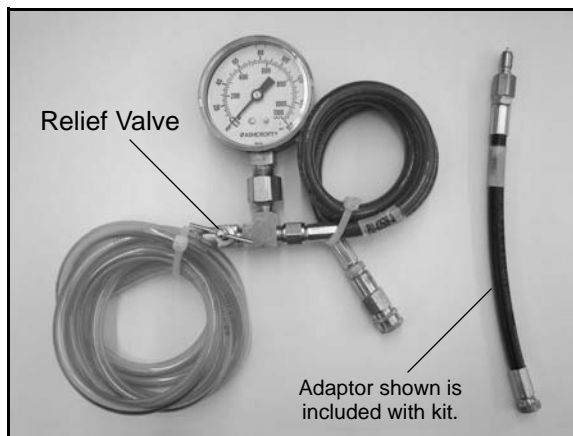

Fuel Pressure Gauge Adaptor - PS-48762

Used in conjunction with PU-43506-A to check fuel pressure.



Throttle Position Sensor Tester Kit - 2201519

This tester allows the use of a digital multi-meter to test TPS function and perform the “TPS Adjustment” procedure. Polaris Dealers can order special tools from SPX Corporation.

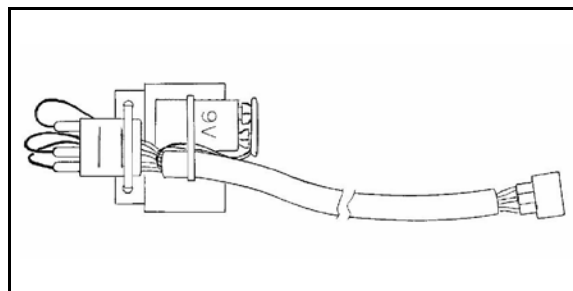

Digital Wrench™ Diagnostic Software PU-47063

This dealer-only software installs on laptop computers equipped with a CD drive and serial port connection, and is designed to replace multiple shop tools often used to test EFI components. It also includes step-by-step diagnostic procedures to aid technician repair and troubleshooting.

Digital Wrench™ SmartLink Module Kit - PU-47471

This module kit contains the necessary cables and hardware to communicate between the vehicle ECU and the Digital Wrench™ diagnostic software. Polaris dealers can also order the following separately: SmartLink Module PU-47468, Vehicle Interface Cable PU-47469 and PC Interface Cable PU-47470. This kit is available to Polaris dealers through our tool supplier, SPX (1-800-328-6657).

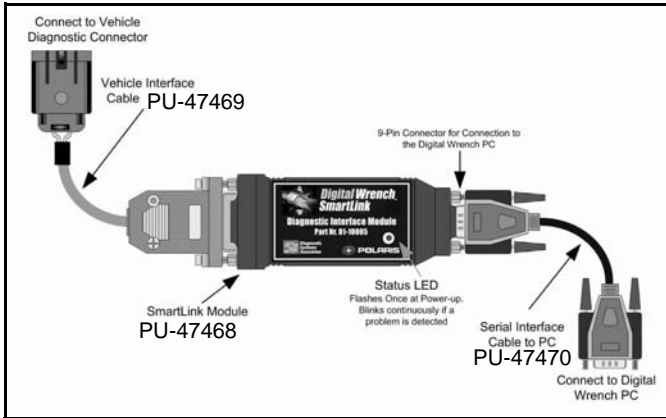

Digital Wrench™ - Diagnostic Connector

The diagnostic connector is located under the front rack, near the fuse box and rear brake reservoir.

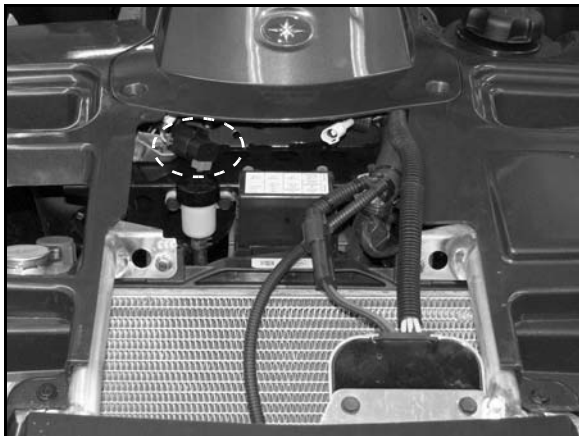

Digital Wrench™ - Download Website

Located at: www.polaris.diagsys.com

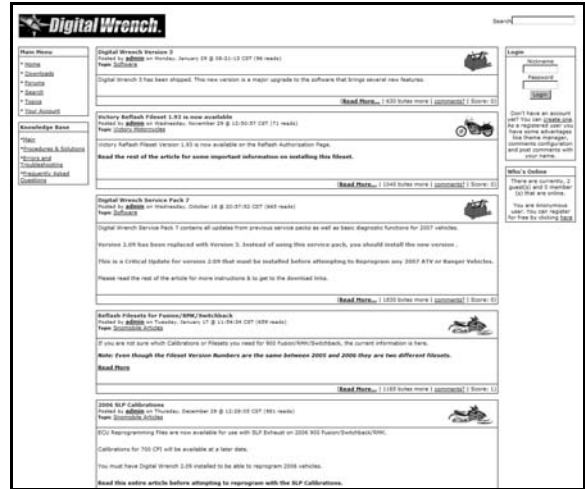

ELECTRONIC FUEL INJECTION

FUEL TANK

Exploded View

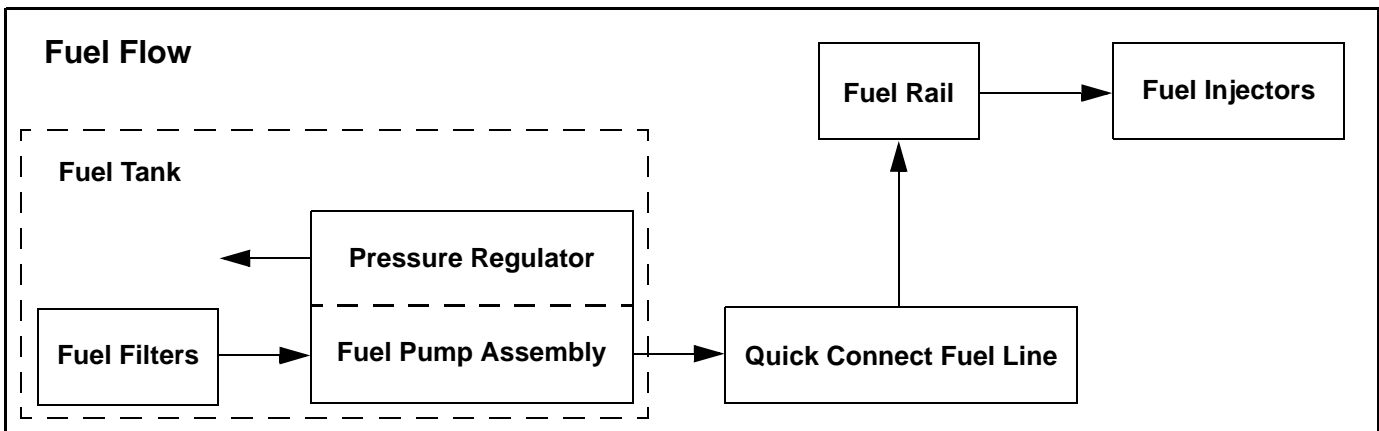
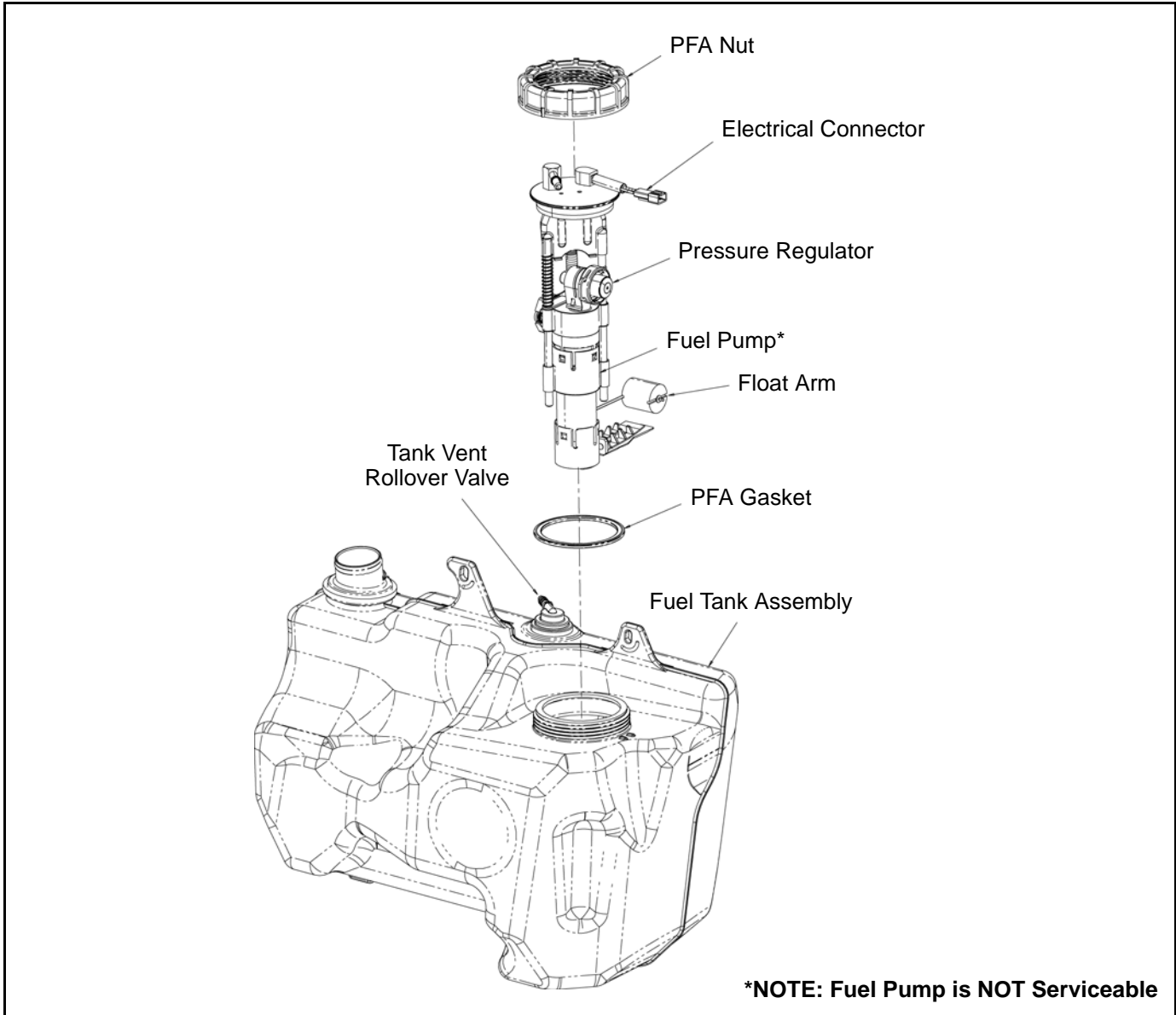

FUEL LINE**Quick Connect Removal / Installation****CAUTION**

Verify fuel system has been depressurized before performing this procedure.

All EFI models use quick connect fuel lines. Refer to the following steps for fuel line removal / installation:

1. Thoroughly clean the connector and place a shop towel around the fuel line to catch any dripping fuel.
2. Squeeze the connector tabs together and lift up on the white retainer. **NOTE: Use an O-ring pick or similar tool to disengage the inner white tab if the fuel tank is installed.**

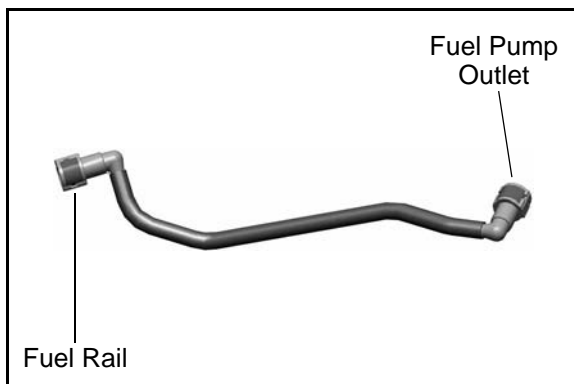

3. Pull out on the fuel line and remove it from the pump outlet.
4. To install the line, verify the connector and fuel pump outlet are clean and free of debris.
5. Place the connector end over the fuel pump outlet and push the white retainer and tabs back into place. **NOTE: Confirm attachment by pulling on the fuel line.**
6. Repeat this process when removing the fuel line from the fuel rail.

**EFI SERVICE NOTES**

For more convenient and accurate testing of EFI components, it is recommended dealers utilize the Digital Wrench™ Diagnostic Software (dealer only), or limited testing may be done manually using the procedures provided.

80% of all EFI problems are caused by wiring harness connections. Follow a common sense approach when diagnosing a potential EFI issue:

1. Disconnect the harness at the suspected sensor connector.
2. Inspect the connector ends for damage or contamination. If damaged, repair; if contaminated, clean. Reconnect and check function.
3. If problem persists, perform a sensor bench test according to the specific sensor requirements (if applicable).
4. If the sensor bench tests pass, disconnect the connector at the ECU and perform a continuity check between the sensor connector and the appropriate pin at the ECU connector (all connections for that sensor). Wiring resistance should be less than one (1) ohm.
5. If the resistance is high (or open), a wiring harness inspection is required (including a thorough inspection of the ECU connector for contamination or damage).
6. If the sensor passes and the wiring passes inspection, and reconnecting the ECU does not resolve the issue, then at that point a known-good ECU (from another Polaris 850) may be used to test for problem resolution.
 - Never attempt to service any fuel system component while engine is running or ignition switch "on".
 - **USE CARE** when removing or installing the ECU connector, as well as all other harness connections on the unit. Properly connect and disconnect the ECU harness to minimize damage to the connector pins and locking mechanism.
 - Although every precaution has been taken to prevent water intrusion failure, avoid direct water or spray contact with system components.
 - Do not disconnect or reconnect the wiring harness connector to the ECU or any individual components with the ignition "on." This can send a damaging voltage spike through the ECU.
 - Do not allow battery cables to touch opposite terminals.
 - Never start the engine when the cables are loose or poorly connected to the battery terminals.
 - Never disconnect battery while engine is running.
 - Always unplug ECU from the wire harness before performing any welding on the unit.

ELECTRONIC FUEL INJECTION

EFI SYSTEM LAYOUT

Exploded View

1. Electronic Control Unit (ECU)
2. Temperature / Manifold Absolute Pressure Sensor (T-MAP)
3. Idle Air Control (IAC)
4. Crankshaft Position Sensor (CPS)
5. Fuel Injectors
6. Fuel Rail
7. Fuel Line (quick connect)
8. Fuel Pump / Regulator / Fuel Gauge Sender (inside fuel tank)
9. Engine Coolant Temperature Sensor (ECT)
10. Throttle Position Sensor (TPS)
11. Throttle Body
12. Ignition Coil

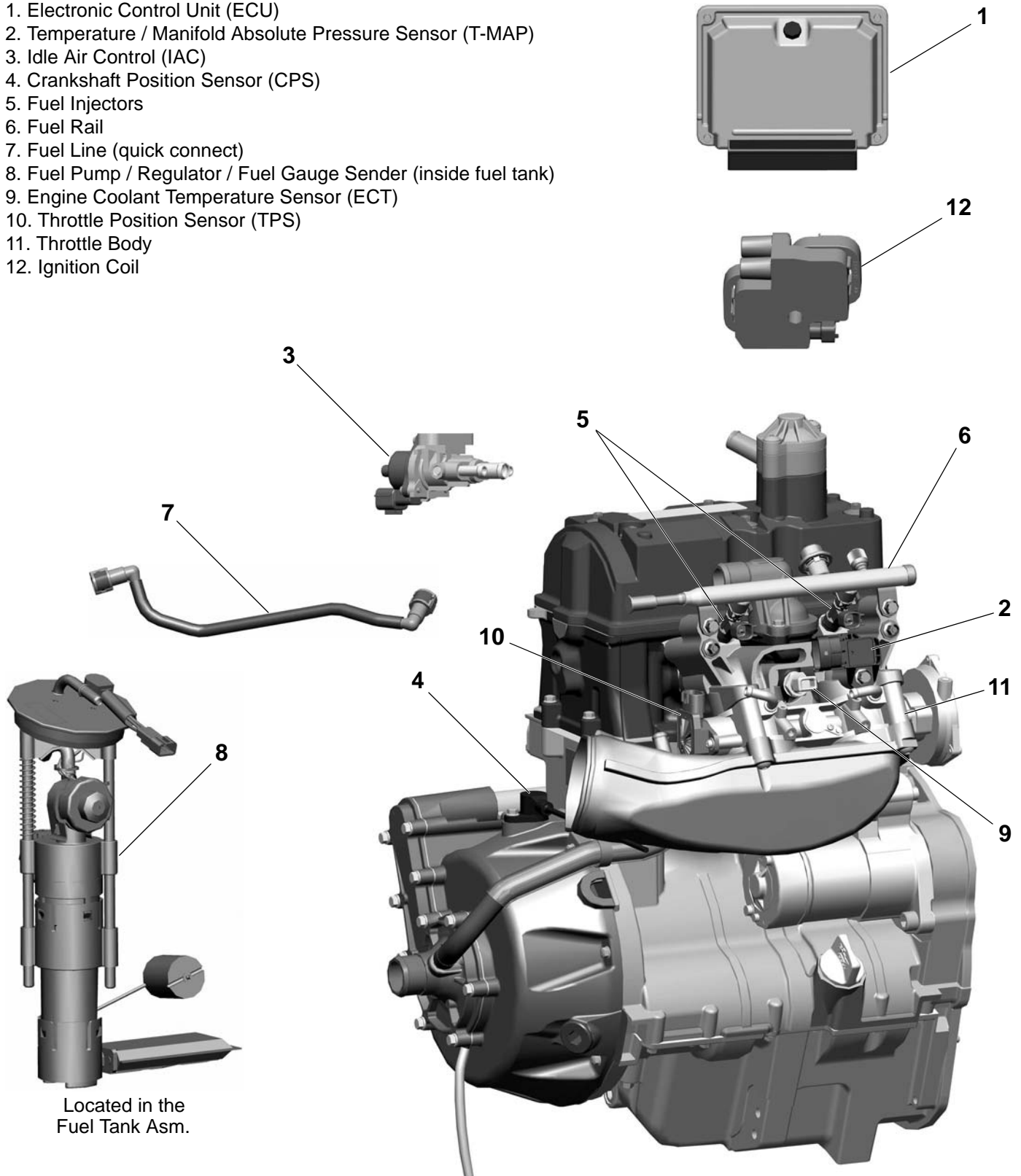

EFI COMPONENTS**Identification / Location**

- Electronic Control Unit (ECU)**
- Attached to the air box, located behind the LH side panel.

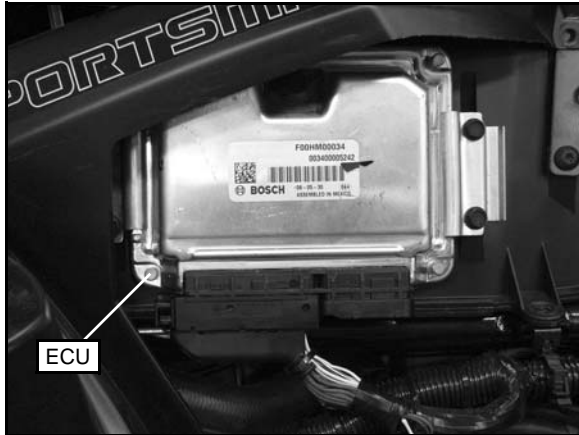

- Temperature and Manifold Absolute Pressure Sensor (T-MAP)**
- Located in the Integrated Air Fuel Manifold (IAFM).

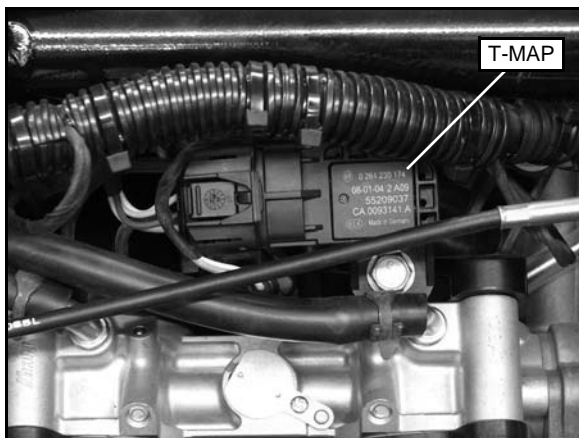

- Idle Air Control (IAC)**
- Located in front of the engine behind the frame support.

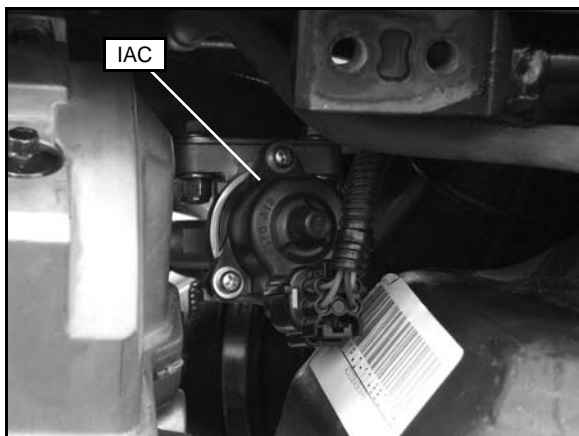

- Crankshaft Position Sensor (CPS)**
- Located in the top portion of the magneto cover on the front of the engine.

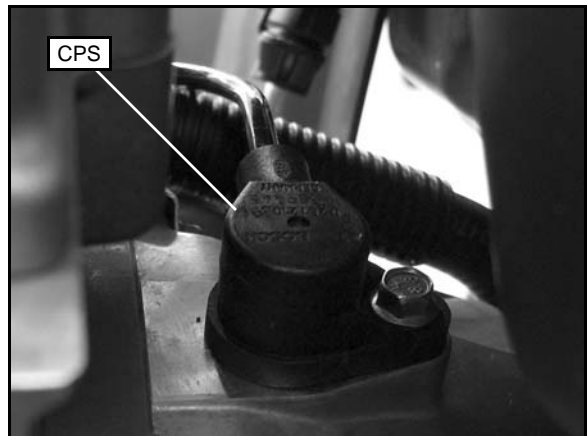

- Fuel Injectors**
- Located in the Integrated Air Fuel Manifold (IAFM).

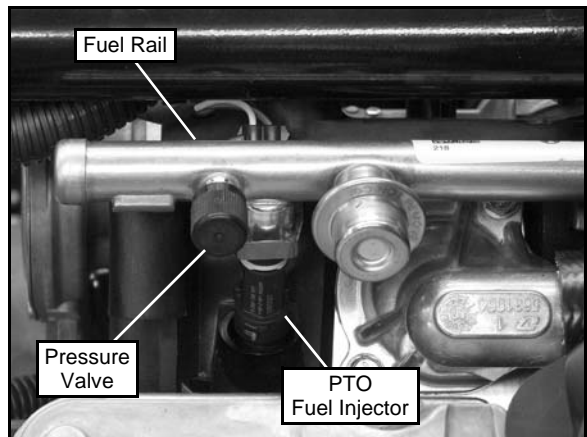

- Fuel Rail / Fuel Pressure Valve**
- Attached to the top portion of the fuel injectors.
- Located on the PTO end of the fuel rail.
- Fuel Line (Quick Connect)**
- Located between the injector fuel rail and the fuel tank.

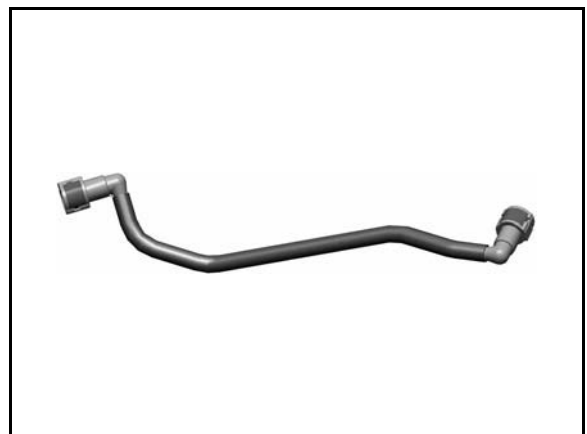

ELECTRONIC FUEL INJECTION

8. Fuel Pump / Regulator / Fuel Gauge Sender Assembly

- Located behind the right-hand side panel.

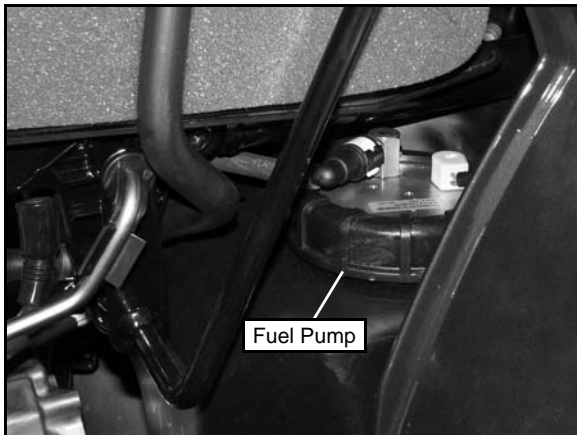

- Located in the fuel tank as an assembly.

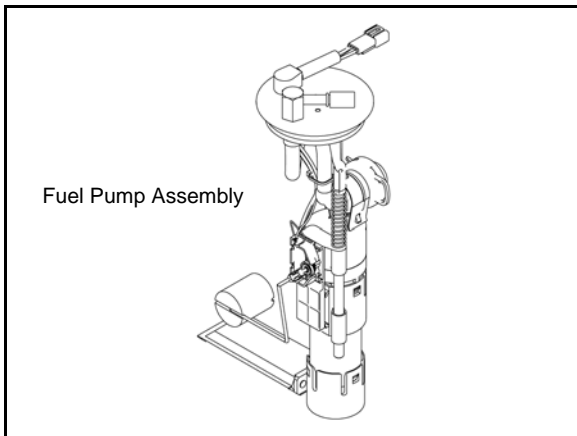

9. Engine Coolant Temperature Sensor (ECT)

- Located in the cylinder head below the thermostat housing, just above the throttle body.

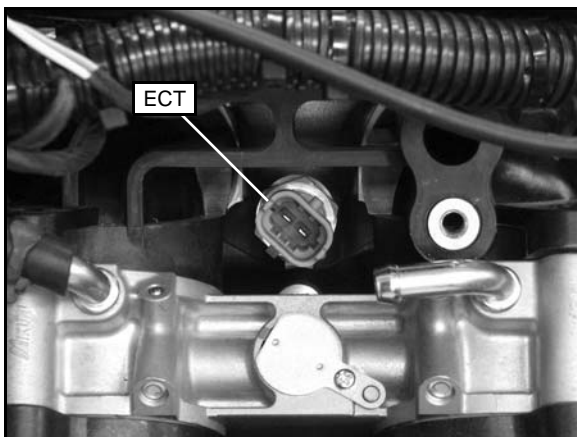

10. Throttle Position Sensor (TPS)

- Located on the MAG end (front) of the throttle body.

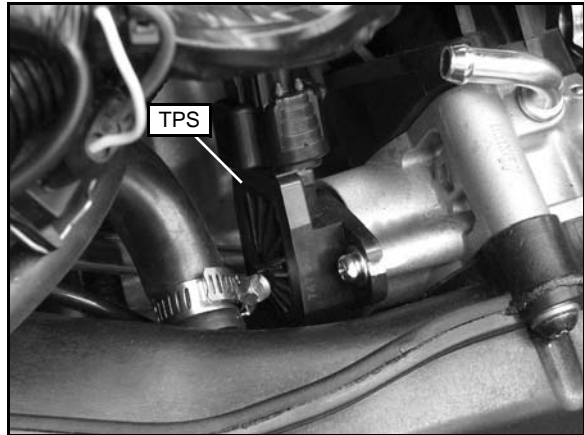

11. Throttle Body

- Attached between the IAFM and the intake plenum.

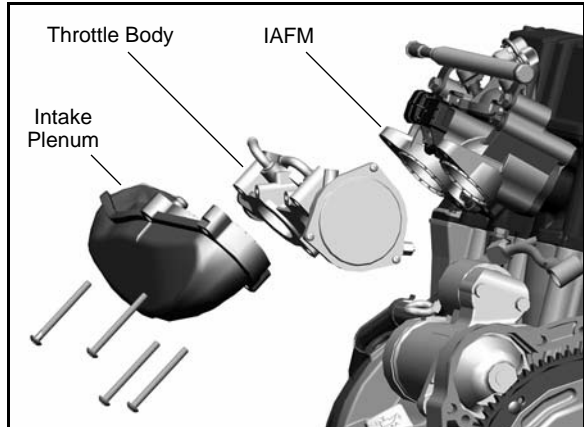

12. Ignition Coil

- Located on the RH side of the airbox. The high tension leads are retained by the airbox.

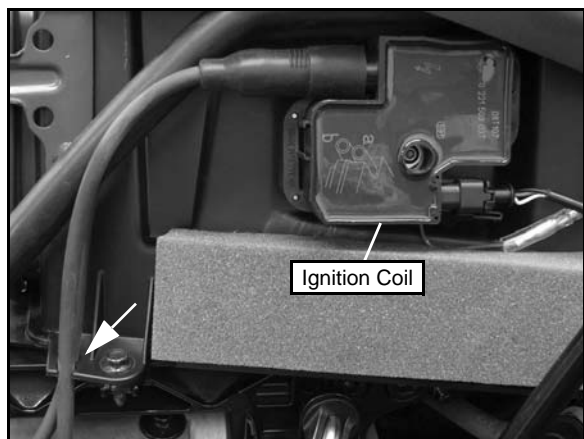

ELECTRONIC FUEL INJECTION**General Information**

The Electronic Fuel Injection (EFI) system is a complete engine fuel and ignition management design. This system includes the following principal components:

- Fuel Pump / Fuel Filters / Pressure Regulator
- Fuel Line
- Fuel Rail
- Fuel Injectors
- Throttle Body / Integrated Air Fuel Manifold (IAFM)
- Electronic Control Unit (ECU)
- Ignition Coil
- Engine Coolant Temperature Sensor (ECT)
- Throttle Position Sensor (TPS)
- Crankshaft Position Sensor (CPS)
- Intake Air Temperature / Manifold Absolute Pressure Sensor (T-MAP)
- Idle Air Control (IAC)
- Wire Harness Assembly

EFI Operation Overview

The EFI system is designed to provide peak engine performance with optimum fuel efficiency and lowest possible emissions. The ignition and injection functions are electronically controlled, monitored and continually corrected during operation to maintain peak performance.

The central component of the system is the Bosch Engine Control Unit (ECU) which manages system operation, determining the best combination of fuel mixture and ignition timing for the current operating conditions.

An in-tank electric fuel pump is used to move fuel from the tank, through the fuel line, to the fuel rail. The in-tank fuel pressure regulator maintains a system operating pressure of 43 psi and returns any excess fuel to the tank. At the engine, fuel is fed through the fuel rail and into the injectors, which inject into the intake ports. The ECU controls the amount of fuel by varying the length of time that the injectors are "on." This can range from 1.5-8.0 milliseconds depending on fuel requirements. The controlled injection of the fuel occurs every other crankshaft revolution, or once for each 4-stroke cycle. The total amount of fuel needed for one firing of a cylinder is injected during each cycle. When the intake valve opens, the fuel/air mixture is drawn into the combustion chamber, ignited and burned.

The ECU controls the amount of fuel being injected and the ignition timing by monitoring the primary sensor signals for intake air temperature, manifold absolute pressure (load), engine temperature, speed (RPM), and throttle position. These primary signals are compared to the programming in the ECU computer chip, and the ECU adjusts the fuel delivery and ignition timing to match the values.

During operation the ECU has the ability to re-adjust temporarily, providing compensation for changes in overall engine condition and operating environment, so it will be able to maintain the ideal air/fuel ratio.

During certain operating periods such as cold starts, warm up, acceleration, etc., a richer air / fuel ratio is automatically calculated by the ECU.

Initial Priming / Starting Procedure

NOTE: The injection system must be purged of all air prior to the initial start up, and / or any time the system has been disassembled.

If the EFI system is completely empty of fuel or has been disassembled and repaired:

1. Cycle the key switch from "OFF" to "ON" 6 times, waiting for approximately 3 seconds at each "ON" cycle to allow the fuel pump to cycle and shut down.
2. Once step 1 is completed, turn the key switch to "START" until the engine starts or 5 seconds has passed.
3. If the engine failed to start, repeat step 1 for 2 more cycles and attempt to start the engine.

If the engine fails to start, a problem may still exist, and should be diagnosed.

NOTE: Accurate testing of EFI components is recommended utilizing the Digital Wrench™ Diagnostic Software (dealer only).

ELECTRONIC FUEL INJECTION

ELECTRONIC CONTROL UNIT (ECU)

Operation Overview

The ECU is the brain or central processing computer of the entire EFI fuel/ignition management system. During operation, sensors continuously gather data which is relayed through the wiring harness to input circuits within the ECU. Signals to the ECU include: ignition (on/off), crankshaft position and speed (RPM), throttle position, engine coolant temperature, intake air temperature, intake manifold air pressure and battery voltage.

The ECU compares the input signals to the programmed maps in its memory and determines the appropriate fuel and spark requirements for the immediate operating conditions. The ECU then sends output signals to set the injector duration and ignition timing.

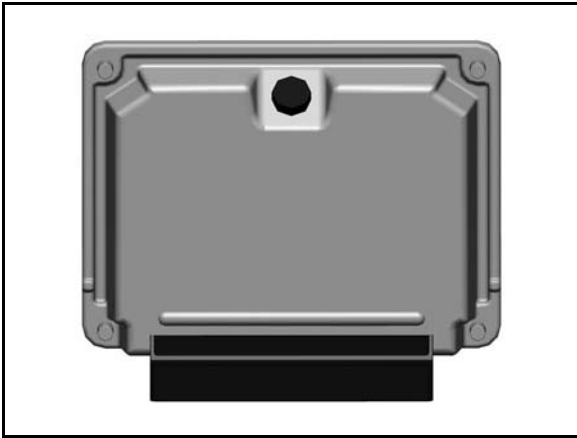

During operation, the ECU continually performs a diagnostic check of itself, each of the sensors, and system performance. If a fault is detected, the ECU turns on the "Check Engine" light in the speedometer and stores the fault code in its fault memory. Depending on the significance or severity of the fault, normal operation may continue, or "Fail-Safe" operation (slowed speed, richer running) may be initiated. A technician can determine the cause of the "Check Engine" light by initiating the "Blink Code" sequence or by using Digital Wrench™. The ECU requires a minimum of 7.0 volts to operate. The memory in the ECU is operational the moment the battery cables are connected.

To prevent engine over-speed and possible failure, an RPM-limiting feature is programmed into the ECU. If the maximum RPM limit (8000) is exceeded, the ECU suppresses the injection signals, cutting off the fuel flow. This process repeats itself in rapid succession, limiting operation to the preset maximum.

Maximum RPM Limit: 8000

SPORTSMAN XP 850 RPM Limit:

Hard Limit - Fuel injector suppression occurs

- All Gears: 8000 RPM

Soft Limit - Spark timing suppression occurs

- All Gears: 7500 RPM

ECU Service

Never attempt to disassemble the ECU. It is sealed to prevent damage to internal components. Warranty is void if the case is opened or tampered with in any way.

All operating and control functions within the ECU are pre-set. No internal servicing or readjustment may be performed. If a problem is encountered, and you determine the ECU to be faulty, contact the Polaris Service Department for specific handling instructions. Do not replace the ECU without factory authorization.

The relationship between the ECU and the throttle position sensor (TPS) is very critical to proper system operation. If the TPS is faulty, or the mounting position of the TPS to the throttle body is altered, the TPS must be adjusted.

For the purpose of troubleshooting, a known-good ECU from another Polaris Sportsman XP 850 of the same model may be used without system or engine component damage.

ECU Removal / Replacement

1. Remove the seat and upper left-hand side panel (see Chapter 9 "Seat and Side Panels").
2. With the ignition turned off, disconnect the wire harness from the ECU by pulling the black slider out away from the ECU while pulling down on the connector. Once the slider is fully extended, pull the connector from the ECU, using care not to damage the connector or locking mechanism.



3. Remove the (4) screws retaining the ECU to the airbox and remove the ECU.

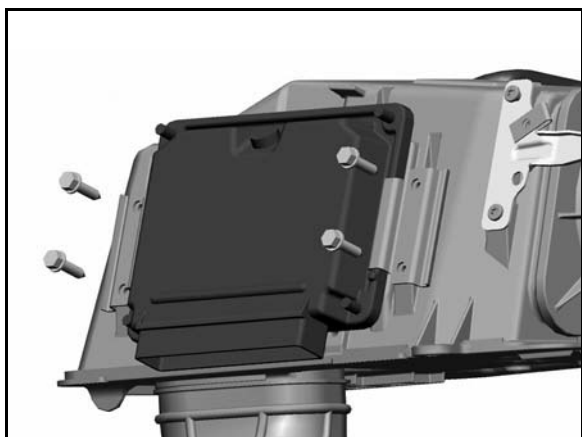

4. To install, reverse the previous steps. **DO NOT** apply dielectric grease to the connector, as it is a sealed connector. Tighten screws to **10 in. lbs. (1.1 Nm)**.

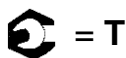

ECU Retaining Screws
10 in. lbs. (1.1 Nm)

IMPORTANT: If replacing the ECU, you must reflash the new ECU with the correct calibration upon installation and prior to attempting to start the vehicle.

FUEL PUMP

Operation

NOTE: All EFI units utilize quick connect fuel lines.

An electric fuel pump assembly is used to transfer fuel to the EFI system from inside the fuel tank. This assembly includes the fuel pump, regulator and fuel gauge sender. The pump is rated for a minimum output of 25 liters per hour at 43 psi and has a non-serviceable preliminary 65-micron filter.

Fuel pump is not serviceable, picture for reference only.

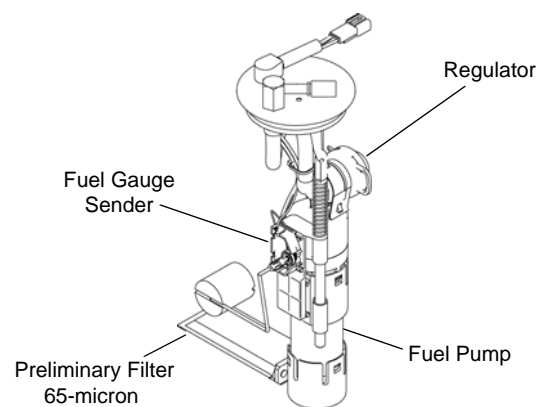

When the key switch is turned to "ON", the ECU activates the fuel pump, which pressurizes the system for start-up.

The ECU switches off the pump preventing the continued delivery of fuel in these instances:

- If the key switch is not promptly turned to the "start" position.
- If the engine fails to start.
- If the engine is stopped with the key switch "ON" (as in the case of an accident).

ELECTRONIC FUEL INJECTION

Fuel Sender Test

If the fuel gauge reading on the instrument cluster is not working, or if the display reading differs in large comparison to the fuel in the tank, perform a resistance test on the fuel sender.

Disconnect the fuel pump / sending unit connection and measure the resistance between the Purple and Brown wires. If out of specification, replace the fuel pump / tank assembly.

Fuel Sender Resistance Specifications:

Full: 6 Ω
Empty: 90 Ω

Fuel Pump Test

NOTE: The fuel pump / tank assembly is a non-serviceable assembly and must be replaced if determined to be faulty. If a fuel delivery problem is suspected, make certain the pump is being activated by the ECU and EFI relay, all electrical connections are properly secured, the 20A EFI fuse is good, and a minimum of 7.0 volts is being supplied.

CAUTION

Fuel is extremely flammable and may cause severe burns, injury, or death. Do not use any device that produces a flame or electrical devices that may spark around fuel or fuel vapors.

1. Couple the Fuel Pressure Gauge Adaptor (PS-48762) to the Fuel Pressure Gauge Kit (PU-43506-A).

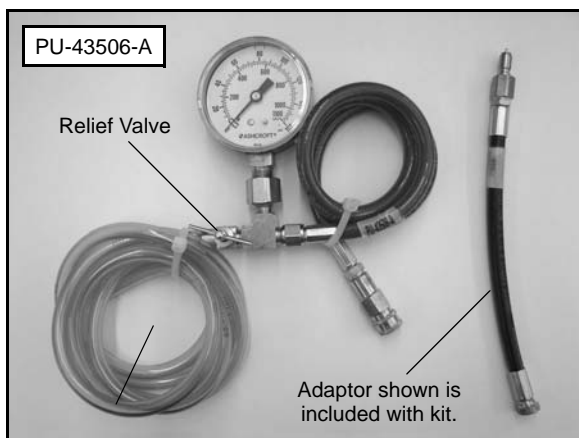

2. Locate the fuel pressure valve attached to the fuel rail.

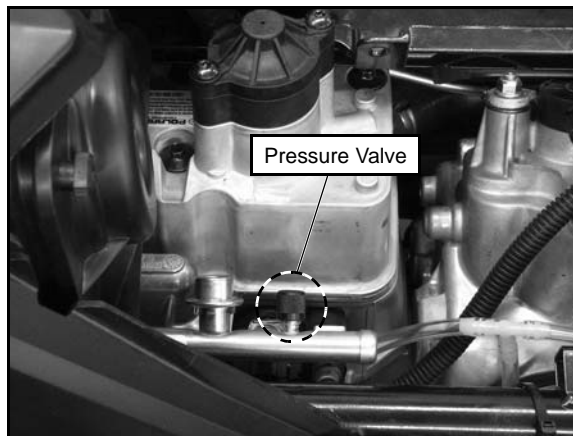

3. Remove the black cap and attach the fuel pressure gauge kit and adaptor to the pressure valve. Route the clear hose into a portable gasoline container or the vehicle's fuel tank.
4. Turn on the key switch to activate the pump and check the system pressure on the gauge. If system pressure of 43 psi \pm 3 is observed, turn the key switch "off" and depress the valve button on the tester to relieve the system pressure.

Fuel Pump Pressure: 43 psi \pm 3

NOTE: If the fuel pressure is out of specification, replace the fuel pump / tank assembly.

5. If the pump did not activate (Step 4), disconnect the plug from the fuel pump. Connect a DC voltmeter across terminals "A" and "C" in the plug on the vehicle harness side. Turn on the key switch and observe voltage to ensure a minimum of 7 volts is present.

NOTE: If the voltage was below 7 VDC, test battery, ignition switch, EFI relay and wiring harness.

6. If the reading is between 7 and 14 volts, turn key switch off and connect an ohmmeter between the terminals "A" and "C" in the plug on the pump harness to check for continuity within the fuel pump.

NOTE: If there was no continuity between the pump terminals, replace the fuel pump / tank assembly.

7. If voltage at the plug was within the specified range, and there was continuity across the pump terminals, reconnect the plug to the pump, making sure you have clean connections. Turn on the key switch and listen for the pump to activate.

NOTE: If the pump starts, verify you have the correct amount of fuel pressure.

8. If the pump still does not operate, check ECU operation by plugging in a known-good ECU of the same model.

NOTE: If the pump still does not operate, replace the fuel pump / tank assembly.

Fuel Pump / Fuel Tank Removal

IMPORTANT: Syphon as much fuel from the tank as possible before attempting to remove it from the ATV.

⚠ WARNING

Always wear safety goggles when working with high pressure or flammable fluids. Failure to do so could result in serious injury or complications.

NOTE: The fuel pump cannot be replaced as an individual component, the entire fuel pump and fuel tank must be replaced as an assembly. Refer to the “Electronic Parts Catalog” for the proper part number.

1. Remove the seat and both upper side panels (see Chapter 9 “Seat and Side Panels”).
2. Disconnect the negative battery cable.
3. Remove the (4) push rivets from each front mud guard and remove the guards from the vehicle (see Chapter 9 “Mud Guards”).
4. Remove the front rack assembly (see Chapter 9 “Front Rack”).
5. Remove the front cab assembly (see Chapter 9 “Front Cab”).

IMPORTANT: Be sure to cover the fuel tank inlet with a shop towel prior to front cab and fuel tank removal (see Chapter 9 “Front Cab”).

6. Remove the (4) screws from the bottom of the right-hand footwell.
7. Remove the (2) fuel tank mounting screws located on the upper portion of the fuel tank.

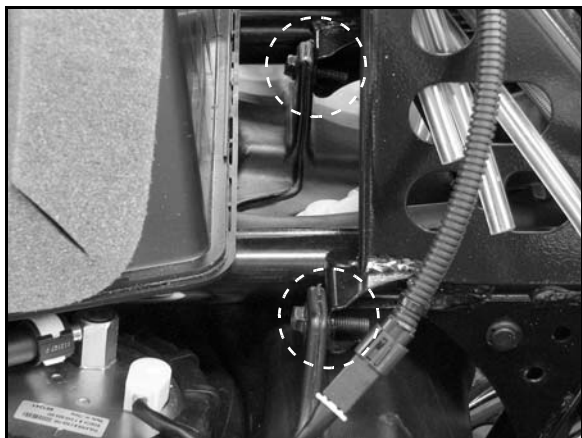

8. Remove the vent line from the fitting on top of the fuel tank.

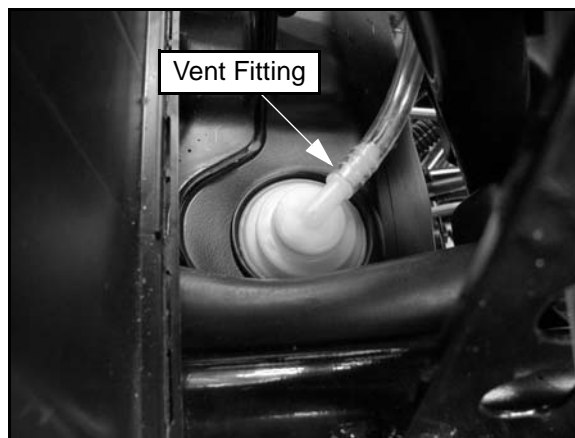

9. Disconnect the fuel pump electrical harness.

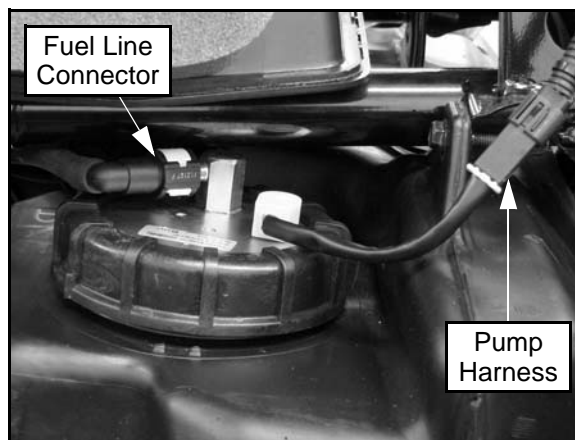

10. While holding a shop towel over the fuel line connector, disconnect the quick connect fuel line from the fuel pump.

NOTE: A small amount of fuel may come out of the fuel line or tank. Properly drain fuel into a suitable container.

11. Carefully pull the fuel tank out the right side of the ATV.



ELECTRONIC FUEL INJECTION

Fuel Pump / Fuel Tank Installation

1. Reinstall the fuel tank assembly through the right side.
2. Connect the fuel line to the fuel pump outlet and connect the fuel pump electrical harness.
3. Reinstall the vent line to the tank fitting.
4. Install the (2) fuel tank mounting screws and tighten securely.
5. Install the (4) screws into the bottom portion of the right-hand footwell.
6. Install the front cab assembly (see Chapter 9 "Front Cab").
7. Remove the shop towel from the fuel tank inlet, reconnect the fuel fill hose and tighten hose clamp securely.
8. Install the front rack assembly (see Chapter 9 "Front Rack").
9. Install the front mud guards (see Chapter 9 "Mud Guards").
10. Reconnect the negative cable to the battery.
11. Install the upper side panels and seat (see Chapter 9 "Seat and Side Panels").
12. Test the fuel pump by turning on the key and listening for the pump to activate.

FUEL PRESSURE REGULATOR

Operation Overview

The fuel pressure regulator maintains the required operating system pressure of 43 psi \pm 3 psi. A rubber-fiber diaphragm divides the regulator into two separate sections, the fuel chamber and the pressure regulating chamber. The pressure regulating spring presses against the valve holder (part of the diaphragm), pressing the valve against the valve seat. The combination of atmospheric pressure and regulating spring tension equals the desired operating pressure. Any time the fuel pressure against the bottom of the diaphragm exceeds the desired (top) pressure, the valve opens, relieving the excess pressure, returning the excess fuel back to the tank.

Fuel Pressure Regulator Test

Refer to the "Fuel Pump Test" procedure.

Fuel Pressure Regulator Replacement

The regulator is a sealed, non-serviceable assembly. If it is faulty, the fuel tank assembly must be replaced. Refer to the "Fuel Pump / Tank Assembly Replacement" procedure.

FUEL INJECTORS

Operation Overview

The fuel injectors mount into the Integrated Air Fuel Manifold (IAFM), and the fuel rail attaches to the top end of them. Replaceable O-rings on both ends of the injector prevent external fuel leaks and also insulate it from heat and vibration.

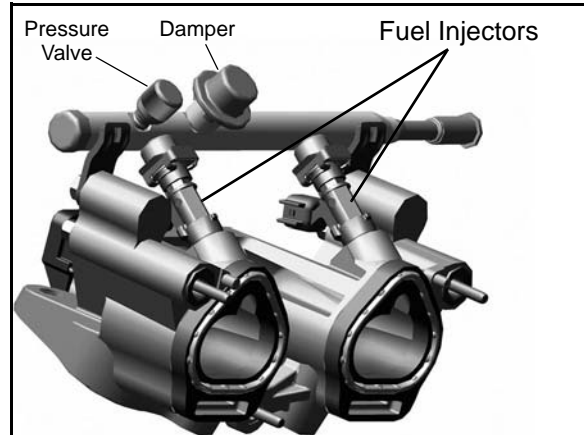

When the key switch is on, the fuel rail is pressurized, and the EFI relay provides voltage to the injectors. During engine operation, the ECU completes the ground circuit, energizing the injectors. The valve needle in the injector is opened electromagnetically, and the pressure in the fuel rail forces fuel down through the inside. The "director plate" at the tip of the injector contains a series of calibrated openings which directs the fuel into the intake port in a cone-shaped spray pattern.

The amount of fuel injected is controlled by the ECU and determined by the length of time the valve needle is held open, also referred to as the "injection duration" or "pulse width". It may vary in length depending on the speed and load requirements of the engine.

Fuel Injector Service

Injector problems typically fall into three general categories—electrical, dirty / clogged, or leakage. An electrical problem usually causes one or both of the injectors to stop functioning. Several methods may be used to check if the injectors are operating.

NOTE: Do not apply voltage directly to the fuel injectors. Excessive voltage will burn out the injectors. Do not ground the injectors with the ignition on. The injectors will open if the EFI relay is energized.

If an injector is not operating, it can indicate either a bad injector, or a wiring/electrical connection problem. Check as follows:

Injector leakage is very unlikely, but in rare instances it can be internal (past the tip of the valve needle), or external (weeping around the injector body). The loss of system pressure from the leakage can cause hot restart problems and longer cranking times.

Injector problems due to dirt or clogging are unlikely due to the design of the injectors, the high fuel pressure, the use of filters and the detergent additives in the gasoline. Symptoms that could be caused by dirty/clogged injectors include rough idle, hesitation/stumble during acceleration, or triggering of fault codes related to fuel delivery. Injector clogging is usually caused by a buildup of deposits on the director plate, restricting the flow of fuel, resulting in a poor spray pattern. Some contributing factors to injector clogging include; dirty air filters, higher than normal operating temperatures, short operating intervals and dirty, incorrect, or poor quality fuel. Cleaning of clogged injectors is not recommended; they should be replaced. Additives and higher grades of fuel can be used as a preventative measure if clogging has been a problem.

Fuel Injector Test

If an injector is not operating, it can indicate either a bad injector, or a wiring/electrical connection problem. Check as follows:

- Remove the seat, left-hand side panel, and disconnect the fuel injector(s).
- Using an ohmmeter, test for continuity by placing the test leads on each pin of the injector.
- Resistance specification is $13.8\Omega - 15.2\Omega$ (20°C , 68°F)

Fuel Injector Resistance Specification:
 $13.8\Omega - 15.2\Omega$ (20°C , 68°F)

Fuel Injector Replacement

NOTE: Engine must be cool. Depressurize the fuel system if possible.

1. Remove the seat and both upper side panels (see Chapter 9 "Seat and Side Panels").
2. Remove the (2) screws retaining the lower portion of the air box.
3. Remove the hose from the breaker valve located on top of the valve cover.
4. Remove the spark plug wires.
5. Remove the (2) Torx-head screws retaining the upper portion of the air box to the front cab.

6. Carefully disconnect the ECU by pulling the tab out while pulling down on the connector.
7. Loosen the hose clamp retaining the intake boot to the intake plenum and remove the boot.
8. Lift up on the air box and turn it sideways to gain access to the fuel rail and fuel injectors.
9. Thoroughly clean the area around the fuel rail and injectors.
10. Disconnect the "quick connect" fuel line from the fuel rail.
11. Disconnect the harness from both fuel injectors.
12. Using a 10 mm wrench, remove the fuel rail mounting screws.
13. Carefully pull up on the fuel rail and fuel injectors and remove them from the vehicle as an assembly.

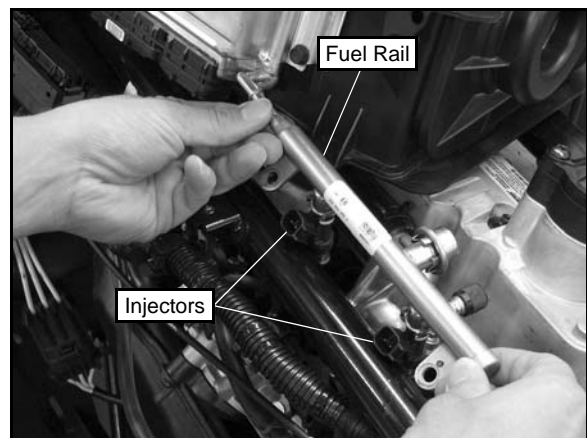

14. Pry the two injector retaining tabs open and remove the injector(s) from the fuel rail.

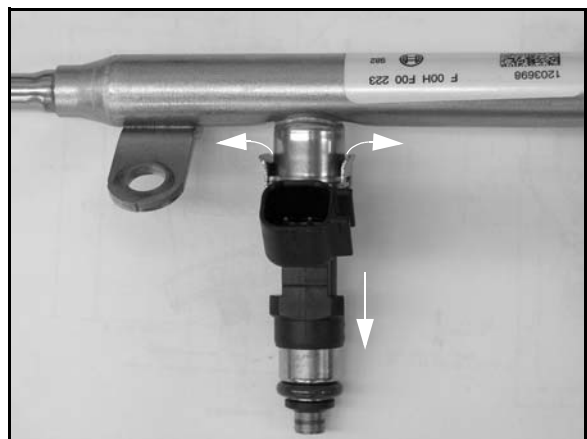

NOTE: Use new O-rings (included with new injector) any time an injector is removed.

15. Lubricate the O-rings lightly with soapy water to aid installation.
16. Install the new injector and torque the fuel rail mounting screws to **6 - 9 ft. lbs. (8 - 12 Nm)**.

ELECTRONIC FUEL INJECTION

CRANKSHAFT POSITION SENSOR (CPS)

Operation Overview

The engine speed sensor is essential to engine operation, constantly monitoring the rotational speed (RPM) and position of the crankshaft.

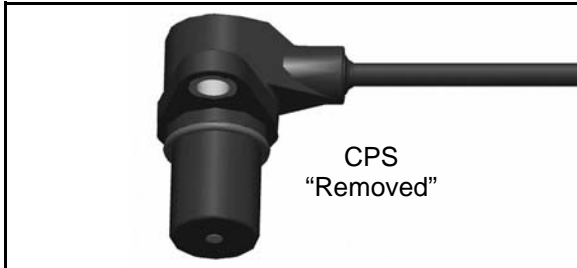

A ferromagnetic 60-tooth ring gear with two consecutive teeth missing is mounted on the flywheel. The inductive speed sensor is mounted 1.0 ± 0.26 mm (0.059 ± 0.010 in.) away from the ring gear. During rotation, an AC pulse is created within the sensor for each passing tooth. The ECU calculates engine speed from the time interval between the consecutive pulses. The two-tooth gap creates an “interrupt” input signal, corresponding to specific crankshaft position. This signal serves as a reference for the control of ignition timing by the ECU. Synchronization of the CPS and crankshaft position takes place during the first two revolutions each time the engine is started. This sensor must be properly connected at all times. If the sensor fails or becomes disconnected for any reason, the engine will stop running.

CPS Test

The crankshaft position sensor is a sealed, non-serviceable assembly. If fault code diagnosis indicates a problem with the CPS, test and correct as follows:

1. Remove the seat and left-hand side panel.
2. Locate and disconnect the CPS harness connector on the left side of the vehicle just below the ECU.

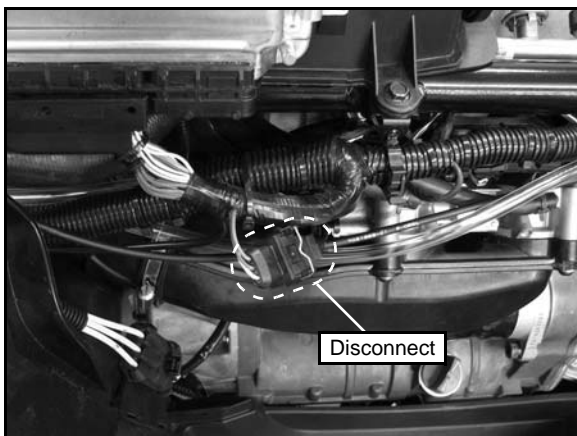

3. Connect an ohmmeter between the pin terminals as shown. A resistance value of $860 \Omega \pm 10\%$ at room temperature (20°C , 68°F) should be obtained.

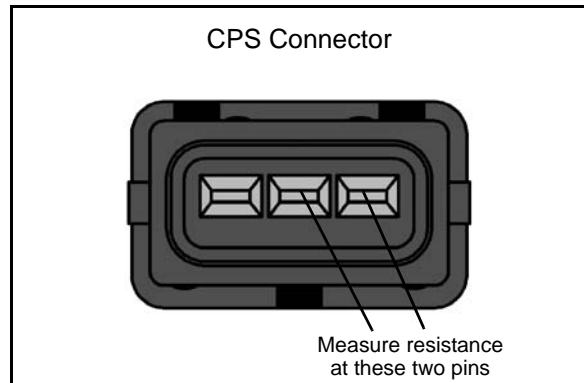

4. If resistance is correct, check the mounting, toothed ring gear (damage, runout, etc.), and flywheel key.

**Crankshaft Position Sensor:
 $860\Omega \pm 10\%$ (20°C , 68°F)**

CPS Replacement

1. Disconnect sensor harness connector (see “CPS Test”).
2. Using a 6 mm hex wrench, remove the retaining bolt and remove the sensor from the magneto cover.

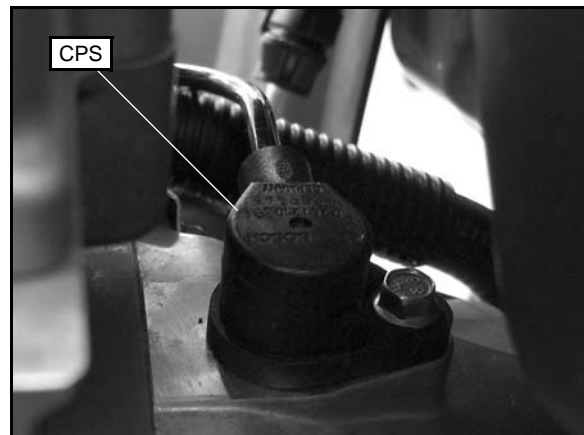

3. Install the new sensor using a light coating of oil on the O-ring to aid installation.
4. Torque the retaining bolt to specification.

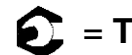

**CPS Retaining Bolt Torque:
7 ft. lbs. (10 Nm)**

TEMP / MANIFOLD ABSOLUTE PRESSURE SENSOR (T-MAP)

Operation Overview

Mounted on the (IAFM), the temperature and manifold absolute pressure sensor (T-MAP) performs two functions in one unit.

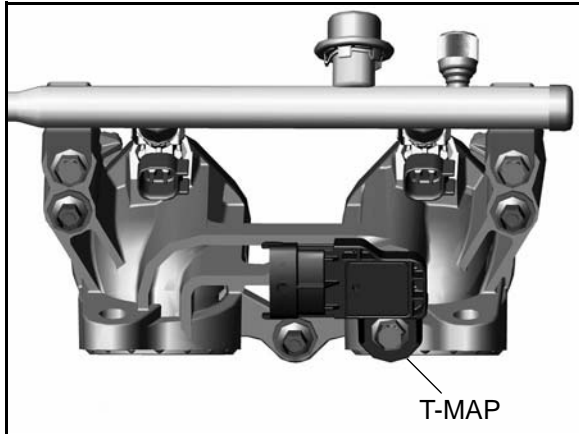

Air passing through the intake is measured by the T-MAP and relayed to the ECU. These signals, comprised of separate air temperature and manifold absolute pressure readings, are processed by the ECU and compared to its programming for determining the fuel and ignition requirements during operation.

T-MAP Test

The temperature and manifold absolute pressure sensor (T-MAP) is a non-serviceable item. If it is faulty, it must be replaced. This sensor requires a 5 Vdc input to operate, therefore the T-MAP sensor should only be tested using the Digital Wrench™ Diagnostic Software (dealer only).

T-MAP Replacement

1. Disconnect the sensor from the main harness.
2. Using a 10 mm wrench, remove the retaining bolt and sensor.
3. Install the new sensor using a light coating of oil on the O-ring to aid installation.
4. Torque the retaining bolt to specification.

 = T
**T-MAP Retaining Bolt Torque:
35-53 in. lbs. (4-6 Nm)**

IDLE AIR CONTROL VALVE (IAC)

Operation Overview

The Idle Air Control (IAC) is used to stabilize the idle quality of the engine at cold start-up and after warm-up operations.

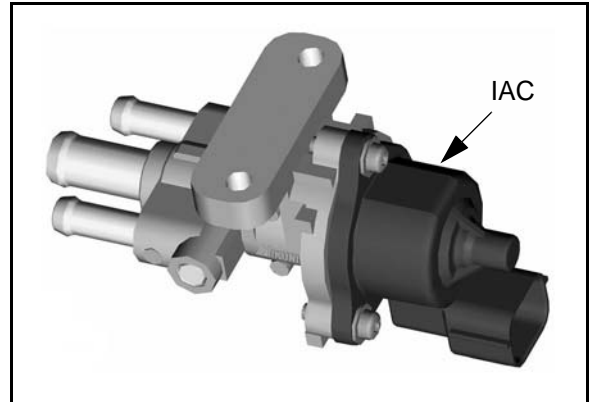

Mounted in front of the engine, the IAC contains 1 stepper motor which receives varying voltage signal pulses from the ECU. These pulses determine the IAC plunger setting, thereby controlling the amount of air bypassing the closed throttle body for idle control. If the IAC is disconnected or inoperative, it will remain at it's last operated position.

IAC Test

The IAC is a non-serviceable item. If it is faulty, it must be replaced. It can be 'bench tested' using the following method:

Set your meter to read Ohms. Check the resistance values at each of the following pin locations of the IAC. If any of the readings are out of specification, replace the IAC

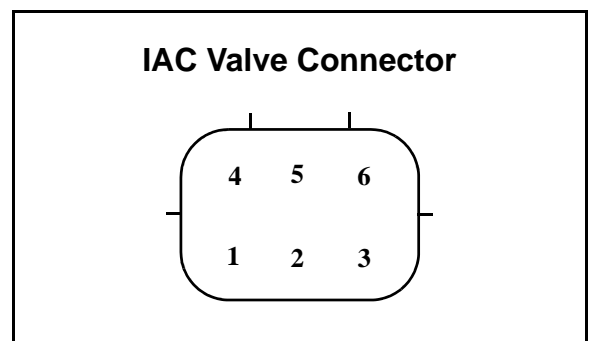

IAC Resistance Readings

Pins	Resistance	Pins	Resistance
1 - 2	30Ω ± 1.2Ω	4 - 5	30Ω ± 1.2Ω
2 - 3	30Ω ± 1.2Ω	5 - 6	30Ω ± 1.2Ω
1 - 3	60Ω ± 2.4Ω	4 - 6	60Ω ± 2.4Ω

ELECTRONIC FUEL INJECTION

IAC Replacement

1. Remove the seat and upper right-hand side panel (see Chapter 9 "Seat and Side Panels").
2. Disconnect the shift linkage from the shift lever.
3. Remove the spark plug wires.
4. Remove the retaining screw from the lower right-hand side of the airbox.
5. Remove the push rivets retaining the right-hand portion of the rear cab to gain access to the bolts retaining the upper right-hand frame support.
6. Remove the (4) bolts retaining the upper right-hand frame support. Pull the support forward and down to remove it from the vehicle.

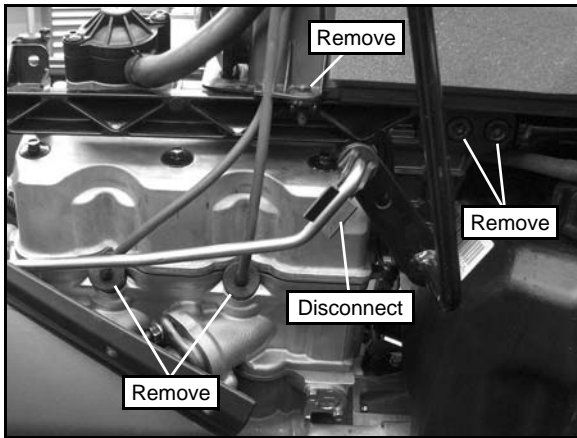

7. Disconnect vehicle harness from IAC.

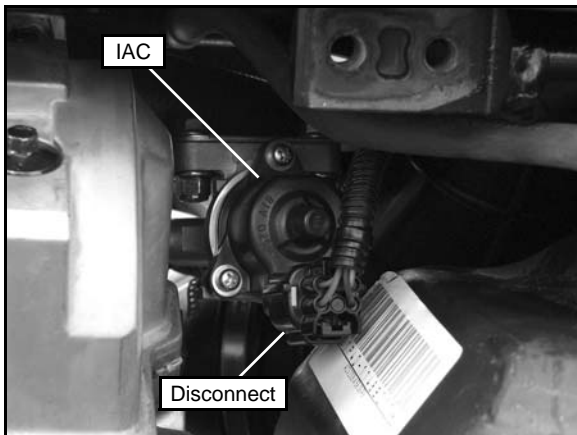

8. Remove the (3) Phillips-head mounting screws and remove the IAC from the housing.



9. Install the new IAC and torque the mounting screws to **17.7 in. lbs. (2 Nm)**.

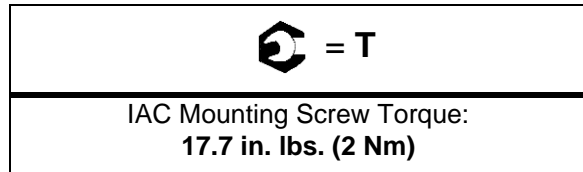

10. Reconnect vehicle harness to IAC.
11. Reinstall the throttle body and securely tighten the hose clamps.
12. Reinstall the side panel and seat.

THROTTLE POSITION SENSOR (TPS)

Operation Overview

The throttle position sensor (TPS) is used to indicate throttle plate angle to the ECU.

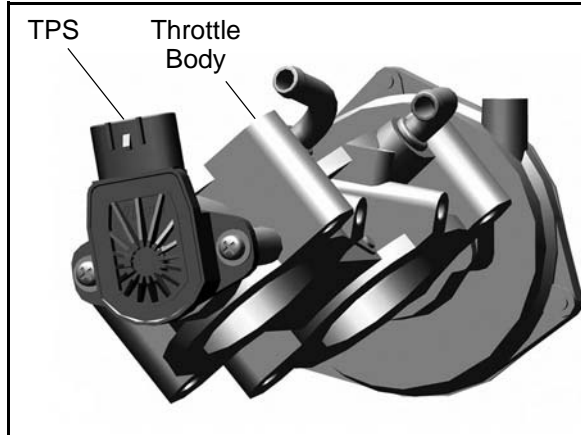

Mounted on the throttle body and operated directly off the end of the throttle shaft, the TPS works like a rheostat, varying the voltage signal to the ECU in direct correlation to the angle of the throttle plate. This signal is processed by the ECU and compared to the internal pre-programmed “maps” to determine the required fuel and ignition settings for the amount of engine load.

The correct position of the throttle body stop screw is established and set at the factory. DO NOT remove the tamper proof cap to adjust the throttle body stop screw or alter its position in any manner. The stop screw controls the air flow calibration of the throttle body.

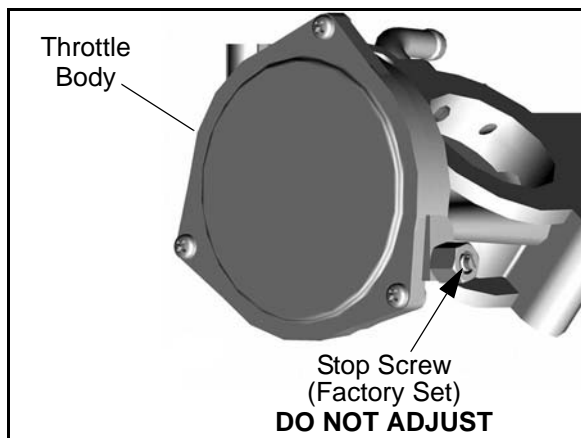

TPS Resistance Tests

The throttle position sensor (TPS) is a non-serviceable item. If it is faulty, it must be replaced. It can be tested using the following method:

Using an Ohm Meter:

With the test leads connected and the meter set to the ohms scale, observe the reading at the following pin locations of the TPS:

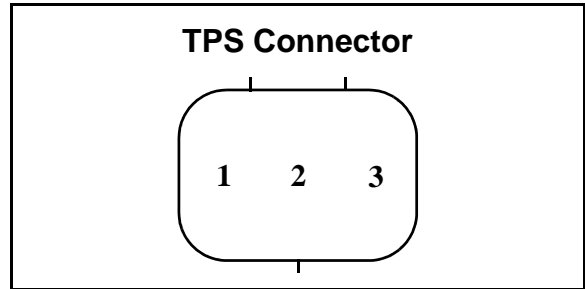

3

TPS Resistance Readings

Pins	Throttle Position	Resistance
②-GND	-----	∞
①-②	Closed	4kΩ - 5kΩ (reference)
①-②	Open	1150Ω - 1250Ω (reference)
①-③	-----	4kΩ - 6kΩ

TPS Tester Kit

The throttle position sensor (TPS) reading can be checked by using the TPS Tester Kit (2201519).

Set-up the TPS Tester Kit (2201519), according to the instructions that accompanied the tester. Make sure the 9 volt battery is new.

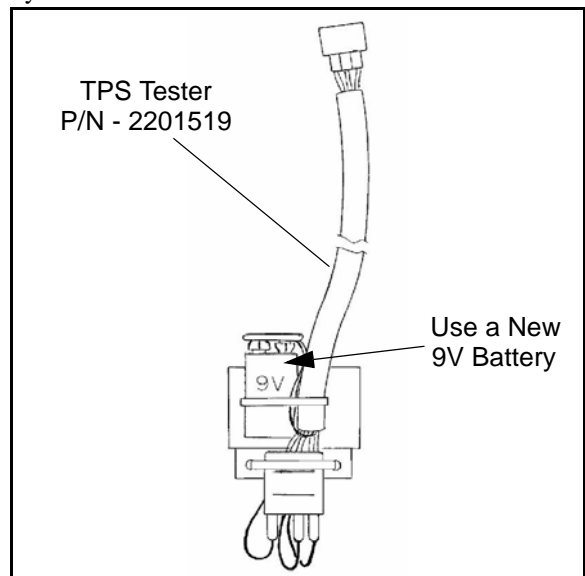

ELECTRONIC FUEL INJECTION

Verify TPS Tester Reference Voltage

A 5 volt reference voltage signal from the TPS Tester harness is required for the TPS test to be accurate. Refer to the instructions provided with the TPS Tester Kit (2201519) or follow the bullet point steps below to check reference voltage.

Reference Voltage Test:

- Insert black voltmeter probe into the “Bk” test port.
- Connect the red voltmeter probe into the “R” test port and verify the voltage is 4.99-5.01 Vdc. If this reading is low, verify the 9 volt battery is good or try a new 9 volt battery.

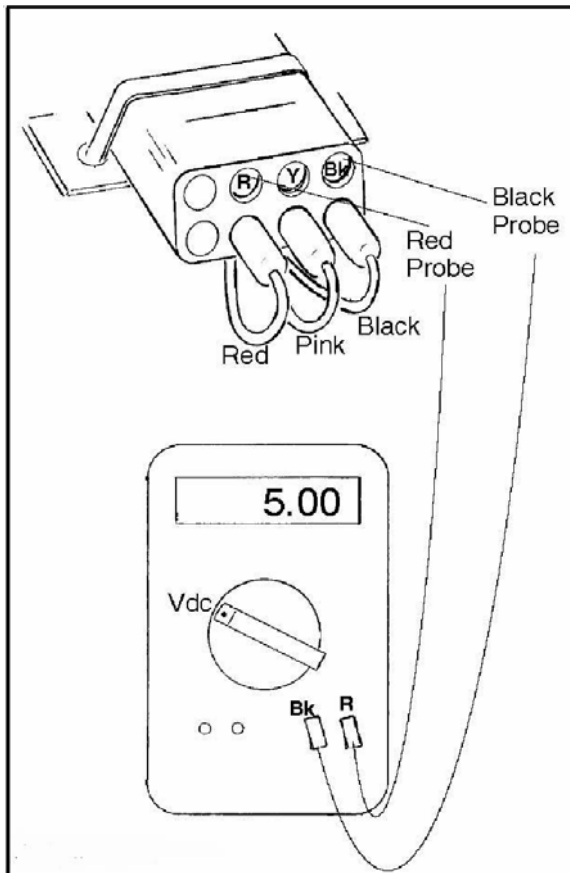

**TPS Reference Voltage
5 Vdc Input**

IMPORTANT: Always use a fresh 9 Volt battery.

Checking TPS Reading

1. Remove the seat and upper left-hand side panel (see Chapter 9 “Seat and Side Panels”).
2. Assemble the TPS Tester according to the instructions. Refer to “TPS Tester Kit” for proper set-up and testing. Verify the 9 volt tester battery is new.
3. Disconnect vehicle harness from TPS.

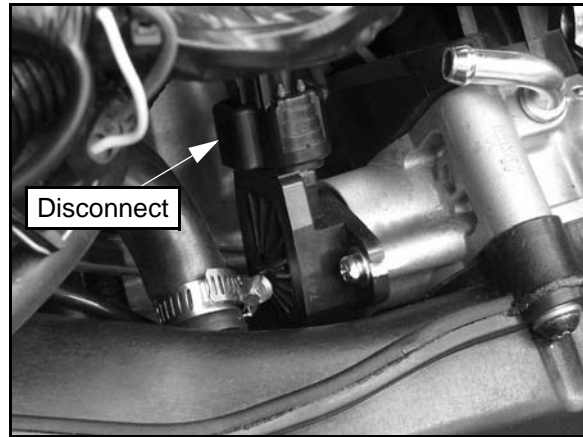

4. Plug the TPS Tester harness in the TPS harness.
5. Set your voltmeter to read Vdc. Connect the red voltmeter probe into the “R” test port and the black voltmeter probe into the “Y” test port (see Figure 3-20).

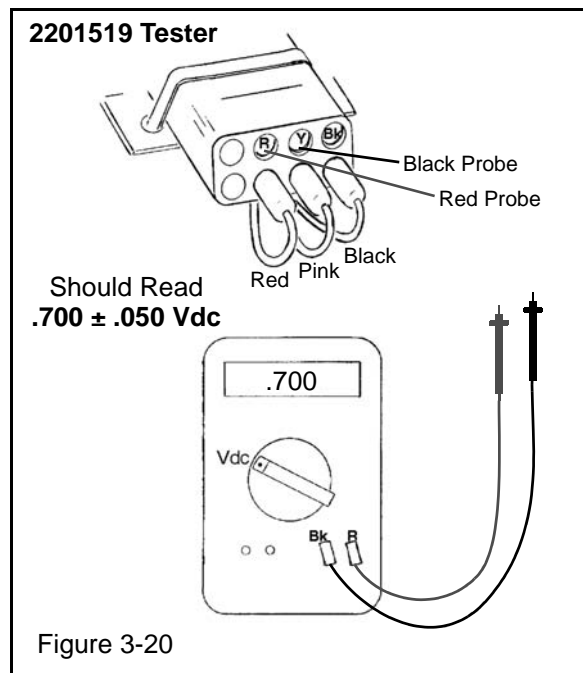

Figure 3-20

6. Move the throttle open and closed slowly while reading the display. The voltage should increase and decrease smoothly without any “jumps” when the throttle is applied.

7. If voltage varies with throttle movement, continue on to the next step. If the sensor did not function correctly, replace it.
8. Allow the throttle lever to rest in the idle position. The voltmeter should read $.700 \pm .050$ volts.

TPS Output Reading
 $.700 \pm .050$ Vdc

9. If the voltage does not read within the specification, proceed to the “**TPS Adjustment**” procedure. If the voltage reading is within specification, no adjustment is required.

TPS Adjustment

NOTE: This procedure should be performed after you have checked the TPS reading. Refer to “**Checking TPS Reading**” procedure before making any adjustments.

1. Loosen the hose clamp retaining the intake boot to the intake plenum.
2. Remove the (4) bolts retaining the intake plenum and throttle body.
3. Position the throttle body to access the TPS screws.
4. Make sure the TPS Tester harness is still connected to the TPS harness.
5. Loosen the TPS mounting screws.



6. Rotate the TPS until your voltmeter reads $.700 \pm .050$ volts (see Figure 3-20).

TPS Output Reading
 $.700 \pm .050$ Vdc

7. Retighten TPS mounting screws and torque to specification.



TPS Mounting Screws:
17.7 in. lbs. (2 Nm)

8. Verify voltage reading did not change. If voltage reading changed, repeat steps 5 - 7.
9. Reconnect the vehicle harness to the TPS.
10. Reinstall the throttle body and intake plenum. Torque bolts to specification.

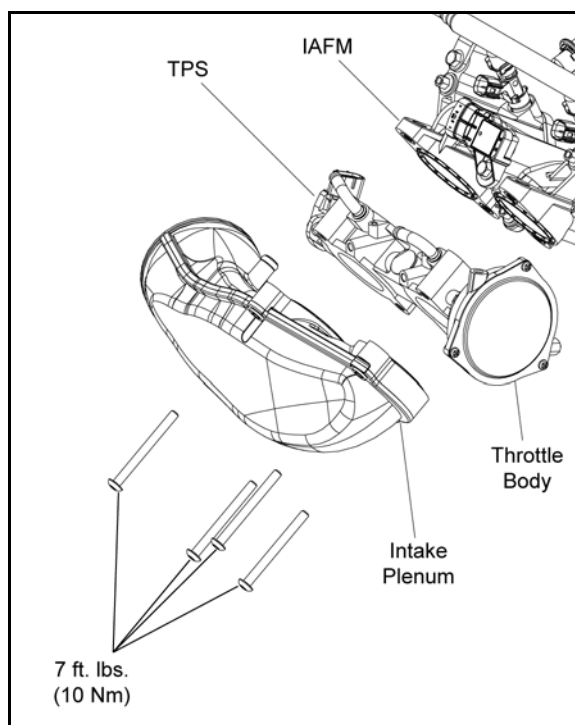

Intake Plenum Bolts:
7 ft. lbs. (10 Nm)

11. Install intake boot to intake plenum and securely tighten the hose clamp.
12. Reinstall the left-hand side panel and seat.
13. Start engine and test operation.

ELECTRONIC FUEL INJECTION

TPS Replacement

NOTE: The correct position of the TPS angle on the throttle body is established and set at the factory. If the TPS is replaced, repositioned or loosened it must be recalibrated. Refer to the “TPS Adjustment” procedure.

1. Remove the seat and upper left-hand side panel (see Chapter 9 “Seat and Side Panels”).
2. Loosen the hose clamp retaining the intake boot to the intake plenum.
3. Remove the (4) bolts retaining the intake plenum and throttle body.
4. Position the throttle body to access the TPS harness and mounting screws.
5. Disconnect the harness from the TPS.

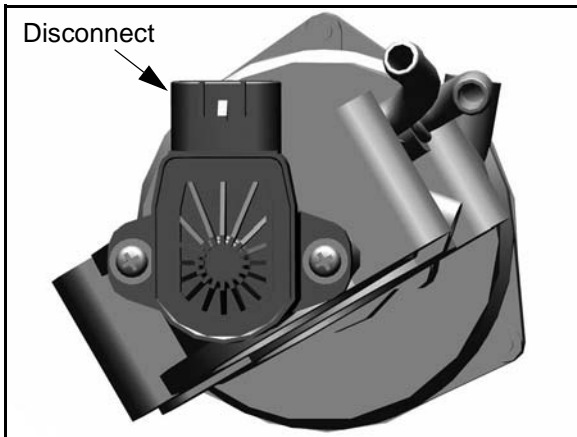

6. Remove the (2) Phillips-head mounting screws and replace the TPS.

IMPORTANT: If replacing the TPS or throttle body, you must perform the “TPS Adjustment” procedure.

7. Refer to “TPS Adjustment” for setting the TPS voltage.

ENGINE COOLANT TEMPERATURE SENSOR (ECT)

Operation Overview

The engine coolant temperature sensor measures coolant temperature. The engine temperature sensor is a Negative Temperature Coefficient (NTC) type sensor, as the temperature increases the resistance decreases.

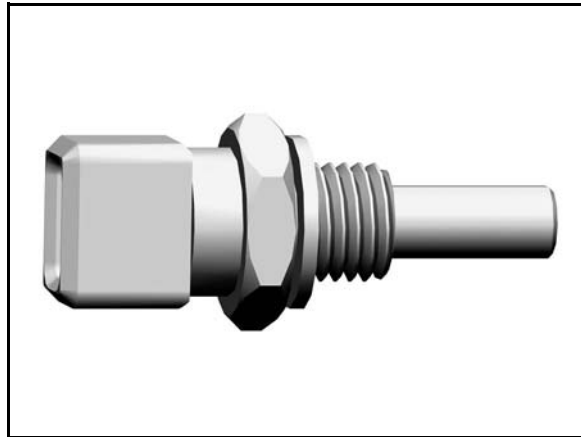

Coolant passes through the cylinder and by the sensor probe, varying a resistance reading which is relayed to the ECU. This signal is processed by the ECU and compared to its programming for determining the fuel and ignition requirements during operation. The ECU also uses this signal to determine when to activate the fan during operation.

ECT Sensor Test

To quickly rule out other components and wiring related to the ECT, disconnect the harness from the ECT sensor and start the engine. After a few seconds, the fan should turn on and the “Over Temp” indicator should display on the instrument cluster. This indicates all other components are working properly.

Refer to Chapter 4 for additional ECT information. Polaris dealers can test the sensor by using the Digital Wrench™ Diagnostic Software (dealer only).

ECT Sensor Resistance Readings

Temperature °F (°C)	Resistance
32 °F (0 °C)	5.9k Ω ± 5%
68 °F (20 °C)	2.5k Ω ± 5%
176 °F (80 °C)	323 Ω ± 5%
212 °F (100 °C)	186 Ω ± 5%

ECT Sensor Replacement

1. Drain coolant to level below sensor.
2. Disconnect the ECT sensor from engine harness. Remove the T-MAP sensor to allow access to the ECT sensor.

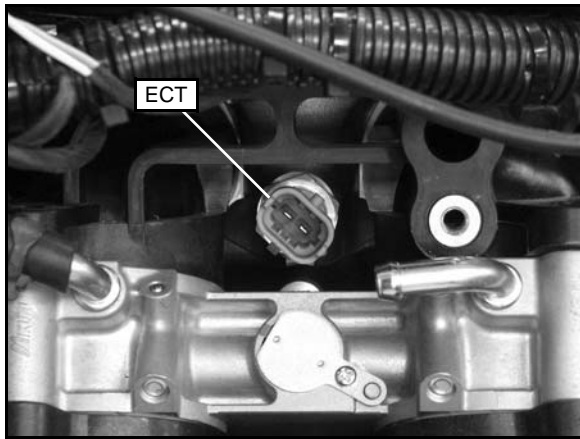

3. Remove and replace the sensor, applying a light coating of thread sealant to aid installation.
4. Torque the ECT sensor to specification.

 = T
ECT Sensor Torque: 17 ft. lbs. (23 Nm)

IGNITION COIL

Operation Overview

The ignition coil is used to provide high voltage to fire the spark plugs. When the ignition key is on, DC voltage is present in primary side of the ignition coil windings. During engine rotation, an AC pulse is created within the crankshaft position sensor for each passing tooth on the flywheel. The two-tooth gap creates an “interrupt” input signal, corresponding to specific crankshaft position. This signal serves as a reference for the control of ignition timing. The ECU then calculates the time interval between the consecutive pulses, and determines when to trigger the voltage spike that induces the voltage from the primary to the secondary coil windings to fire the spark plugs.

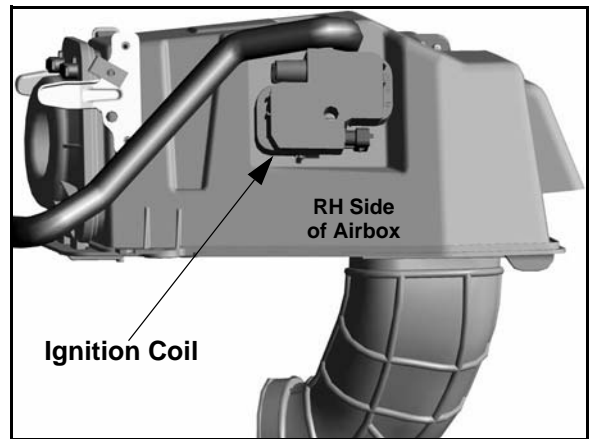

Ignition Coil Tests

The ignition coil can be tested by using an ohm meter. Use the following illustrations and specification table to test the ignition coil.

Remove the seat and upper right-hand side panel to access the ignition coil.

Ignition Coil Resistance Readings

Test	Pin Connection	Resistance
Primary	Between 1 & 2 Between 3 & 2	0.4 Ω
Secondary	Between High Tension Lead Ends	5 k Ω

ELECTRONIC FUEL INJECTION

Primary Test

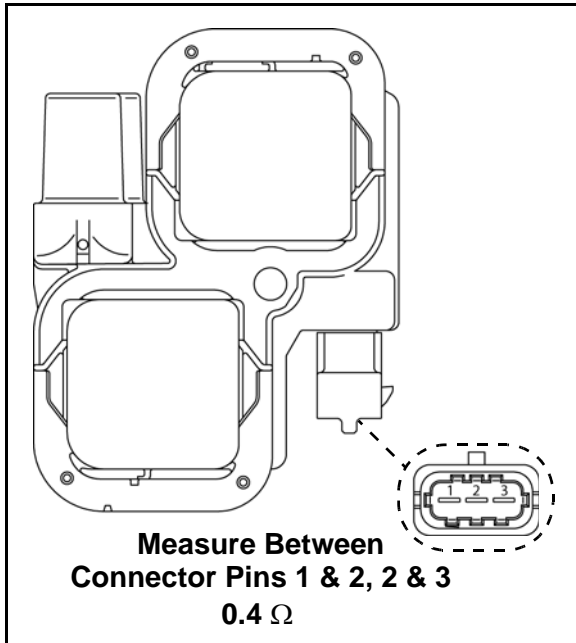

Secondary Test

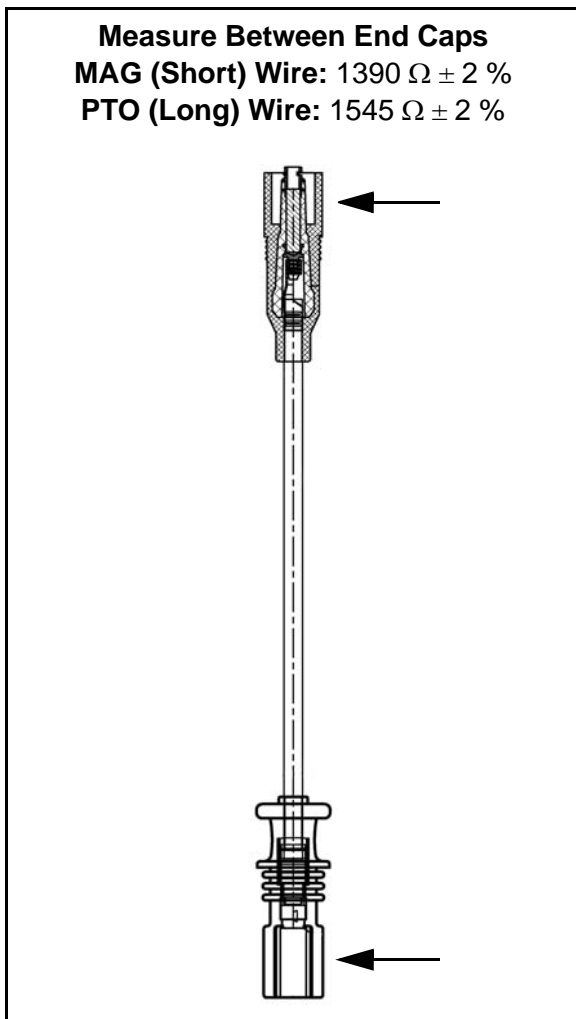

Ignition Coil and HT Lead Replacement

NOTE: The plug caps or coil ends are not removable. The high tension lead (coil wire) must be replaced as an assembly.

1. Remove the seat and upper right-hand side panel to access the ignition coil (see Chapter 9 "Seat and Side Panels").
2. Disconnect the shift linkage and remove the high tension lead caps from the spark plugs.
3. Remove the high tension leads from the airbox.
4. Disconnect the harness from the ignition coil.
5. Using a T20 driver, remove the screw retaining the ignition coil to the airbox.
6. Remove the coil assembly and disconnect the high tension leads by pulling on the coil side end caps.
7. Install the new high tension leads.

NOTE: Be sure to install the PTO (long) wire on the coil terminal nearest the airbox.

8. Install the coil assembly and securely tighten the mounting screw.
9. Upon assembly, make sure the high tension leads are retained by the airbox.



10. Reinstall the shift linkage, upper right-hand side panel and the seat.

EFI DIAGNOSTICS

Instrument Cluster Trouble Code Display

Use the following procedure to display diagnostic trouble codes logged in the ECU if the Check Engine (MIL) icon is illuminated on the instrument cluster.

NOTE: In order to view the diagnostic codes on the instrument cluster, the Check Engine (MIL) icon must be illuminated.

1. Place the transmission in PARK.
2. Turn the ignition switch to the "ON" position.
3. Toggle through the LCD display using the "SELECT" button until the Check Engine (MIL) icon begins flashing.
4. When the Check Engine (MIL) icon is flashing, a set of two numbers will appear on the LCD.
5. The first number is located in the information area and can be 2 to 6 digits in length. This number represents the Suspect Parameter Number (SPN).
6. The second number is located in the clock area and can be 1 to 2 digits in length. This number represents the Failure Mode Identifier (FMI).

7. Use the "Diagnostic Trouble Code Table" as a reference.
8. Press and hold the "MODE" button to cycle through all currently active trouble codes.

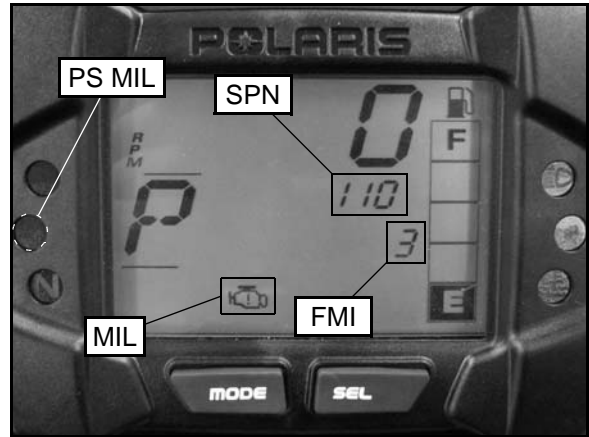

NOTE: On vehicles equipped with power steering, the power steering (MIL) LED will illuminate and blink in place of the Check Engine (MIL) if there is a diagnostic problem with the power steering system.

DIAGNOSTIC TROUBLE CODE TABLE

Component	Condition	SPN Suspect Parameter Number	FMI Failure Mode Identifier
Throttle Position Sensor (TPS)	Voltage Too High	51	3
	Voltage Too Low	51	4
Engine Temperature Sensor (ECT)	Voltage Too High	110	3
	Voltage Too Low	110	4
	Temperature Too High	110	16
	Engine Overheat Shutdown	110	0
Intake Air Temperature (T-MAP)	Voltage Too High	105	3
	Voltage Too Low	105	4
Manifold Absolute Pressure Sensor (T-MAP)	Voltage Too High	102	3
	Voltage Too Low	102	4
	Signal Out of Range	102	2
Crankshaft Position Sensor (CPS)	Circuit Fault	636	8
	Plausibility Fault	636	2
Vehicle Speed Signal	Plausibility Fault	84	2
Gear Sensor Signal	Voltage Too Low	523	4
	Voltage Too High	523	3
	Signal Fault	523	2

ELECTRONIC FUEL INJECTION**DIAGNOSTIC TROUBLE CODE TABLE**

Component	Condition	SPN Suspect Parameter Number	FMI Failure Mode Identifier
Injector 1 (MAG)	Driver Circuit Open / Grounded	651	5
	Driver Circuit Short to B+	651	3
	Driver Circuit Grounded	651	4
Injector 2 (PTO)	Driver Circuit Open / Grounded	652	5
	Driver Circuit Short to B+	652	3
	Driver Circuit Grounded	652	4
Ignition Coil Primary Driver 1 (MAG)	Driver Open / Grounded	1268	3
Ignition Coil Primary Driver 2 (PTO)	Driver Circuit Short to B+	1269	3
Fuel Pump Driver Circuit	Driver Circuit Open / Grounded	1347	5
	Driver Circuit Short to B+	1347	3
	Driver Circuit Grounded	1347	4
Fan Relay Driver Circuit	Driver Circuit Open / Grounded	1071	5
	Driver Circuit Short to B+	1071	3
	Driver Circuit Grounded	1071	4
Idle Air Control (IAC)	Driver Circuit Open / Grounded	634	5
	Driver Circuit Short to B+	634	3
	Driver Circuit Grounded	634	4
	Position Out of Range	634	7
Starter Enable Circuit	Driver Circuit Open / Grounded	1321	5
	Driver Circuit Short to B+	1321	3
	Driver Circuit Grounded	1321	4
Chassis Relay	Driver Circuit Open / Grounded	520208	5
	Driver Circuit Short to B+	520208	3
	Driver Circuit Grounded	520208	4
All Wheel Drive Control (AWD)	Driver Circuit Open / Grounded	520207	5
	Driver Circuit Short to B+	520207	3
	Driver Circuit Grounded	520207	4
System Power	Voltage Too High	168	3
	Voltage Too Low	168	4
Throttle Safety Signal	Voltage Too High	520194	3
	Voltage Too Low	520194	4
	Signal Out of Range	520194	2
	Throttle Stuck	520194	7
Active Descent Control (ADC)	Driver Circuit Open / Grounded	520203	5
	Driver Circuit Short to B+	520203	3
	Driver Circuit Grounded	520203	4

DIAGNOSTIC TROUBLE CODE TABLE

Component	Condition	SPN Suspect Parameter Number	FMI Failure Mode Identifier
Idle Speed	Speed Too High	520211	3
	Speed Too Low	520211	4
Calibration	Checksum/CRC Error	630	13
Steering Over Current Shut Down	Current Above Normal or Grounded	520221	6
Steering Excessive Current Error	Current Above Normal or Grounded	520222	6
Steering Torque or Speed Sensor Partial Failure	Condition Exists	520223	31
Steering Torque or Speed Sensor Full Failure	Condition Exists	520224	31
EPAS Inverter Temperature	Greater than 110° C (230° F)	520225	16
	Greater than 120° C (248° F)	520225	0
EPAS CAN Communications Receive Error	No RX Message for 2 Seconds	520226	2
EPAS CAN Communications Transmit Error	No TX Message for 2 Seconds	520227	2
Vehicle Speed (This is applicable when the EPAS module gets the vehicle speed from the ECM)	Received Vehicle Speed Has Error	84	19
Engine Speed (This is applicable when the EPAS module gets the engine speed from the ECM)	Received Engine Speed Has Error	190	19
Battery Voltage	Too High	168	3
	Too Low	168	4
Position Encoder Error		520228	11
EPAS Software Error	Software Error Illegal Memory Access	520229	12
	Software Error Stack Overrun	520229	12
	Software Error Illegal Peripheral Interrupt	520229	12
IC CAN Communication with EPAS	EPAS Off Line (EPAS DM1 not seen)	520230	31
EEProm: Read/Write Failure		628	12

ELECTRONIC FUEL INJECTION

FUEL SYSTEM TROUBLESHOOTING

The correct position of the throttle body stop screw is established and set at the factory. DO NOT remove the tamper proof cap to adjust the throttle body stop screw or alter its position in any manner. The stop screw controls the air flow calibration of the throttle body.

Fuel Starvation / Lean Mixture

Symptoms: Hard start or no start, bog, backfire, popping through intake / exhaust, hesitation, detonation, low power, spark plug erosion, engine runs hot, surging, high idle, idle speed erratic.

- No fuel in tank
- Restricted tank vent, or routed improperly
- Fuel lines or fuel injectors restricted
- Fuel pump inoperative
- Air leak in system
- Intake air leak (throttle shaft, intake boot, gasket or grommet)
- Throttle stop screw tampering
- Failed sensor or disconnected wiring

Rich Mixture

Symptoms: Fouls spark plugs, black, sooty exhaust smoke, rough idle, poor fuel economy, engine runs rough/ misses, poor performance, bog, engine loads up, backfire.

- Air intake restricted (inspect intake duct)
- Air filter dirty/plugged
- Poor fuel quality (old fuel)
- Fouled spark plug
- TPS setting incorrect
- Injector failure
- Failed sensor or disconnected wiring
- Throttle stop screw tampering

Poor Idle

Symptom: Idle Too High (If greater than 1400 RPM when engine is warm)

- Throttle stop screw tampering
- Throttle cable sticking, improperly adjusted, routed incorrectly
- Failed sensor or disconnected wiring
- IAC stuck or inoperative
- Intake air leak

Symptom: Idle Too Low (if less than 1100 RPM when engine is warm)

- Plugged air filter
- Leaking injector (rich condition)
- Belt dragging
- Throttle stop screw tampering
- Failed sensor or disconnected wiring

Symptom: Erratic Idle

- Throttle cable incorrectly adjusted
- Air Leaks, dirty injector
- TPS damaged or misadjusted
- Tight valves
- Belt dragging
- Dirty air cleaner
- Engine worn
- Spark Plug fouled
- Throttle stop screw tampering
- Failed sensor or disconnected wiring

EFI SYSTEM BREAK-OUT DIAGRAMS

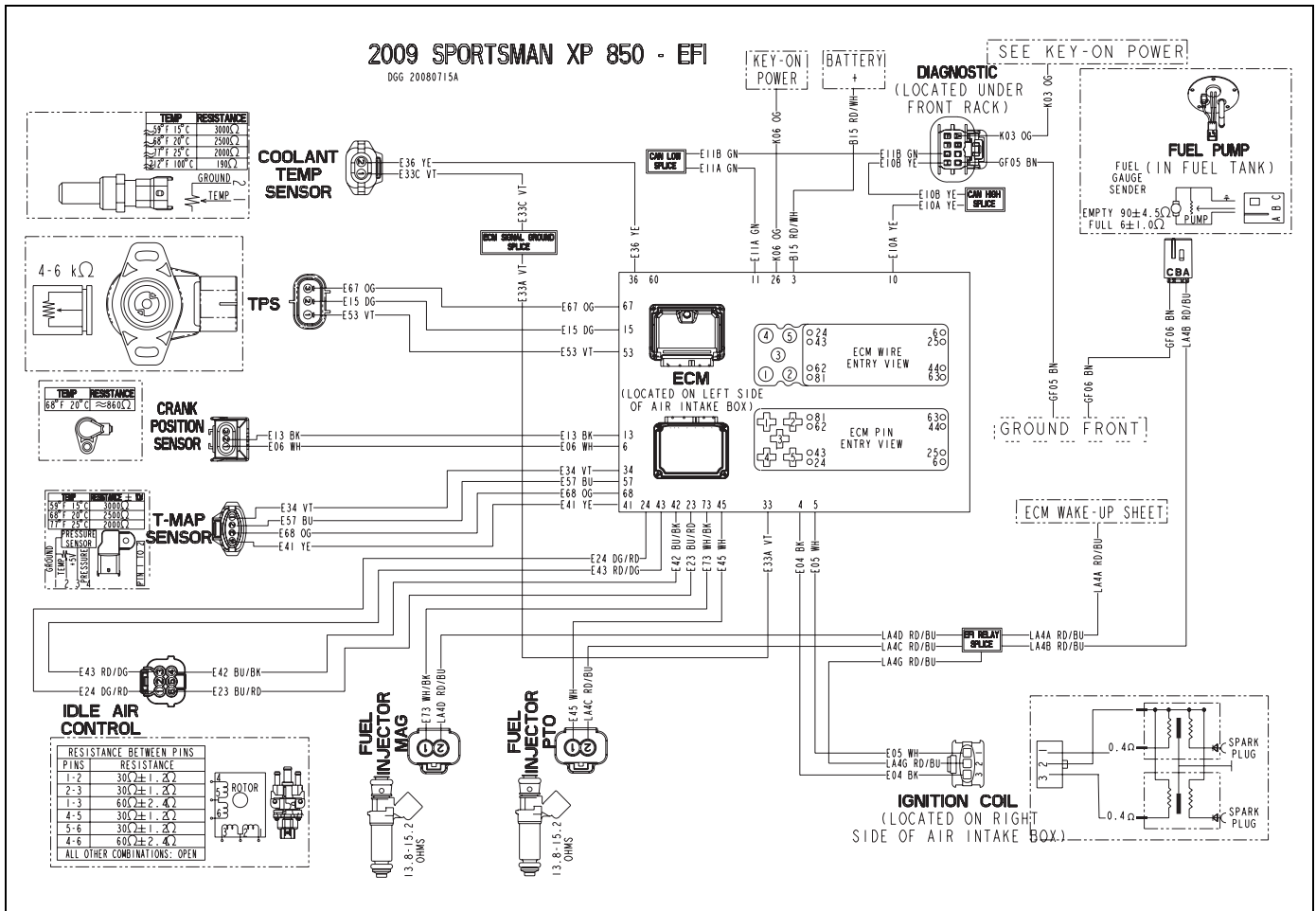

ELECTRONIC FUEL INJECTION

Fuel Injector Circuit (PTO)

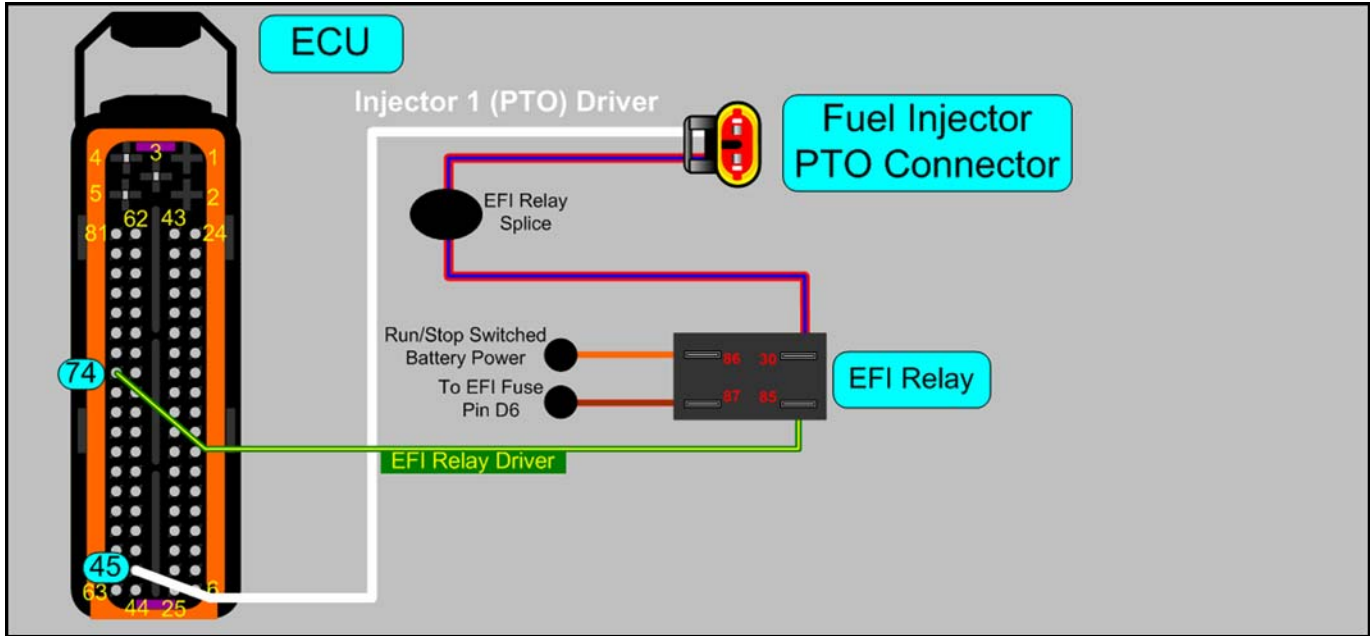

Fuel Injector Circuit (MAG)

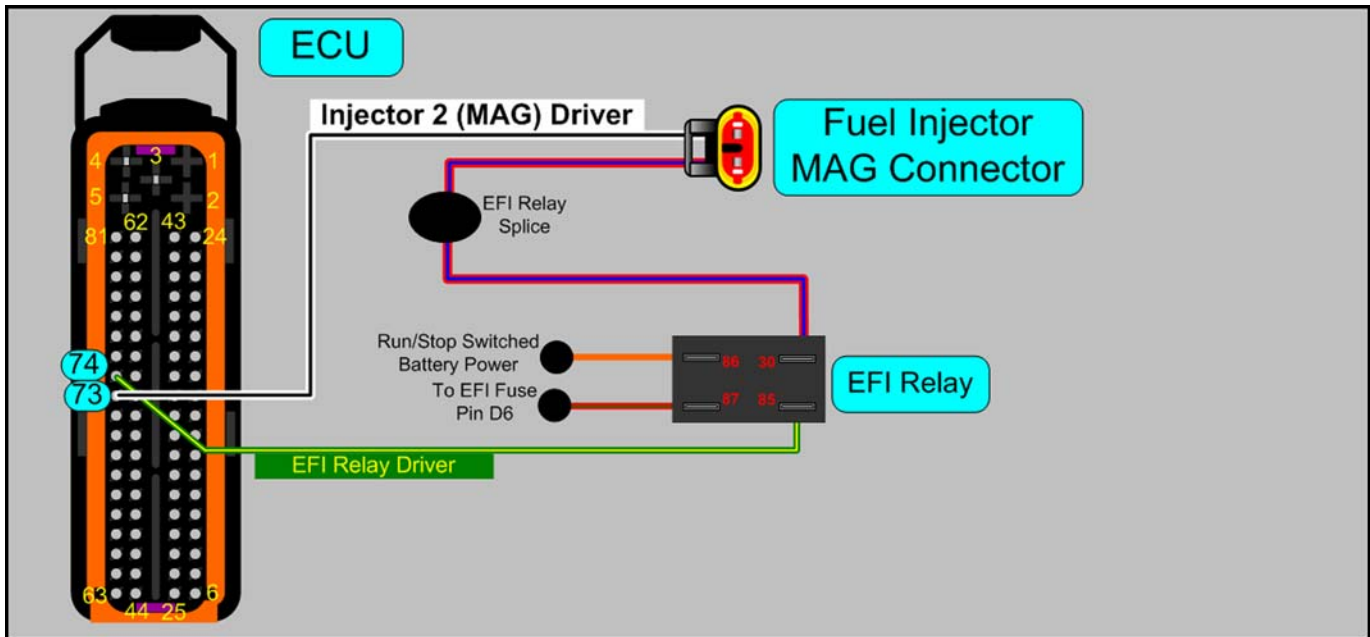

Idle Air Control (IAC) Circuit

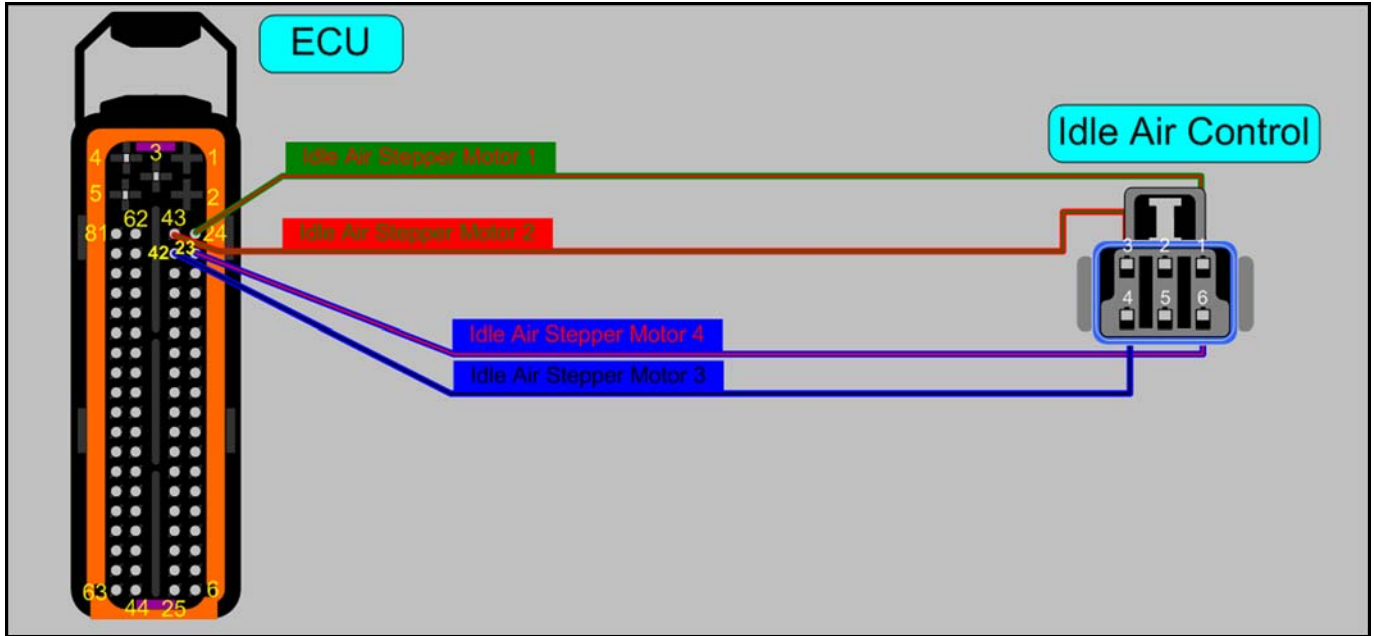

3

Crankshaft Position Sensor (CPS) Circuit

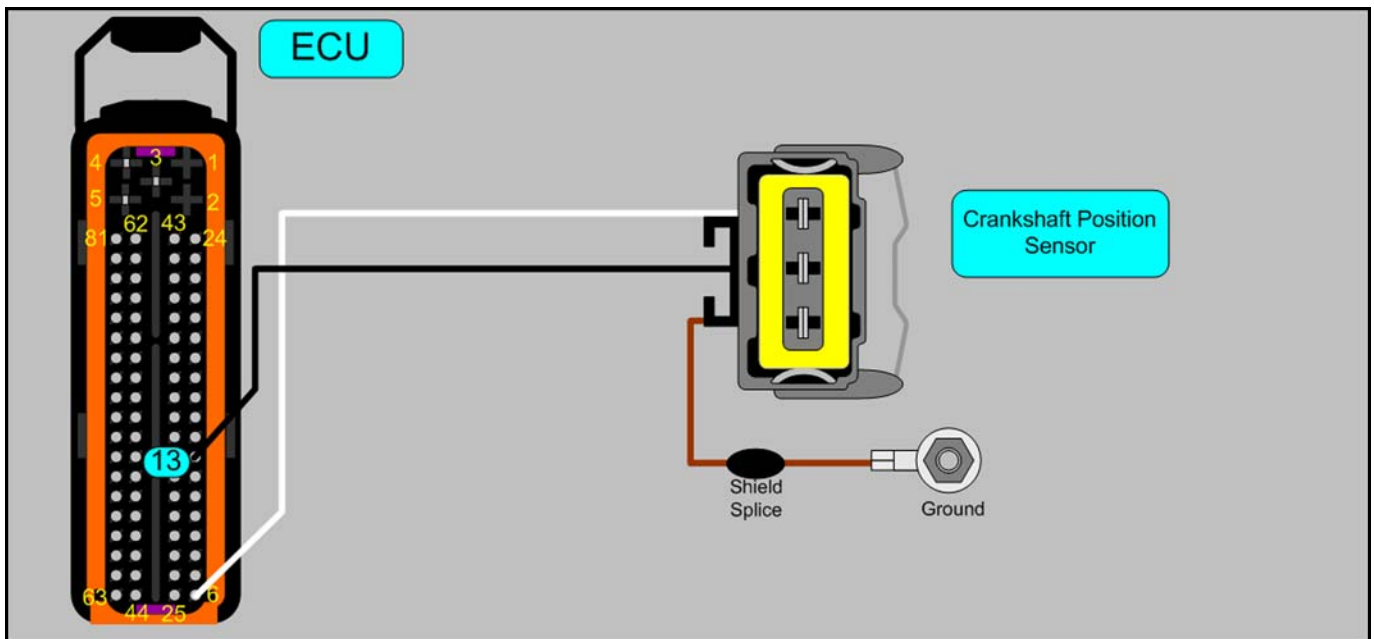

ELECTRONIC FUEL INJECTION

Fuel Pump / Fuel Level Sensor Circuit

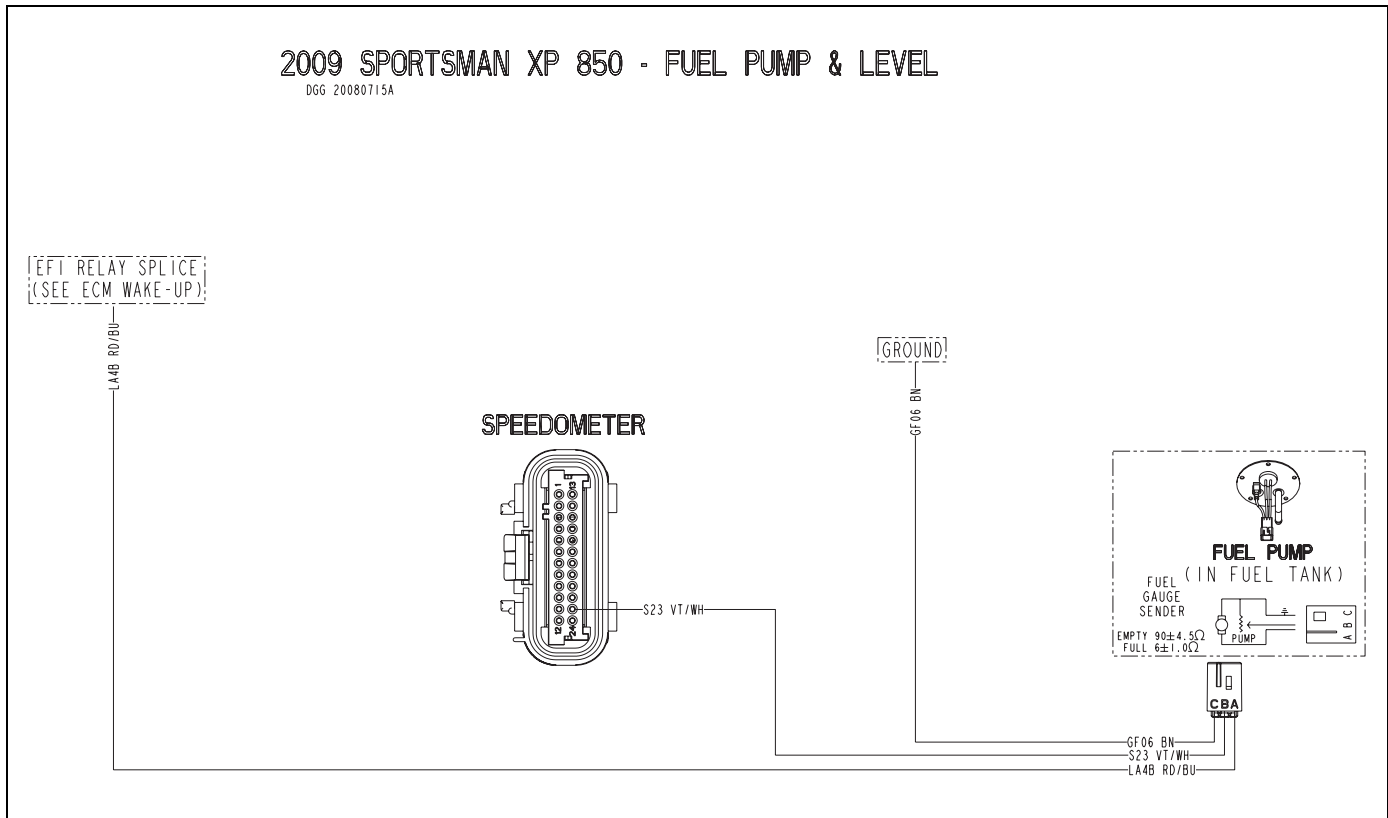

Wire Color Functions

Wire Color	Function
BROWN	Ground
VT / WHT	Fuel Level Sender Signal
RED / BLUE	EFI Relay Output Battery Voltage

Fuel Pump Circuit

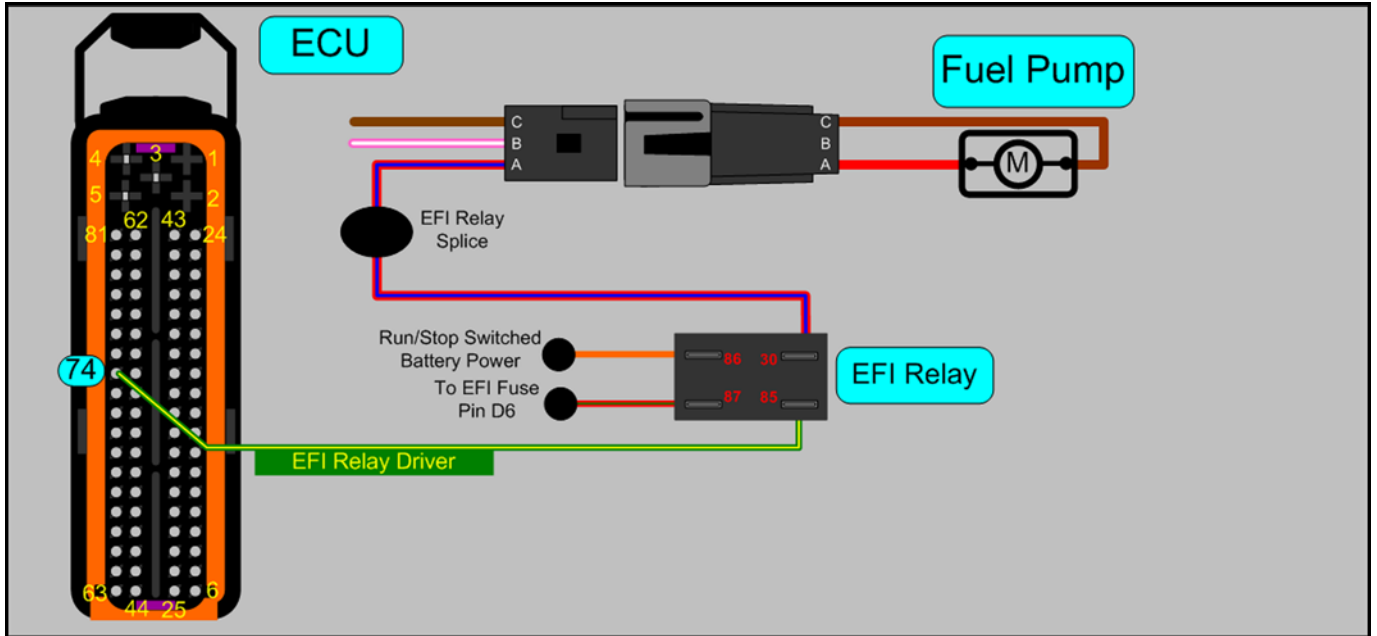

3

Fuel Gauge Circuit

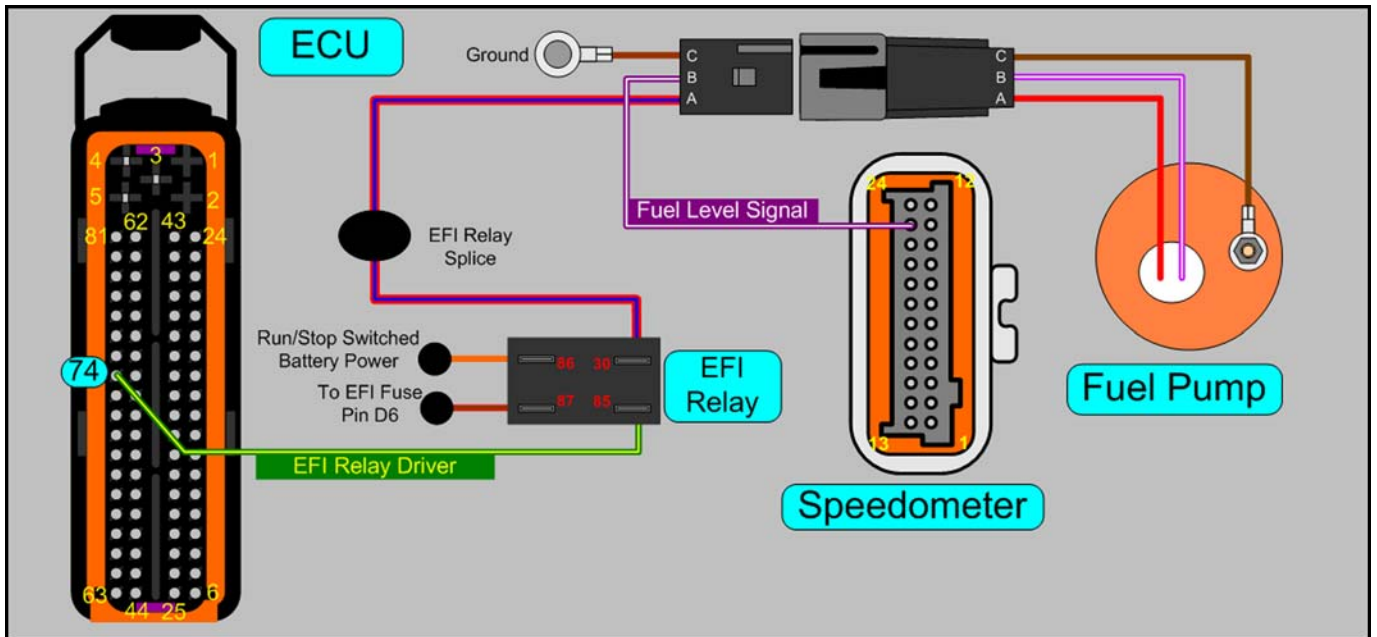

ELECTRONIC FUEL INJECTION

Engine Coolant Temperature Sensor (ECT) Circuit

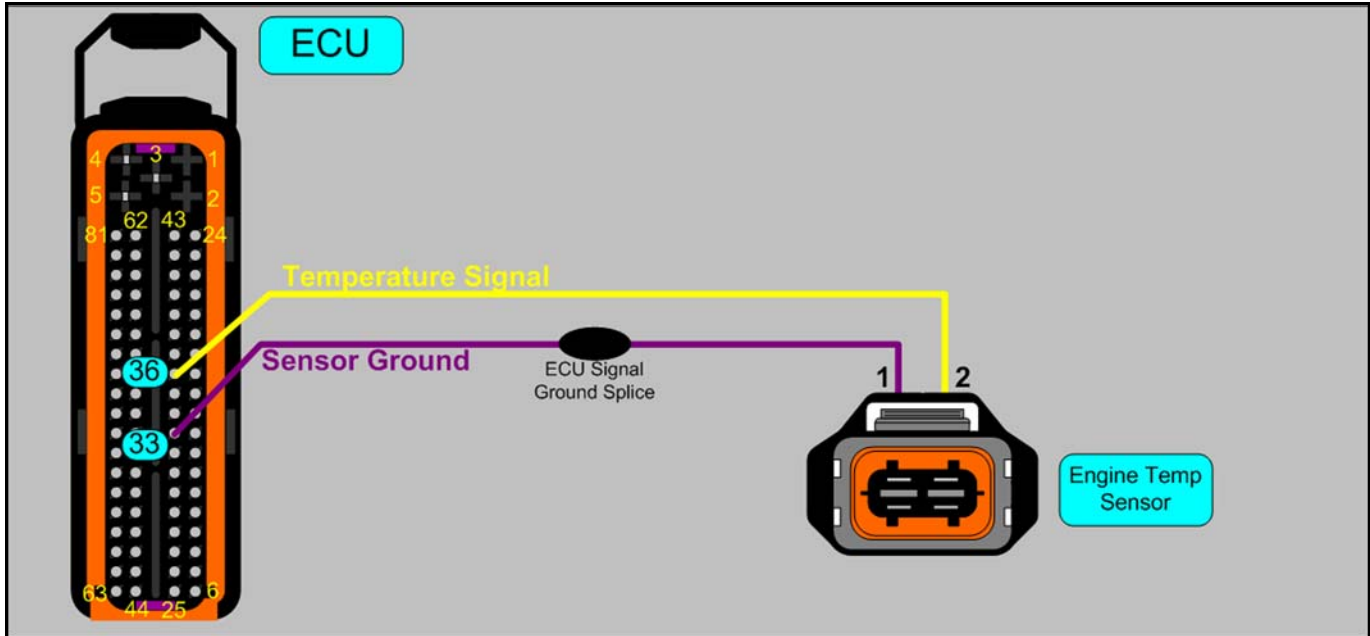

Throttle Position Sensor (TPS) Circuit

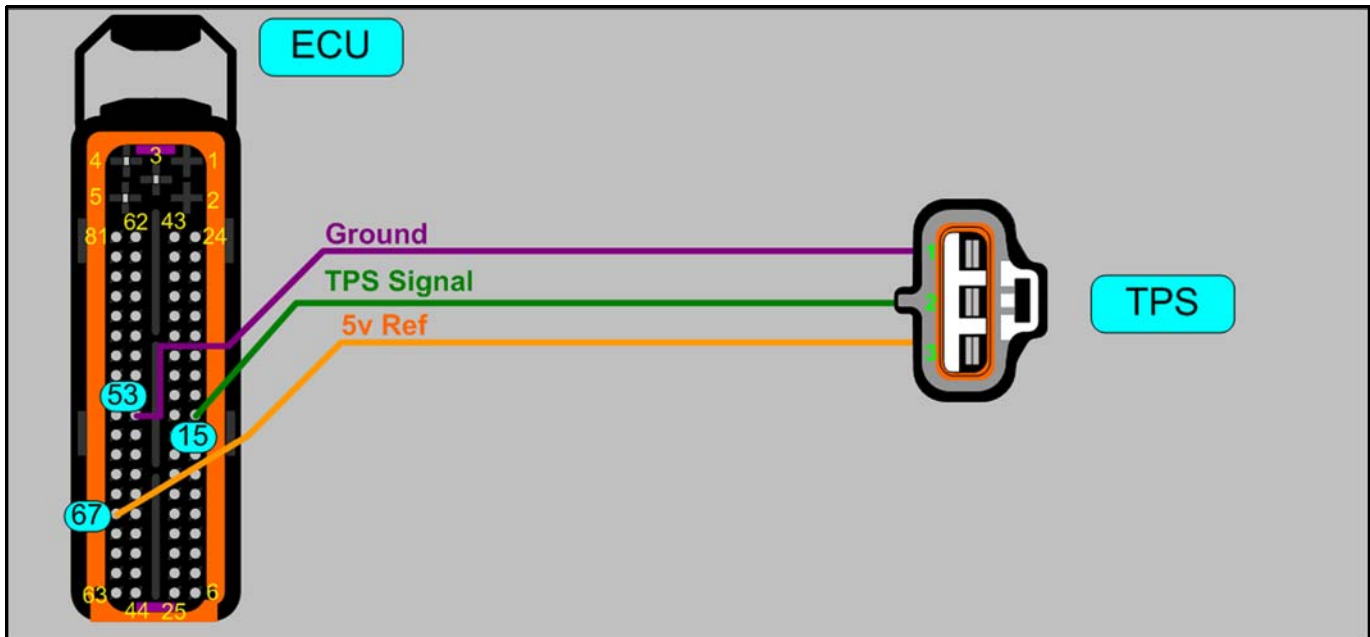

Intake Air Temperature / Manifold Absolute Pressure Sensor (T-MAP) Circuit

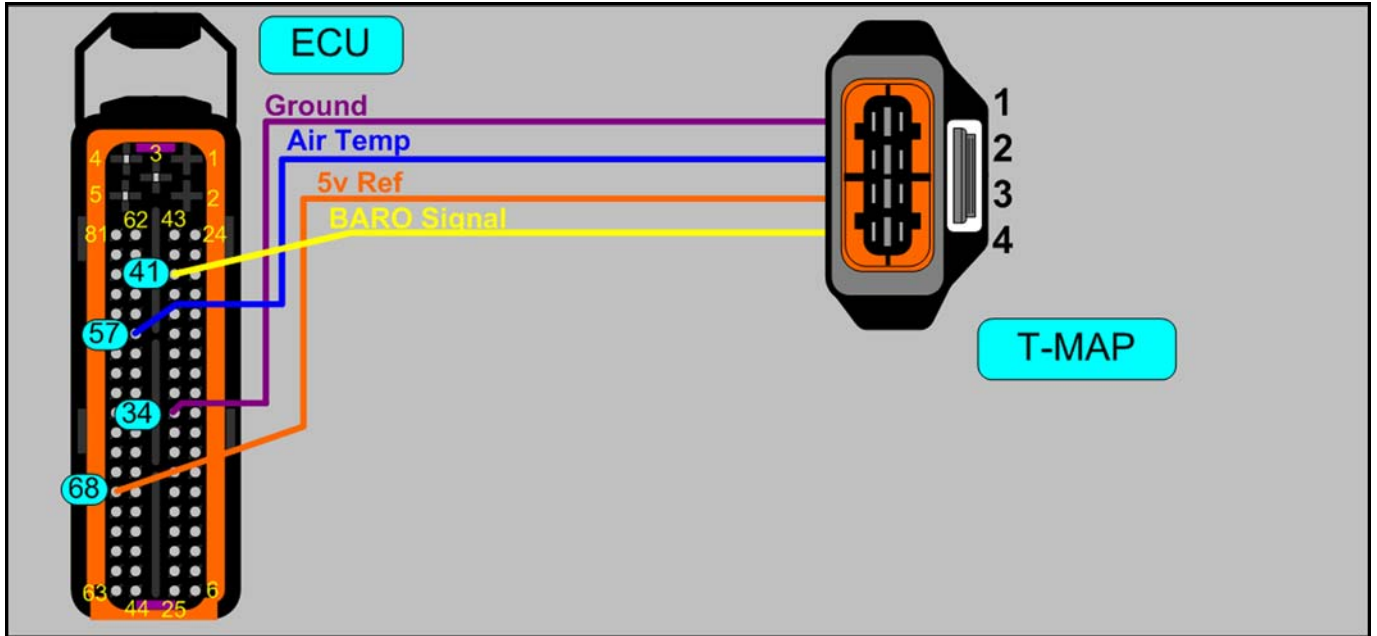

3

Diagnostic Connector Circuit

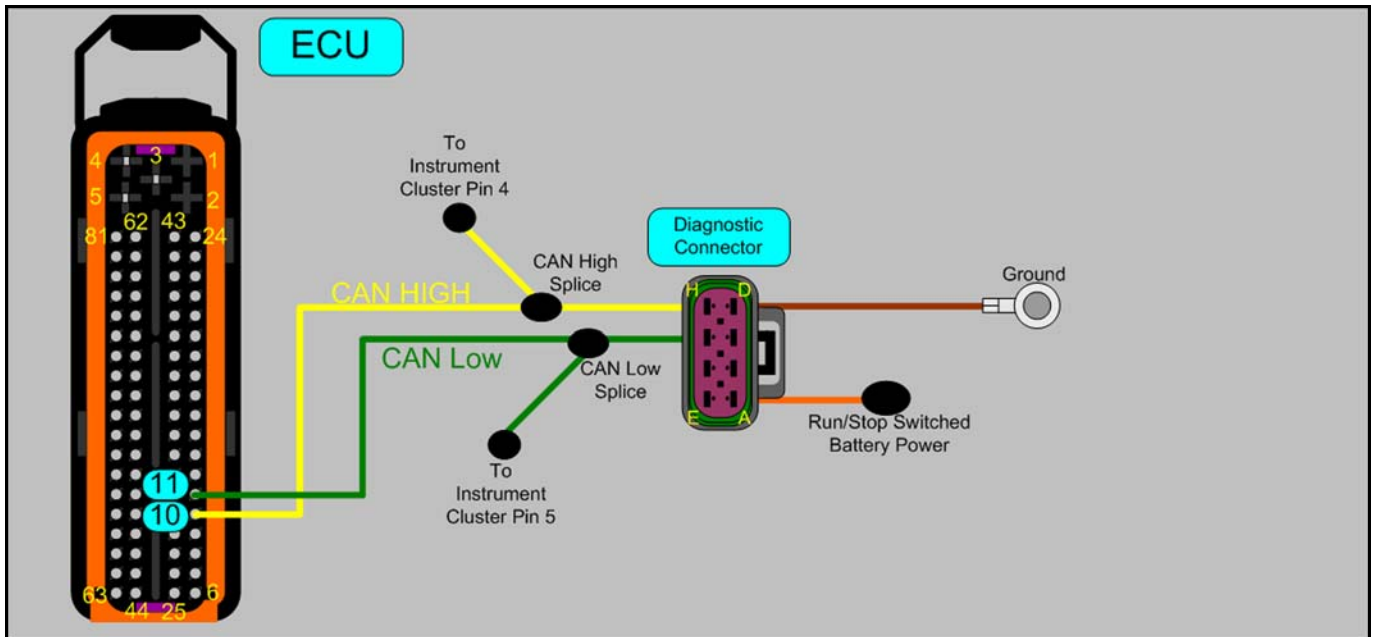

ELECTRONIC FUEL INJECTION

Diagnostic Connector Circuit (EPS Models)

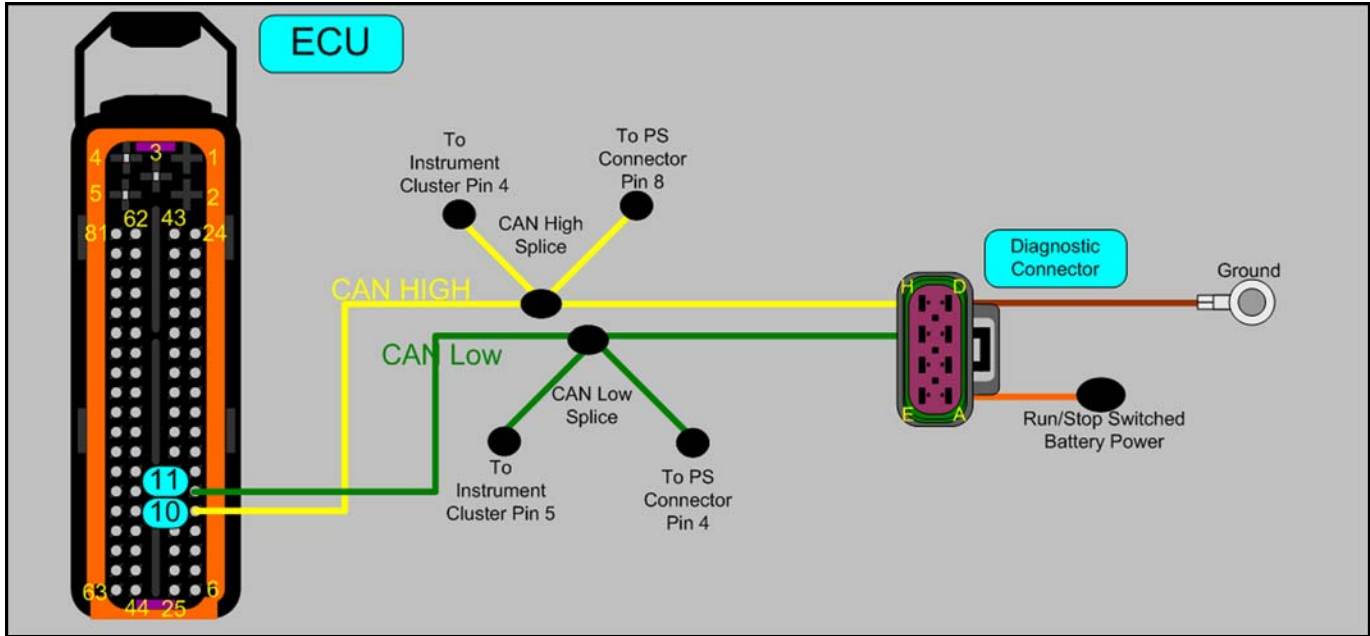

CHAPTER 4

COOLING SYSTEM

SPECIAL TOOLS 4.2

TORQUE SPECIFICATIONS..... 4.2

COOLING SYSTEM..... 4.2

 COOLING SYSTEM LAYOUT AND TESTING..... 4.2

 COOLING SYSTEM SPECIFICATIONS..... 4.3

 COOLING SYSTEM BLEEDING PROCEDURE 4.4

RADIATOR 4.4

 RADIATOR CLEANING 4.4

 COOLANT DRAIN / RADIATOR REMOVAL 4.4

WATER PUMP SERVICE 4.6

 WATER PUMP IMPELLER REMOVAL 4.6

 WATER PUMP MECHANICAL SEAL REPLACEMENT..... 4.7

 WATER PUMP SHAFT & BEARING REPLACEMENT 4.8

 STATOR COVER INSTALLATION..... 4.9

 WATER PUMP ASSEMBLY / TORQUE SPECIFICATIONS 4.10

 STATOR COVER ASSEMBLY TORQUE SPECIFICATIONS 4.11

THERMOSTAT 4.12

 REMOVAL / INSTALLATION 4.12

TROUBLESHOOTING..... 4.12



sales@midwestmanuals.com

www.midwestmanuals.com

COOLING SYSTEM

SPECIAL TOOLS

PART NUMBER	TOOL DESCRIPTION
2870975	Mity Vac™ Pressure Test Tool
PA-44995-A	Water Pump Mechanical Seal Installer
PA-49378	Water Pump Bearing and Coupler Press Tool
PA-49316	Water Pump Drive Nut / Flywheel Puller

TORQUE SPECIFICATIONS

TORQUE SPECIFICATIONS		
Fastener	Size	EH085OLE Torque
Thermostat Housing	6 mm	89 in. lbs. (10 Nm)
Water Pump Impeller Bolt	6 mm	10 ft. lbs. (13.5 Nm)
Water Pump Cover	6 mm	89 in. lbs. (10 Nm)
Engine Temperature Sensor (ECT)	3/8 NPT	17 ft. lbs. (23 Nm)
Stator / Magneto Cover Bolts	6 mm	89 in. lbs. (10 Nm)

COOLING SYSTEM

Cooling System Layout and Testing

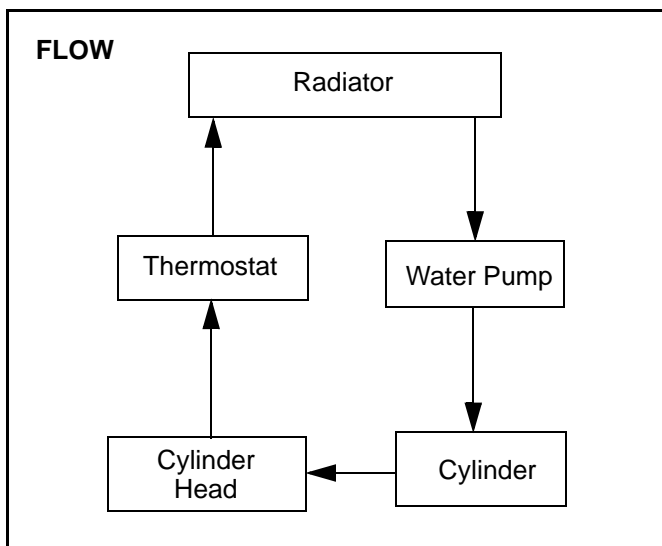

Cooling System Pressure Test

1. Remove the front rack (see Chapter 9 “Front Rack”).

⚠ WARNING

Never remove radiator cap when engine is warm or hot. The cooling system is under pressure and serious burns may result. Allow the engine and cooling system to cool before servicing.

2. Remove the pressure cap from the radiator and pressure test the cooling system using a commercially available tester.
3. The system must retain 10 psi for five minutes or longer. If pressure loss is evident within five minutes, check the radiator, all cooling system hoses, hose clamps and water pump seal for leakage.

Radiator Cap Pressure Test

⚠ WARNING

Never remove radiator cap when engine is warm or hot. The cooling system is under pressure and serious burns may result. Allow the engine and cooling system to cool before servicing.

1. Remove radiator pressure cap and test using a cap tester (commercially available).
2. The radiator cap relief pressure is 13 lbs. Replace cap if it does not meet this specification.

Recommended Coolant

Use only high quality antifreeze/coolant mixed with distilled water in a 50/50 or 60/40 ratio, depending on freeze protection required in your area.

IMPORTANT: Using tap water in the cooling system will lead to a buildup of deposits which may restrict coolant flow and reduce heat dissipation, resulting in possible engine damage. Polaris Premium 60/40 Antifreeze/Coolant is recommended for use in all cooling systems, and comes pre-mixed and ready to use.

Polaris Premium Antifreeze
2871534 - Quart
2871323 - Gallon

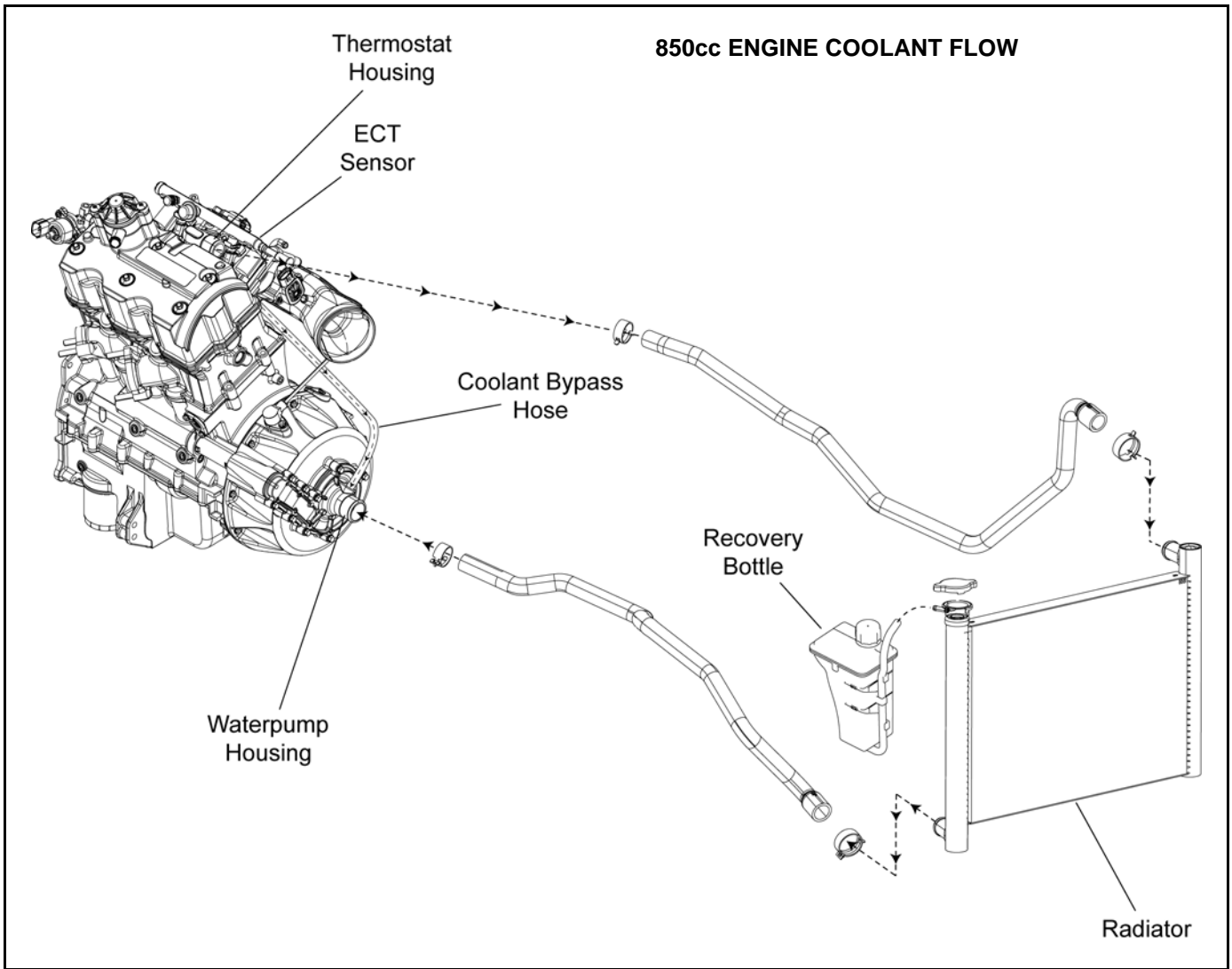

Cooling System Specifications

The engine coolant temperature sensor is located in the engine cylinder head below the thermostat housing (see Chapter 3 for further information).

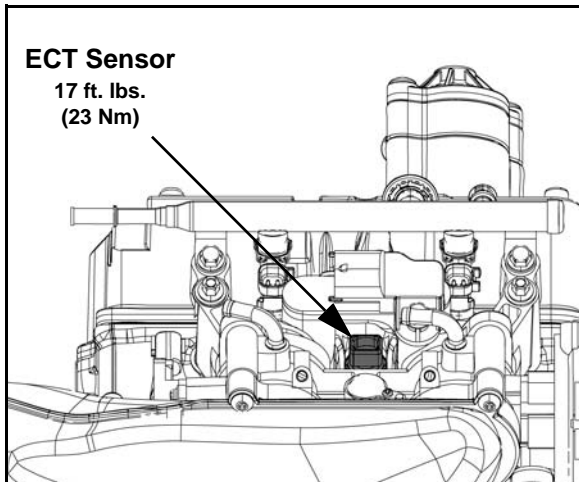

Resistance Reading @ Idle

Condition	Approx. Reading (Ohms)	Temperature
Engine Shut Off	70 Ω ± 3%	284° F (140° C)
Hot Lamp On (engine misfire above idle)	90 Ω ± 3%	266° F (130° C)
Hot Lamp Blinking	100 Ω ± 3%	257° F (125° C)
Fan On	215 Ω ± 3%	203° F (95° C)
Fan Off	240 Ω ± 3%	192° F (89° C)
Room Temperature	2.5k Ω ± 3%	68° F (20° C)
System Capacity	2 qts. (1.9 l)	
Radiator Cap Relief Pressure	13 PSI	

COOLING SYSTEM

Cooling System Bleeding Procedure

1. Place the vehicle in PARK.

CAUTION

Be sure the engine has cooled and there is no pressure built up in the cooling system before removing the radiator cap. The coolant may be hot and could cause severe injury or burns.

2. Remove the front rack to access the radiator pressure cap and recovery bottle.
3. Remove the pressure cap and top off coolant. Leave the pressure cap off at this point.
4. Remove recovery bottle fill cap and fill the bottle to the "MAX" line. Reinstall the recovery bottle cap.

NOTE: If the coolant level is LOW in the radiator, or if there are leaks in the system, the coolant system will not draw coolant from the recovery bottle.

5. Start the engine and allow it to idle for 5-10 minutes until the thermostat opens and allows coolant to travel through the entire system.

NOTE: When the thermostat opens the radiator coolant level will drop significantly.

6. Squeeze the coolant lines to help purge the system of air.
7. With the engine still idling, top off the radiator with Polaris Premium Antifreeze. If no air bubbles are seen at the radiator filler neck, the system should be purged of air.
8. Reinstall the radiator pressure cap

WARNING

Be sure to install the radiator pressure cap before shutting off the engine. Coolant may spit out of the radiator.

9. Stop the engine and allow it to cool. Top off the radiator with coolant. If you hear or see a "glug" at the filler neck or the coolant level drops indicating that coolant has been pulled into the system, fill the radiator first before filling the recovery bottle.
10. Any air remaining in the system should continue to bleed out through the recovery bottle
11. Repeat this procedure if you are still having difficulty bleeding the system.

RADIATOR

Radiator Cleaning

1. Check radiator air passages for restrictions or damage.

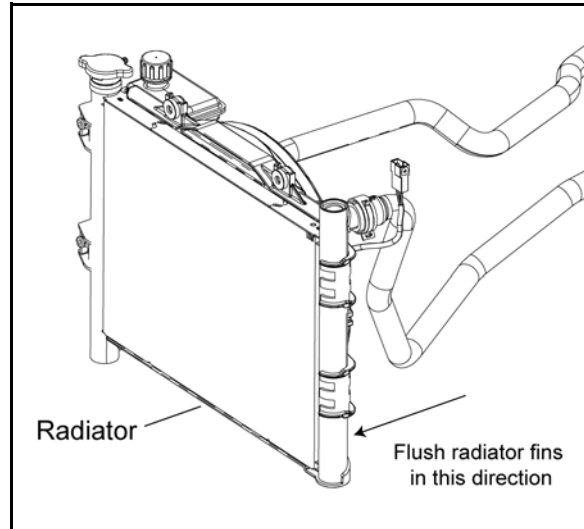

2. Carefully straighten any bent radiator fins.
3. Remove any obstructions with compressed air or low pressure water.

CAUTION

Washing the vehicle with a high-pressure washer could damage the radiator fins and impair the radiators effectiveness. Use of a high-pressure washer is not recommended.

Coolant Drain / Radiator Removal

Coolant Drain

1. Remove the front rack to access the pressure cap (see Chapter 9 "Front Rack").

WARNING

Never drain the coolant when the engine and radiator are warm or hot. Hot coolant can cause severe burns. Allow engine and radiator to cool.

2. Slowly remove the pressure cap to relieve any cooling system pressure.
3. Place a suitable drain pan underneath the radiator on the right-hand side of the vehicle.

4. Drain the coolant from the radiator by removing the coolant hose from the lower right-hand portion of the radiator.



5. Completely drain the coolant and properly dispose of it.

Radiator Removal

1. Drain coolant from the radiator (see previous procedure).
2. Remove the front rack (see Chapter 9 "Front Rack").
3. Remove the hose from the left-hand portion of the radiator.



4. Remove the recovery bottle return line from the radiator.

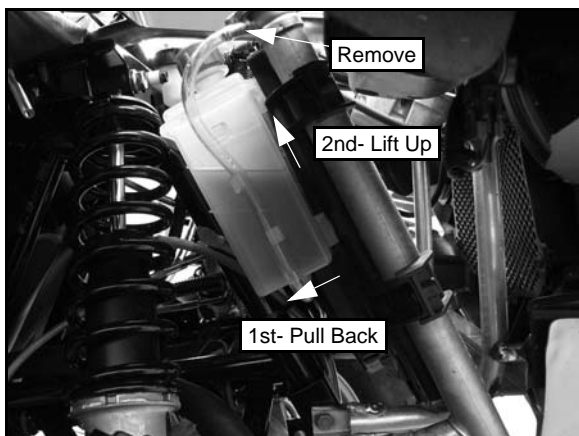

5. Carefully pull rearward on the lower portion of the recovery bottle to disengage the lower tab. Then lift up on the bottle and remove it from the radiator fan shroud.
6. Remove the (2) screws retaining the fuse/relay box to the frame to allow enough room for the radiator to tilt back during removal.



7. Remove the (2) fasteners retaining the upper portion of the radiator to the frame.



8. Disconnect the fan motor.
9. Tilt the radiator back and lift upward to allow the lower grommets to clear the frame support holes. Remove the radiator from the vehicle out the right-hand side through the wheel well. Take care not to damage the cooling fins during removal.
10. Reverse procedure for installation. When installing the recovery bottle, insert the upper portion of the bottle into the shroud first, then push the lower tab on the bottle into the shroud until it snaps into place.
11. After installation and reassembly, remove the pressure cap and fill the radiator and recovery bottle with coolant.
12. Refer to the "Cooling System Bleeding Procedure" in this chapter.

COOLING SYSTEM

WATER PUMP SERVICE

Water Pump Impeller Removal

NOTE: The water pump impeller, mechanical seal, drive coupler, pump shaft, and pump shaft bearing can be serviced without removing the engine.

1. Remove the fuel tank (see Chapter 3).
2. Remove the (4) screws retaining the engine skid plate and remove the plate from the vehicle.
3. Place a drain pan under the front portion of the engine.
4. Slide the spring clamp back and remove the coolant inlet hose from the water pump housing.

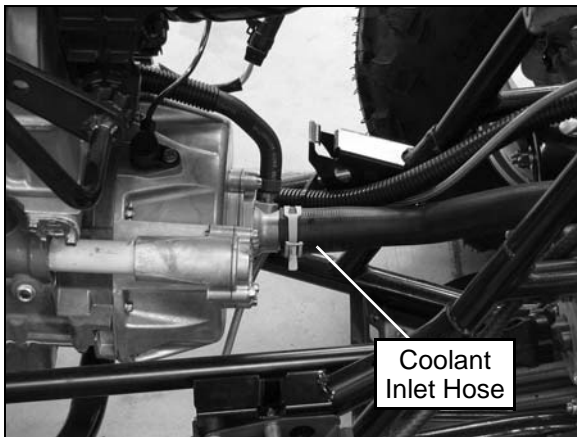

5. Slowly drain the coolant into the drain pan. Dispose of used coolant properly.



6. Remove the coolant by-pass hose from the water pump cover fitting.

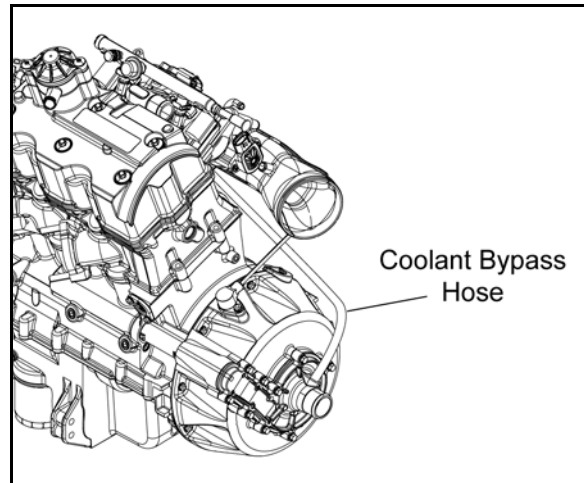

7. Remove the (10) cover screws (A) and pump cover (B).

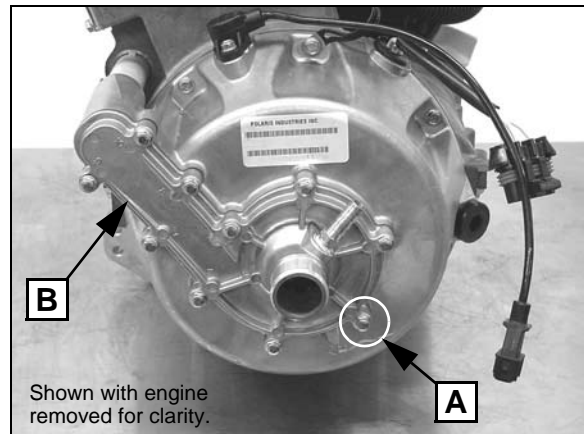

8. Remove gasket, impeller bolt, washer, and impeller.

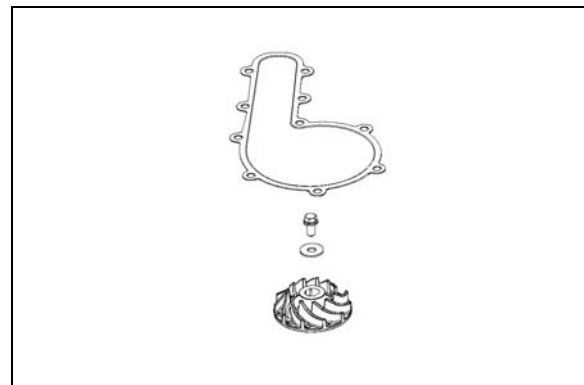

Water Pump Mechanical Seal Replacement

Perform the “Water Pump Impeller Removal” procedure.

1. Disconnect the stator and CPS wire harnesses.

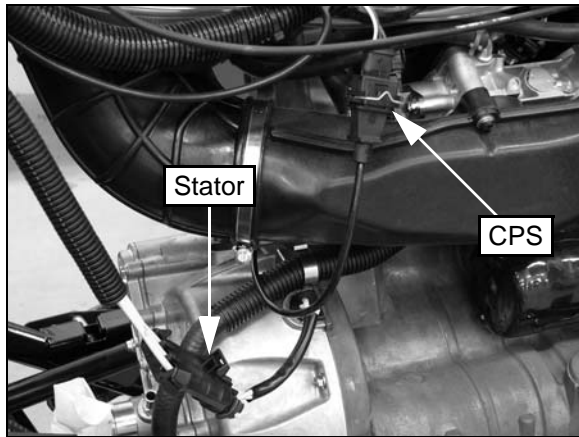

2. Remove the (8) stator cover screws.
3. Carefully remove the stator cover taking care not to damage the plastic coolant pipe.

⚠ CAUTION

The flywheel contains powerful magnets. Use caution when removing the stator cover. DO NOT place fingers between cover and crankcase at any time during the removal process or injury could result.

4. Remove the CPS, stator wire guide, and stator from the cover.

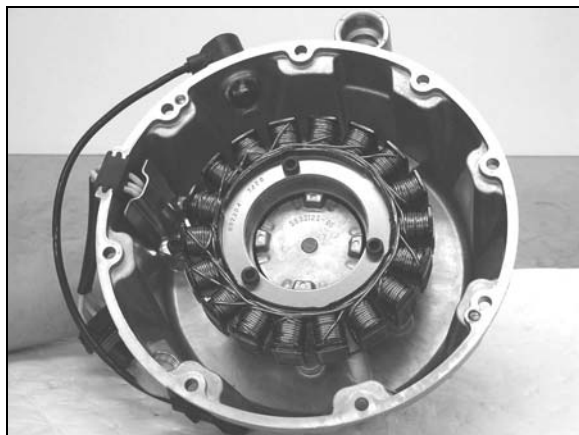

5. Support the stator cover by the *stator mounting boss*, using an aluminum or PVC pipe section or other suitable support block (C) positioned inside the stator housing as shown. **Do not attempt to press water pump shaft out of stator housing without first supporting the cover by the stator boss, or cover may be damaged.**

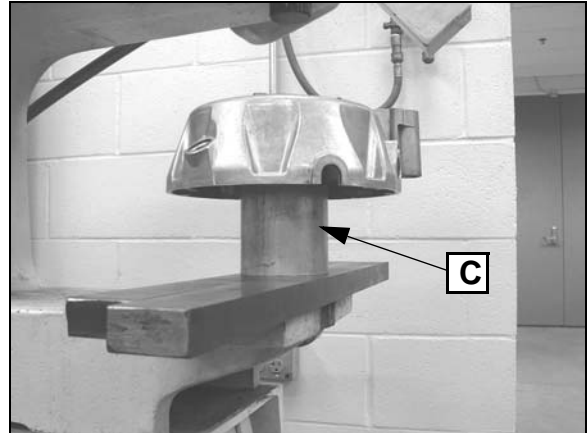

6. Press shaft down until flush with end of mechanical seal or until the seal spring starts to compress.

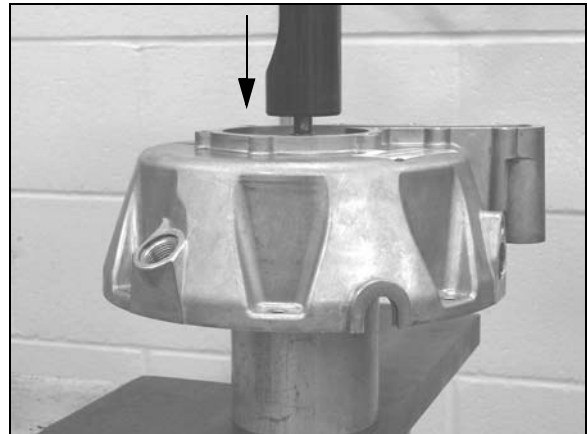

7. Select a suitable arbor (D) and press the shaft through the seal until the shaft assembly is removed.



COOLING SYSTEM

Water Pump Mechanical Seal Replacement (Cont.)

- Protect water pump cover gasket surface and turn cover over. Drive mechanical seal out from stator side of cover.



- Clean housing thoroughly.

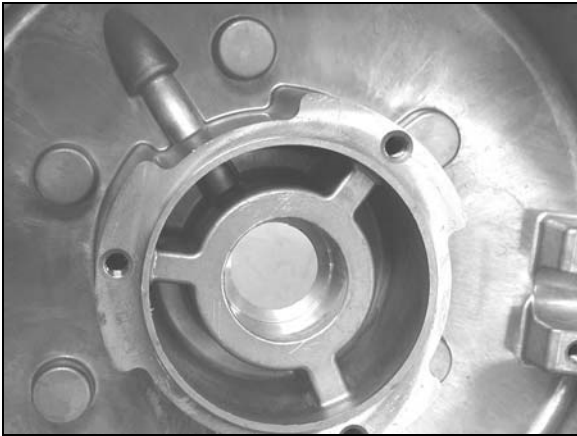

If pump shaft assembly (shaft, drive coupler hub, and bearing) is in good condition, proceed to the next step. If any of these parts require replacement, refer to the "Water Pump Coupler Shaft & Bearing Replacement" procedure.

- Press pump shaft / bearing assembly into housing until firmly seated.



- Turn cover over and drive new mechanical seal squarely into housing using seal installer.

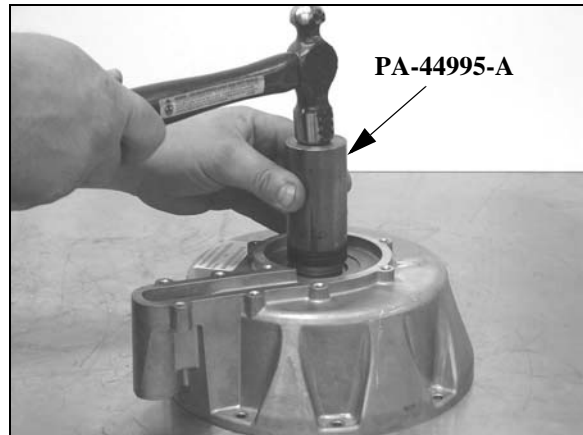

- Install impeller. Torque bolt to 10 lb-ft. (13.5 Nm)
- Rotate impeller and check for smooth rotation.

Water Pump Shaft & Bearing Replacement

- Press new shaft / bearing assembly from kit into cover from stator side as shown, using the recessed end of Bearing and Coupler Press Tool PA-49378.

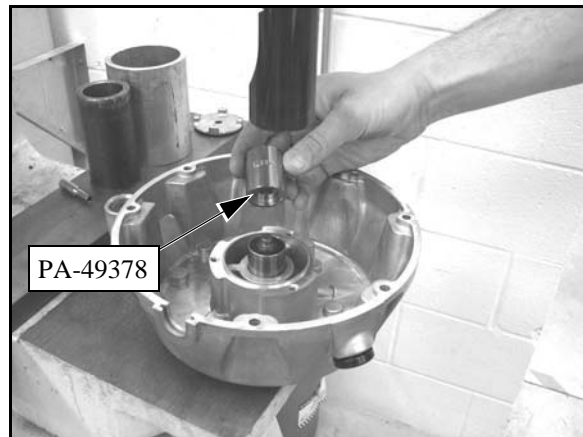

- Press until bearing is fully seated in cover.



⚠ CAUTION

Be sure bearing is fully seated in cover after Step 2, or severe crankshaft damage will result.

3. Install new coupler hub (A) from kit onto shaft.

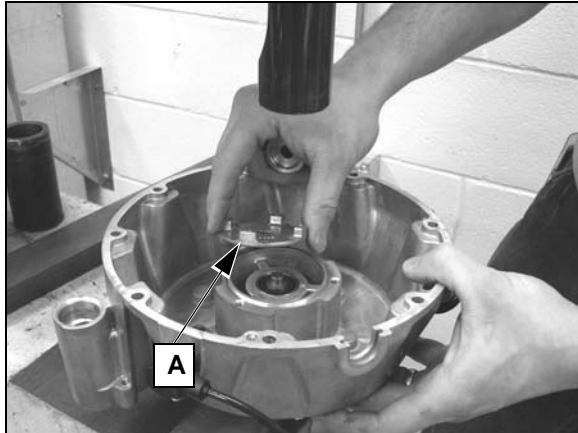

4. Press coupler squarely onto shaft until fully seated.

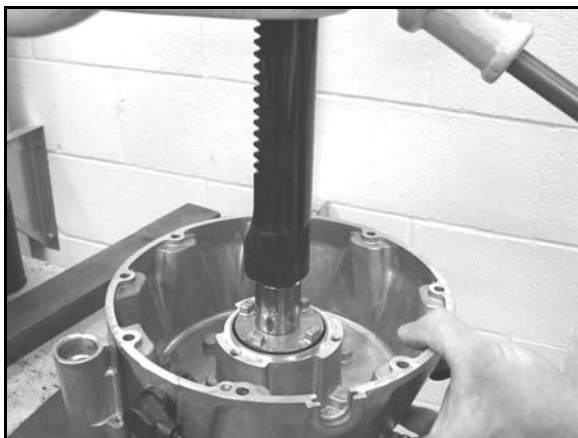

5. Turn cover over and drive new mechanical seal squarely into housing using seal installer.

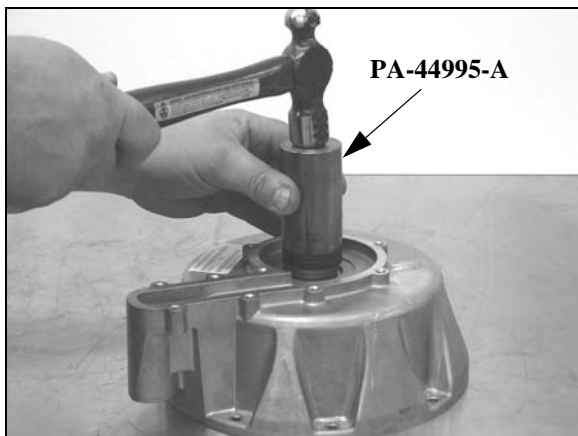

6. Install impeller. Torque bolt to 10 lb-ft. (13.5 Nm).

7. Rotate impeller and check for smooth rotation.
8. Refer to the following pages for water pump assembly and torque information.

Stator Cover Installation

1. Orientate the pump shaft tab to line up with the stator mounting bolt closest to the CPS sensor.



2. Rotate flywheel so coupler nut slot is in the 12:00 position.

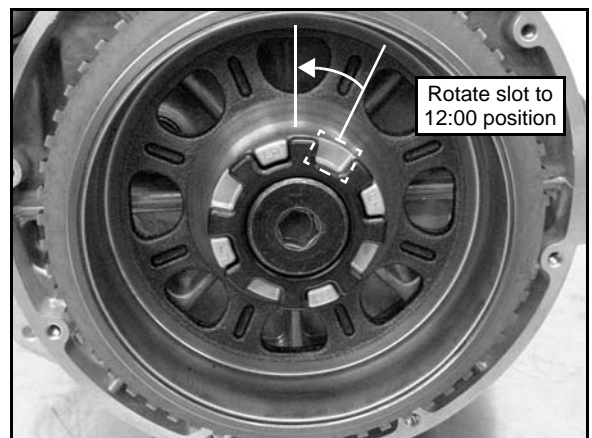

3. Install new O-rings on the plastic coolant pipe. Lubricate the O-rings with P80 (rubber lubricant) or lithium grease.

⚠ CAUTION

The flywheel contains powerful magnets. Use caution when installing the stator cover. DO NOT place fingers between cover and crankcase at any time during the installation process or injury could result.

4. Carefully install the stator cover.
5. Check the water pump coupler engagement by turning the impeller bolt with a ratchet and 10 mm deep-well socket.
6. Refer to the following pages for stator cover assembly and torque information.

COOLING SYSTEM

Water Pump Assembly / Torque Specifications

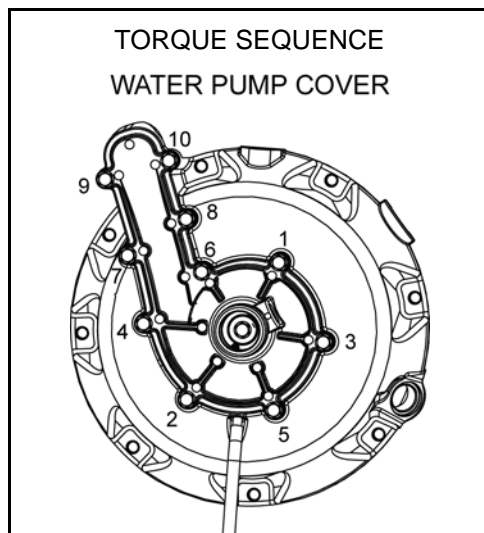
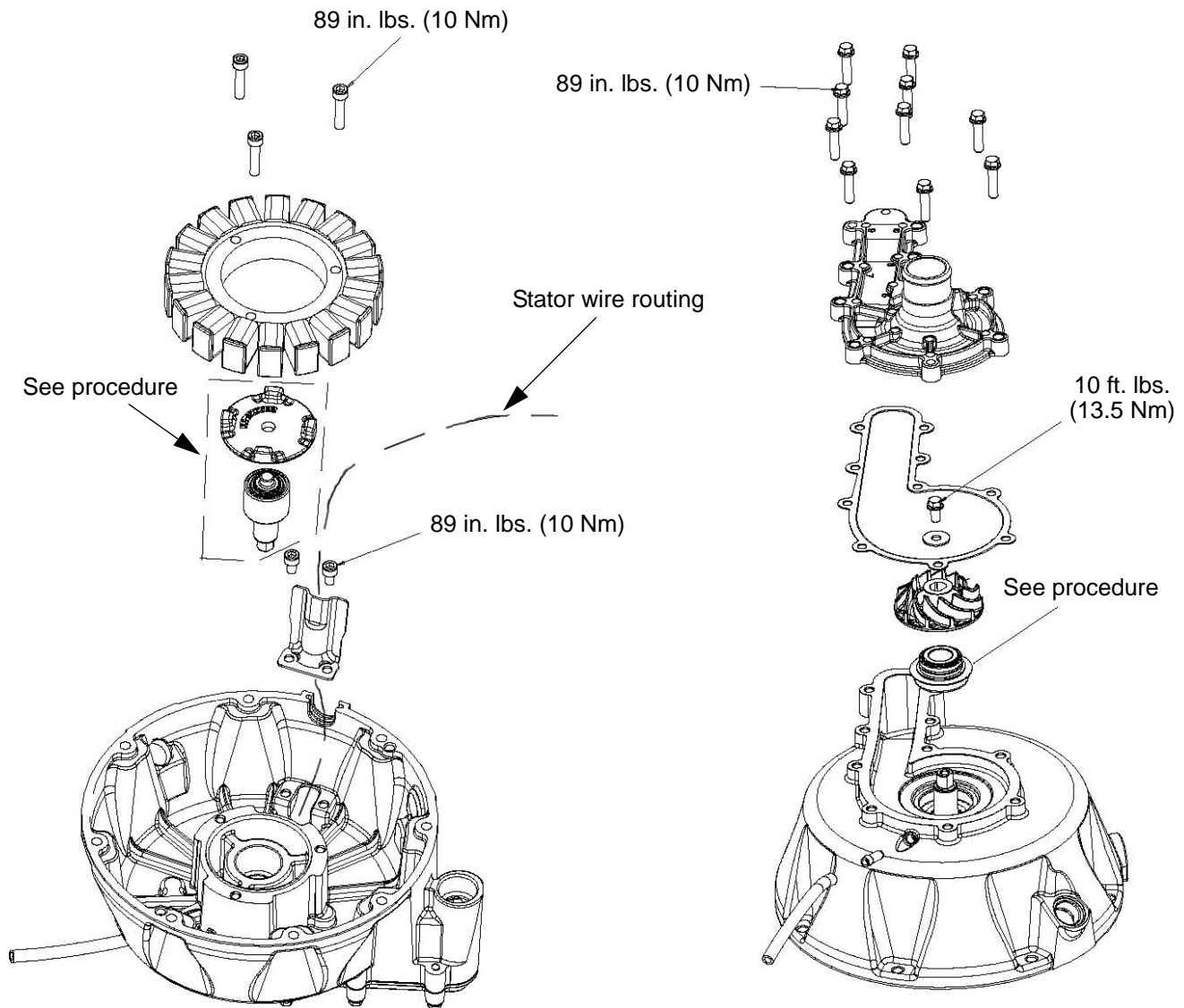

Stator Cover Assembly Torque Specifications

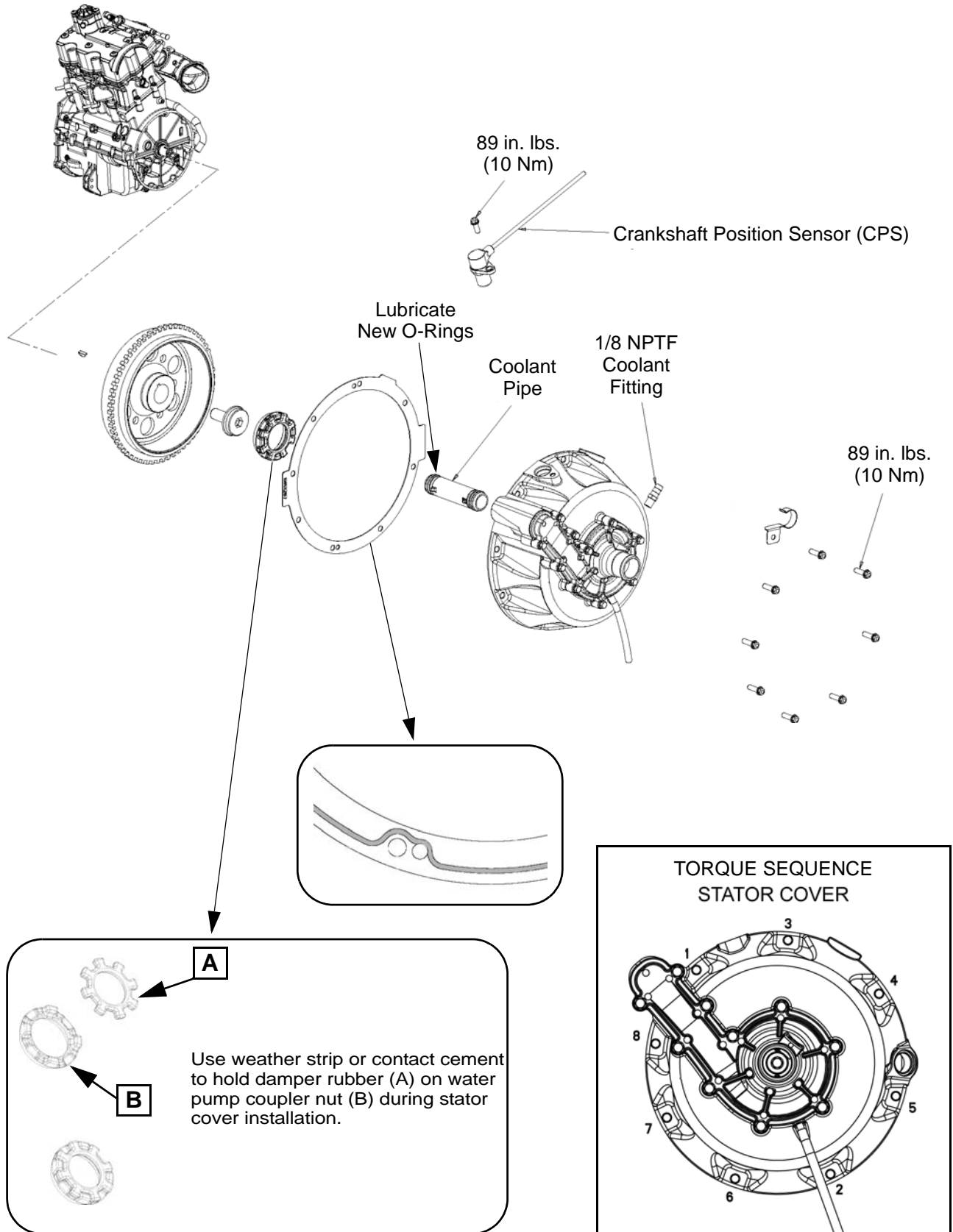

COOLING SYSTEM

THERMOSTAT

Removal (Engine Installed)

1. Drain coolant so the coolant level is below the thermostat housing (see "Coolant Drain / Radiator Removal").
2. Remove the (2) screws from the rear portion of the air box.
3. Locate the thermostat housing on the left side of the valve cover next to the fuel rail.

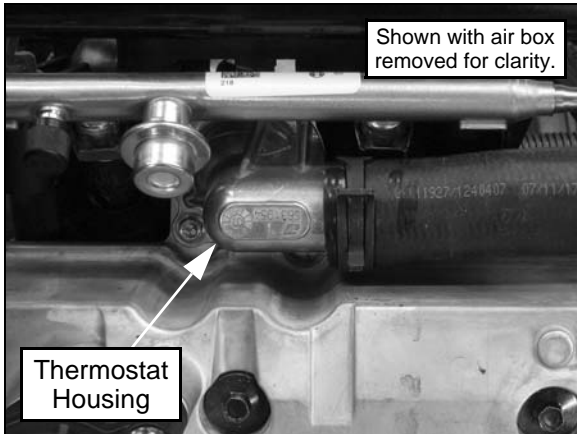

4. Remove the (2) screws and lift the housing up far enough to remove the thermostat with the coolant line still attached.

Installation

1. Install the thermostat, thermostat cover, and the (2) screws. Torque screws to specification.

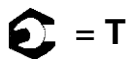
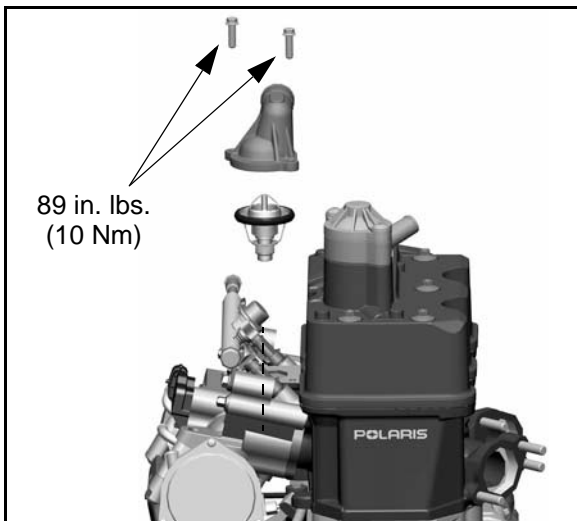

Thermostat Housing Screws:
89 in. lbs. (10 Nm)

2. If servicing while the engine is in the vehicle, perform the "Cooling System Bleeding Procedure".

TROUBLESHOOTING

Cooling System

Overheating

- Low coolant level
- Air in cooling system
- Wrong type/mix of coolant
- Faulty pressure cap or system leaks
- Restricted system (mud or debris in radiator fins causing restriction to air flow, passages blocked in radiator, lines, pump, or water jacket, accident damage)
- Lean mixture (fuel system restriction)
- Fuel pump output weak
- Electrical malfunction
- Water pump failure/ Loose impeller
- Engine Coolant Temperature Sensor failure
- Cooling fan inoperative or turning too slowly (perform current draw test)
- Low oil level
- Spark plug incorrect heat range
- Faulty hot lamp circuit
- Thermostat stuck closed or not opening completely

Temperature Too Low

- Thermostat stuck open

Leak at Water Pump Weep Hole

- Faulty water pump mechanical seal
- Worn pump shaft or pump shaft bearing

CHAPTER 5

ENGINE

GENERAL INFORMATION - ENGINE	5.3
SPECIAL TOOLS	5.3
ENGINE LUBRICATION SPECIFICATIONS	5.3
OIL PRESSURE TEST	5.3
OIL FLOW DIAGRAM	5.4
ENGINE SPECIFICATIONS - EH085OLE-011	5.5
ENGINE ASSEMBLY VIEWS AND TORQUE VALUES	5.7
TORQUE & TORQUE SEQUENCE - MAIN ENGINE COMPONENTS	5.7
VALVE COVER / BREATHER VALVE	5.8
CAMSHAFT CARRIER / CAMSHAFT / ROCKER ARM	5.9
CYLINDER HEAD / VALVE / IAFM	5.10
VALVE & SPRING HEIGHT DETAIL	5.11
PISTON / CONNECTING ROD	5.12
CRANKSHAFT	5.13
CRANKCASE	5.14
CRANKCASE - UPPER	5.15
BALANCE SHAFT / BALANCE SHAFT TIMING	5.16
CRANKCASE (LOWER) WITH OIL PUMP	5.17
WATER PUMP COUPLER	5.18
WATER PUMP / WATER PUMP COUPLER / STATOR / FLYWHEEL	5.19
DRIVE COUPLER (REAR) / STARTER GEAR	5.20
ENGINE SERVICE	5.21
ACCESSIBLE ENGINE COMPONENTS	5.21
TOP-END SERVICE (ENGINE IN CHASSIS)	5.21
CRANKCASE CYLINDER SERVICE INFORMATION	5.21
ENGINE REMOVAL	5.21
ENGINE INSTALLATION NOTES	5.25
ENGINE DISASSEMBLY AND INSPECTION	5.26
VALVE COVER / BREATHER VALVE	5.26
ROCKER CARRIER / CAMSHAFT REMOVAL	5.26
ROCKER ARM / ROCKER ARM SHAFT INSPECTION	5.27
CAMSHAFT / CAMSHAFT BORE INSPECTION	5.28
CYLINDER HEAD REMOVAL	5.28
CYLINDER HEAD CLEANING	5.28
CYLINDER HEAD WARP INSPECTION	5.29
CYLINDER HEAD DISASSEMBLY	5.29
VALVE INSPECTION	5.30
COMBUSTION CHAMBER	5.31
VALVE GUIDE REMOVAL / INSTALLATION	5.31
VALVE SEAT RECONDITIONING	5.32
CYLINDER HEAD ASSEMBLY	5.34
VALVE SEALING TEST	5.34
CYLINDER HEAD INSTALLATION	5.35
CAMSHAFT / CARRIER ASSEMBLY	5.36
CAMSHAFT / CAMSHAFT CARRIER INSTALLATION	5.36
CAMSHAFT TIMING	5.37
CAM CHAIN TENSIONER INSTALLATION	5.38
CAMSHAFT TIMING - QUICK REFERENCE	5.39
CRANKCASE DISASSEMBLY	5.40
CRANKCASE (LOWER) / OIL PUMP DISASSEMBLY	5.41
CRANKCASE DISASSEMBLY (UPPER)	5.43
PISTON / CONNECTING ROD REMOVAL	5.43
COUNTERBALANCE SHAFT REMOVAL / INSPECTION	5.44
COUNTERBALANCE SPLIT GEAR REPLACEMENT	5.44

ENGINE

CRANKSHAFT / CAM CHAIN REMOVAL	5.46
CAM CHAIN / SPROCKET INSPECTION	5.46
CRANKCASE INSPECTION (LOWER)	5.46
CRANKSHAFT INSPECTION	5.46
CONNECTING ROD INSPECTION	5.47
CONNECTING ROD BIG END BEARING SELECTION	5.48
PISTON / PISTON RING INSPECTION.....	5.48
PISTON RING REMOVAL	5.48
PISTON RING INSTALLED GAP	5.49
PISTON PIN BORE INSPECTION	5.49
CYLINDER INSPECTION.....	5.49
PISTON-TO-CYLINDER CLEARANCE	5.50
HONING - IMPORTANT INFORMATION.....	5.50
ENGINE ASSEMBLY.....	5.51
CRANKCASE PREPARATION - UPPER.....	5.51
PISTON RING INSTALLATION	5.51
PISTON / CONNECTING ROD ASSEMBLY	5.52
PISTON / CONNECTING ROD INSTALLATION	5.52
CRANKSHAFT INSTALLATION.....	5.53
OIL PASSAGE TUBE	5.53
CRANKCASE ASSEMBLY - UPPER	5.54
BALANCE SHAFT INSTALLATION	5.55
BALANCE SHAFT TIMING.....	5.56
CRANKCASE PREPARATION (LOWER)	5.57
CRANKCASE SEALANT AND TORQUE VALUES	5.58
CRANKCASE ASSEMBLY.....	5.59
WATER PUMP	5.59
WATER PUMP IMPELLER REMOVAL	5.59
MECHANICAL SEAL / COUPLER SHAFT & BEARING REPLACEMENT	5.59
TROUBLESHOOTING.....	5.60
ENGINE	5.60



sales@midwestmanuals.com

www.midwestmanuals.com

GENERAL INFORMATION - ENGINE**Special Tools**

Tool Description	Part Number
CRANKSHAFT HOLDING TOOL	PA-49318
CRANKSHAFT SEAL INSTALLER	PA-49320
FLYWHEEL / WATER PUMP DRIVE NUT PULLER	PA-49316
FUEL PRESSURE TEST ADAPTOR	PS-48762
MITY VAC [®] PRESSURE TEST TOOL	2870975
OIL FILTER WRENCH	PV-43527 (2 1/2 in. / 65mm)
PISTON RING COMPRESSOR PLIERS	PV-43570-1
PISTON RING COMPRESSOR BAND - 87mm	PV-43570-3
UNIVERSAL DRIVER HANDLE	PU-45543
VALVE SPRING COMPRESSOR	PV-1253 or PV-4019 (Quick Release)
VALVE SPRING COMPRESSOR ADAPTOR	PV-43513-A
WATER PUMP BEARING AND COUPLER PRESS	PA-49378
WATER PUMP DRIVE NUT / FLYWHEEL PULLER	PA-49316
WATER PUMP MECHANICAL SEAL INSTALLER	PA-44995-A

5

Engine Lubrication Specifications

Capacity - Approximately 2 U.S. Quarts (1.9 l)

Oil Type - Polaris PS4 Plus 2W-50 Synthetic

Filter Wrench - PV-43527 or equivalent

Oil Pressure Specification - 10-25 PSI @ Idle RPM (using Polaris PS4 Plus 2W-50 Synthetic), Engine at operating temperature.

Oil Pressure Test

1. Remove center Main Oil Gallery plug (A) from right side of upper crankcase.
2. Insert a 1/4" NPT oil pressure gauge adaptor and oil pressure gauge.
3. Start engine and allow it to reach operating temperature, monitoring gauge indication.

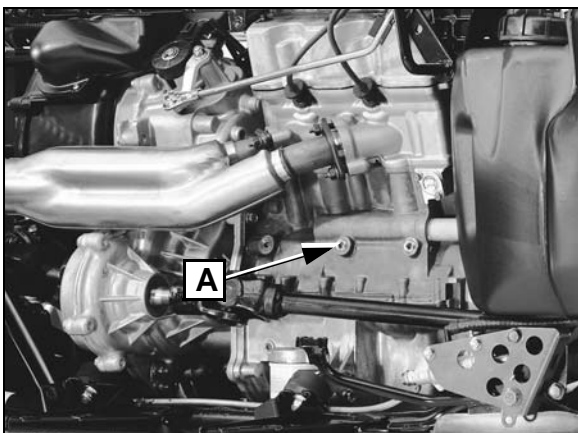

NOTE: Test results are based on the use of the recommended engine oil at operating temperature, and may vary considerably if any other oil is used or if engine is not up to temperature.

Oil Pressure at Idle RPM (Engine Hot):
Standard: 25 PSI
Minimum: 10 PSI

ENGINE

Oil Flow Diagram

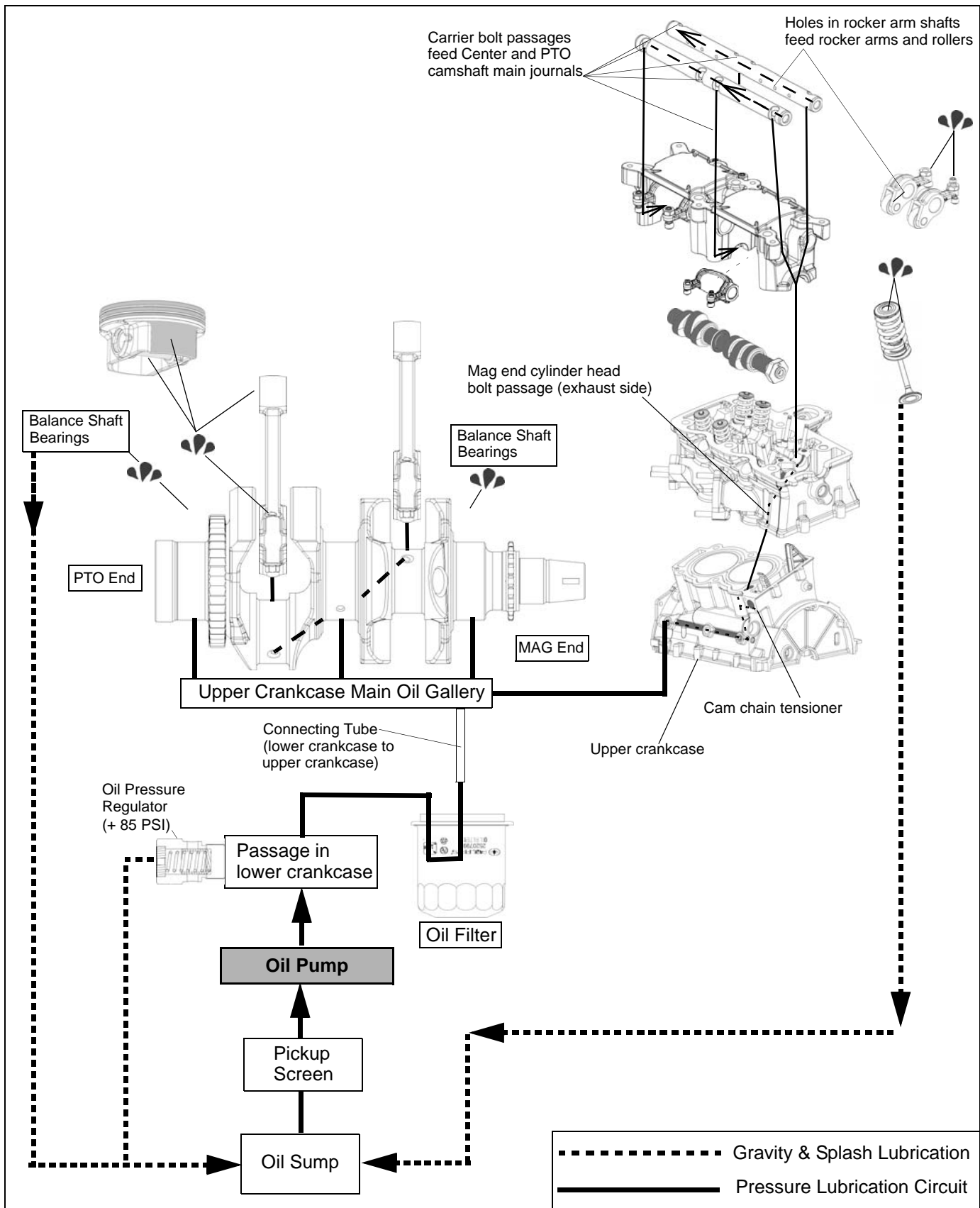

Engine Specifications - EH085OLE-011

CYLINDER HEAD (IN. / MM)		
Camshaft	Cam Lobe Height - Intake (Standard)	0.897" (22.795 mm)
	Cam Lobe Height - Exhaust (Standard)	0.908" (23.067 mm)
	Camshaft Journal Outer Diameter - (All)	.8632" \pm 0.0004" (21.925 \pm 0.01 mm)
	Camshaft Journal Bore Inner Diameter - (All)	.8661" \pm 0.0004" (22.000 \pm 0.01 mm)
	Camshaft Oil Clearance	0.0034" \pm 0.0008" (0.086 \pm 0.02 mm)
	Camshaft End Play	0.008" \pm 0.004" (0.20 \pm 0.10 mm)
Rocker Arm and Shaft	Rocker Shaft O.D. (Intake and Exhaust)	0.5501" (13.973 - 13.984 mm)
	Rocker Arm I.D. (Intake and Exhaust)	0.5514" - 0.5525" (14.006 - 14.033 mm)
	Rocker Shaft Bore I.D. (Intake and Exhaust)	0.5514" - 0.5525" (14.006 - 14.033 mm)
Cylinder Head	Cylinder Head - Surface warp limit	0.004" (0.1 mm)
	Cylinder Head - Standard height	3.611" (91.71 mm)
Valve Seat	Valve Seat - Contacting Width - Intake	0.047" \pm 0.008" - 0.0039" (1.20 \pm 0.20 mm)
	Valve Seat - Contacting Width - Exhaust	0.047" \pm 0.008" - 0.0039" (1.20 \pm 0.20 mm)
	Valve Seat Angle	45.5° \pm 0.25°
Valve Guide	Valve Guide Inner diameter	0.217" + .0005" - 0.0 (5.52 + .012 - 0.0 mm)
	Valve Guide Protrusion Above Head - Intake	0.361" \pm 0.010" (9.18 \pm 0.25 mm)
	Valve Guide Protrusion Above Head - Exhaust	0.276" \pm 0.010" (7.00 \pm 0.25 mm)
Valve	Valve Lash (Cold) - Intake	0.006" (.152 mm \pm 0.025 mm)
	Valve Lash (Cold) - Exhaust	0.009" (.228 mm \pm 0.025 mm)
	Valve Margin Thickness - Intake	0.016" (.41 mm)
	Valve Margin Thickness - Exhaust	0.023" (.59 mm)
	Valve Stem Diameter - Intake	0.2163" \pm 0.0003" (5.495 \pm 0.0075 mm)
	Valve Stem Diameter - Exhaust	0.2159" \pm 0.0003" (5.485 \pm 0.0075 mm)
	Valve Stem Oil Clearance - Intake	0.0014" \pm 0.0005" (0.035 \pm 0.0135 mm)
	Valve Stem Oil Clearance - Exhaust	0.0018" \pm 0.0005" (0.045 \pm 0.0135 mm)
	Valve Stem Overall Length - Intake	4.6681" \pm 0.012" (118.57 \pm 0.30 mm)
	Valve Stem Overall Length - Exhaust	4.5649" \pm .012" (115.95 \pm 0.30 mm)
Valve Spring	Valve Spring Free Length	1.861" (47.26 mm)
	Valve Spring Installed Height	Intake - 1.650" (41.91 mm) Exhaust - 1.650" (41.91 mm)

ENGINE

CYLINDER / PISTON (IN. / MM)		
Cylinder	Cylinder - Surface warp limit (mating with cylinder head)	0.004" (0.10 mm)
	Cylinder Bore - Standard	3.4252" ± .0005 (87 mm ± .01mm)
	Cylinder Out of Round Limit	0.0003" (0.0075 mm)
	Cylinder to Piston Clearance	.0021" ± .0013" (.053 ± .03mm)
Piston	Piston - Standard O.D. - Measured 90 degrees to pin, 1.3 in. (33.0 mm) down from piston crown.	3.4231" ± .0008" (86.947 ± .02 mm)
	Piston Pin Bore I.D. (Standard)	0.7877" ± .0002" (20.007 ± .004 mm)
Piston Pin	Piston Pin Outside Diameter	0.7873" ± .0001" (19.9975 ± .0025 mm)
	Piston Pin - Standard Clearance - Piston Pin to Pin Bore	0.0004" ± .0002" (0.0095 ± 0.0065 mm)
	Piston Pin - Degree of Fit	Piston pin must be a push fit (by hand) at 68° F (20° C)

PISTON / RINGS / CONNECTING ROD / CRANKSHAFT (IN. / MM)			
Piston Ring	Installed Gap	Top Ring - Standard	0.008" - 0.014" (0.20 - 0.36 mm)
		Top Ring - Service Limit	0.016" (0.41 mm)
		Second Ring - Standard	0.014" - 0.024" (0.36 - 0.61 mm)
		Second Ring - Service Limit	0.032" (0.81 mm)
		Oil Ring Rails - Standard	0.020" ± 0.010" (0.51 ± 0.25 mm)
		Oil Ring Rails - Service Limit	0.032" (0.81 mm)
	Ring to Groove Clearance	Top Ring - Standard	0.0024" ± 0.0008" (0.060 ± 0.020 mm)
		Second Ring - Standard	0.0028" ± 0.0008" (0.070 ± 0.020 mm)
Connecting Rod	Connecting Rod Small End I.D.		0.7886" + 0.000 / - .015" (20.030 + 0.000 / - .015 mm)
	Connecting Rod Small End Diametral Clearance		0.00098" ± .0004" (0.025 ± 0.010 mm)
	Connecting Rod Big End Side Clearance		0.012" ± 0.0039" (0.30 ± .10 mm)
	Connecting Rod Big End Diametral Clearance		0.0098" - .0023" (0.025 - .059 mm)
Crankshaft	Crankshaft Runout Limit (See procedure)		
		PTO End	Less than .001" (0.025 mm)
		MAG End	Less than .001" (0.025 mm)
	Main Journal Diameter (Standard)		2.1642" - 2.1649" (54.97 - 54.99 mm)
	Connecting Rod Journal Diameter (Standard)		1.7718" - 1.7726" (45.005 - 45.025 mm)

ENGINE ASSEMBLY VIEWS AND TORQUE VALUES

Torque & Torque Sequence - Main Engine Components

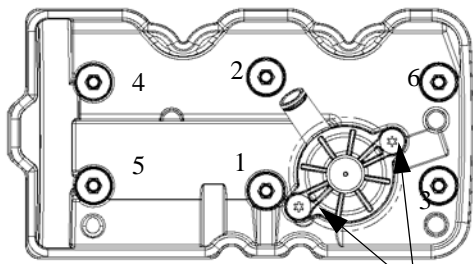

89 lb-in. (10 Nm) 13 lb-ft. (18 Nm)
VALVE COVER

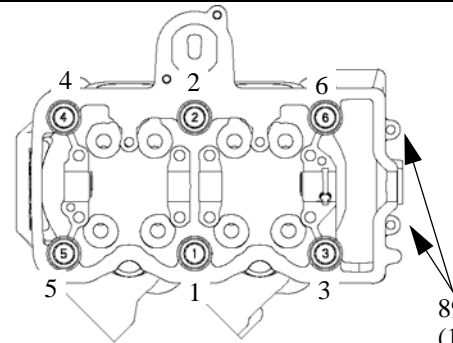

26 lb-ft. (35 Nm) + 90° (see procedure) 89 lb-in. (10 Nm)
CYLINDER HEAD

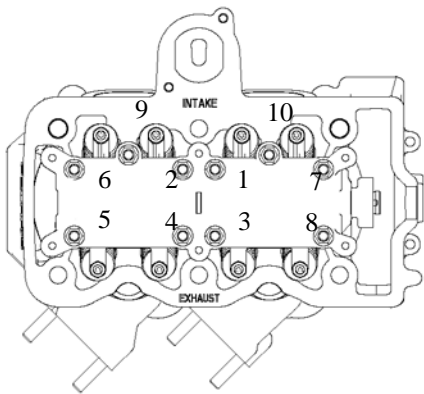

13 lb-ft. (18 Nm)
CAMSHAFT CARRIER

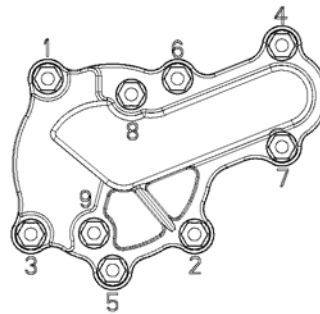

9 lb-ft. (12 Nm)
OIL PUMP COVER

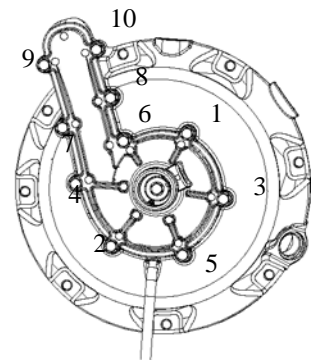

89 lb-in. (10 Nm)
WATER PUMP COVER

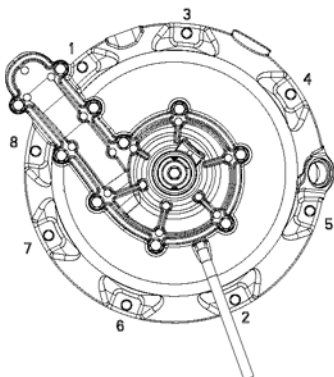

89 lb-in. (10 Nm)
STATOR COVER

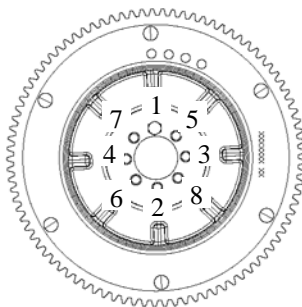

14 lb-ft. (19 Nm)
STARTER GEAR

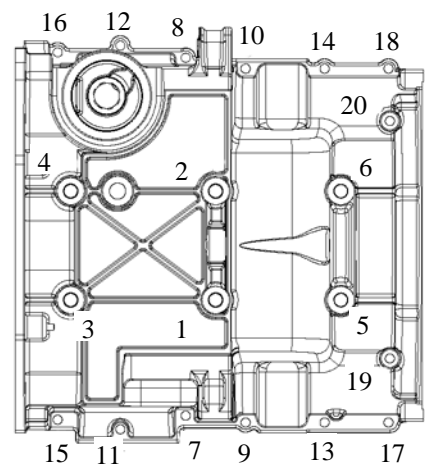

M9 = 26 lb-ft. (35 Nm)
M6 = 89 lb-in. (10 Nm)
CRANKCASE

5

ENGINE

Valve Cover / Breather Valve

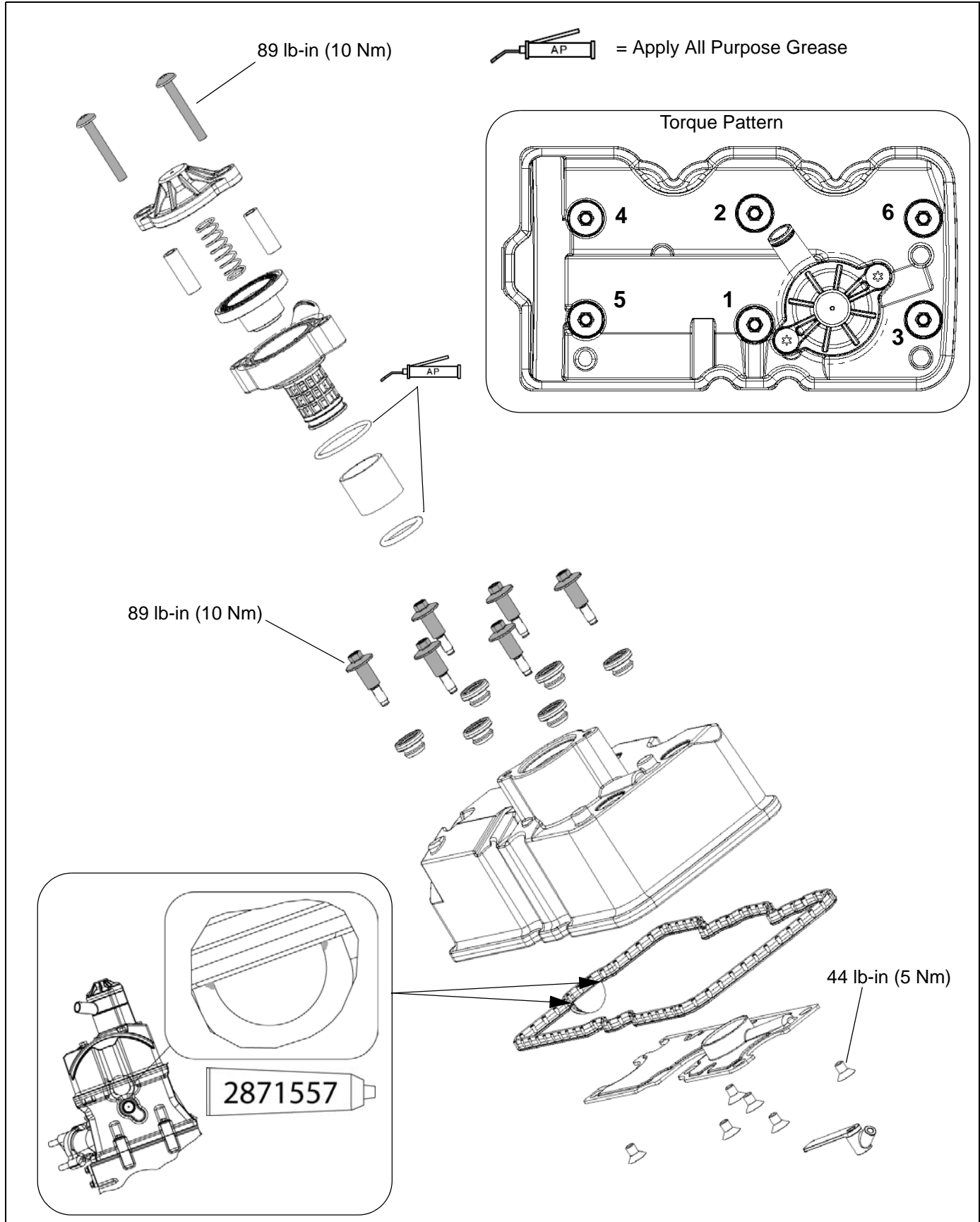

Camshaft Carrier / Camshaft / Rocker Arm

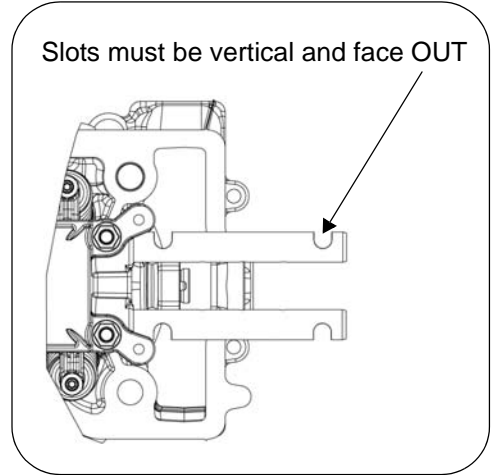
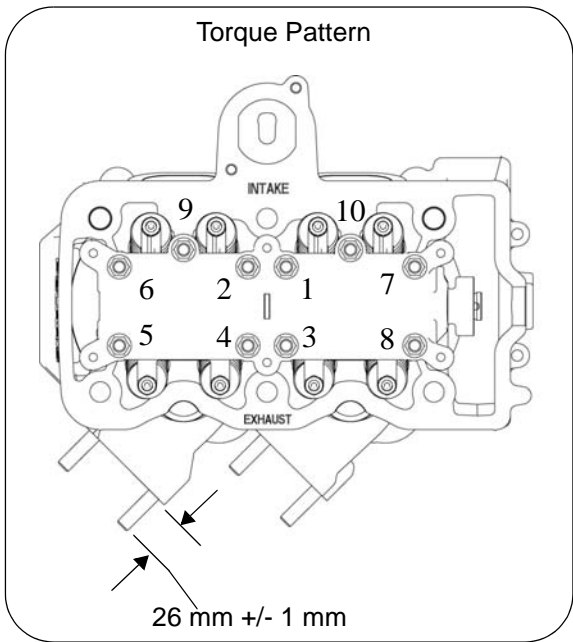

1. Crankshaft at TDC MAG cylinder
2. Camshaft pin at 10:00 position
3. Snug all bolts
4. Torque to 13 lb-ft. (18 Nm) following torque pattern

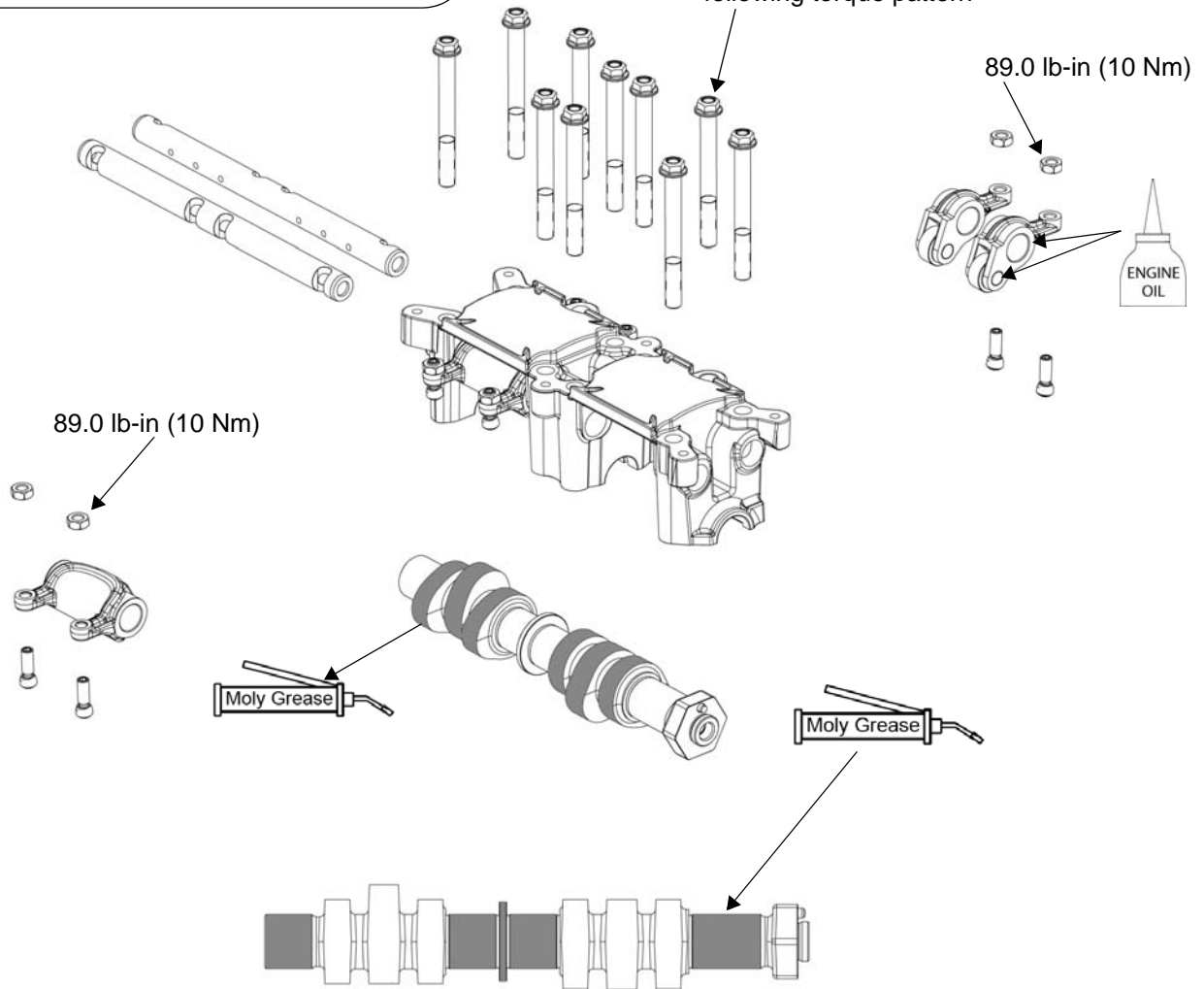

ENGINE

Cylinder Head / Valve / IAFM

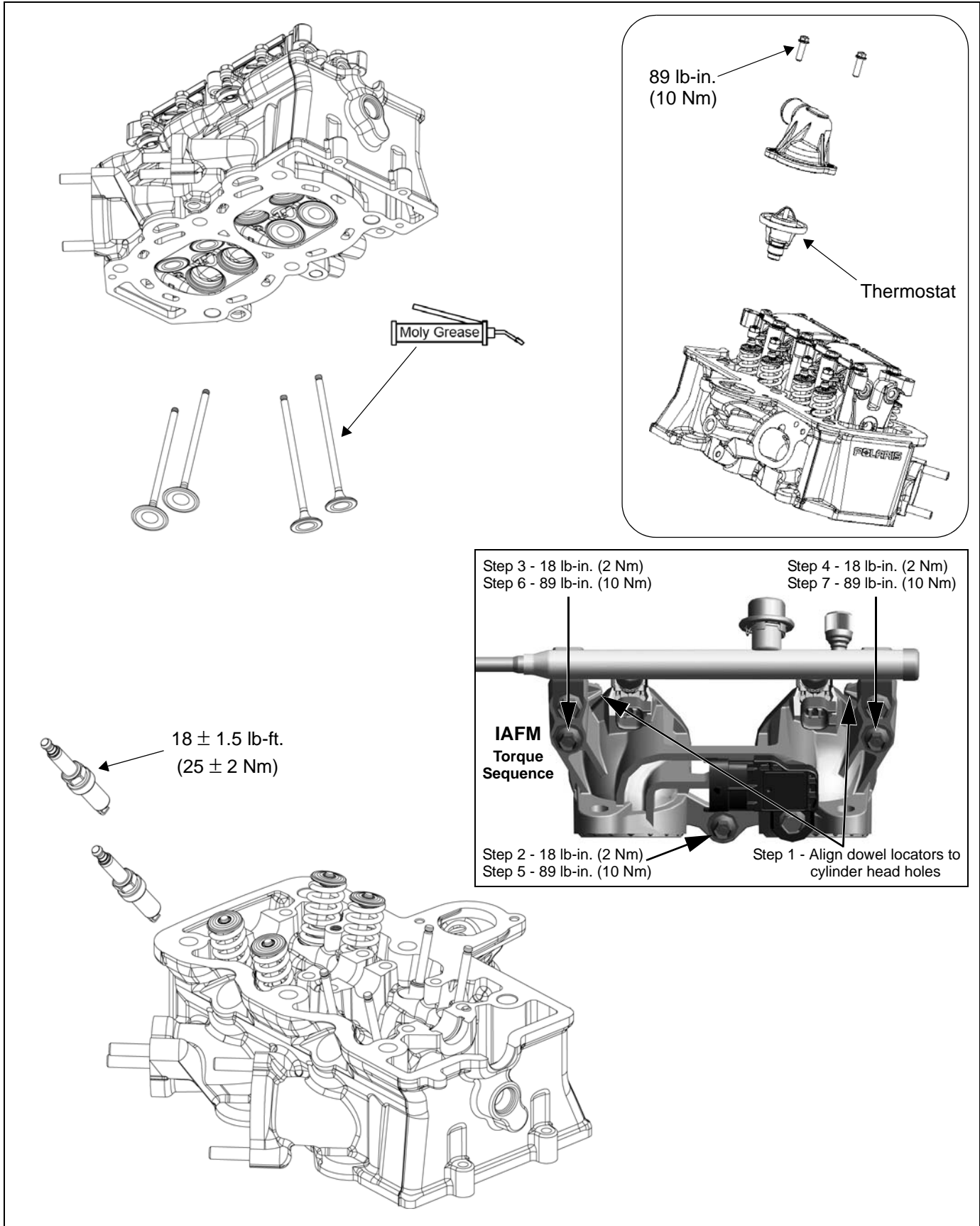

Valve & Spring Height Detail

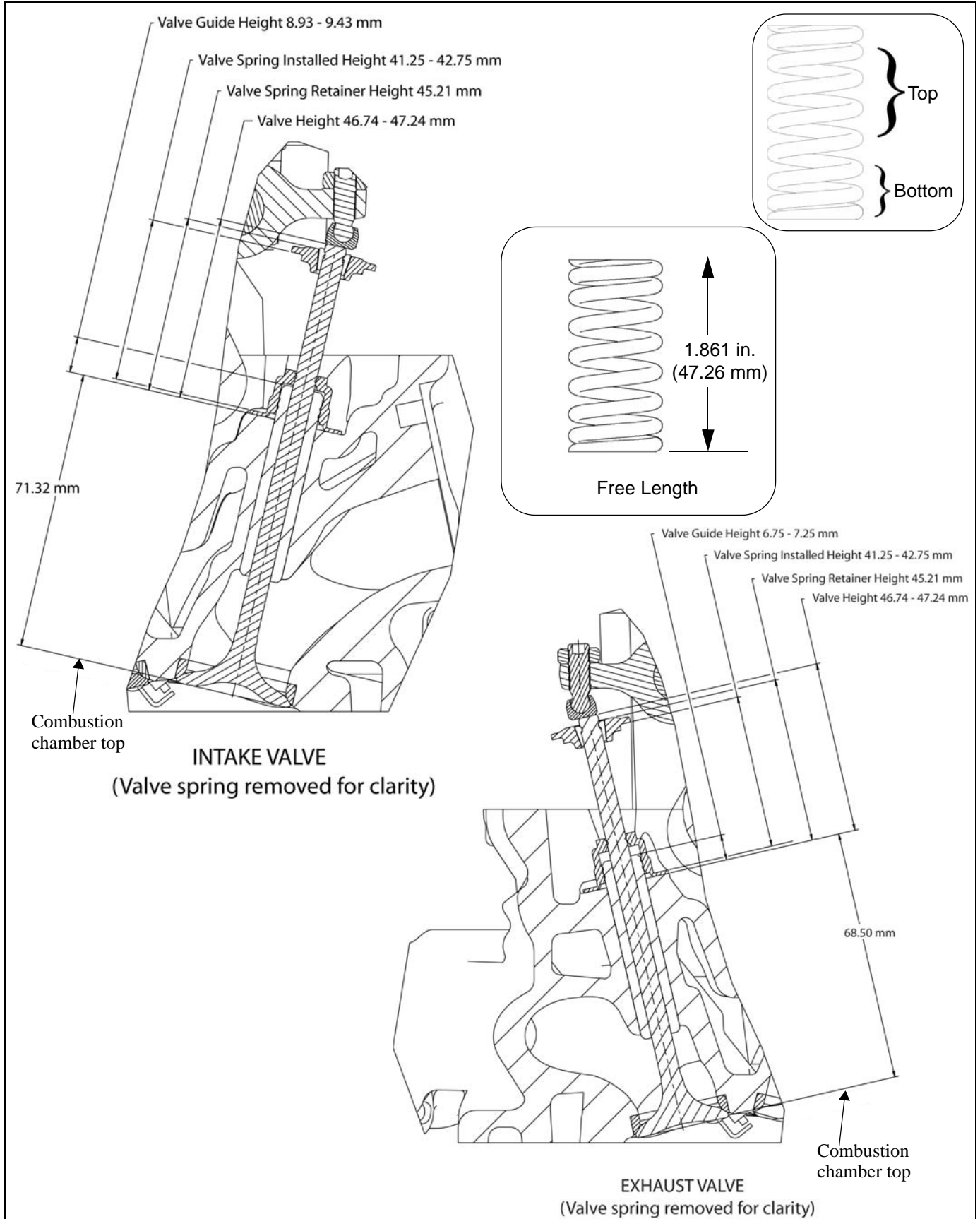

ENGINE

Piston / Connecting Rod

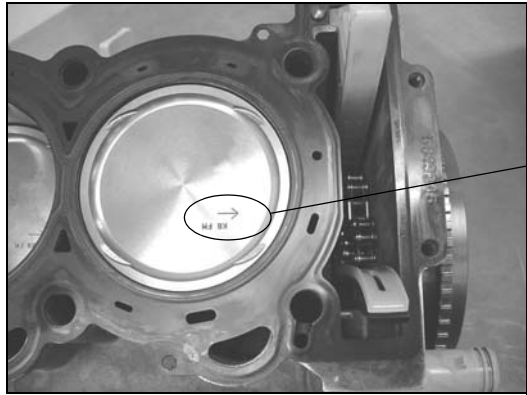

Arrow to MAG end (toward cam chain)

Place circlip gap at top or bottom

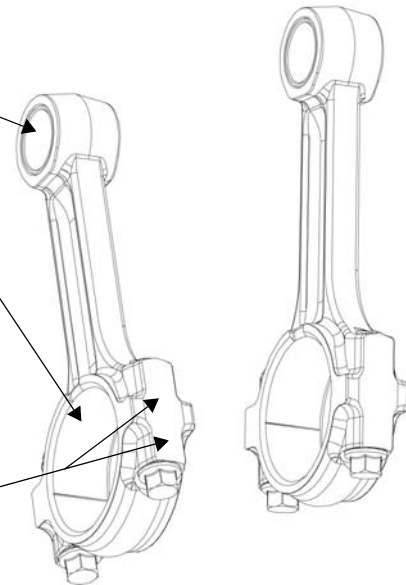
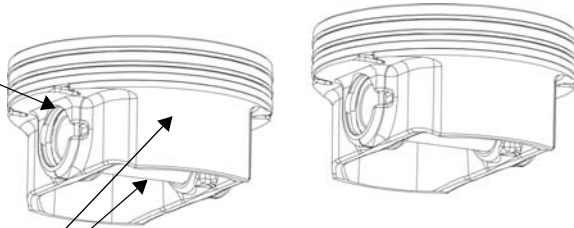

Match stamp on rod and cap.
Rod stamp can face front or rear of engine
(Rod has no offset)

Install NEW rod bolts if disassembled
1. Torque bolts to 24 lb-ft (33 Nm)
2. Tighten bolts an additional 60°

Tighten bolt to align mark on bolt with mark on rod cap (60°)

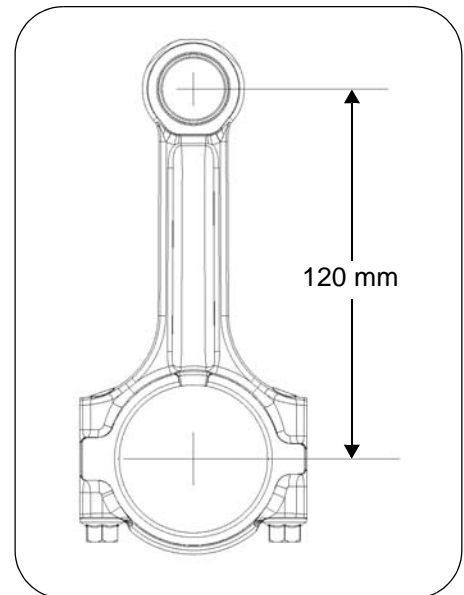
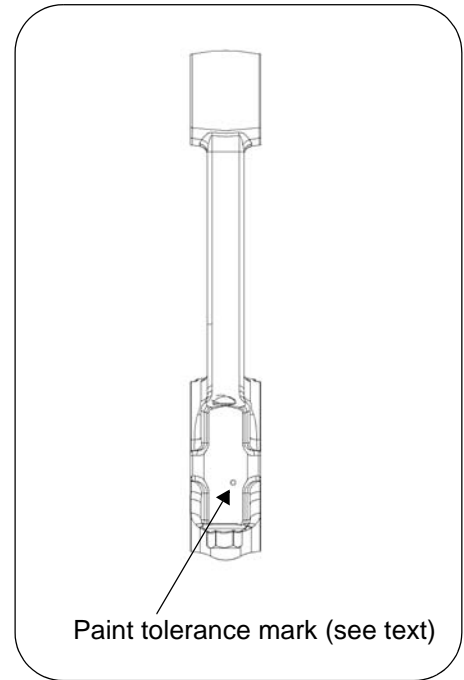
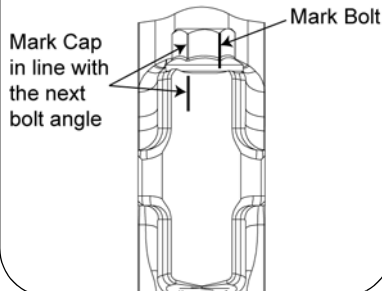

Crankshaft

Main Journal O.D.

54.98 mm \pm .01
(2.1646" \pm .0004)

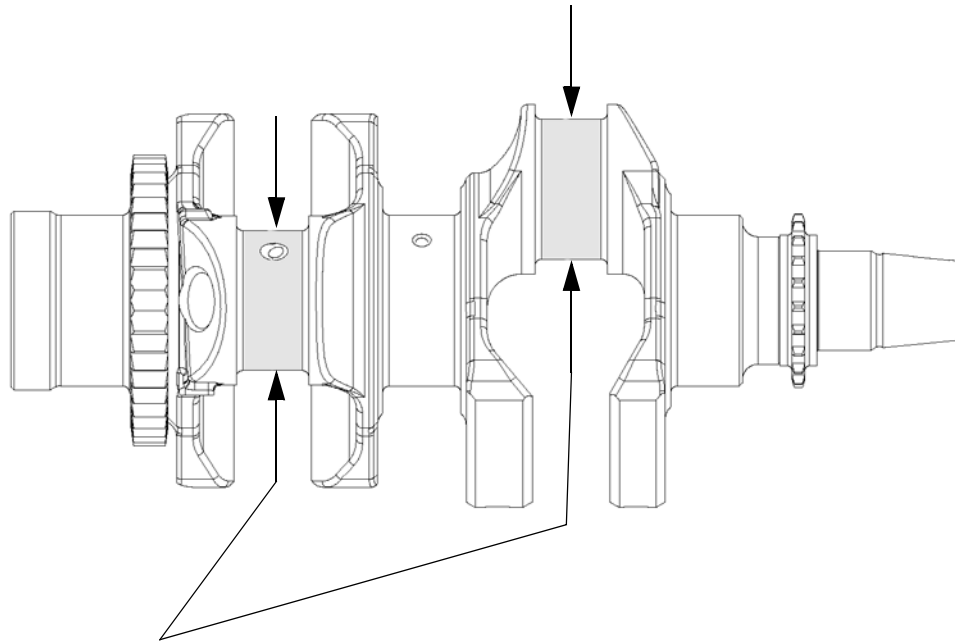
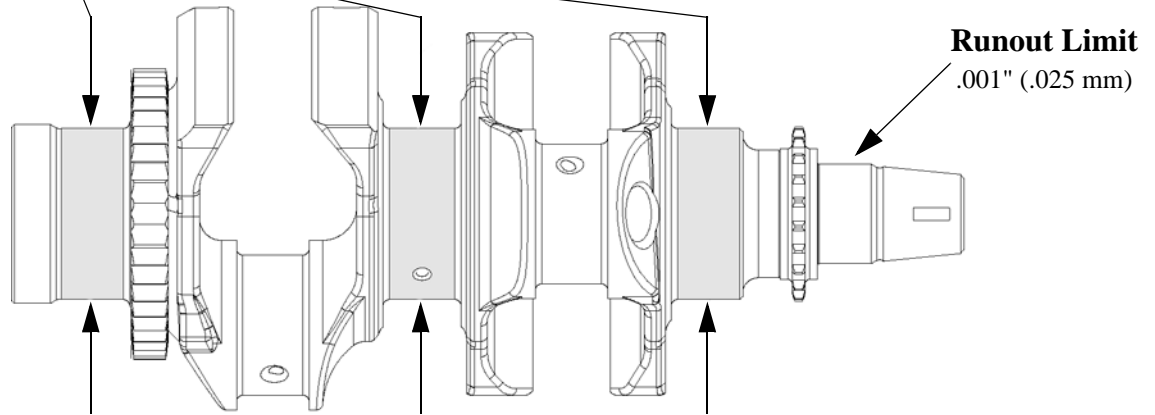
**Connecting Rod Journal O.D.**

45.015 mm \pm .01 (1.7722" \pm .0004)

Refer to bearing selection procedure and chart on page 5.48.

ENGINE

Crankcase

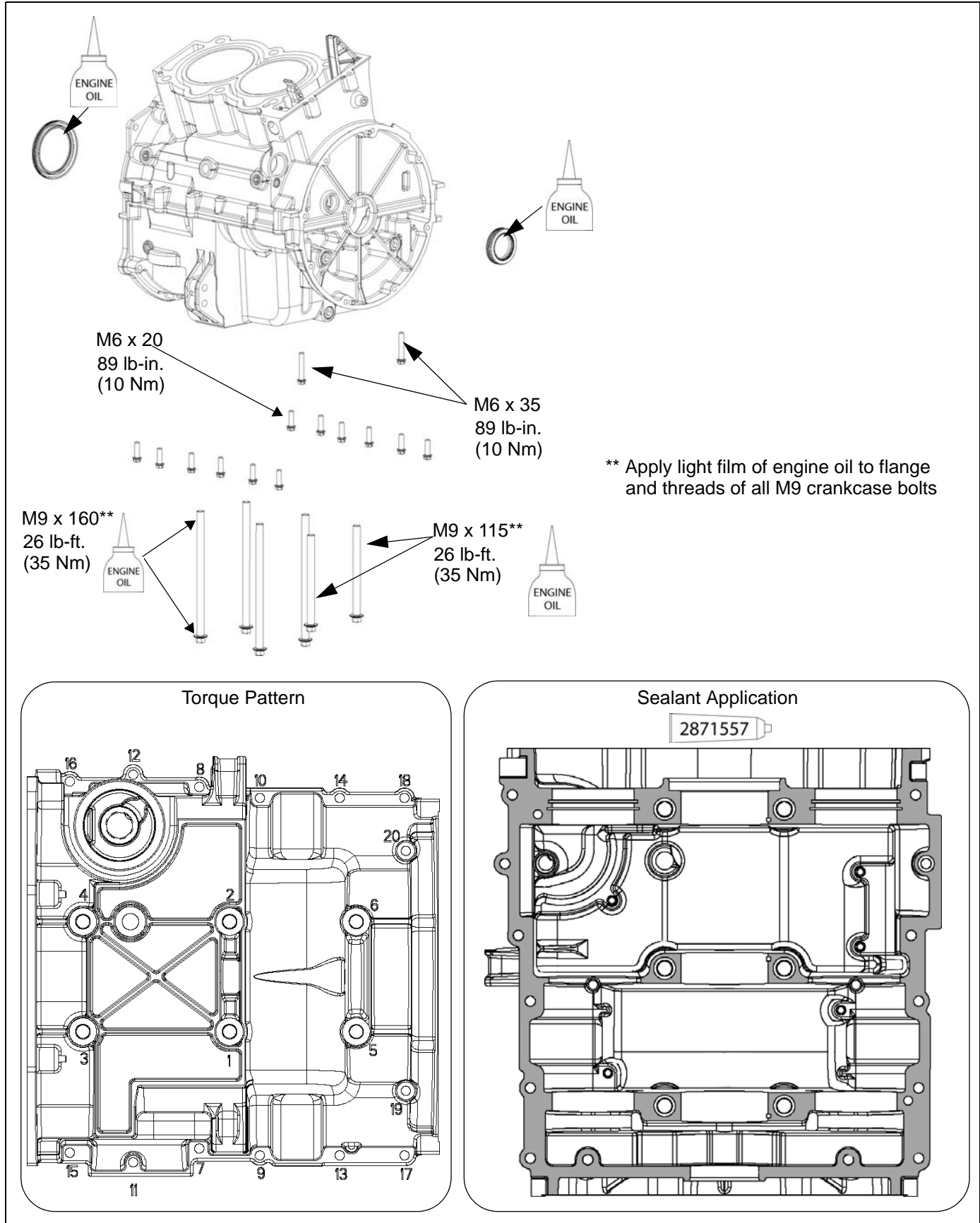

Crankcase - Upper

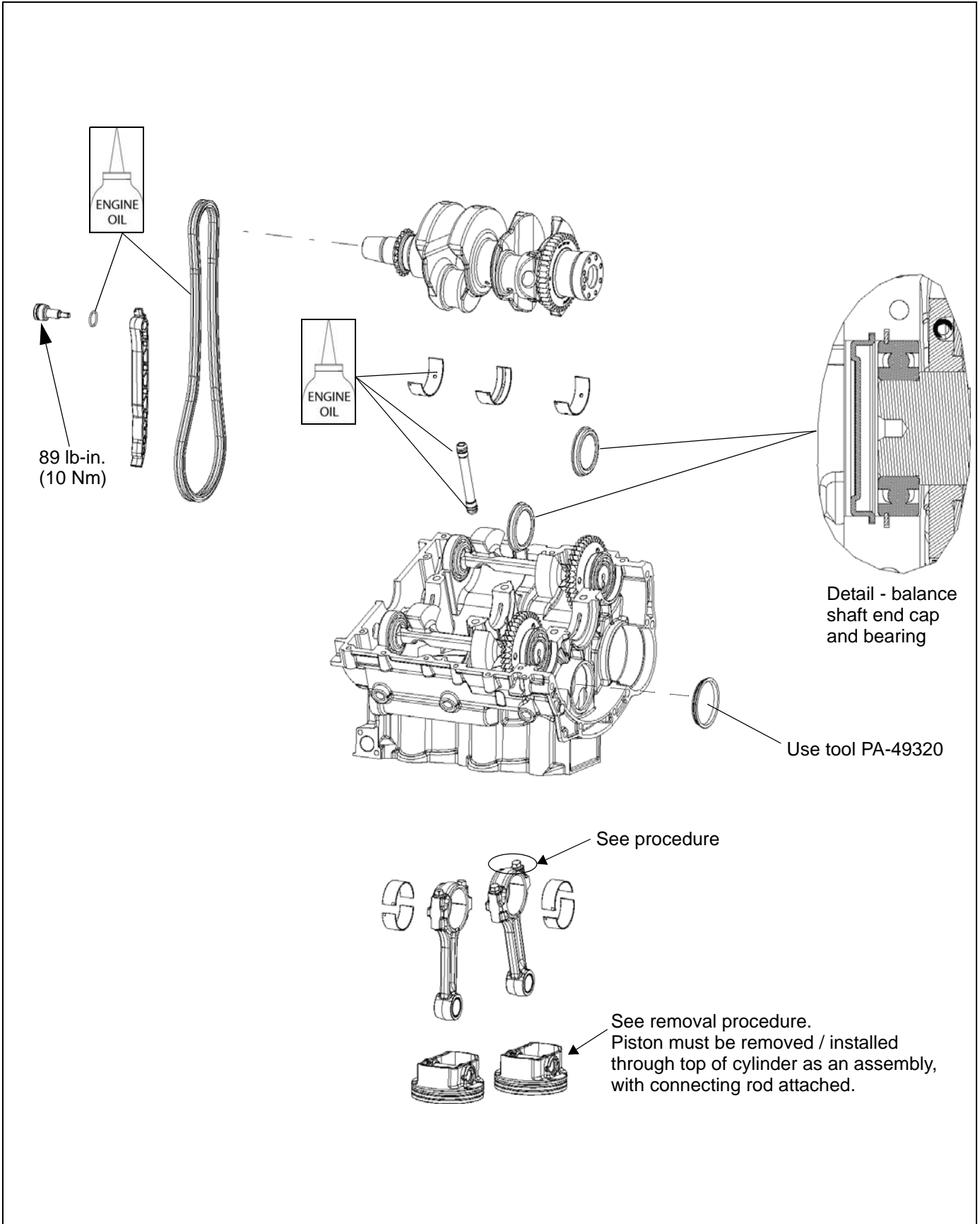

5

ENGINE

Balance Shaft / Balance Shaft Timing

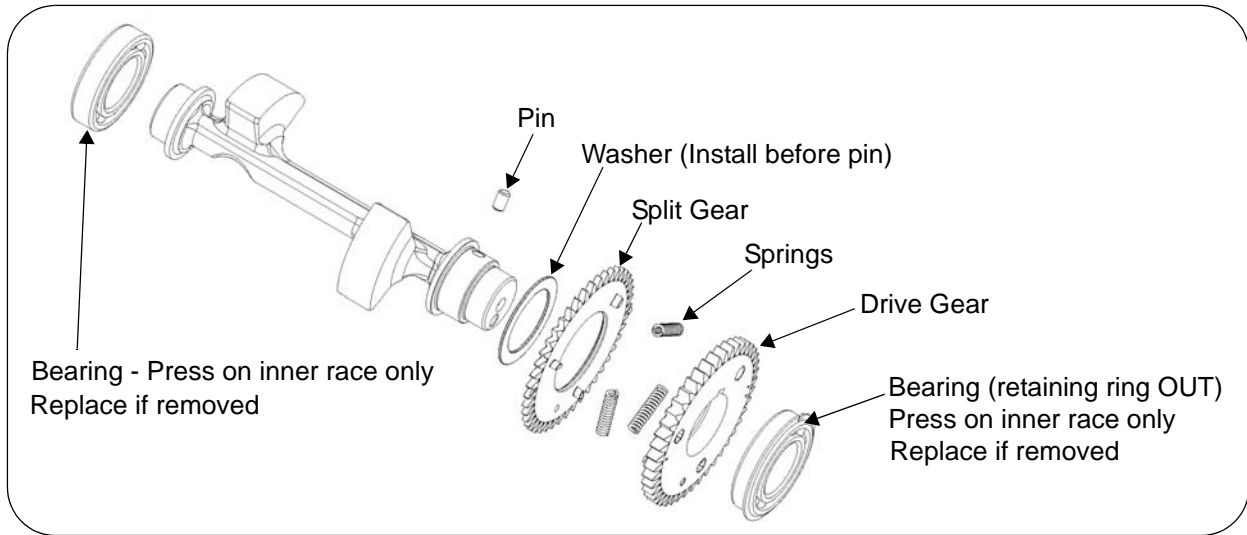

Balance Shaft Timing at TDC on MAG Cylinder

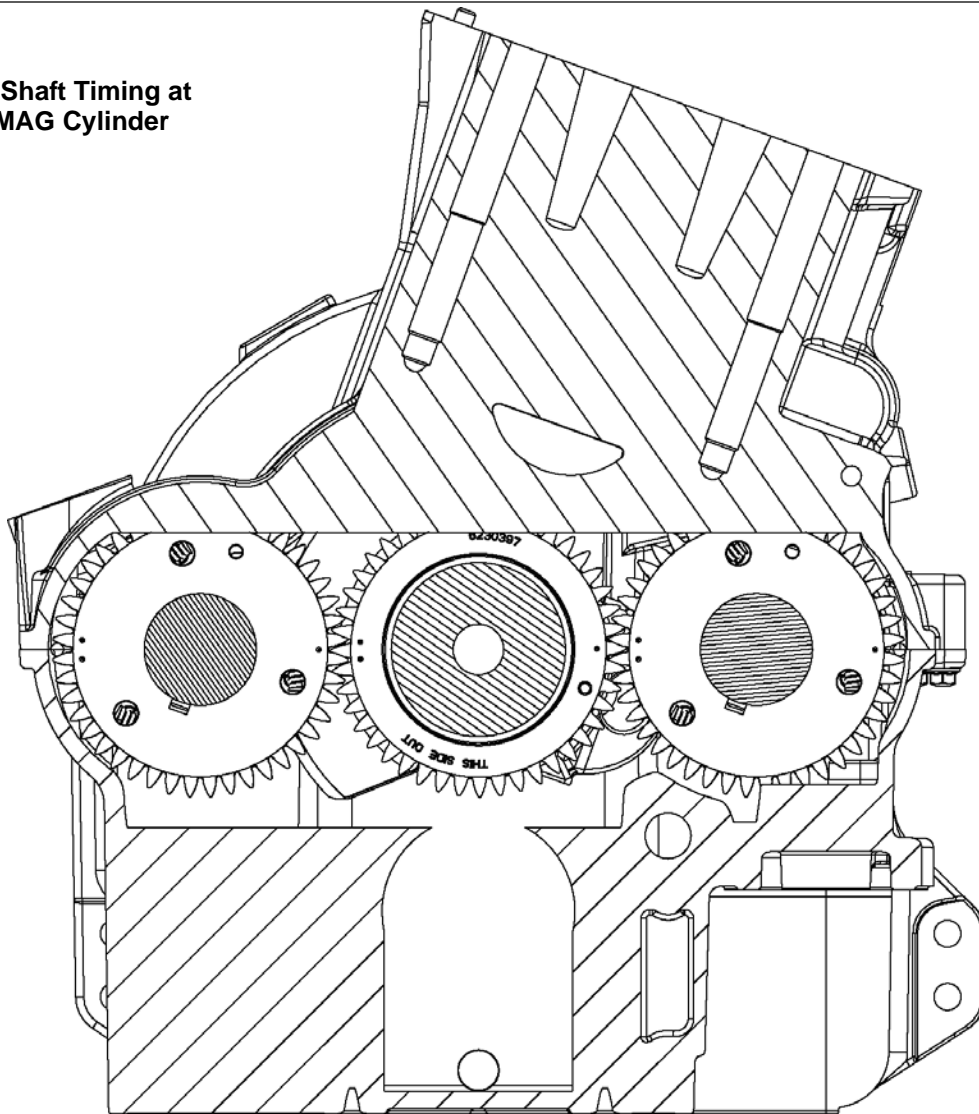

Crankcase (Lower) With Oil Pump

See "Crankcase (Lower) / Oil Pump Disassembly" on page 5.41

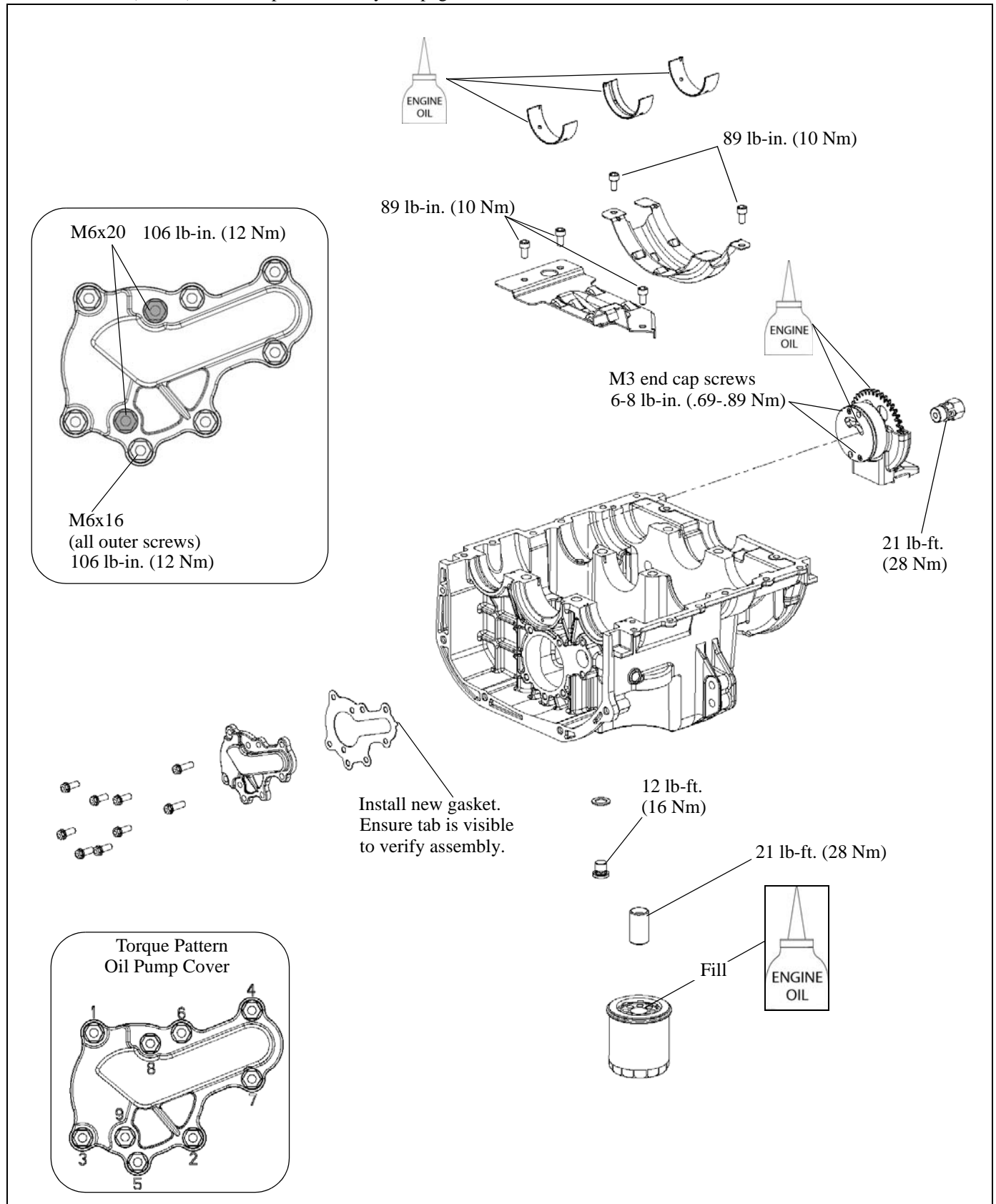

ENGINE

Water Pump Coupler

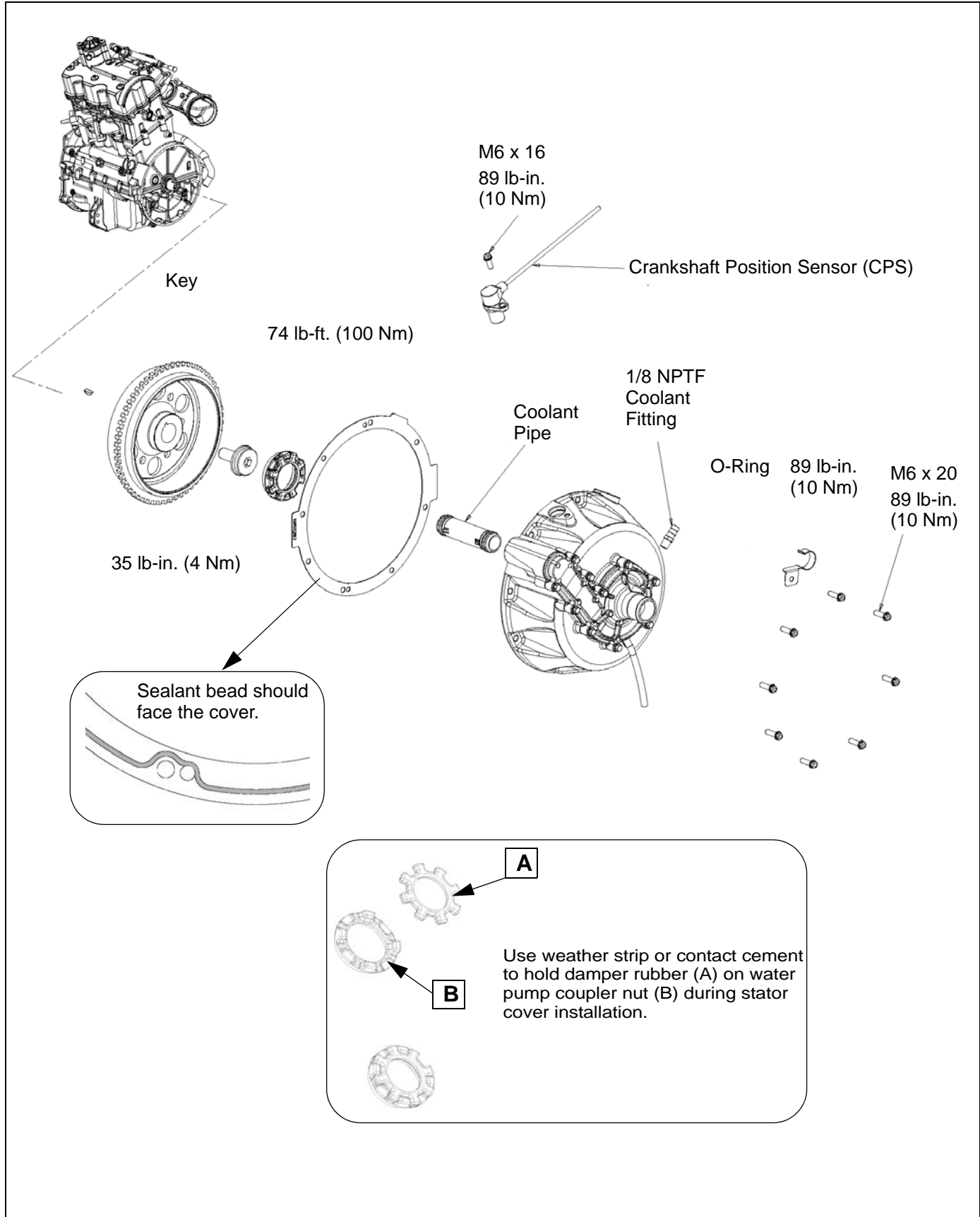

Water Pump / Water Pump Coupler / Stator / Flywheel

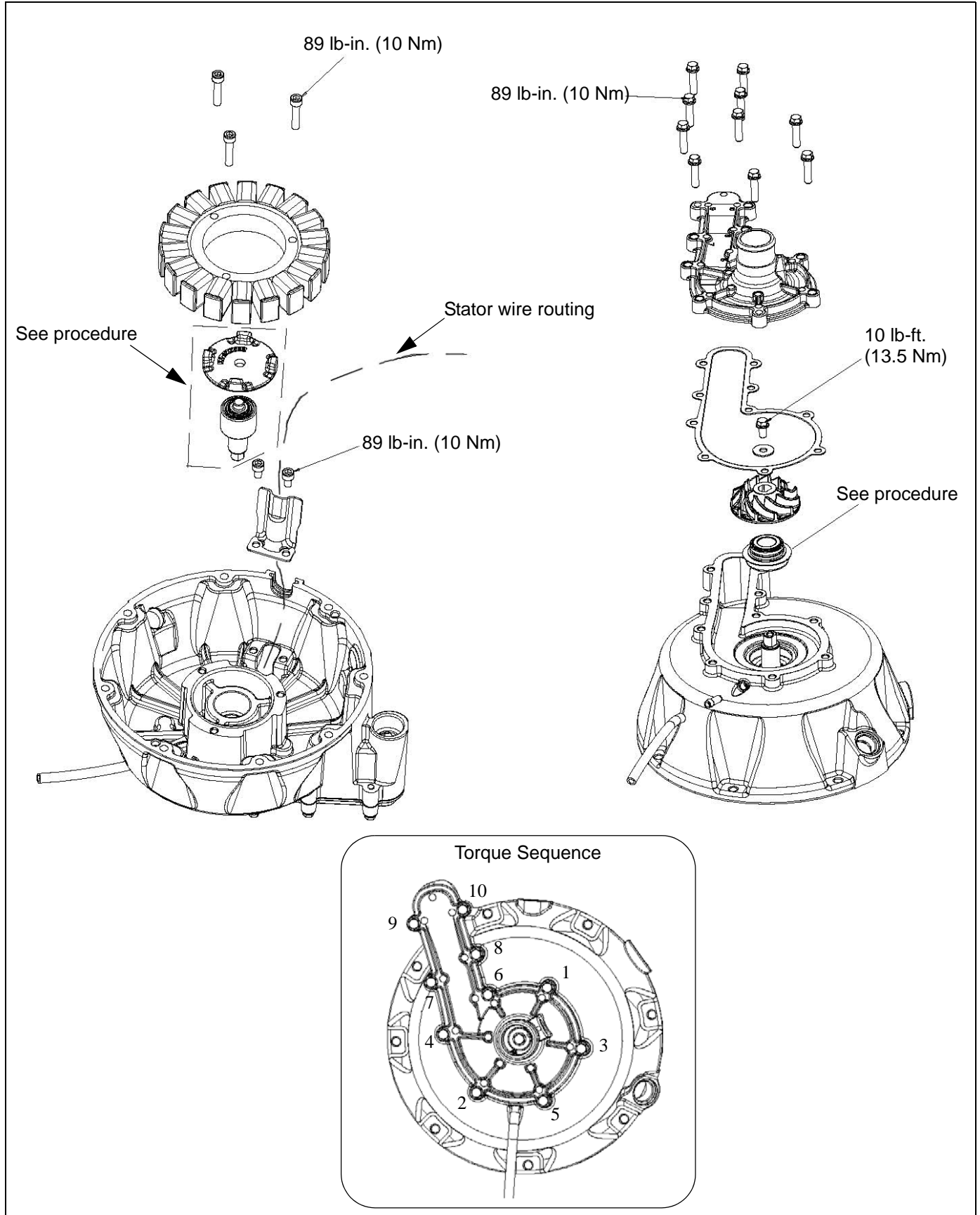

ENGINE

Drive Coupler (Rear) / Starter Gear

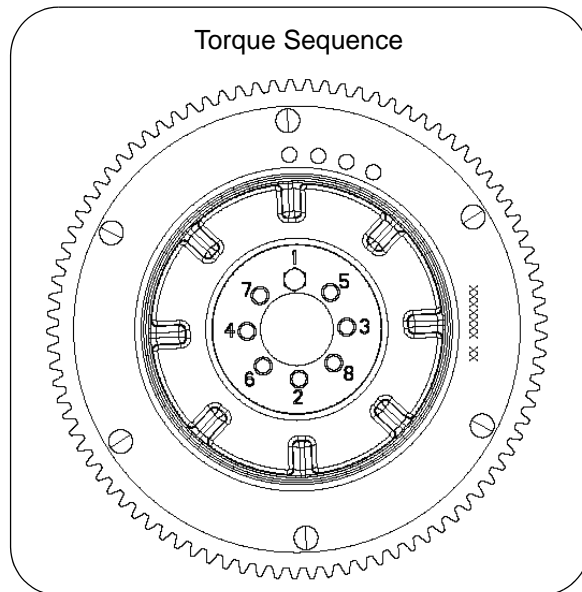
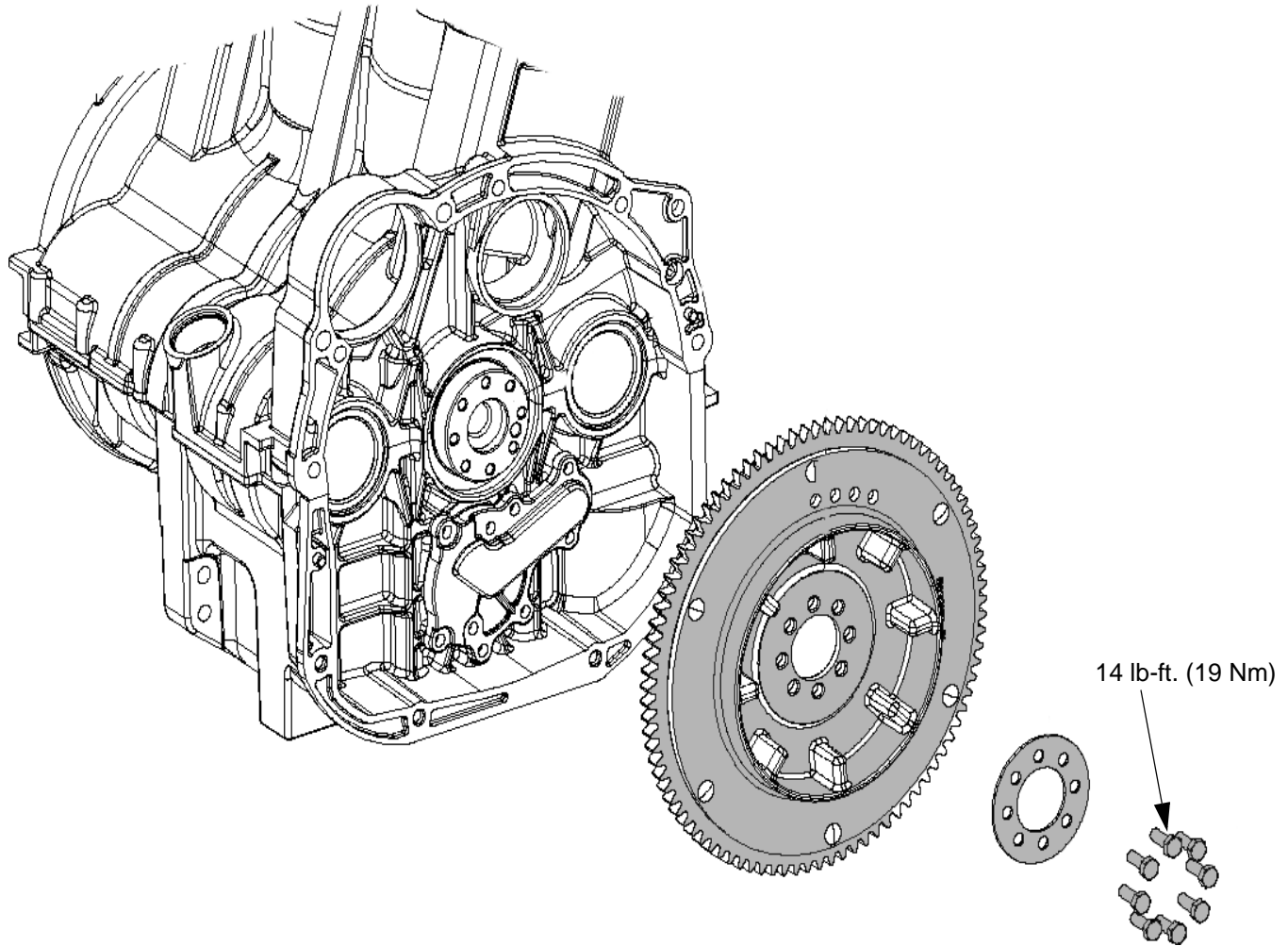

ENGINE SERVICE

Accessible Engine Components

Components serviceable with engine installed:

- Flywheel
- Alternator (Stator)
- Starter Motor/Drive
- Cylinder Head / Valves
- Camshaft / Camshaft Carrier
- Rocker Arms
- Water Pump

Components that require engine removal for service:

- Counterbalance Shaft(s)
- Piston / Rings
- Connecting Rod
- Crankshaft / Main Bearings
- Oil Pump
- Crankcase
- Crankshaft End Seals (Use Driver PA-49320)

Top-End Service (Engine in Chassis)

The top-end of the engine can be serviced while the engine is mounted in the chassis. A removable upper right-hand frame support allows access to the valve cover and cylinder head.

To service the top-end of the engine refer to the “Valve Clearance Adjustment” procedure in Chapter 2, which provides detailed steps to access the valve cover.

Crankcase Cylinder Service Information

IMPORTANT: Identify which engine you are servicing before replacing components such as the pistons.

It is important to note that two types of engine crankcases were produced for the 2009 Sportsman XP 850. Some of the engines produced have NiCaSil plated cylinder walls, while others have iron lined cylinder walls.

The crankcase differences can be easily recognized by their physical appearance.

- A dull, dark gray color identifies the NiCaSil plated.
- A shiny metallic color identifies the iron lined.

The crankcase differences can also be identified by viewing the engine designation portion of the vehicle’s model number.

- NiCaSil Plated: A09ZN85
- Iron Lined: A09ZN8X.

Engine Removal

IMPORTANT: Some engine repair procedures can be performed without removing the engine from the vehicle. Refer to “Accessible Engine Components” for further information.

NOTE: Upon engine removal, use a mechanical lift or have an assistant help remove the engine from the vehicle to prevent personal injury or damage to vehicle components.

1. If vehicle was recently operated, allow it to cool down before attempting to perform any work.
2. Thoroughly clean the engine and chassis.
3. Clean your work area
4. Drain the engine oil (see Chapter 2 “Maintenance”).
5. Remove the following body components. Refer to Chapter 9 “Body / Frame” for component removal.
 - Seat
 - Side Panels (upper and lower)
 - Footwells
 - Mud Guards (both sides)
6. Disconnect negative (-) battery cable.
7. Pull the shift linkage rod straight outward while pushing on the two ears of the snap retainer to disconnect the rod from the shift lever. Allow the linkage to hang down out of the way.

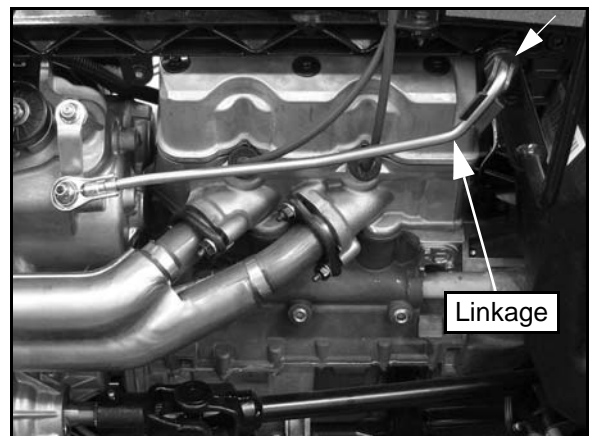

ENGINE

8. Remove the high tension leads from the engine and remove the (2) nuts from each exhaust flange at the engine.

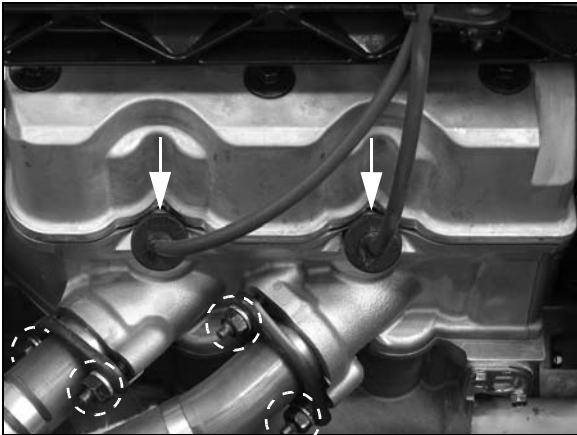

12. Disconnect the ECU from the main harness. Pull down on the connector while pulling the connector tab out.



9. Remove the exhaust springs retaining the exhaust pipe to the silencer and remove the pipe from the vehicle. Insert a clean shop towel into the engine exhaust ports.

10. Remove the breather line from the valve cover breather.

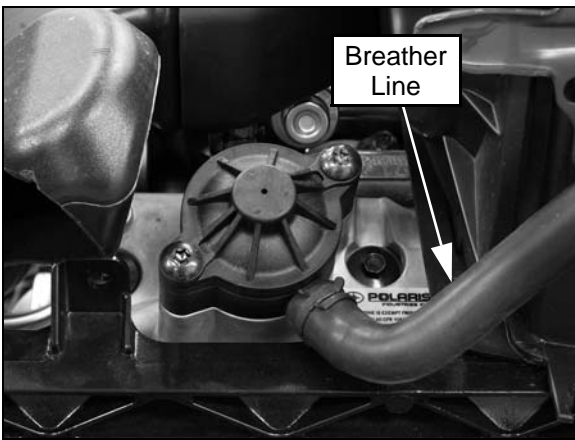

13. Disconnect the harness and ground wire from the ignition coil located on the right side of the air box.

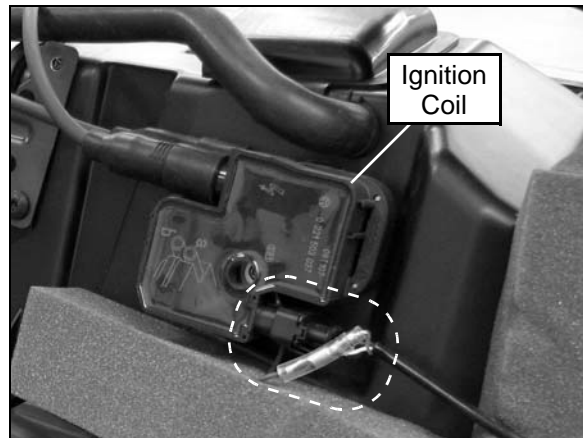

11. Using an 8 mm Allen socket, remove the (4) bolts and upper right-hand frame support to allow engine removal.

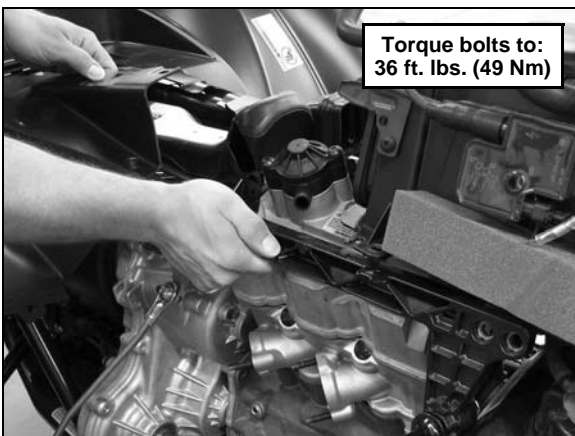

14. Remove the (2) screws from the rear portion of the air box, disconnect the intake boot from the intake plenum and remove the air box from the vehicle.

15. Depressurize the fuel system at the fuel valve. Disconnect the fuel line fitting from the fuel rail and remove the fuel tank (see Chapter 3 "Fuel Pump / Fuel Tank Removal").

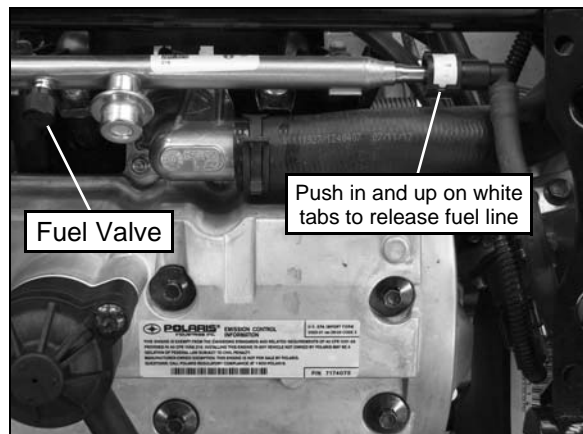

16. Remove the (4) screws retaining the engine skid plate and remove the plate from the vehicle.
17. Place a drain pan under the front portion of the engine.
18. Slide the clamp back and remove the coolant inlet hose from the water pump housing.

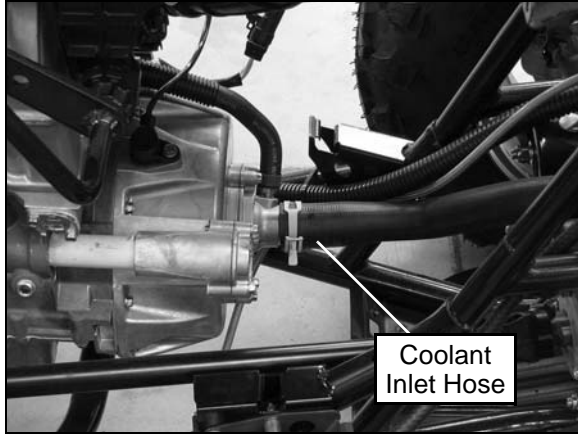

19. Slowly drain the coolant into the drain pan. Dispose of used coolant properly.



20. Disconnect the stator and CPS wire harnesses.

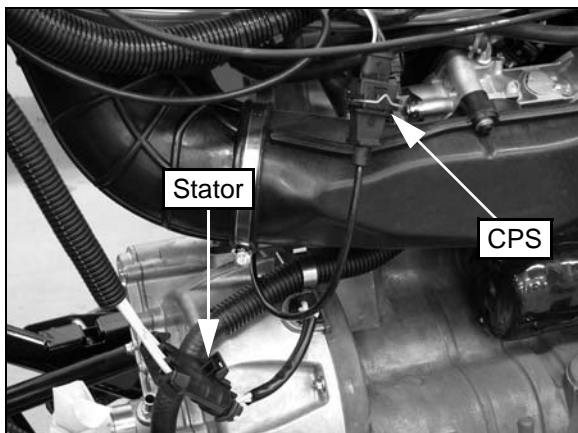

21. Use the Roll Pin Removal Tool (PN 2872608), to drive out the roll pin from the front propshaft. Pull the shaft back towards the transmission to remove it from the front gearcase input shaft, then pull it forward to remove it from the transmission output shaft.

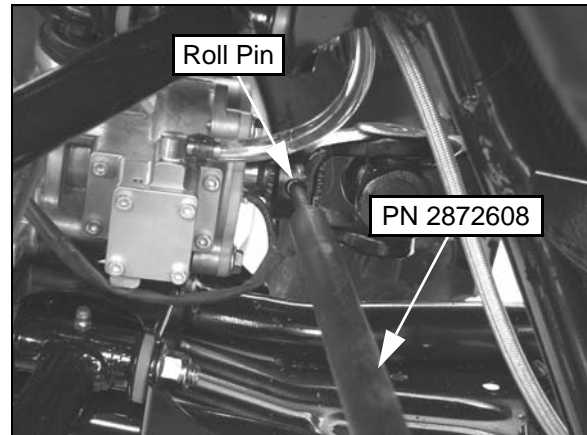

22. Remove all bolts from both sides retaining the engine to the transmission.

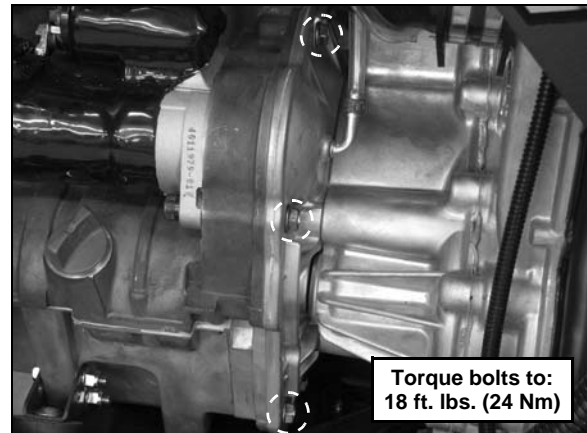

23. Remove the **top** bolt from the RH engine isolator mount.

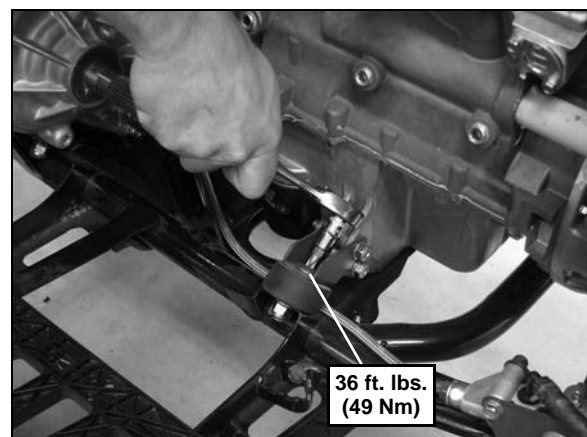

ENGINE

24. Remove the (2) through-bolt fasteners retaining the LH engine isolator mount to the engine and remove the lower nut from the mount. Pry up between the frame and isolator mount and remove the mount assembly from the frame.

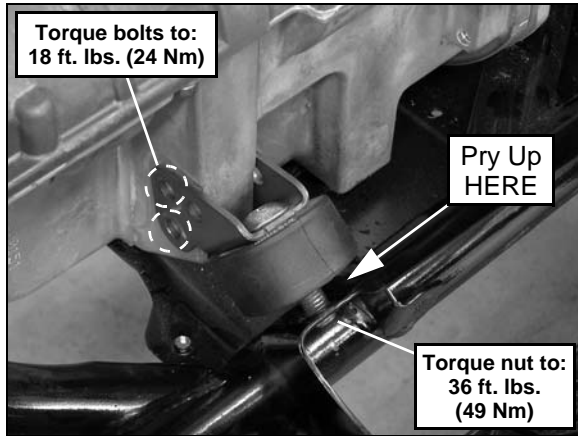

25. Remove the upper radiator hose from the thermostat housing. Insert a clean shop towel into the outlet.

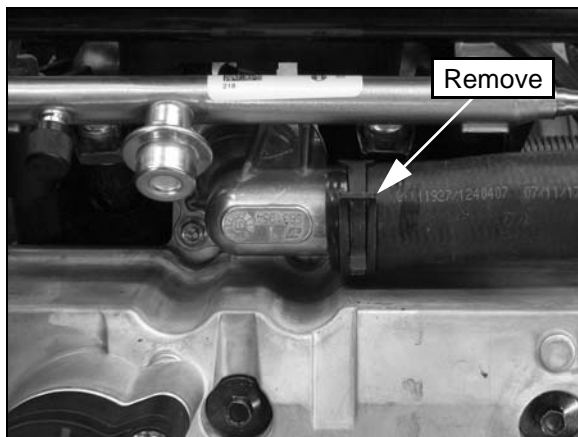

26. Remove the intake plenum from the throttle body by removing the (4) T27 Torx-head screws. Reinstall the screws into the throttle body to hold it in place until removed later in this procedure.

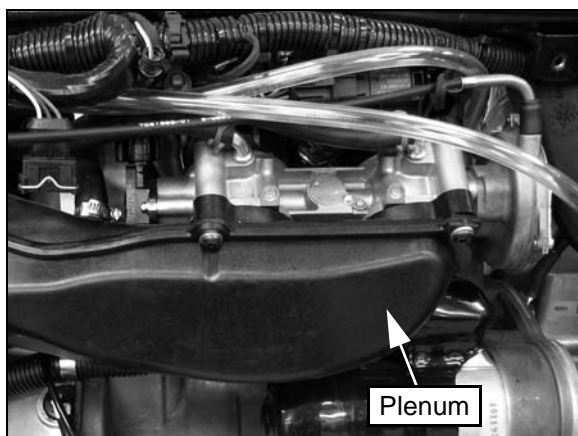

27. Remove the (2) screws retaining the IAC mount plate to the frame at the front of the engine.

28. Disconnect the wire harness from the IAC and TPS located on the throttle body. Remove the throttle body and IAC mount plate as an assembly with the throttle cable still attached to the throttle body.

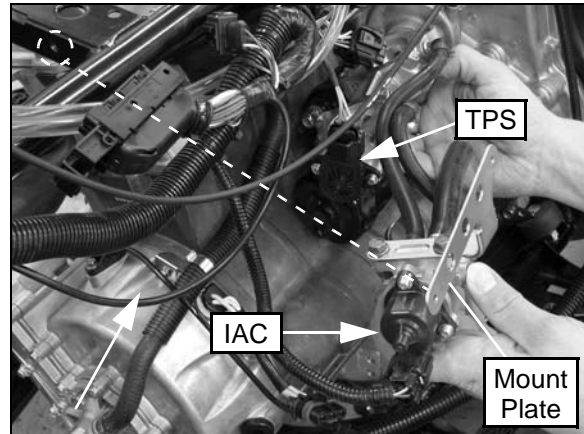

NOTE: Do not allow throttle body to hang from the throttle cable.

29. Set the assembly on top of the front cab support. Insert a clean shop towel into each intake track of the engine to prevent debris from entering.
30. Disconnect the fuel injectors at the fuel rail and disconnect the engine coolant temperature sensor located below the thermostat housing on the left side of the engine.
31. Disconnect and remove the T-MAP sensor from the intake track to prevent damage upon engine removal.
32. Remove the single spade wire (white/red) and battery cable from the starter motor solenoid.



33. Pull the engine toward the front of the vehicle to disengage the engine/transmission coupler.

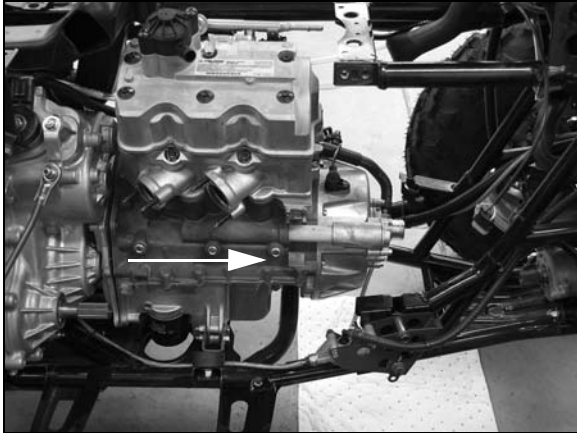

34. Remove the engine through the right side of the chassis and place on a work bench to begin engine disassembly.

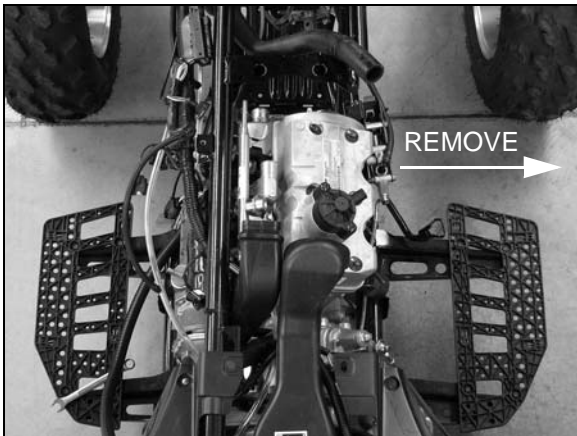

Engine Installation Notes

After the engine is installed in the frame, review this checklist and perform all steps that apply:

General Items

1. Repeat steps in reverse order in the “Engine Removal” section above to reinstall the engine.
2. Install previously removed components using new gaskets, seals, and fasteners where applicable.
3. Perform regular checks on fluid levels, controls, and all important areas on the vehicle as outlined in the Daily Pre-ride Inspection Checklist and in the Periodic Maintenance Table (refer to Chapter 2 “Maintenance”).

Exhaust

1. Replace exhaust seals before installation.
2. Install the exhaust pipe assembly into the cylinder head and exhaust silencer.
3. Install the nuts and finger tighten only!
4. Install the springs retaining the pipe to the silencer.
5. Torque the exhaust retaining nuts to specification.

Bleed Cooling System

1. Remove radiator cap and slowly add coolant to top of filler neck.
2. Fill coolant reservoir tank to full mark.
3. Install radiator cap and squeeze coolant lines to force air out of system.
4. Again remove radiator cap and slowly add coolant to top of fill neck.
5. Alternately elevate the front and back of the vehicle to allow additional air to vent from the system.
6. Start engine and observe coolant level in the radiator. Allow air to purge and top off as necessary. Reinstall radiator cap securely and bring engine to operating temp. Check coolant level in reservoir tank after engine has cooled and add if necessary.

Engine Break In Period

The engine break-in period is defined as the first 20 hours of engine operation or 2 full tanks of fuel.

1. Use only Polaris PS-4 Plus 2W-50 Synthetic engine oil. Never substitute or mix oil brands. Serious engine damage can result.
2. Use fuel with a minimum octane of 87 (R+M)/2 method.
3. Change break-in oil and filter at 25 hours.

ENGINE**ENGINE DISASSEMBLY AND INSPECTION****Valve Cover / Breather Valve**

1. Remove (2) breather housing bolts (A). Inspect bellows (B) for cracks (not required for valve cover removal).
2. Remove (6) rocker cover bolts (C) and isolators (D).
3. Replace isolators and gasket (E) if oil leaks are evident.

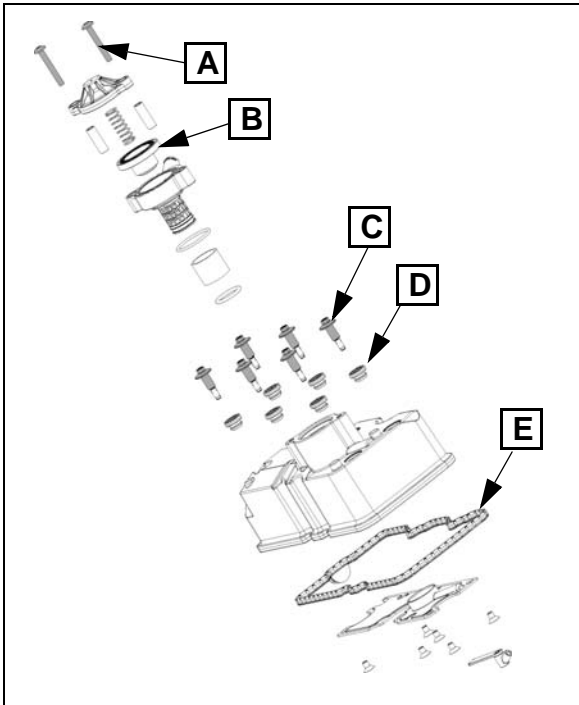
**Rocker Carrier / Camshaft Removal**

1. Rotate engine in direction of rotation until pin (A) is facing UP. Rotate cam another 60° to the 10:00 position to relieve valve spring pressure from camshaft lobes.

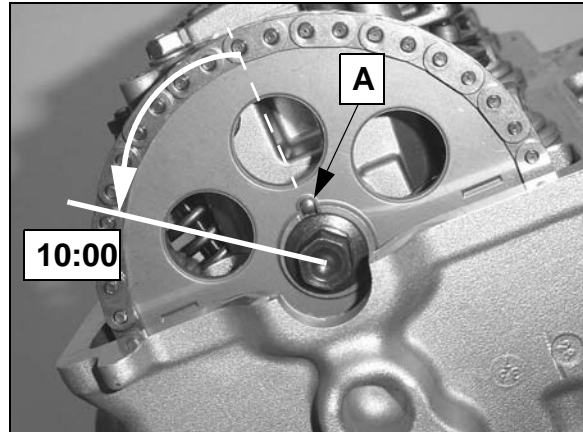

2. Remove cam chain tensioner bolts evenly and remove tensioner. Note "TOP" marked on plate for assembly.

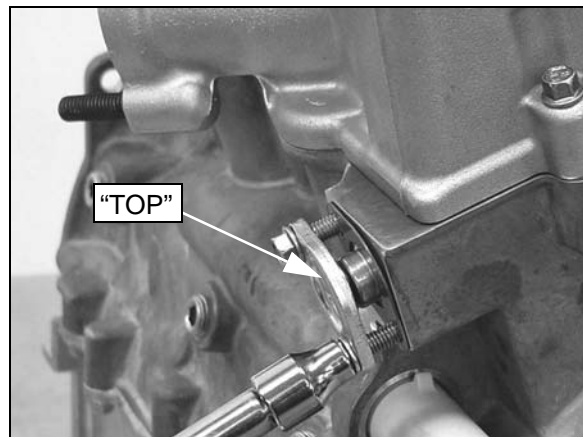

3. Remove sprocket bolt and lift chain and sprocket off camshaft. Secure cam chain with a wire (if cylinder head will not be removed).



4. Loosen all cam carrier bolts evenly and lift carrier / rocker arm assembly from cylinder head.

Rocker Arm / Rocker Arm Shaft Inspection

1. Mark or tag rocker arms and shafts to keep them in their respective locations for assembly.
2. Slide rocker arm shafts from carrier.

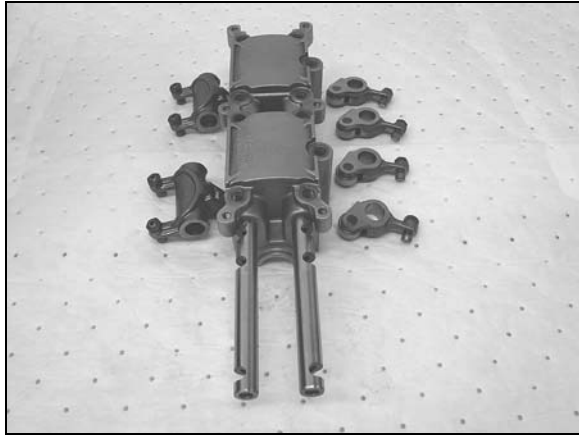

3. Inspect each rocker arm roller. Roller surface should be smooth and radial movement should be minimal. Roll a smooth flat rod across the roller, applying firm downward pressure on roller while observing roller movement. Roller should turn smoothly without binding. Replace rocker arm if roller surface is damaged, or if roller does not turn smoothly.

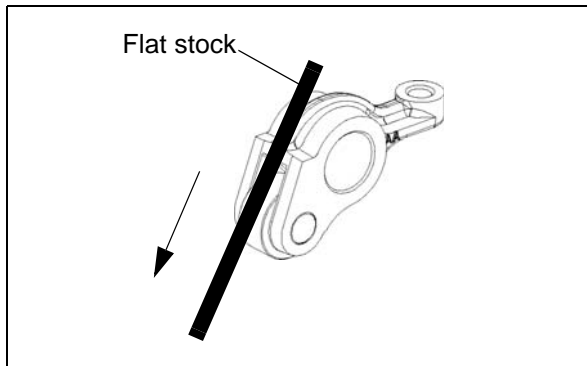

4. Measure I.D. of rocker arms and O.D. of rocker arm shafts. Measure shaft bore in cam carrier. Compare to specifications (See "Engine Specifications - EH085OLE-011" on page 5.5).

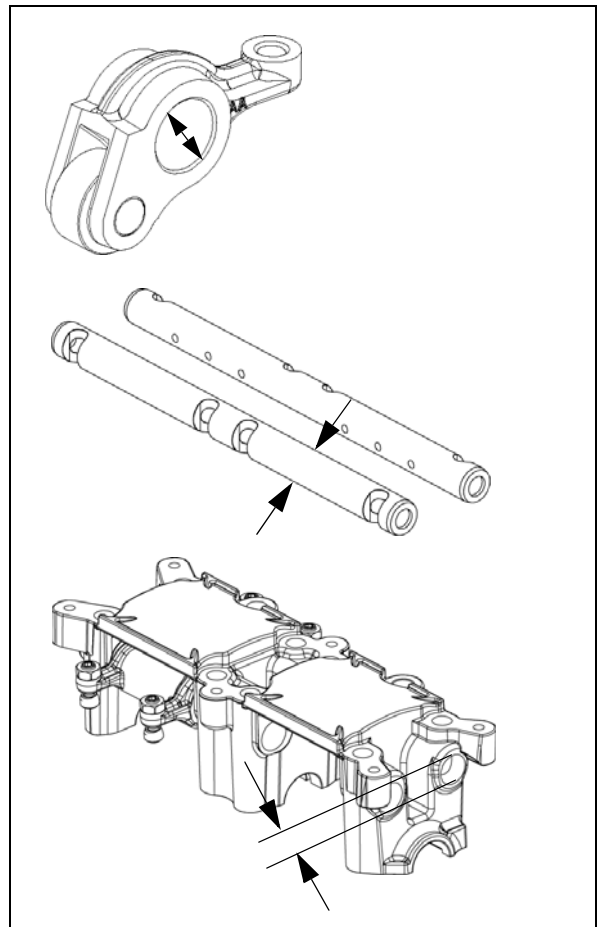

ENGINE

Camshaft / Camshaft Bore Inspection

1. After camshaft carrier is removed, lift camshaft from cylinder head. Inspect all main journals and cam lobes as described below and compare to specifications (See "Engine Specifications - EH085OLE-011" on page 5.5). Replace if worn beyond service limit or if any surface is pitted or damaged.
2. Measure all cam lobe heights from base circle to highest point on lobe.

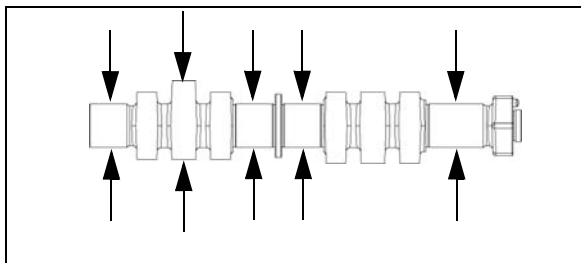

3. Temporarily install camshaft carrier as shown below to measure the camshaft bore. Replace cylinder head if worn.

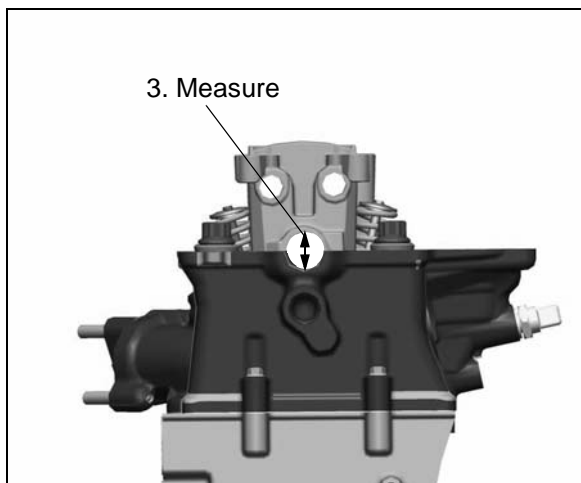
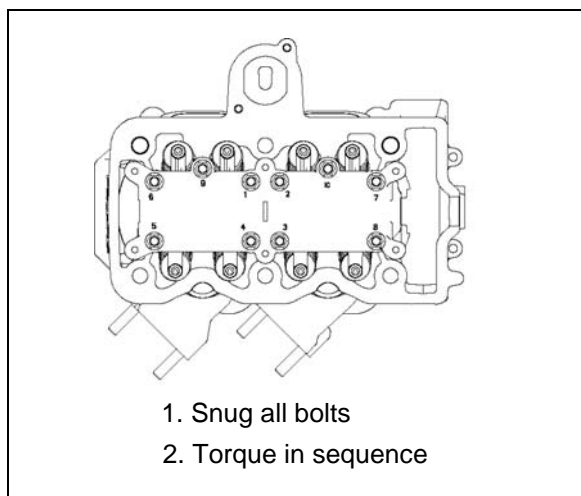

Cylinder Head Removal

1. Loosen two outer bolts (A), then loosen all head bolts (B) evenly, 1/8 turn at a time following the pattern below (6, 5, etc.) until all are loose. Remove all bolts, cylinder head, and gasket.

NOTE: Head can be removed from cylinder / crankcase without removing cam carrier (C) but the center two cylinder head bolts cannot be removed from the head unless carrier is removed.

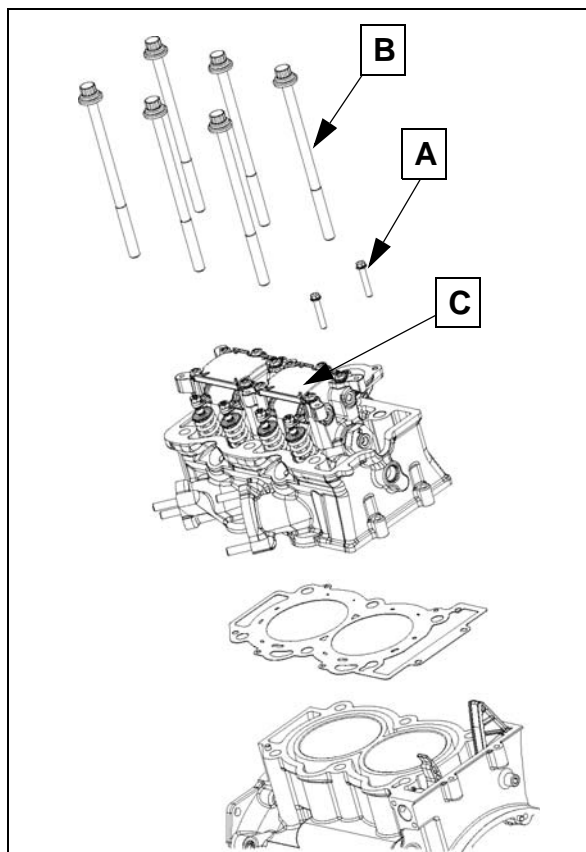

Cylinder Head Cleaning

Thoroughly clean cylinder head surface to remove all traces of gasket material and carbon.

NOTICE

Use care not to damage gasket sealing surface. All gasket surfaces must be clean, dry, and free of any oil or grease upon assembly. Clean sealing surfaces with rubbing alcohol, electrical contact cleaner or a brake cleaner that does not leave a solvent residue. Do not touch sealing surfaces of the new head gasket.

Cylinder Head Warp Inspection

1. Lay a straight edge (A) across surface of cylinder head at several different points and measure warp by inserting a feeler gauge between the straight edge and the cylinder head surface. If warp exceeds the service limit, replace the cylinder head.

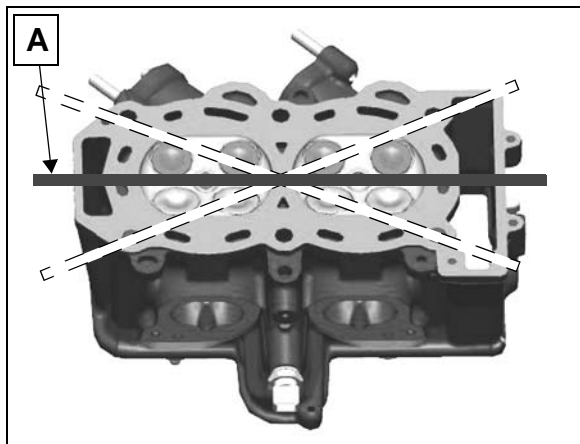

= In. / mm.

Cylinder Head Warp Limit:
.004" (.10 mm) max

Cylinder Head Disassembly

⚠ WARNING

Wear eye protection when removing and installing valve springs.

NOTE: Keep mated parts together for assembly. It is important to put cylinder head parts back in the same location. Mark parts or place them in a rack as you remove them.

Valve Spring Compressor: PV-1253 (or PV-4019 with adapter PV-43513-A)

1. Compress valve spring and remove split keepers (B).
2. Remove compressor, then remove top retainer, spring, and seal (C). Discard seals. Repeat for all remaining valves.
3. Clean combustion chamber and head gasket surface.

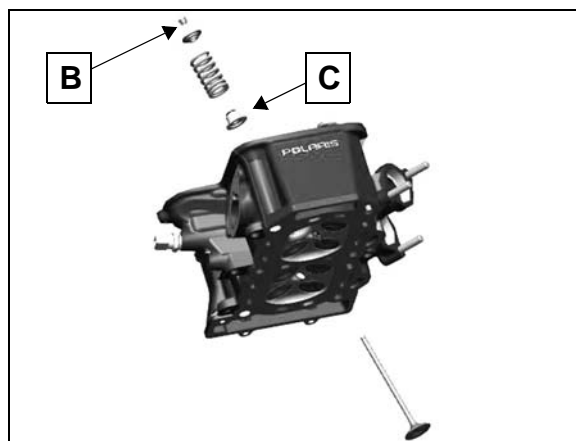

4. Measure free length of each spring with a Vernier caliper and compare to specification.

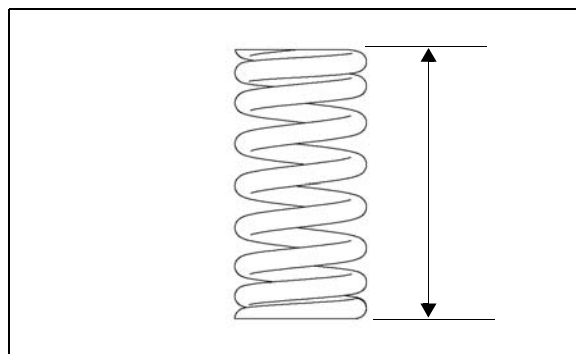

= In. / mm.

Valve Spring Free Length:
Std: 1.861" (47.26 mm)

ENGINE

Valve Inspection

1. Remove all carbon from valves with a soft wire wheel or brush.
2. Check valve face for runout, pitting, and burnt spots. To check for bent valve stems, mount valve in a drill or use "V" blocks and a dial indicator.

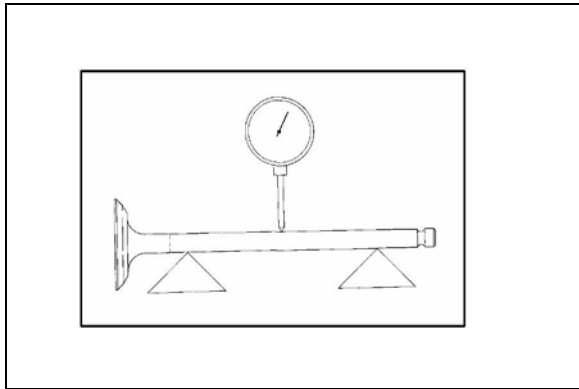

3. Check end of valve stem for flaring, pitting, wear or damage.

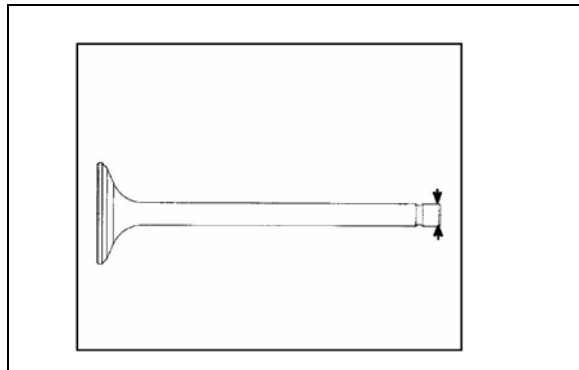

4. Inspect split keeper groove for wear or flaring of the keeper seat area.

NOTE: The valves can be re-faced or end ground, if necessary. They must be replaced if extensively worn, burnt, bent, or damaged.

5. Measure diameter of valve stem with a micrometer in three places, then rotate 90 degrees and measure again (six measurements total). Compare to specifications.

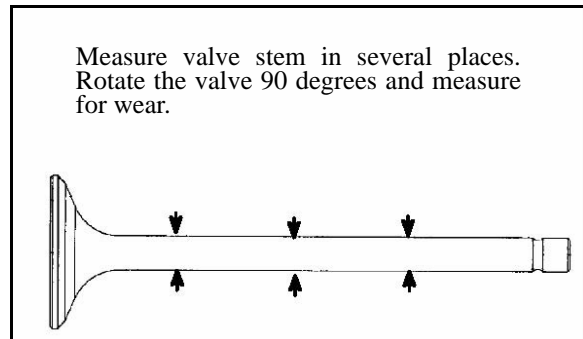

Valve Stem Diameter:
Intake: 0.2356" + 0.00039"
(5.985 + 0.01 mm)
Exhaust: 0.2351" + 0.00039"
(5.972 + 0.01 mm)

6. Measure valve guide inside diameter at the top middle and end of the guide using a small hole gauge and a micrometer. Measure in two directions.

Valve Guide I.D.:
0.23672" + 0.000295"
(6.0617 + 0.0075 mm)

7. Subtract valve stem measurement from the valve guide measurement to obtain stem to guide clearance. NOTE: The valve guides cannot be replaced. Be sure to measure each guide and valve combination individually.

Combustion Chamber

1. Clean all accumulated carbon deposits from combustion chamber and valve seat area.

NOTE: Carbon Clean Fuel Treatment (2871326) can be used to help remove carbon deposits.

IMPORTANT: Do not use a metal scraper, a coarse wire brush, or abrasive cleaners to clean the cylinder head. Damage may result.

2. Visually inspect cylinder head gasket surface and combustion chamber for cracks or damage. Pay close attention to the areas around spark plug and valve seats.

Valve Guide Removal / Installation

1. Support cylinder head and place valve guide remover into valve guide from the combustion chamber side.
2. Drive or press old valve guides out of cylinder head.

CAUTION

Replacement of valve guides requires an oven, special equipment and experience to do the job correctly. If you are unsure of your ability to do the repair professionally it is best to sublet the labor to a competent machinist. Valve seat reconditioning is required when valve guides are replaced.

CAUTION

The cylinder head can be easily damaged if the procedure is done carelessly.

3. Apply 90 weight oil to outside of new valve guides.

4. Drive or press new guides from camshaft side of head to proper installed height. Note difference between intake and exhaust guide height below.

Intake Valve Guide Height: 8.93 - 9.43 mm

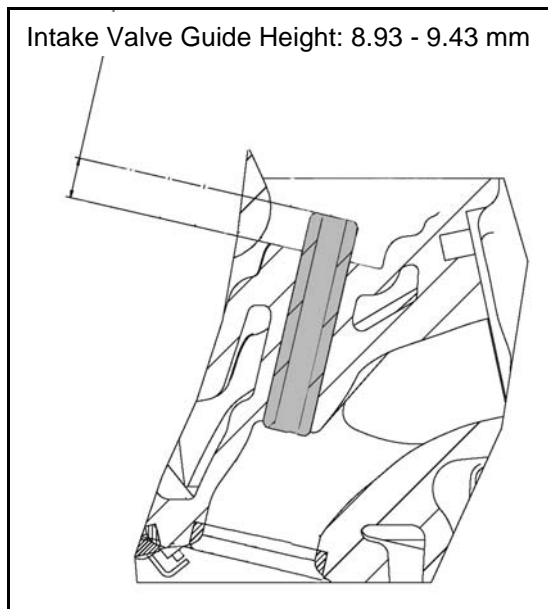

Exhaust Valve Guide Height: 6.75 - 7.25 mm

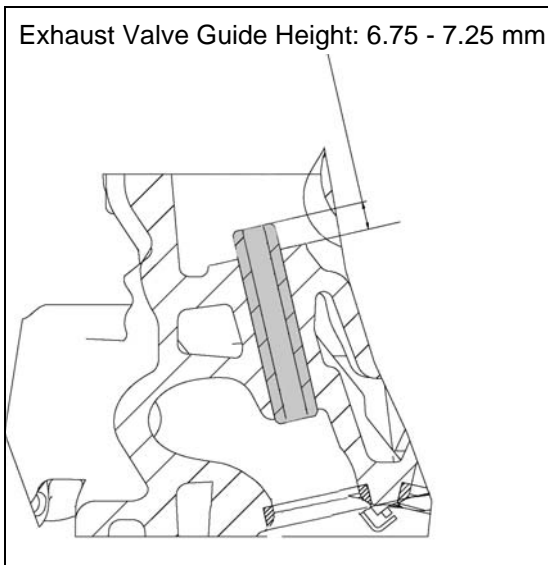

5. Ream or hone new valve guides to size to obtain specified stem-to-guide clearance. Ream from combustion chamber side of head.

CAUTION

Do not tilt the reamer while reaming the guide. Always rotate the reamer in a clockwise direction.

6. Clean cylinder head thoroughly with clean solvent.
7. Inspect valve seats and recondition if necessary.

ENGINE

Valve Seat Reconditioning

Valve seat reconditioning should be performed by a technician proficient in cylinder head reconditioning techniques. Reconditioning techniques vary, so follow the instructions provided by the valve reconditioning equipment manufacturer. Do not grind seats more than necessary to provide proper seat surface, width, and contact point on valve face.

Valve Seat Inspection

Inspect valve seat in cylinder head for pitting, burnt spots, roughness, and uneven surface. If any of the above conditions exist, the valve seat must be reconditioned. If the valve seat is cracked the cylinder head must be replaced.

Valve seat width and point of contact on the valve face is very important for proper sealing. The valve must contact the valve seat over the entire circumference of the seat, and the seat must be the proper width all the way around. If the seat is uneven, compression leakage will result. If the seat is too wide, seat pressure is reduced, causing carbon accumulation and possible compression loss. If the seat is too narrow, heat transfer from valve to seat is reduced. The valve may overheat and warp, resulting in burnt valves.

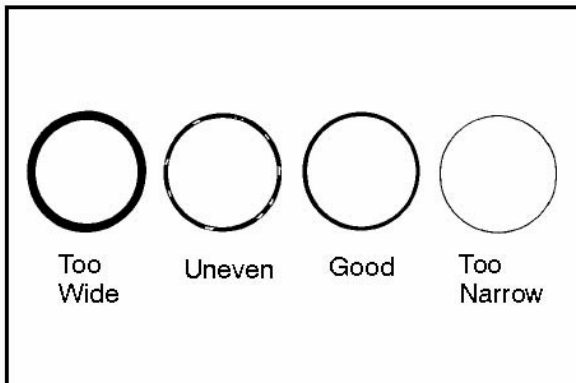

1. Install pilot into valve guide.
2. Apply cutting oil to valve seat and cutter.
3. Place 46° cutter on the pilot and make a light cut.
4. Inspect the cut area of the seat:

* If the contact area is less than 75% of the circumference of the seat, rotate the pilot 180° and make another light cut.

* If the cutter now contacts the uncut portion of the seat, check the pilot. Look for burrs, nicks, or runout. If the pilot is bent it must be replaced.

* If the contact area of the cutter is in the same place, the valve guide is distorted from improper installation

* If the contact area of the initial cut is greater than 75%, continue to cut the seat until all pits are removed and a new seat surface is evident. **NOTE:** Remove only the amount of material necessary to repair the seat surface.

5. To check the contact area of the seat on the valve face, apply a thin coating of Prussian Blue™ paste to the valve seat. If using an interference angle (46°) apply black permanent marker to the entire valve face (A).

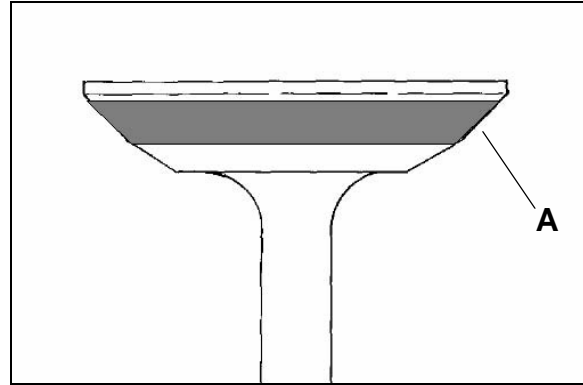

6. Insert valve into guide and tap valve lightly into place a few times.
7. Remove valve and check where the Prussian Blue™ indicates seat contact on the valve face. The valve seat should contact the middle of the valve face or slightly above, and must be the proper width.

* If the indicated seat contact is at the top edge of the valve face and contacts the margin area (B) it is too high on the valve face. Use the 30° cutter to lower the valve seat.

* If too low, use the 60° cutter to raise the seat. When contact area is centered on the valve face, measure seat width.

* If the seat is too wide or uneven, use both top and bottom cutters to narrow the seat.

* If the seat is too narrow, widen using the 45° cutter and re-check contact point on the valve face and seat width after each cut.

NOTE: When using an interference angle, the seat contact point on the valve will be very narrow, and is a normal condition. Look for an even and continuous contact point all the way around the valve face (A).

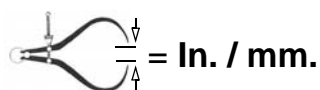
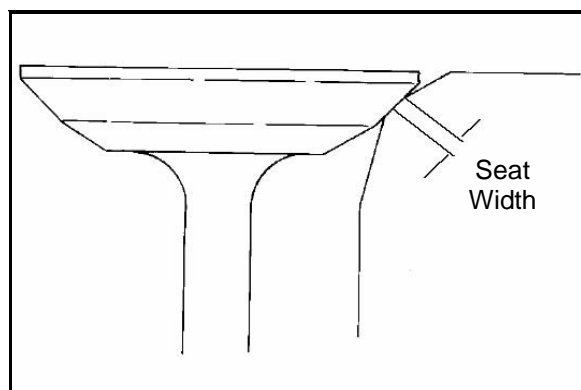
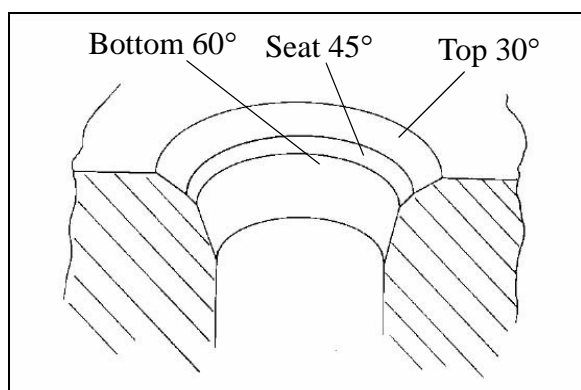
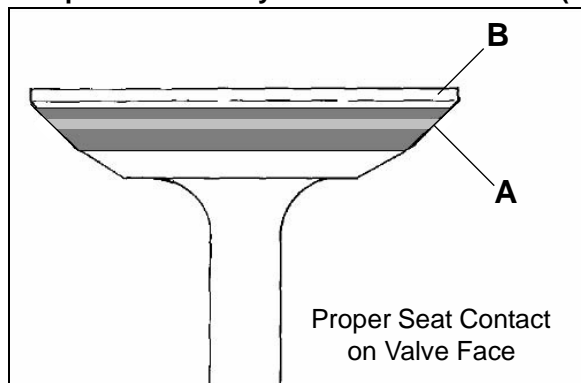

Valve Seat Width:
Intake Std: .028" (.7 mm)
Limit: .055" (1.4 mm)
Exhaust Std: .0391 (1.0 mm)
Limit: .071" (1.8 mm)

8. Clean all filings from the area with hot soapy water. Rinse and dry with compressed air.
9. Lubricate the valve guides with clean engine oil, and apply oil or water based lapping compound to the face of the valve.

NOTE: Lapping not required if an interference angle reconditioning method is used.

10. Insert the valve into its respective guide and lap using a lapping tool or a section of fuel line connected to the valve stem.
11. Rotate the valve rapidly back and forth until the cut sounds smooth. Lift the valve slightly off of the seat, rotate 1/4 turn, and repeat the lapping process. Do this four to five times until the valve is fully seated, and repeat process for the other valve(s).
12. Thoroughly clean cylinder head and valves.

ENGINE

Cylinder Head Assembly

NOTE: Assemble valves one at a time to maintain proper order.

1. Apply engine oil to valve guides and seats.
2. Coat valve stem with Premium Starter Grease (2871460).
3. Install valve in guide.
4. Valve seals should be installed after the valves are in the head to avoid valve seal damage. Install NEW valve seals on valve guides carefully with a rotating motion.
5. Dip valve spring and retainer in clean engine oil.
6. Install spring with tight wind facing DOWN (toward head).
7. Place top retainer on spring.
8. Compress spring.
9. Install split keepers with gap even on both sides.

NOTE: To prevent damage to the valve seals, do not compress the valve spring more than necessary to install the keepers. A small magnet can be used to aid installation.

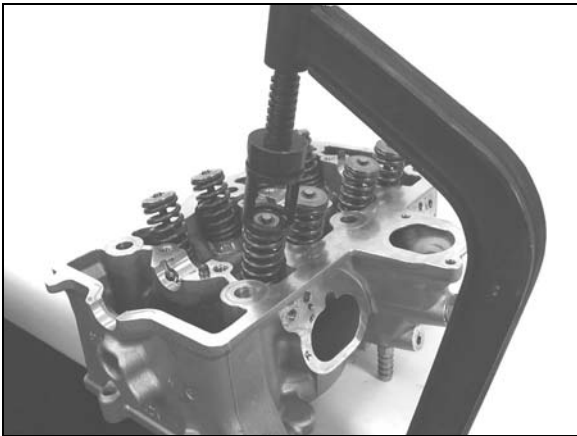

10. Repeat procedure for remaining valves. When all valves are installed, tap lightly with soft faced hammer on the end of the valves to seat the split keepers.

WARNING

Do not tap on the top retainer or split keepers could dislodge, causing serious injury. Tap only on the end of the valve stem.

Valve Sealing Test

1. Clean and dry the combustion chamber area (A).
2. Pour a small amount of clean solvent into each intake port (B) and check for leakage around the valves. The valve seats should hold fluid with no seepage.
3. Repeat for exhaust valves by pouring fluid into each exhaust port (C).

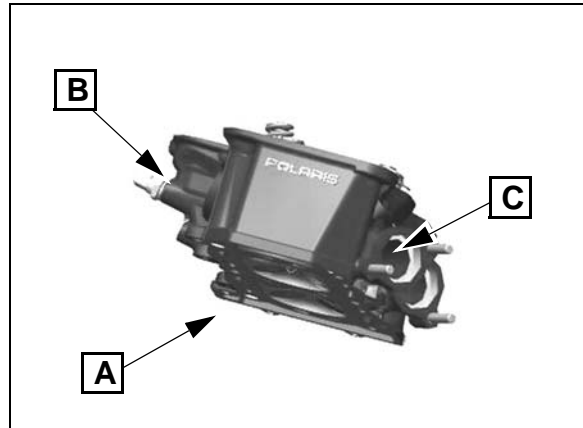

Cylinder Head Installation

1. Prepare cylinder head gasket sealing surfaces by cleaning thoroughly to remove all residue. The head gasket must be installed clean and dry, free from oil or grease.

NOTE: Do not touch sealing surfaces of gasket.

2. Reinstall (2) head alignment pins in upper crankcase.
3. Install cam chain tensioner blade in upper crankcase. Install a new O-ring on pivot bolt and lubricate with engine oil. Torque bolt (A) to specification.

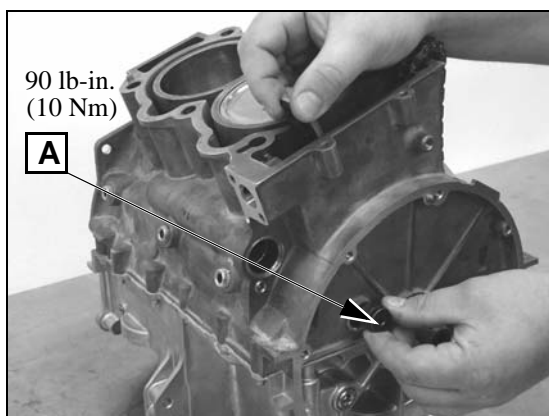

4. Lift cam chain and install chain guide.

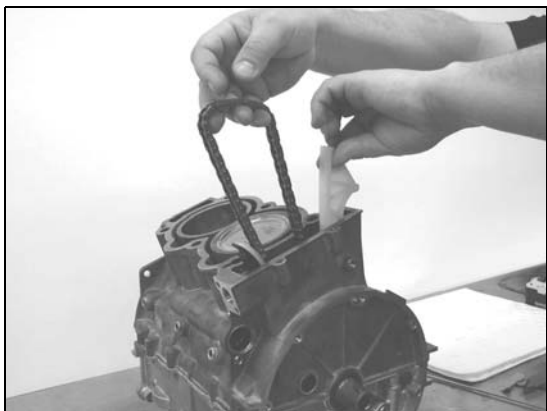

5. Be sure tabs (B) are engaged in slots. Secure cam chain with a wire so it will not fall into crankcase.

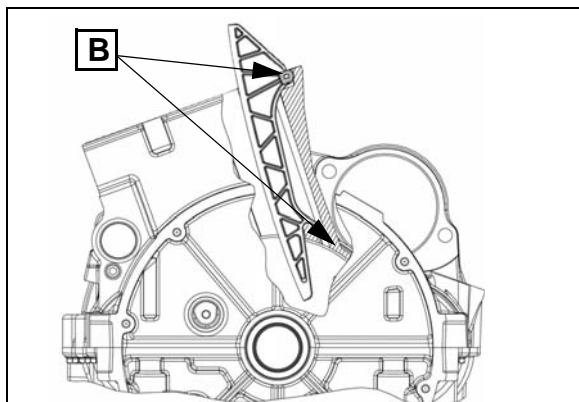

6. Thread cam chain through a new head gasket and install gasket, locating it on the alignment pins.
7. Set cylinder head in place on alignment pins. Apply engine oil to threads and flange of the (6) main cylinder head bolts.

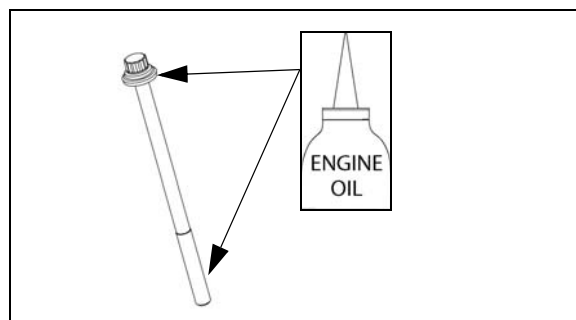

8. Tighten main head bolts finger tight, then install the two 6mm outer bolts.

CYLINDER HEAD TORQUE PROCEDURE

- Tighten (6) main head bolts snug.
- Torque (6) main head bolts in sequence shown below to 43.5 lb-ft. (59 Nm).
- Tighten each main head bolt an additional 90 degrees (1/4 turn) following torque sequence.
- Install (2) M6 outer head bolts (C) and torque to specification.

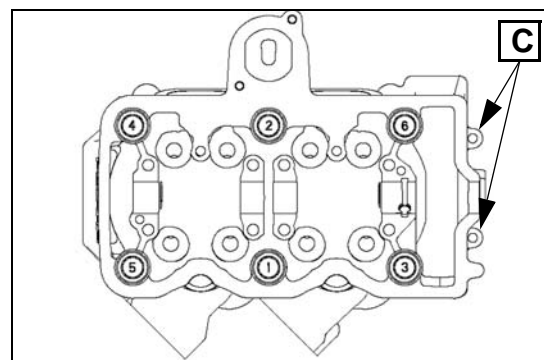

ENGINE

Camshaft / Carrier Assembly

1. Lubricate all camshaft lobes and bearing journal surfaces with Premium Starter Grease (PN 2871460).

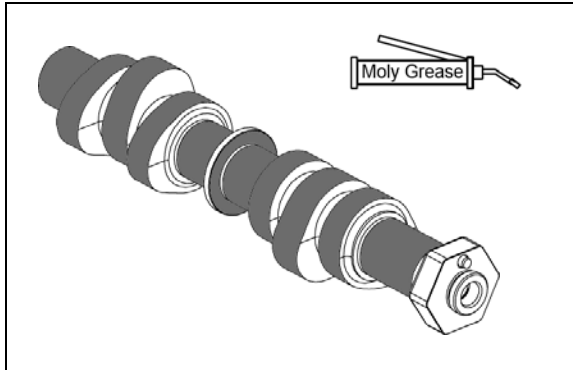

2. Place camshaft in cylinder head.
3. Lubricate rocker arms, rollers, and shafts with engine oil. Lay out in proper location as marked upon disassembly.
4. Assemble camshaft carrier with rocker arms and shafts. Slots (A) must face outward of carrier to allow bolt installation and to properly orient the oiler holes in shafts.

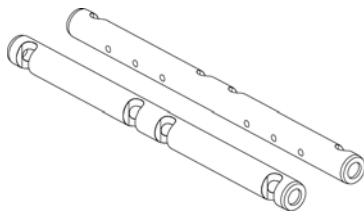
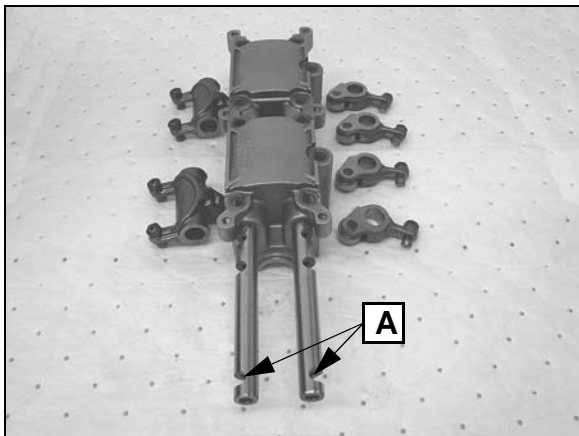

Camshaft / Camshaft Carrier Installation

1. Loosen all valve adjuster lock nuts.
2. Turn adjuster screws out (counterclockwise) until they *lightly* seat against rocker arm.

NOTE: DO NOT force screws against rocker arm. The adjuster pivot ball may be damaged if forced.

3. Rotate crankshaft in direction of rotation until Top Dead Center mark (B) on flywheel is aligned with crankcase parting line (C). This is TDC for MAG side cylinder.

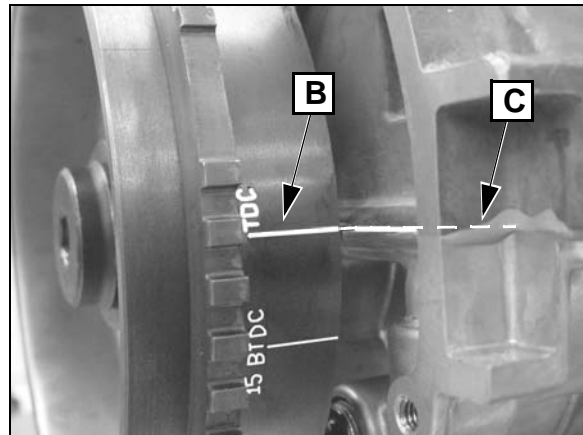

4. Rotate camshaft until pin (D) is in 10:00 position.

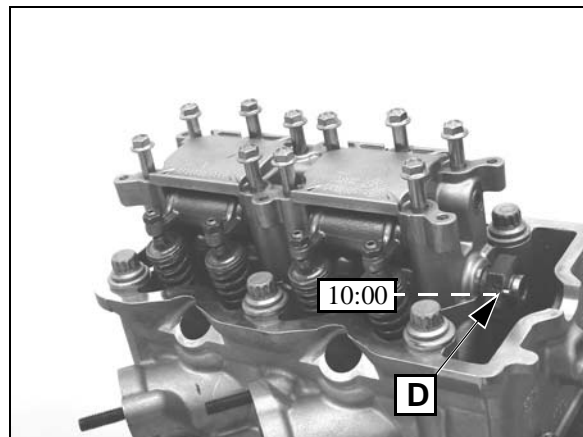

5. Install camshaft carrier onto camshaft and install all carrier bolts snug. Torque in two steps following sequence shown.

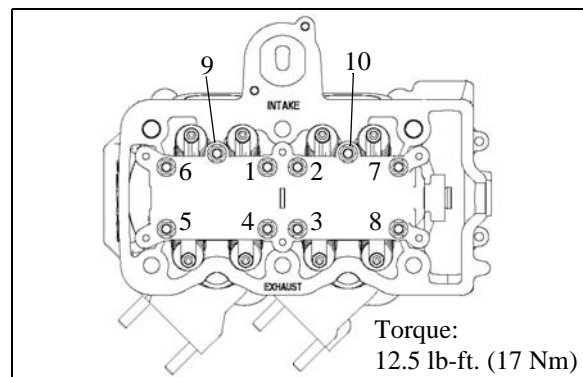

Camshaft Timing

Also refer to Camshaft Timing Quick Reference (page 5.39).

1. Rotate camshaft clockwise until pin (A) is facing UP (use a wrench across the flats on the sprocket end).

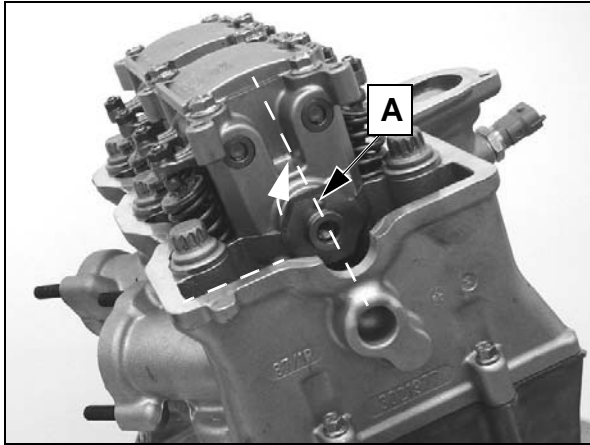

2. Verify TDC mark on flywheel is aligned with crankcase parting line.

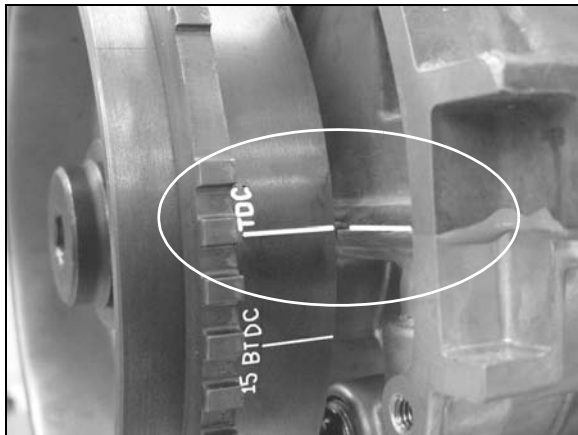

3. Pull cam chain upward, making sure it is engage with the drive sprocket on the crankshaft.
4. Place the sprocket (with marks facing out) on the chain and engage all teeth.

5. Align two sprocket marks with valve cover gasket surface.
6. Slide sprocket onto camshaft, aligning slot in sprocket with pin.
7. Screw in the sprocket bolt finger tight. Sprocket bolt must be tightened fully after cam chain tensioner is installed.



8. Verify flywheel TDC mark is still aligned (be sure the crankshaft has not rotated from TDC) and that sprocket marks are aligned with gasket surface (note that cam chain tensioner installation may change the alignment slightly).
9. If marks are not aligned, remove sprocket bolt and correct alignment.
10. Proceed to Cam Chain Tensioner Installation (page 5.38).

ENGINE

Cam Chain Tensioner Installation

1. Lubricate tensioner plunger and install in tensioner bore with check valve end of plunger (B) facing OUT (toward cap plate).

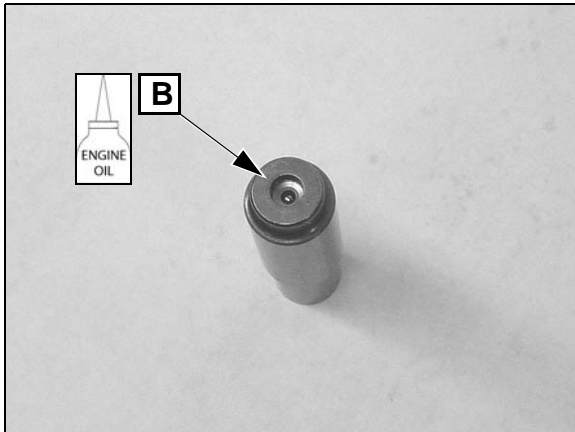

2. Start outer tensioner bolt through cap plate and new gasket. Start bolt about 5 threads into outer hole.

NOTE: "Top" mark on tensioner cap plate faces UP.

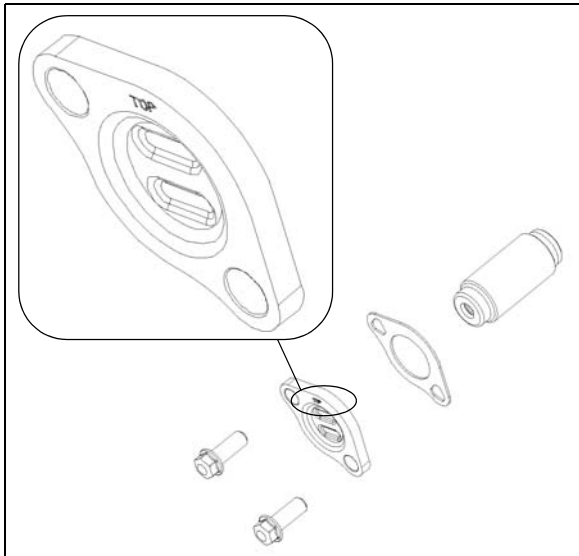

3. Push tensioner plunger in and hold.

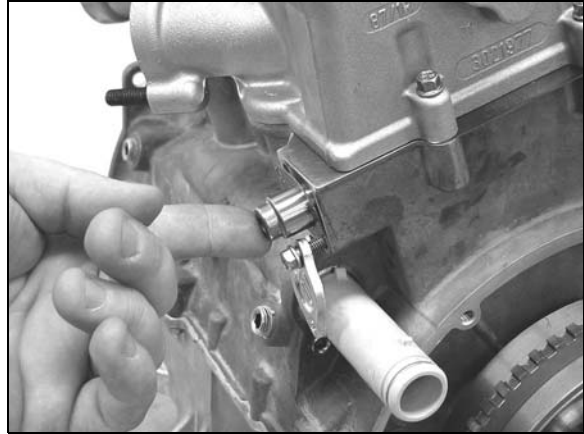

4. Rotate plate and gasket into position and start the inner bolt.
5. Slowly draw bolts evenly until snug.

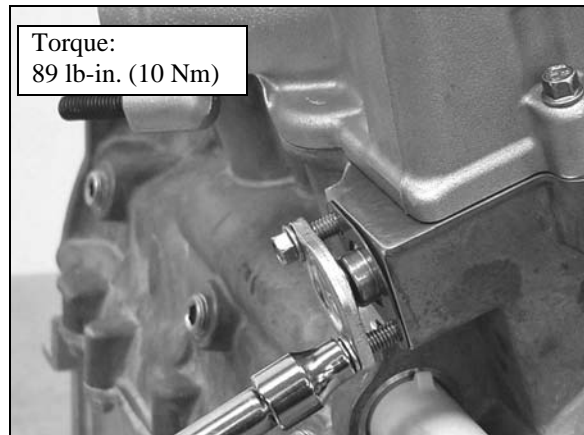

6. Torque tensioner cap bolts.
7. Rotate crankshaft through two revolutions and verify camshaft timing is correct.
8. Torque camshaft sprocket bolt.

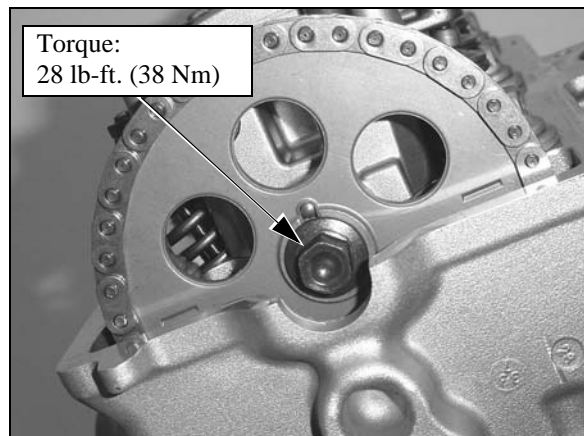

9. Adjust valve clearance on all valves (refer to Chapter 2 "Maintenance").

Camshaft Timing - Quick Reference

View With Stator Cover Removed

View Through Timing Plug

Crankcase Parting Line

TDC Mark

Flywheel

Pin facing UP

Sprocket marks aligned with surface of head

Crankshaft / Camshaft Center line

Flywheel key UP (in line with crankshaft / camshaft centerline) or if flywheel is installed use TDC mark.

Tensioner Installed

Crankshaft at TDC, MAG Cylinder

IMPORTANT!
Valve and / or piston damage can occur if engine is rotated with camshaft incorrectly timed.

The diagrams show the following details:
1. **View With Stator Cover Removed:** Shows the stator cover with a 'TDC' mark and a '15 BTDC' mark. A 'Crankcase Parting Line' is indicated.
2. **View Through Timing Plug:** Shows the flywheel with a 'TDC' mark. The 'Crankcase Parting Line' and 'TDC Mark' are also labeled.
3. **Engine Assembly View:** Shows the engine head and crankshaft. Labels include 'Pin facing UP', 'Sprocket marks aligned with surface of head', 'Crankshaft / Camshaft Center line', and 'Flywheel key UP (in line with crankshaft / camshaft centerline) or if flywheel is installed use TDC mark.'
4. **Tensioner Installed:** Shows the tensioner installed on the crankshaft. The caption below is 'Crankshaft at TDC, MAG Cylinder'.

ENGINE

Crankcase Disassembly

⚠ CAUTION

The rotor contains powerful magnets. Use caution when removing and installing the stator cover. **DO NOT** place fingers between cover and crankcase at any time during the removal / installation process or injury could result.

NOTICE

Do not attempt to lift the upper crankcase / cylinder from the lower crankcase for piston / ring access without first removing the lower crankcase and connecting rod caps from the crankshaft. Pistons must be removed through the *top* of the cylinders with the connecting rod attached.

1. Remove cylinder head (beginning on page 5.26).
2. Remove all water pump cover screws (A) and stator cover screws (B), noting location of wire clamp (C).
NOTE: Water pump cover removal is not required unless water pump or cover gasket service will be performed. Water pump service is described on page 5.59.

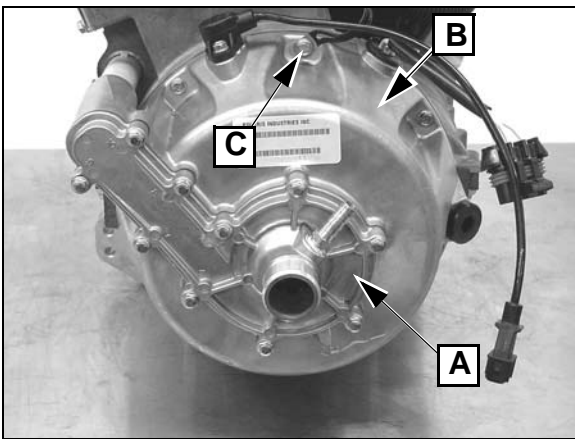

3. Remove starter gear / drive coupler bolts, plate, and gear.

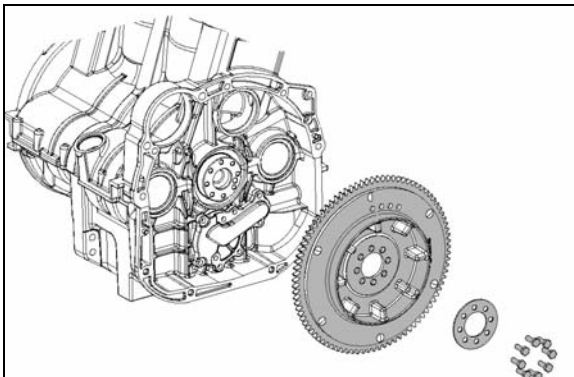

4. Remove water pump drive coupler damper (D).

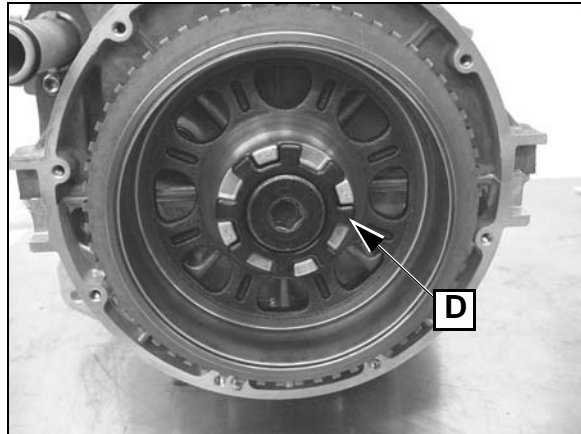

5. Use the end of Flywheel Puller PA-49316 to remove coupler nut.

NOTE: The water pump drive coupler nut has a LEFT HAND THREAD. Turn CLOCKWISE to remove.

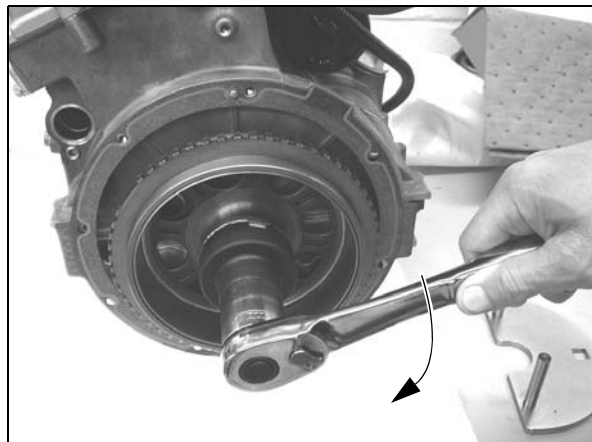

6. Hold flywheel with Crankshaft Holding Tool PA-49318, and remove flywheel bolt.

NOTE: The flywheel bolt has a LEFT HAND THREAD. Turn CLOCKWISE to remove.

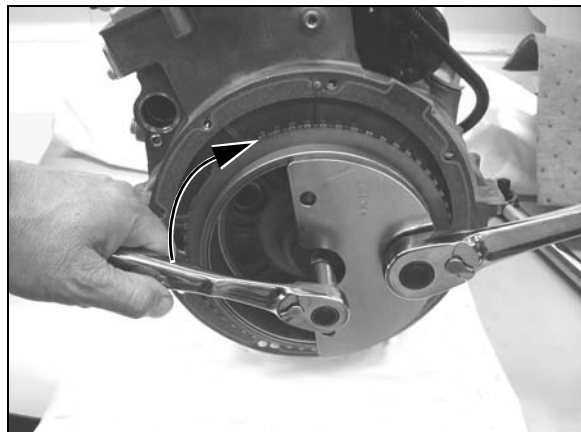

7. Fully install Flywheel Puller PA-49316 on threads of flywheel (left hand thread - turn flywheel puller *COUNTERCLOCKWISE* to install on flywheel).
8. Hold puller body (A) and tighten center bolt (B) to remove flywheel.

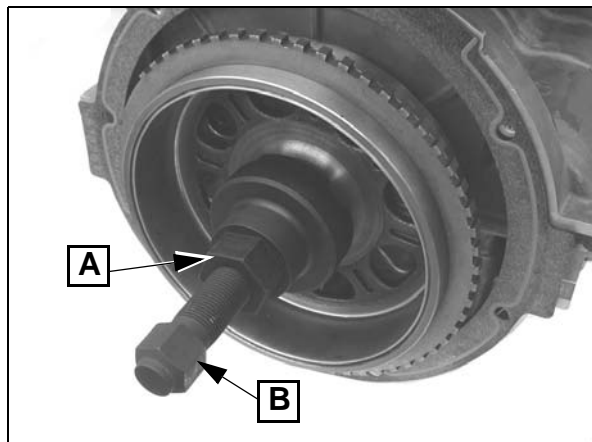

9. Loosen (12) outer crankcase bolts (C) evenly 1/2 turn, then loosen (2) longer case bolts (D), then the (6) main crankcase bolts (E). Remove all.

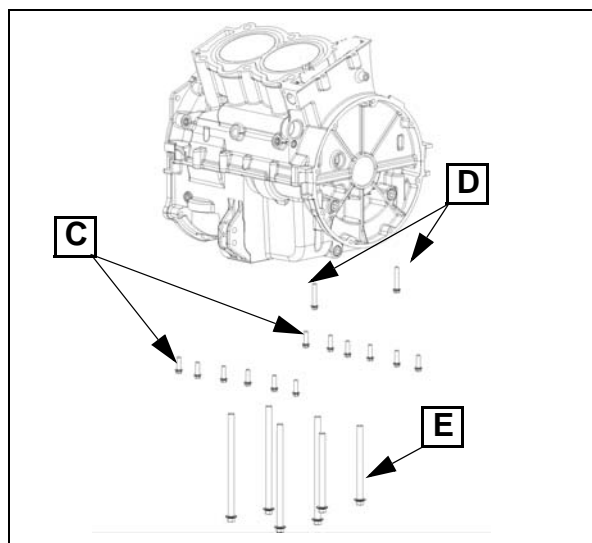

10. Tap lower crankcase in reinforced areas with a soft faced hammer to loosen, then lift straight upward to remove.

Crankcase (Lower) / Oil Pump Disassembly

1. Remove oil pump cover plate screws. Note location of two longer (M6x20) screws for assembly. These screws secure the pump.
2. Remove three baffle plate screws (A) and plate.

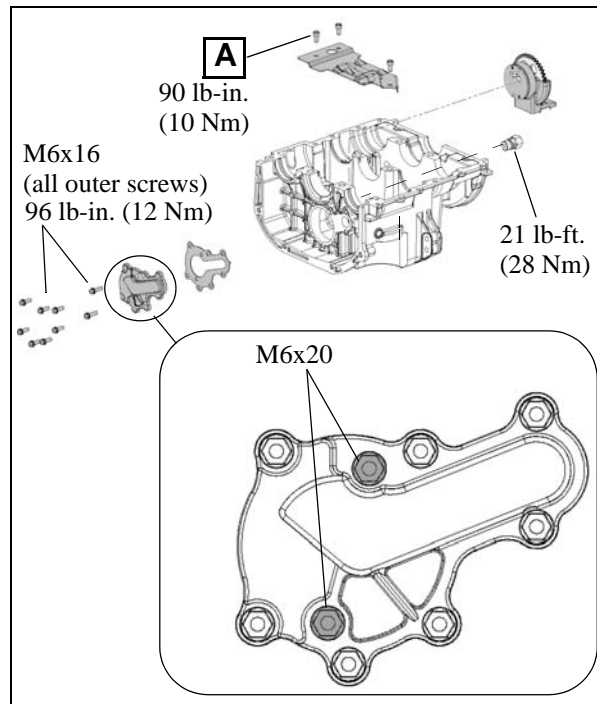

3. Slide pump off mounting boss in crankcase.
4. Visually inspect pump rotors and drive gear for damage or debris.

NOTE: Replace oil pump as an assembly and pressure relief valve if debris has entered pump or if pump damage is evident.

5. Rotate pump gear until rotors are positioned as shown below. Use a feeler gauge to measure tip clearance. **Clearance should not exceed 0.006" (.15mm).**

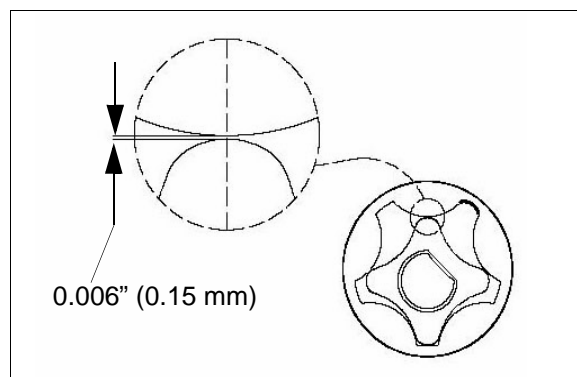

ENGINE

6. Measure pump rotor clearance to pump cover plate with a feeler gauge through the pump outlet window and compare to specification.
7. Measure shaft axial (end) free play and compare to specification.
8. Inspect inner rotor drive pin for wear or damage.
9. Remove oil pressure relief from crankcase. Replace if debris has entered, or if oil pressure was outside of specified range.

⊕ = T
20 ± 2 ft. lbs. (27 ± 3 Nm)

OIL PUMP DETAIL

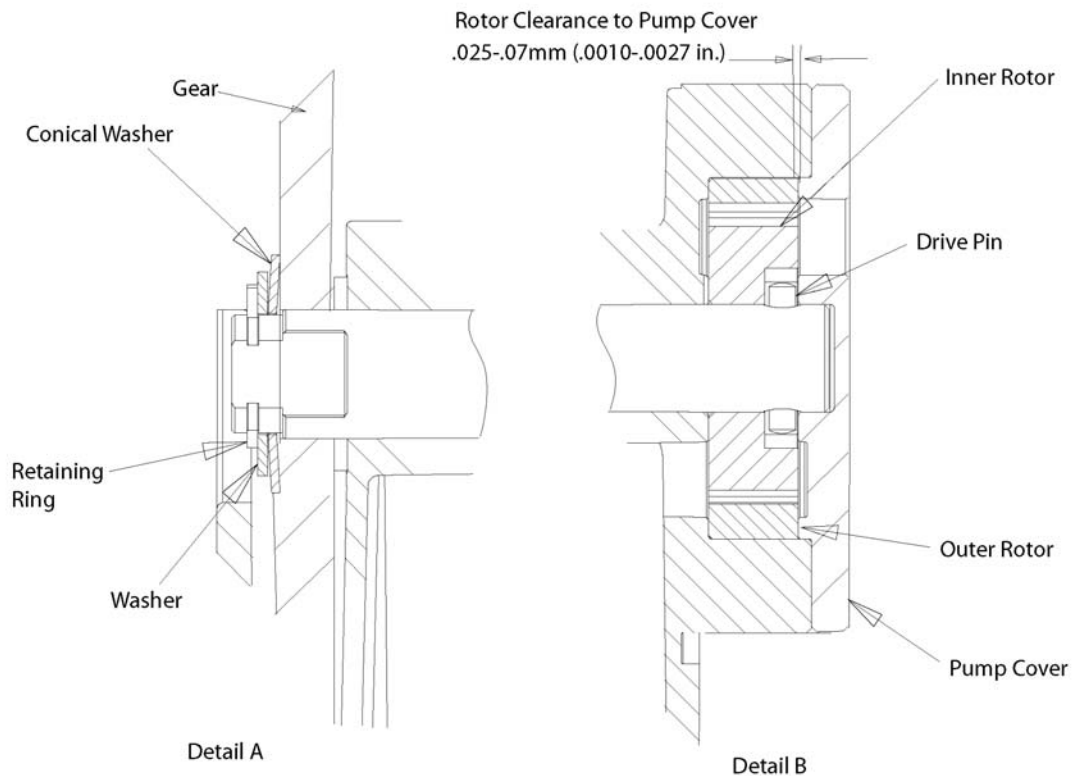
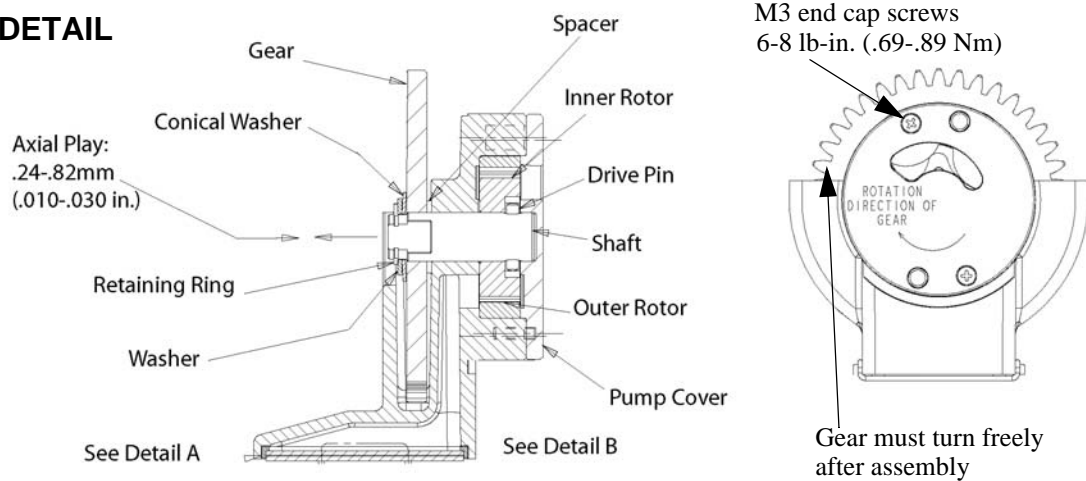

Crankcase Disassembly (Upper)

1. Remove the oil passage connecting tube (F) with O-rings.

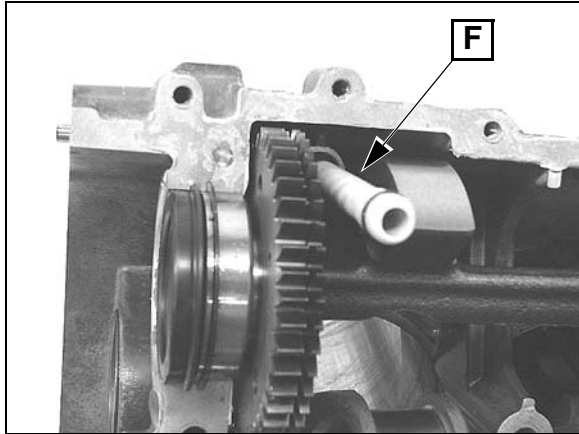

2. Note connecting rod and cap marks so they can be oriented properly and assembled in the same manner as matched sets on proper rod journal (G). New rods can be installed with marks to front or rear. Rods have no offset.

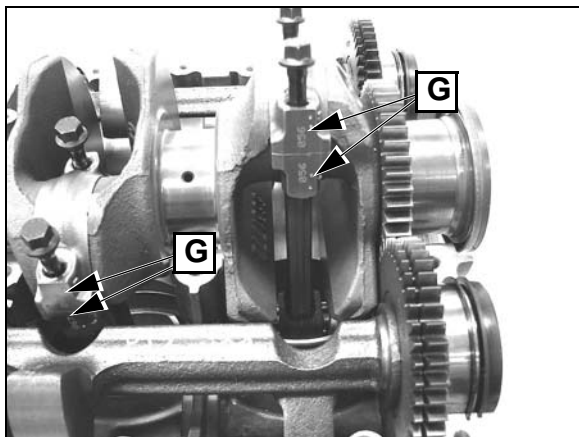

Piston / Connecting Rod Removal

1. Note orientation of piston with arrow (A) to MAG end of crankshaft.

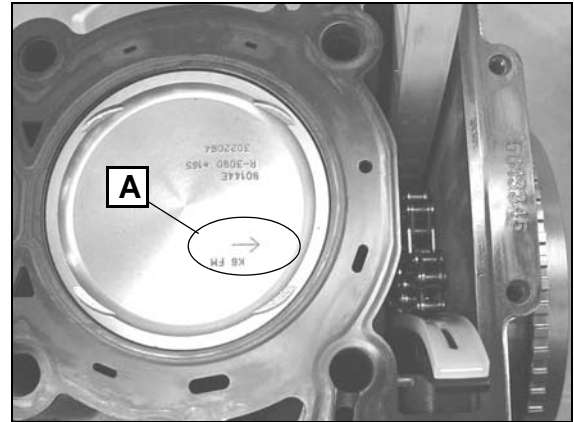

2. Push connecting rod / piston assembly out through top of cylinder bore of upper crankcase.

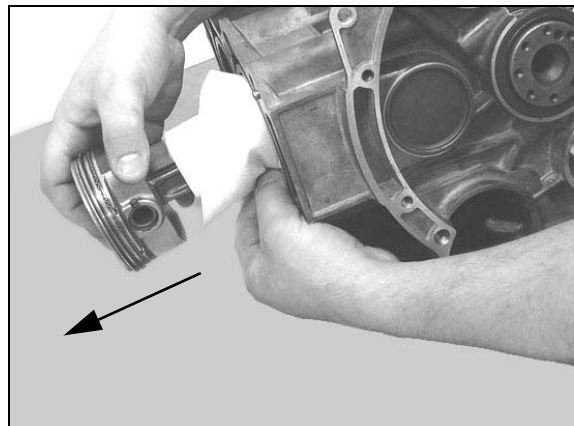

NOTE: If pistons are to be reused, mark them for assembly in same cylinder.

3. See "Piston / Piston Ring Inspection" on page 5.48

ENGINE

Counterbalance Shaft Removal / Inspection

1. Note timing marks on balance shaft drive gears and crankshaft drive gear. Shafts must be properly timed upon assembly.
2. Mark each shaft location for assembly (starter side or oil pipe side).
3. Lift both balance shafts from upper crankcase and remove end plugs.

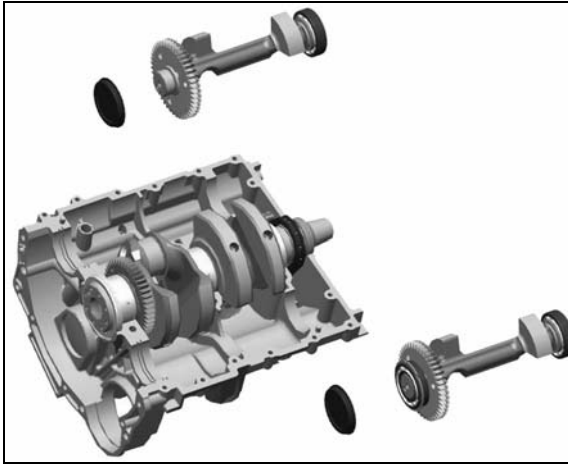

4. Inspect both counterbalance shaft bearings.

NOTE: Due to extremely close tolerances, counterbalance shaft bearings must be inspected visually, and by feel. Look for signs of discoloration, scoring, galling, or contamination from moisture or dirt. Turn bearings on shaft. Bearings should turn smoothly and quietly. The outer race should be firm with minimal side to side movement and no detectable up and down movement. Replace bearings if any of the above are present.

5. Inspect gear teeth for damage. Normal split gear alignment is approximately 1/2 tooth in the relaxed position as shown.



6. Hold main gear (A) and rotate split gear counterclockwise (viewed from gear end) to compress springs. Split gear should rotate and return freely and completely without binding.

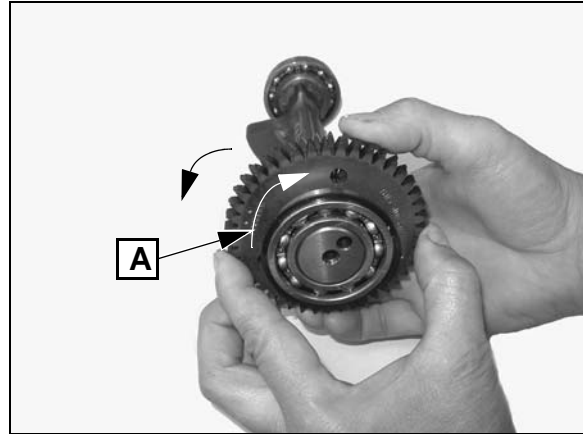

Counterbalance Split Gear Replacement

1. Set shaft upright in a press with gear fully supported on each side with a flat press plate. Select a suitable arbor (slightly smaller than the O.D. of the shaft), and press shaft out of bearing and then out of gear assembly.



NOTE: Do not attempt to press off the thrust washer with the split gear. The washer is positioned behind the alignment pin and can only be replaced if the pin is removed (see the following illustration).

2. Visually inspect thrust washer. Remove pin and replace washer if damaged or worn to less than 1.15 mm (.045 in.).

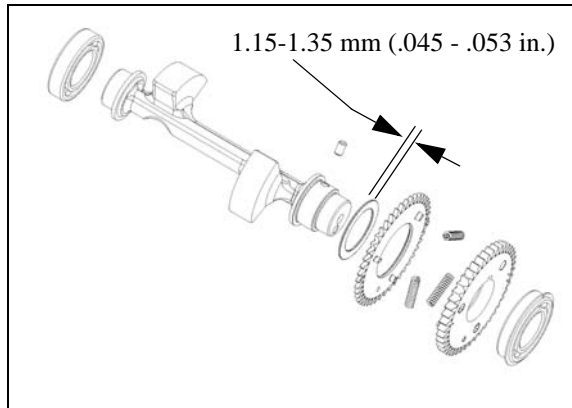

3. Lubricate and install (3) new springs (A) in new drive gear. Small holes (B) must be aligned upon assembly.
4. Place split gear on drive gear with tabs (B) of split gear toward springs of drive gear, and holes (C) aligned.

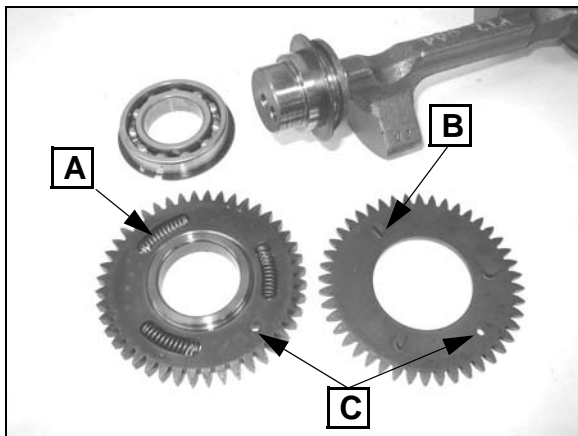

5. Hold gear assembly together. Turn over on workbench. Working through access holes (D), push back each spring until all three tabs of split gear are engaged and split gear seats to drive gear.

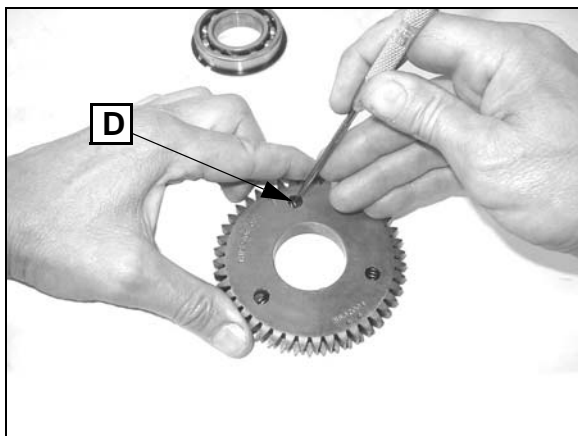

6. Lay gear assembly on press plate with split gear side UP.
7. Carefully align pin of balance shaft with slot in gear. Press shaft into gear assembly until seated against washer.



8. Lay new bearing (retaining ring side down) on open press plate so both inner and outer races are supported.
9. Press shaft assembly into bearing until seated.



ENGINE

Crankshaft / Cam Chain Removal

1. Remove crankshaft with cam chain and end seals.



Cam Chain / Sprocket Inspection

1. Cam chain should be replaced if damage is evident or if sprockets show visible signs of wear. Inspect drive and driven sprocket as shown below.

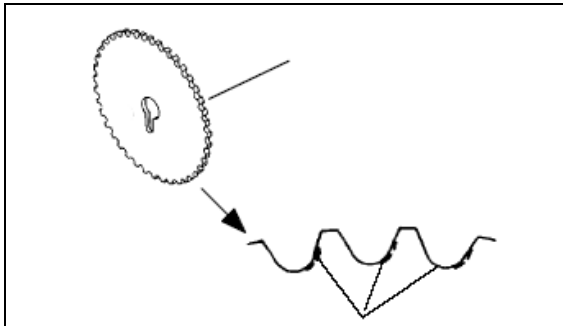

Crankcase Inspection (Lower)

1. Remove main bearing inserts from lower crankcase half. Replace the crankcase assembly if a bearing bore is galled or if bearing inserts have rotated in the case.

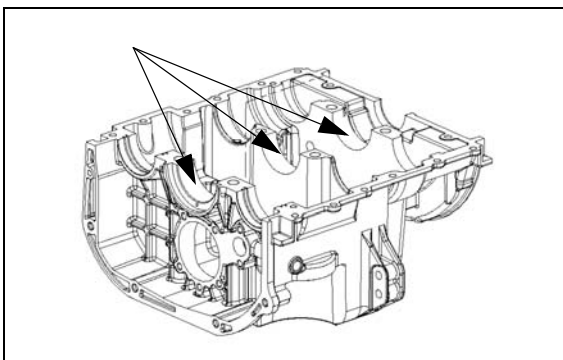

Crankshaft Inspection

1. Visually inspect surface of crankshaft main and connecting rod journals. Replace crankshaft if any journal is scratched or pitted.
2. Measure each main journal (A) and rod journal (B) in two locations, 90 degrees apart. Record measurements for bearing selection on page 5.48. Calculate the difference between the two measurements for each journal to determine concentricity (C). Replace crankshaft if any journal is worn below the minimum diameter specification or if journal out-of-round exceeds maximum specification.

A - Crankshaft Main Journal Diameter:
2.1642 - 2.1650 (54.970 - 54.990 mm)

C - Crankshaft Main Journal Concentricity:
< 0.00027" (0.007 mm) Out Of Round

B - Connecting Rod Journal Diameter:
1.7718 - 1.7726 " (45.005 - 45.025 mm)

C - Connecting Rod Journal Concentricity:
< 0.00027" (0.007 mm) Out Of Round

D - Maximum Runout:
.001 " (.025 mm)

3. Support crankshaft on V-blocks or on-centers in a crankshaft stand or lathe. Measure crankshaft runout (E) and replace if runout exceeds maximum listed above.

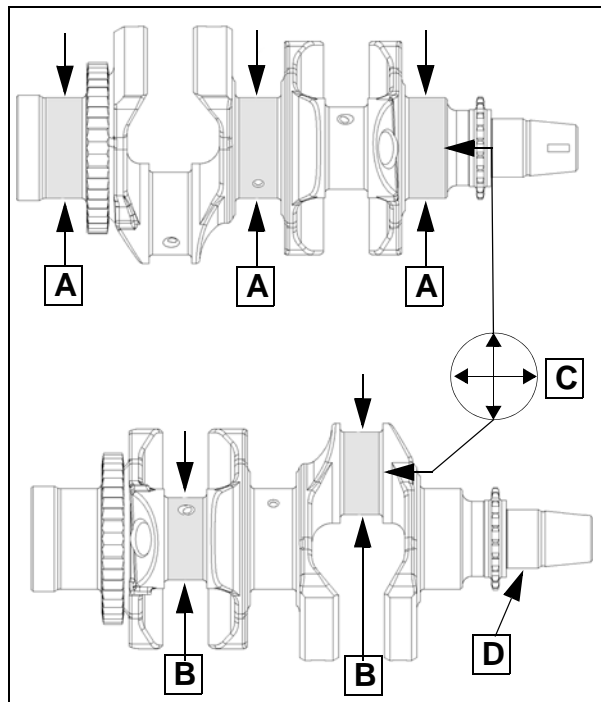

Connecting Rod Inspection

1. Secure connecting rod lightly in a soft jawed vise.
2. Note location of the piston circlip gap (A) at top.

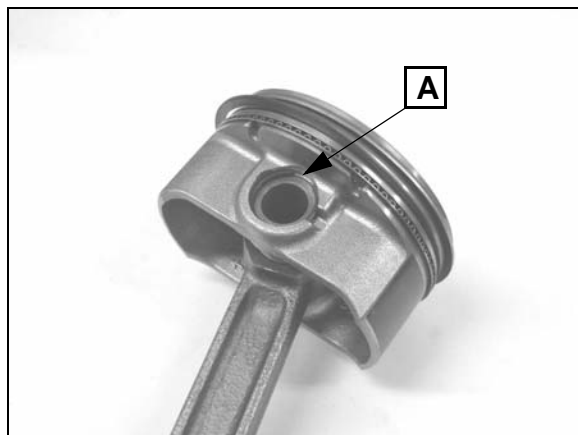

3. Remove piston circlip.
4. Push piston pin out of piston. If necessary, heat crown of piston slightly with a propane torch or heat gun.

NOTICE

Do not apply heat to piston rings or a loss of radial tension could result.

5. Measure piston pin O.D. in two directions and 3 locations on the length.

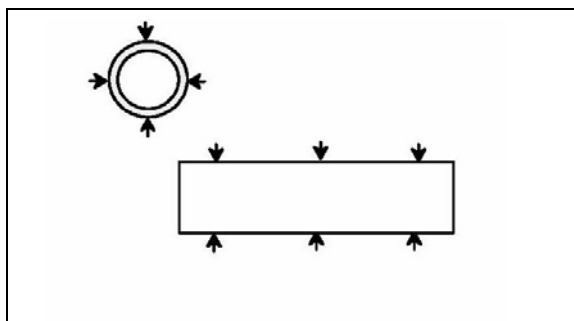

Piston Pin O.D. :
0.7873" ± .0001" (19.9975 ± .0025 mm)

6. Inspect small end and big end of connecting rod (and matching rod cap) for damage, galling of surface or pitting.

7. Measure small end I.D. in two directions as shown. Record measurements. Difference between measurements is concentricity. Compare to specifications.

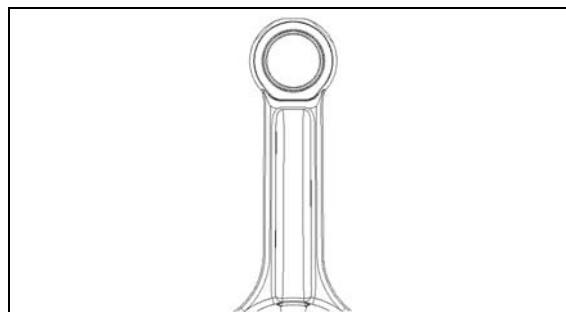

Connecting Rod (Small End) Diameter:
0.7886 + 0.0 / - .015" (20.03 + 0.0 / - .015 mm)

Connecting Rod (Small End) Concentricity:
< 0.00027" (0.007 mm) Out Of Round

8. Install matching rod cap on connecting rod (without bearings) and install bolts.
9. Tighten bolts snug, then torque to 24 lb-ft (33 Nm).
10. Using a dial bore gauge, measure big end I.D. in two directions shown. Record measurements. Difference between measurements is concentricity. Compare to specifications.
11. Select appropriate bearing insert (color) from table (page 5.48).

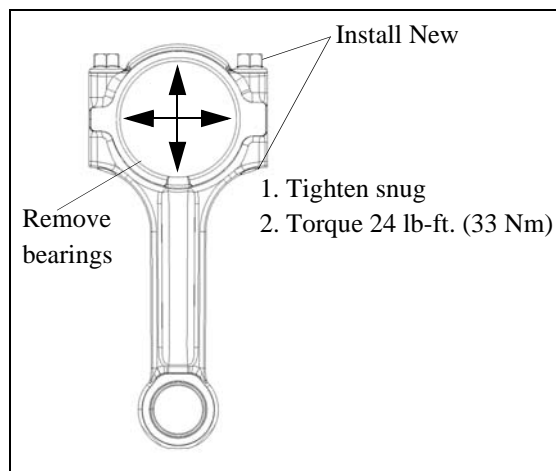

Connecting Rod (Big End) Diameter:
1.8892 - 1.8902" (47.987 - 48.011 mm)

Connecting Rod (Big End) Concentricity:
< 0.00047" (0.012 mm)

ENGINE

Connecting Rod Big End Bearing Selection

1. If using NEW connecting rods, install the bearing color that matches the color marked on the connecting rod cap as shown below.

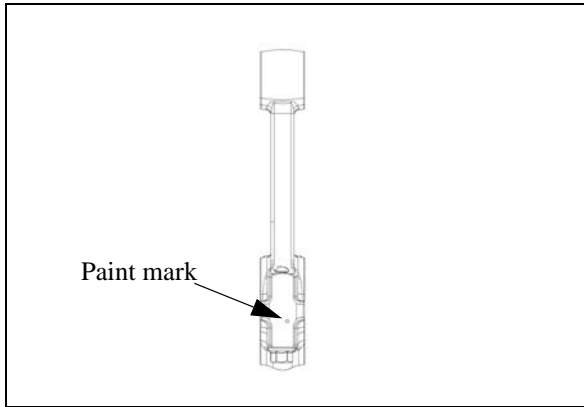

2. If re-installing the original connecting rod, select the appropriate bearing from the table below based on connecting rod big end I.D. measurements (page 5.47).

Bearing Size Selection Chart In Millimeters				
Connecting rod journal must be within standard size limits as determined by crankshaft measurements (See page 5.46).				
Con Rod Mark	Red	White	Blue	Yellow
Con Rod Big End Bore Diameter	47.987mm	47.993mm	47.999mm	48.005mm
	-	-	-	-
	47.993mm	47.999mm	48.005mm	48.011mm
Target Oil Clearance (Con Rod Bearing)	.023 mm - .057 mm			
Bearing color to install	Red	White	Blue	Yellow

Bearing Size Selection Chart In Inches				
Connecting rod journal must be within standard size limits as determined by crankshaft measurements (See page 5.46).				
Con Rod Mark	Red	White	Blue	Yellow
Con Rod Big End Bore Diameter	1.8892 in.	1.8895 in.	1.8897 in.	1.8899 in.
	-	-	-	-
	1.8895 in.	1.8897 in.	1.8899 in.	1.8902 in.
Target Oil Clearance (Con Rod Bearing)	.0009 in. - .0022 in.			
Bearing color to install	Red	White	Blue	Yellow

Piston / Piston Ring Inspection

1. Measure piston ring to ring land clearance with a thickness gauge (A) inserted between bottom edge of ring (B) and piston ring land (C). Replace both piston and rings if clearance exceeds service limit.
2. Repeat for 2nd ring.

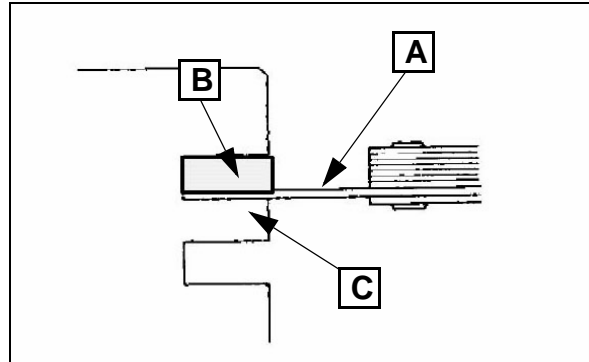

Piston Ring Removal

1. Carefully remove top compression ring by hand or using a ring removal pliers.

NOTICE

Do not expand the ring more than necessary to remove it from piston or ring may break or lose radial tension.

Piston ring pliers: Carefully expand ring and lift it off the piston.

By hand: Placing both thumbs as shown, spread the ring open and push up on opposite side. Do not scratch ring lands.

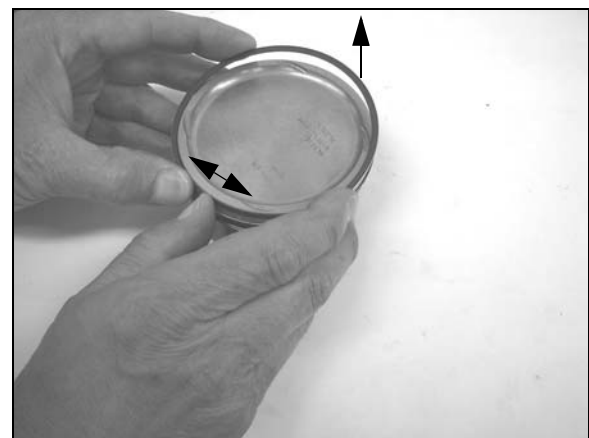

2. Repeat procedure for second ring.
3. Remove (3 piece) oil control ring. Remove top rail first, then bottom rail, then the expander.

Piston Ring Installed Gap

1. Place each piston ring (A) inside the cylinder (B) (from cylinder head side of crankcase). Use the piston to push the ring squarely into cylinder, as shown below.
2. Measure installed gap with a feeler gauge (C) at both the top and bottom of the cylinder.

IMPORTANT: A difference between top and bottom end gap measurements is a general indication of cylinder taper (wear). The cylinder should be measured for taper and out of round.

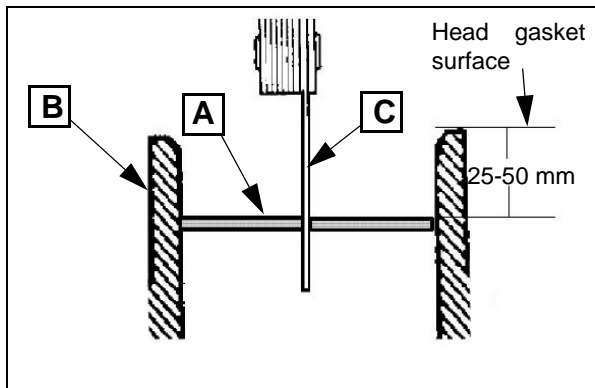

Piston Ring Installed Gap
Top: 0.014" ± 0.008" (0.36 ± 0.20 mm)
Second: 0.014" ± 0.008" (0.36 ± 0.20 mm)
Oil Control Rails:
0.0196" ± 0.010" (0.50 ± 0.25mm)

Piston Pin Bore Inspection

1. Measure piston pin bore.

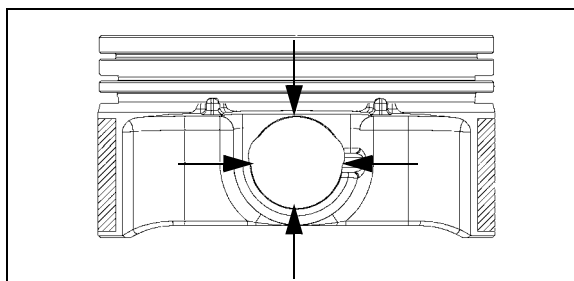

Piston Pin Bore:
0.7877" ± .0002" (20.007 ± .004 mm)

Cylinder Inspection

1. Remove all gasket material from gasket surface.
2. Lay a straight edge across cylinders (upper crankcase).
3. Use a thickness gauge to measure gap between straightedge and gasket surface. Measure at outer edges and center, repeating measurements with straightedge laid diagonally.

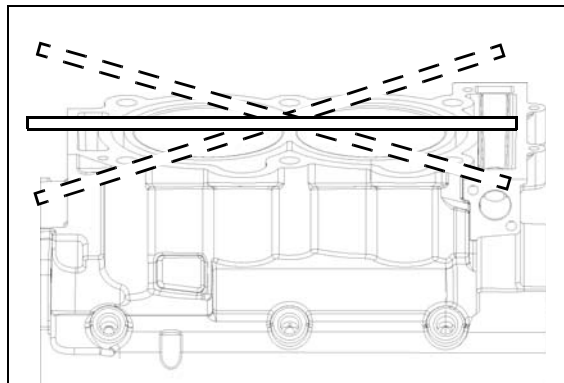

Cylinder Warp: .002" (0.05 mm) Max.

4. Inspect cylinder for wear, scratches, or damage.

IMPORTANT: DO NOT hone the cylinders or attempt to repair a damaged cylinder by honing. See "Honing - Important Information" on page 5.50

5. Inspect taper and out of round with a dial bore gauge.

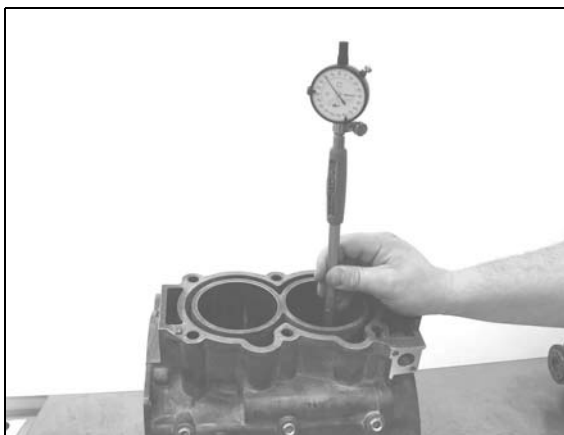

ENGINE

6. Measure in two directions (front to back and side to side) on three levels and record measurements. If cylinder is tapered or out of round beyond .001", the crankcase must be replaced.

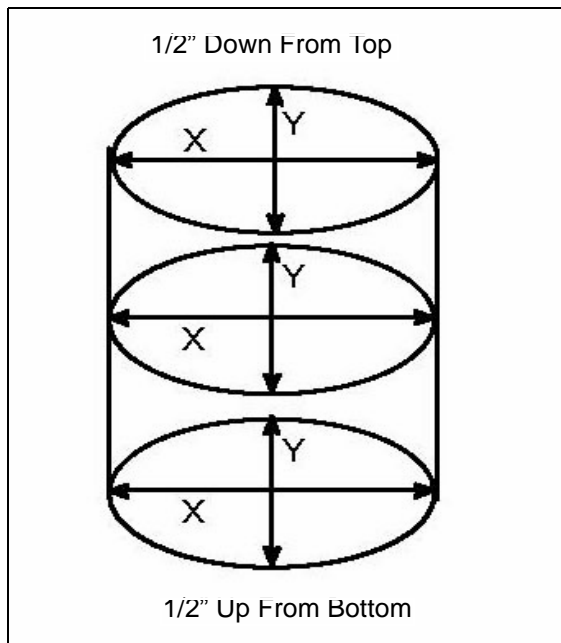

Cylinder Taper Limit:
.001" (.025mm) Maximum

Cylinder Out of Round:
Limit: .001" (.025 mm) Maximum

Standard Bore Size
3.4252" ± .0005 (87 mm ± .01mm)

Piston-to-Cylinder Clearance

Measure piston outside diameter at a point 33 mm down from piston crown, at a right angle to piston pin bore.

Subtract measurement from maximum measurement obtained in Step 6 of Cylinder Inspection.

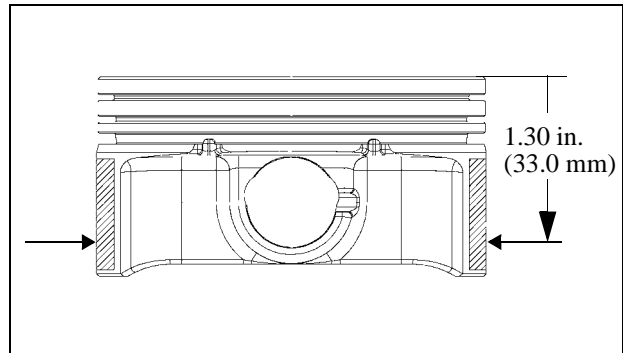

Piston to Cylinder Clearance:
.0021" ± .0013" (.053mm ± .03mm)

Piston O.D. (Standard):
3.4231" ± .0008" (86.947 ± .02 mm)

Honing - Important Information

The NiCaSil cylinders have a cross-hatch pattern of approximately 45 degrees to ensure piston ring seating, reduce ring vibration, and to aid in lubrication retention. The factory applied crosshatch is good for the service life of the cylinder and honing IS NOT required when installing new pistons and / or piston rings.

DO NOT attempt to hone the NiCaSil cylinders. A special process is required, and improper honing or use of the wrong type of abrasive stone will result in irreversible cylinder wall damage.

Any change in surface finish should be followed by cylinder measurement and an inspection for wear. If cylinders are damaged or worn beyond the service limit, they can be re-plated with NiCaSil one time only by a NiCaSil plating specialist.

If cylinder damage is excessive, or if cylinders have been replaced before, it will be necessary to replace the cylinder / crankcase assembly.

ENGINE ASSEMBLY

Crankcase Preparation - Upper

1. Refer to *Oil Flow Diagram* (page 5.4) and trace the oil path through the upper crankcase / cylinder. Flush all oil passages with solvent and then warm soapy water. Rinse with clear, warm water and dry with compressed air. Be sure passages are clean and dry before assembling the upper crankcase.

Piston Ring Installation

Apply clean engine oil to rings. Check installed gap before installing on piston. Clean accumulated carbon from ring grooves and oil ring lube holes if piston has been in service.

1. Place oil control ring expander in oil ring groove. Tips of expander gap (A) must face piston crown so scraper edge (B) of expander faces piston skirt.
2. Rotate expander in groove until butt ends are on intake side of piston. Ends must butt squarely together and must not overlap.
3. Install bottom rail first, then top rail with end gap located as shown at right.

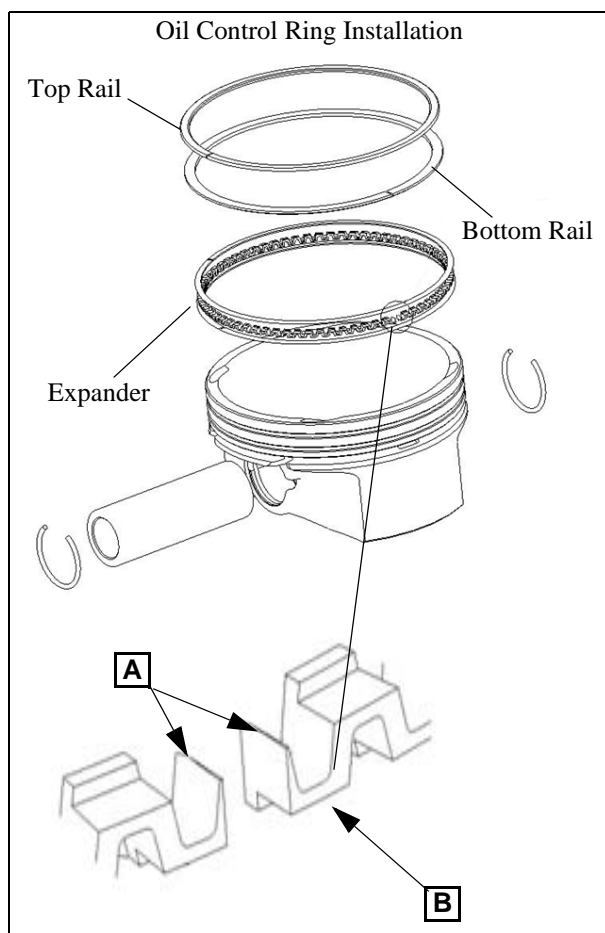

4. Install second ring with undercut facing bottom of piston. Rotate ring to place end gap generally toward (intake) side of piston as shown below.
5. Install top ring with "0" mark facing up (toward piston crown) and rotate to position the gap generally at the front as shown below.
6. Be sure top and second rings rotate freely in their grooves and do not bind when compressed by hand.

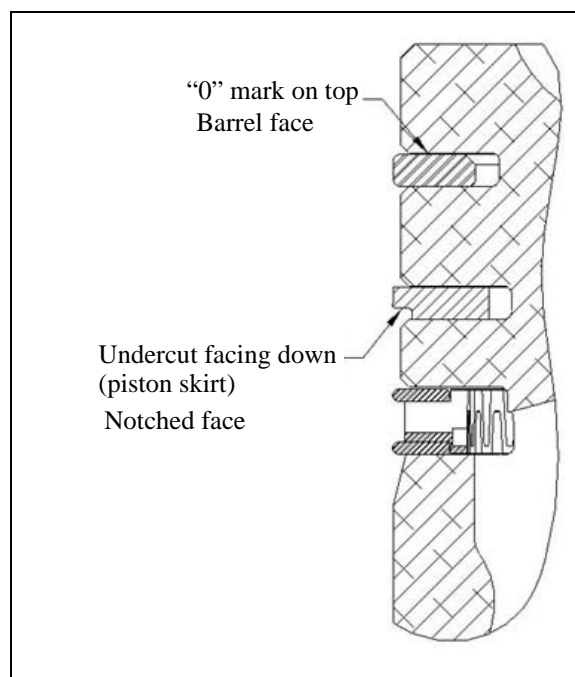
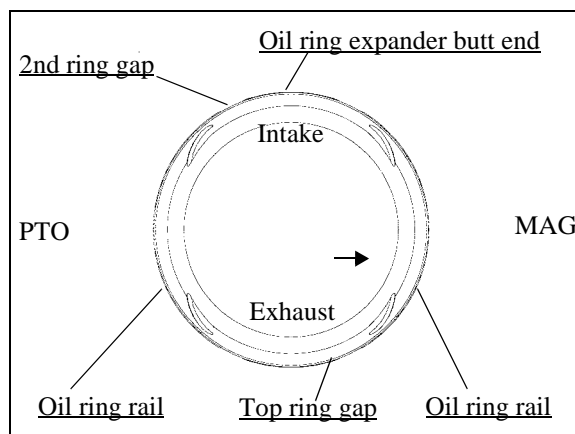

ENGINE

Piston / Connecting Rod Assembly

1. Lubricate connecting rod small end, piston pin bore, and piston pin with engine oil.

CAUTION

Do not re-use circlips. Circlips become deformed during the removal process.

Do not compress the new clip more than necessary to prevent loss of radial tension. Severe engine damage may result if circlips are re-used or deformed during installation.

2. Install a new circlip on one side of piston with gap UP (at the 12:00) or DOWN (at the 6:00) position.

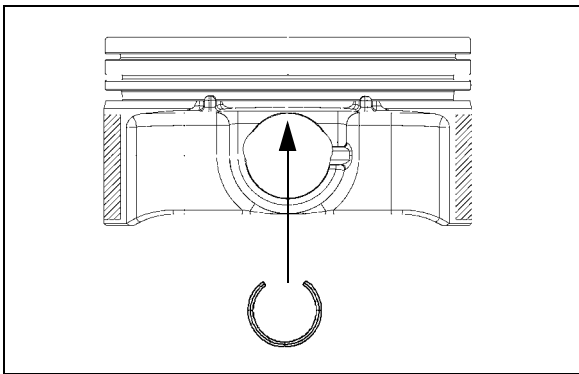

NOTE: If re-installing connecting rods, orient the marks on rod caps the same as when removed. Be aware of this direction when installing pistons to rods. If new connecting rods are being installed, they can be installed either way (there is no piston pin offset in the rod) however it is recommended they be installed with marks on both rods facing the same direction.

3. Place piston on connecting rod so arrow on crown of piston points toward MAG end of crankshaft (water pump end).
4. Push piston pin through rod and piston until it seats against the installed circlip.

IMPORTANT: Do not tap on pin or cause any sideways force to connecting rod. Warm piston crown with a heat gun if pin cannot be installed by hand, or use a piston pin installation tool. DO NOT apply heat directly to piston rings or a loss of radial tension could result.

5. Install the remaining circlip with gap at the top or bottom. Push the piston pin in both directions to make sure the clips are properly seated in the groove.

IMPORTANT: Never re-use a circlip that has been installed.

6. Check to be sure rings rotate freely in the grooves.

Piston / Connecting Rod Installation

1. Apply clean engine oil to piston assembly and cylinder walls of upper crankcase.
2. Be sure ring end gaps are positioned at least 120 degrees apart as shown below. Oil ring rails at least 60 degrees apart. (See "Piston Ring Installation" on page 5.51).
3. Apply engine oil to ring compressor band and install band (A) over piston rings.

CAUTION

Be sure compressor band end gap does not align with any ring end gap when compressing the rings.

4. Fully compress piston rings using compressor pliers (B) on band.

Piston Ring Compressor Band, 87mm: PV-43570-3

Piston Ring Compressor Pliers: PV-43570-1

5. Apply tape to the sides of connecting rods to protect cylinder from damage. Be sure to install piston with arrow (C) pointing to MAG (water pump) end of crankshaft.
6. Align piston with bore and push into cylinder until all rings are captive. Remove ring compressor.

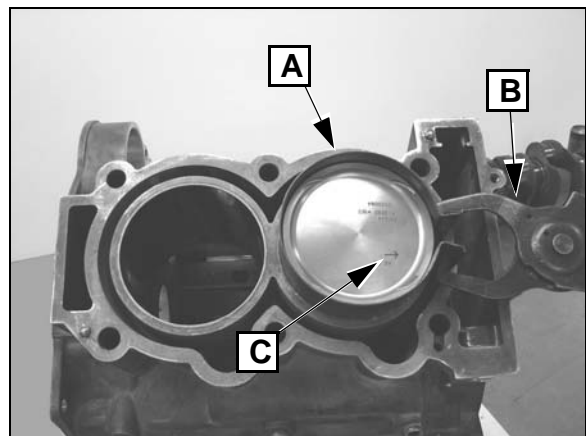

Crankshaft Installation

Refer to illustration *Crankcase Assembly (Upper)* page 5.54.

1. Clean the bearing bore surfaces of upper crankcase (main bearings), connecting rods, and connecting rod caps.
2. Align tab of a new main bearing with the slot in main bearing bore of crankcase. Press bearing insert firmly into place. Repeat for all main bearings, connecting rods, and connecting rod caps.

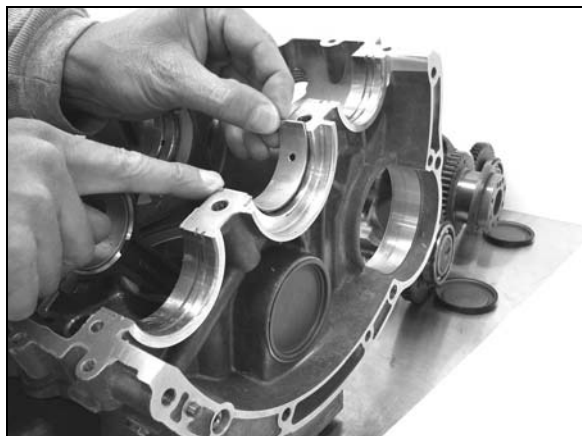

3. Apply Premium Starter Grease (2871460) to each main and rod bearing journal of crankshaft.
4. Loop cam chain over crankshaft sprocket.
5. Apply engine oil to new crankshaft seals and install seals on both ends of crankshaft with spring side of seal facing IN (toward crankshaft).
6. Carefully lower crankshaft into upper crankcase. Guide connecting rods onto rod journals of crankshaft as necessary.
7. Adjust crankshaft seals so each is flush with end of crankcase.
8. Clean threads of bolts and threads in connecting rod to remove all oil, grease, or assembly lubricant.
9. Apply Loctite 262 (Red) to the end 5 threads of rod bolts.
10. Install rod caps on rods with marks aligned.

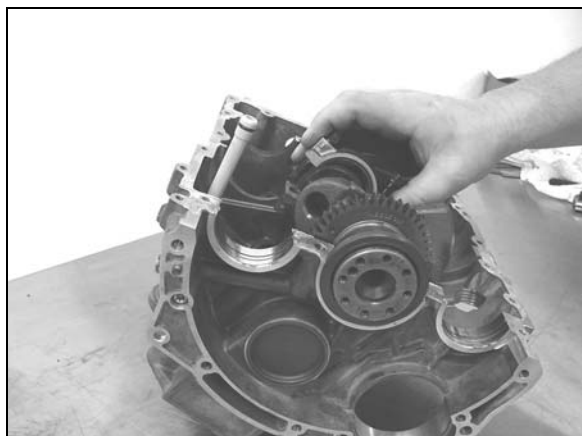

11. Install *new bolts* and tighten evenly until snug.
12. Torque bolts using the following procedure:

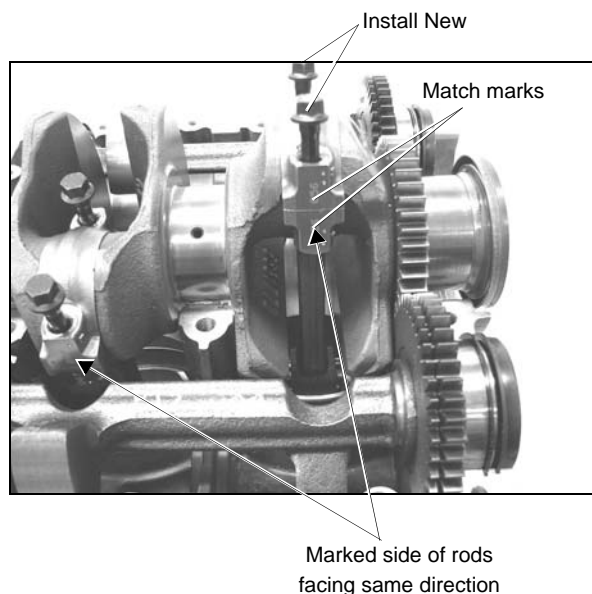

Connecting Rod Bolt Torque Procedure:

1. Torque to 24 lb-ft. (33 Nm)
2. Tighten an additional 60° (see image) →

Tighten bolt to align mark on bolt with mark on rod cap (60°)

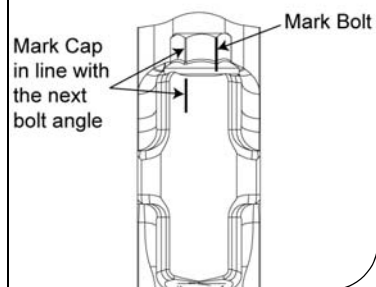

Oil Passage Tube

1. Replace O-rings (A) on both ends of the oil supply tube.
2. Apply a light film of engine oil to O-rings.
3. Push oil tube into upper crankcase.

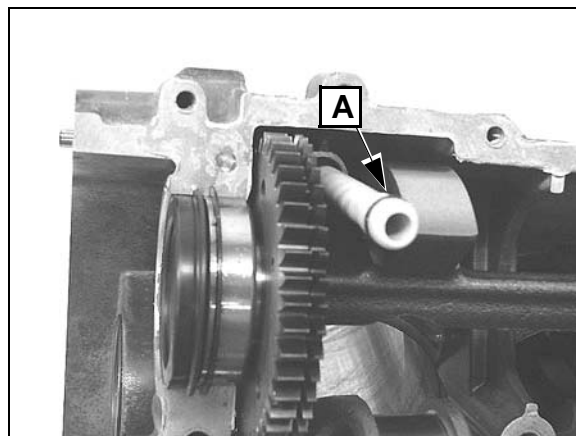

ENGINE

Crankcase Assembly - Upper

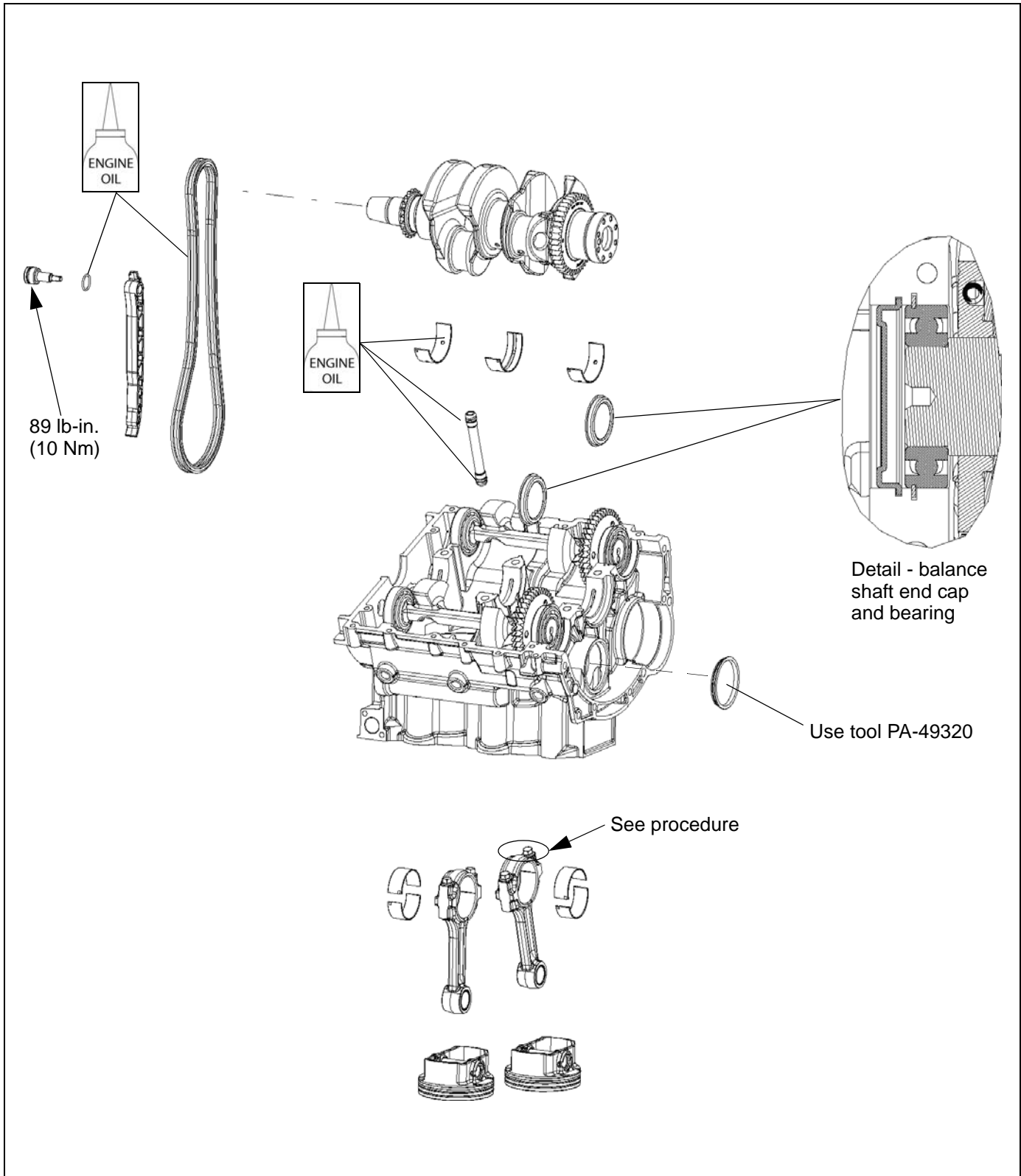

Balance Shaft Installation

See “Balance Shaft Timing” on page 5.56.

1. Balance shafts are identical but should be installed in the same location as removed.
2. Rotate crankshaft until the two alignment dots crankshaft gear are visible (page 5.56).
3. As viewed from gear end, rotate split gear counter clockwise until teeth are aligned and hold in position.

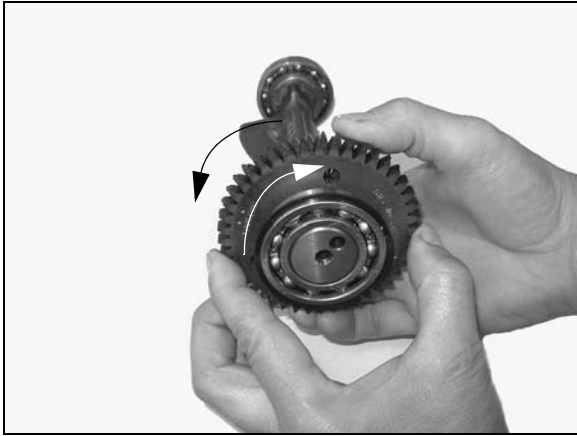

4. Install balance shaft, placing tooth with single dot between two dots on crankshaft gear. Align bearing locating ring in groove on crankcase and fully seat the shaft.

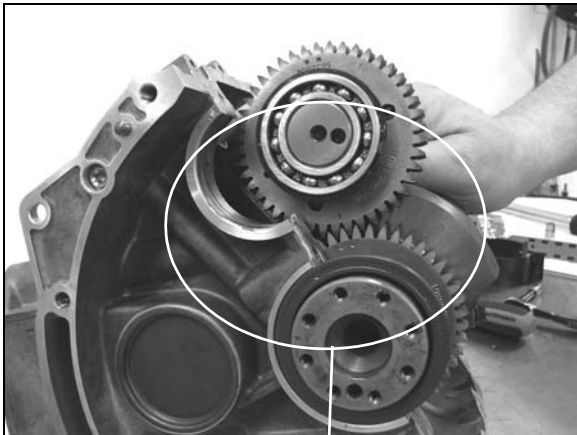

5. Rotate crankshaft until SINGLE dot on crankshaft gear is visible.
6. Align single dot of drive gear between two dots of balance gear.
7. Align bearing locating ring in groove on crankcase and fully seat the shaft.
8. Verify balance shaft timing is correct by comparing to illustration (page 5.56).
9. Place balance shaft end plugs in upper crankcase.

ENGINE

Balance Shaft Timing

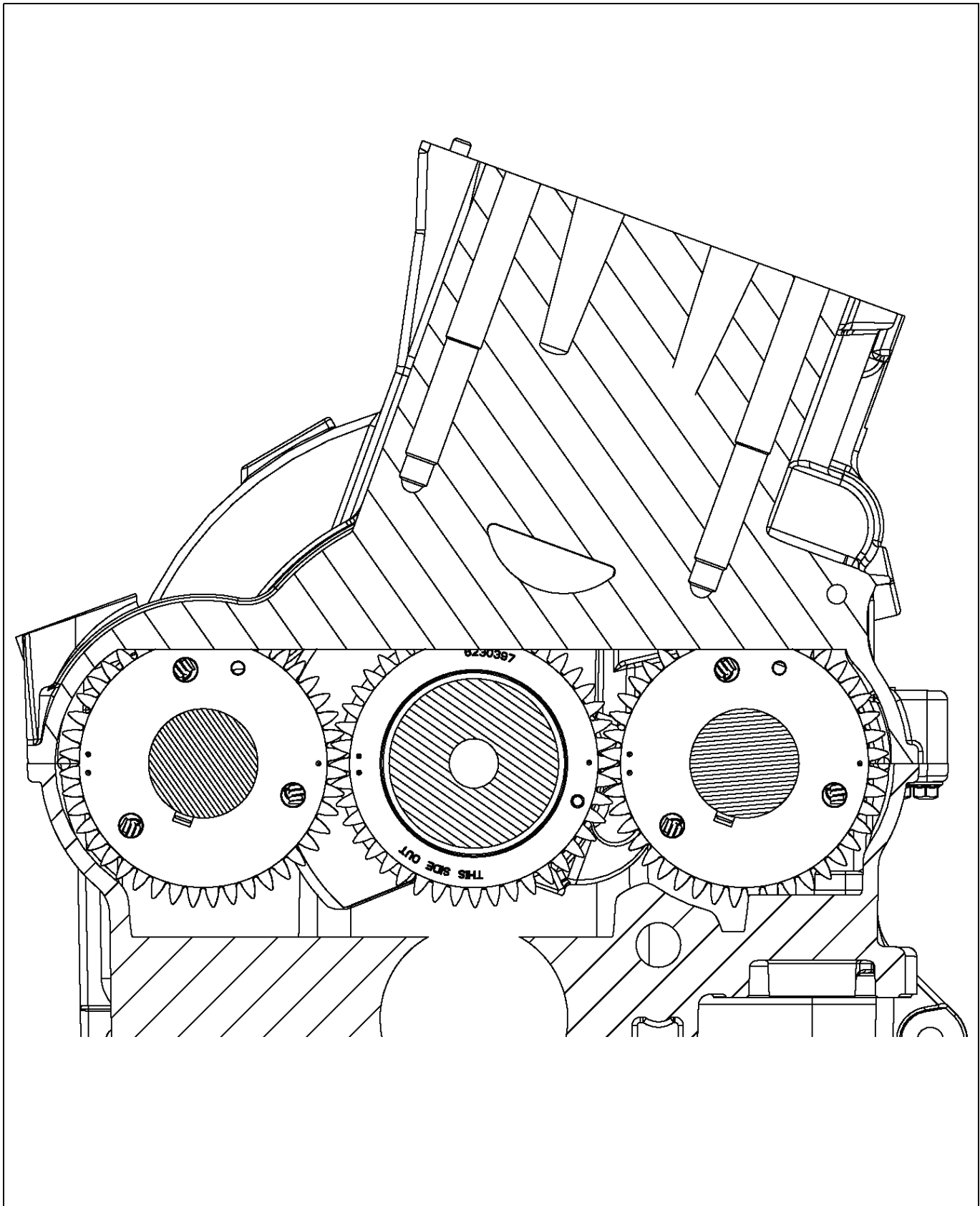

Crankcase Preparation (Lower)

Clean lower crankcase gasket sealing surfaces. Refer to *Oil Flow Diagram* (page 5.4) and trace the oil path from the through the lower crankcase. Flush all passages with solvent and then warm soapy water. Rinse with clear warm water and dry with compressed air. Be sure passages are clean and dry before assembling the lower crankcase. Assemble parts in order A-J.

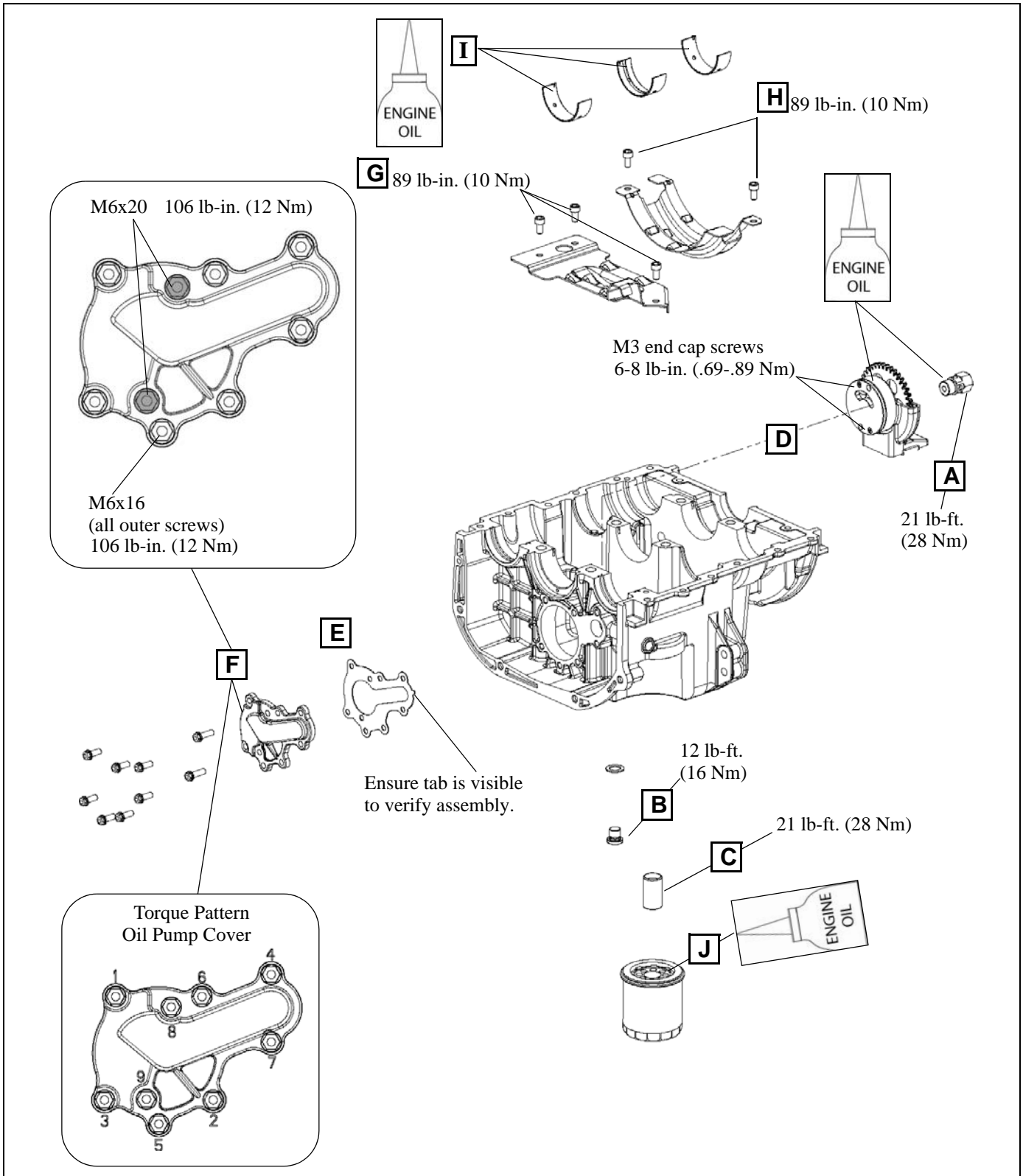

ENGINE

Crankcase Sealant and Torque Values

The diagram illustrates the crankcase assembly process. At the top, a perspective view of the engine block shows the crankcase being attached. Two callouts labeled 'ENGINE OIL' point to the gasket surfaces where the sealant should be applied. Below this, a collection of bolts is shown with their respective torque specifications: M6 x 20 (89 lb-in. / 10 Nm), M6 x 35 (89 lb-in. / 10 Nm), M9 x 160** (26 lb-ft. / 35 Nm), and M9 x 115** (26 lb-ft. / 35 Nm). A note states: '** Apply a light film of engine oil to flange and threads of M9 crankcase bolts.' At the bottom, two diagrams are provided: 'Torque Pattern' showing 20 numbered bolt locations on the crankcase, and 'Sealant Application' showing the application of sealant (part number 2871557) to the mating surfaces.

ENGINE OIL

ENGINE OIL

M6 x 20
89 lb-in.
(10 Nm)

M6 x 35
89 lb-in.
(10 Nm)

M9 x 160**
26 lb-ft.
(35 Nm)

M9 x 115**
26 lb-ft.
(35 Nm)

ENGINE OIL

ENGINE OIL

**** Apply a light film of engine oil to flange and threads of M9 crankcase bolts.**

Torque Pattern

Sealant Application
2871557

Crankcase Assembly

1. Prepare upper and lower crankcase and install all components as described on page 5.51 through page 5.57.
2. Inspect crankshaft seals to be sure they are aligned flush with ends of crankcase.
3. Be sure balance shaft end plugs are installed with retaining flange fitted in the grooves of crankcase.
4. Be sure oil passage tube is installed with new O-rings (page 5.53).
5. Clean crankcase mating surfaces to remove all oil and grease.
6. Apply a thin, continuous film of crankcase sealant PN 2871557 to upper and lower crankcase mating surfaces as shown on page 5.58. Do not allow sealant to dry before assembly.
7. Apply engine oil to crankshaft main bearings in the lower crankcase half.
8. Carefully place lower crankcase on upper case, making sure the oil supply tube and oil pump drive gear are aligned.
9. Tap with a rubber hammer to seat cases together.
10. Install all crankcase bolts and tighten all lightly by hand.
11. Inspect mating surfaces to be sure they are joined properly. Investigate the cause of any gaps.
12. Torque all crankcase in sequence shown on page 5.58 to final torque value, then repeat the sequence to verify final torque.
13. Install cylinder head (page 5.35).

WATER PUMP

Water Pump Impeller Removal

IMPORTANT: Water pump impeller removal is not required to remove the stator cover. If engine service does not include water pump repair, leave the water pump cover assembled to the stator cover and remove as an assembly.

NOTE: The water pump impeller can be removed without removing the engine.

See Chapter 4 “Cooling System” for procedure.

Water Pump Mechanical Seal Replacement / Coupler Shaft & Bearing Replacement

IMPORTANT: Water pump mechanical seal removal is not required to service the engine or to remove the stator cover. If engine service does not include water pump repair, remove the stator cover as an assembly.

NOTE: The water pump mechanical seal, coupler shaft, and bearing can be serviced without removing the engine.

See Chapter 4 “Cooling System” for procedure.

ENGINE

TROUBLESHOOTING

Engine

Spark Plug Fouling

- Restricted air filter (main or pre-cleaner) or breather system
- Improperly assembled air intake system
- Restricted engine breather system
- Oil contaminated with fuel
- Fuel quality poor (old) or octane too high
- PVT system calibrated incorrectly/ components worn or mis-adjusted
- Restricted exhaust
- Spark plug cap loose or faulty
- Incorrect spark plug heat range or gap
- Weak ignition (loose coil ground, faulty coil, or stator)
- Low compression

Engine Turns Over But Fails To Start

- No fuel
- Dirt in fuel line, filter, or injectors
- Fuel pump inoperative/restricted
- Fuel valve off or restricted flow
- Tank vent plugged or pinched
- Engine flooded
- Low compression (high cylinder leakage)
- No CPS signal (debris on CPS pole, damaged CPS causing incorrect air gap)
- No spark (spark plug fouled) ignition component failure

Engine Does Not Turn Over

- Dead battery
- Starter motor does not turn
- Engine seized, rusted, or mechanical failure

Engine Runs But Will Not Idle

- Restricted fuel system
- Low compression (valves incorrectly adjusted)
- Crankcase breather restricted

Engine Idles But Will Not Accelerate

- Spark plug fouled / weak spark
- Broken throttle cable
- Air intake obstructed
- Air box removed (reinstall all intake components)
- Reverse speed limiter limiting speed
- Incorrect ignition timing
- Restricted exhaust system
- Camshaft worn excessively
- PVT not operating properly

Engine Has Low Power

- Spark plug fouled
- Cylinder, piston, ring, or valve wear or damage (check compression)
- PVT not operating properly
- Restricted exhaust muffler
- Camshaft worn excessively

Piston Failure - Scoring

- Lack of lubrication
- Dirt entering engine through cracks in air filter or ducts
- Engine oil dirty or contaminated (water)

Excessive Smoke and Carbon Buildup

- Excessive piston-to-cylinder clearance
- Worn rings, piston, or cylinder
- Worn valve guides or seals
- Restricted breather
- Air filter dirty or contaminated

Low Compression

- No valve clearance
- Valve not seating properly (bent valve or carbon / debris accumulated on sealing surface)
- Cylinder head gasket leak
- Cylinder or piston worn
- Piston rings worn, leaking, broken, or sticking
- Bent valve or stuck valve
- Valve spring broken or weak
- Rocker arm sticking

Backfiring

- Fouled spark plug or incorrect plug or plug gap
- Speed limiter system malfunction
- Exhaust system air leaks
- Ignition system faulty:
 - Spark plug cap cracked / broken
 - Ignition coil faulty
 - Ignition switch circuit faulty
 - Poor connections in ignition system
 - Ignition timing incorrect
 - Sheared flywheel key
- Valve sticking

CHAPTER 6

TRANSMISSION

TRANSMISSION SPECIFICATIONS..... 6.2
 TORQUE SPECIFICATIONS6.2
 LUBRICATION SPECIFICATIONS.....6.2
 SHIFT LINKAGE / GEAR SELECTOR 6.2
 SHIFT LINKAGE INSPECTION6.2
 GEAR SELECTOR REMOVAL.....6.2
 TRANSMISSION SERVICE..... 6.3
 TRANSMISSION REMOVAL6.3
 TRANSMISSION DISASSEMBLY6.4
 TRANSMISSION SHAFT SERVICE.....6.8
 TRANSMISSION ASSEMBLY6.10
 TRANSMISSION INSTALLATION6.14
 TRANSMISSION EXPLODED VIEW6.16
 TROUBLESHOOTING..... 6.18



Midwest Manuals

sales@midwestmanuals.com

www.midwestmanuals.com

TRANSMISSION

TRANSMISSION SPECIFICATIONS

Torque Specifications

ITEM	TORQUE VALUE
Transmission Fill Plug	10-14 ft. lbs. (14-19 Nm)
Transmission Drain Plug	10-14 ft. lbs. (14-19 Nm)
Transmission Case Screws	15-20 ft. lbs. (20-27 Nm)
Oil Deflector Plate Screws	7-10 ft. lbs. (9-14 Nm)
Bell Housing Screws	50-60 ft. lbs. (68-81 Nm)
Bellcrank Nut	12-18 ft. lbs. (16-24 Nm)
Shift Detent Plug	17-23 ft. lbs. (23-31 Nm)
Transmission Coupler Nut	115-125 ft. lbs. (156-170 Nm)

Lubrication Specifications

TRANSMISSION	CAPACITY
Synthetic Sportsman XP Transmission Fluid (PN 2877606) (Quart)	32 oz. (946 ml)

SHIFT LINKAGE / GEAR SELECTOR

Shift Linkage Inspection

1. Remove the seat and upper RH side panel (see Chapter 9).
2. Inspect the linkage rod pivot end attached to the transmission bellcrank and the snap linkage attached to the gear selector.

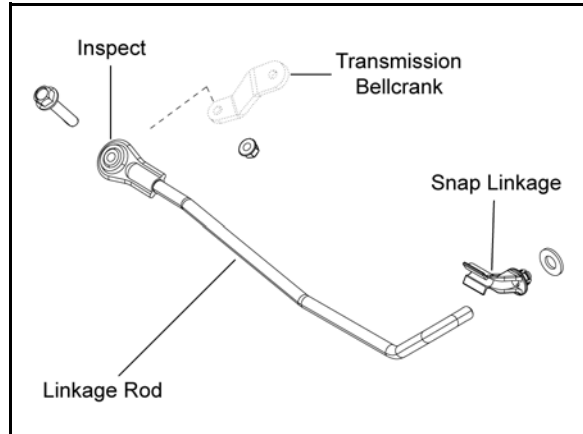

NOTE: Linkage rod length and angle is preset.

3. Replace any components that appear worn or damaged.

Gear Selector Removal

1. Remove the seat and upper RH side panel (see Chapter 9).
2. Push linkage rod out of the snap linkage at the gear selector.
3. Remove the retaining screw from the back side and pull the gear selector out from the frame support as an assembly.

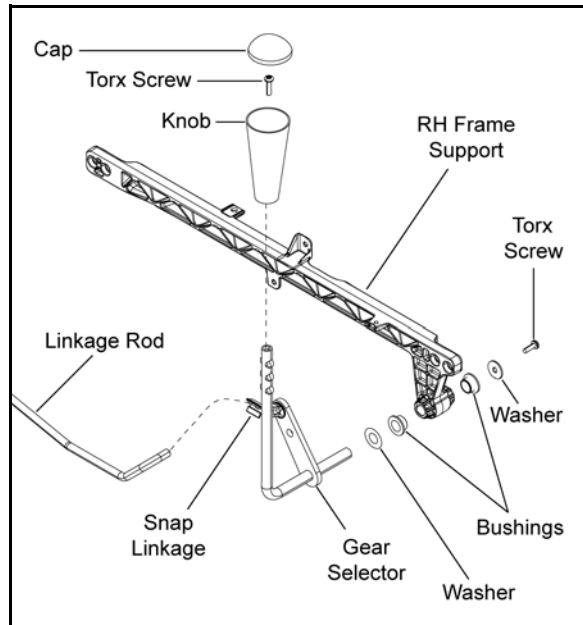

NOTE: Remove RH frame support to ease removal.

TRANSMISSION SERVICE**Transmission Removal**

1. Position the vehicle on a level surface.
2. Remove the seat and side panels (see Chapter 9).
3. Disconnect the negative (-) battery cable (see Chapter 2).
4. Remove the rear cab and footwells (see Chapter 9).
5. Thoroughly clean the engine, transmission and chassis.
6. Drain the transmission fluid (see Chapter 2).
7. Remove the left rear wheel, lower left-hand frame support and outer PVT cover (see Chapter 7 "DRIVE BELT - Belt Removal").
8. Remove the PVT intake duct from the transmission, and the PVT outlet duct from the inner PVT cover (see Chapter 7).
9. Remove the (4) bolts retaining the rear propshaft to the rear gearcase input shaft. Slide the shaft off the transmission output shaft and out from the vehicle.



10. Disconnect the wheel speed sensor located on the lower right-hand side of the transmission.
11. Disconnect the gear selector switch from the top of the transmission.
12. Disconnect the linkage rod from the gear selector.



13. Remove the high tension leads from the engine and remove the (2) nuts from each exhaust flange at the engine.

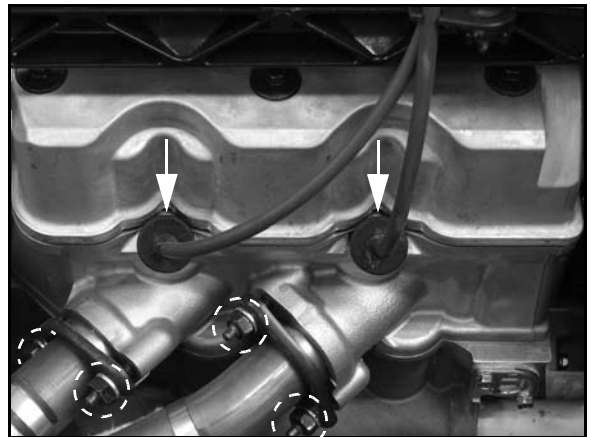

14. Remove the exhaust springs retaining the exhaust pipe to the silencer and remove the pipe from the vehicle.
15. Remove the (7) bolts retaining the transmission to the engine.



16. Remove the (2) vent lines from the top left portion of the transmission.

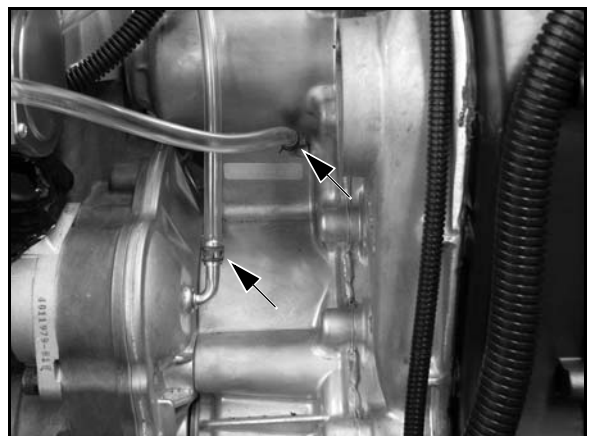

17. Remove the lower right airbox retaining screw.

TRANSMISSION

18. Remove the (4) bolts securing the right-hand frame support and remove the support from the vehicle.

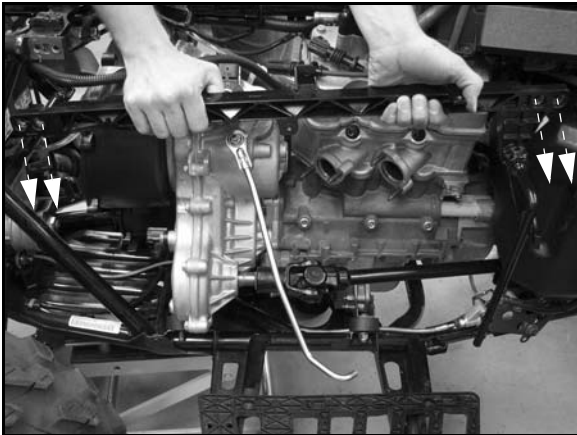

22. Once you have cleared the coupler, carefully lift the transmission assembly out the right side the of vehicle.

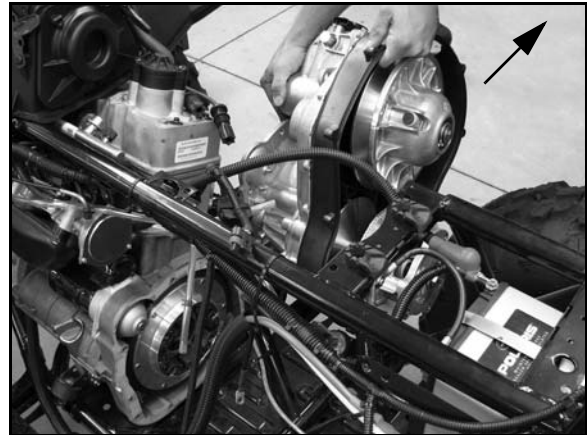

19. Remove the (2) through-bolt fasteners that mount the transmission to the isolator mount on the lower LH side.



Transmission Disassembly

1. Remove the drive belt, drive clutch and driven clutch (see Chapter 7 "PVT SYSTEM SERVICE - Disassembly").
2. Remove the (10) screws that secure the inner PVT cover to the transmission case and remove the cover.

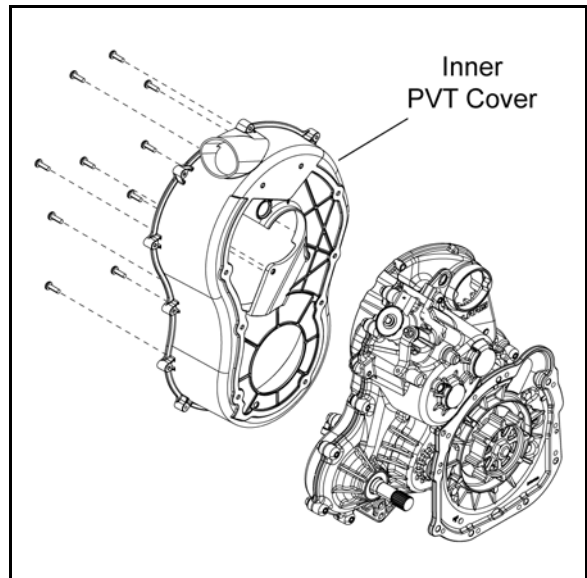

20. Using a T45 driver, remove the screw from the top of the isolator mount on the lower RH side.

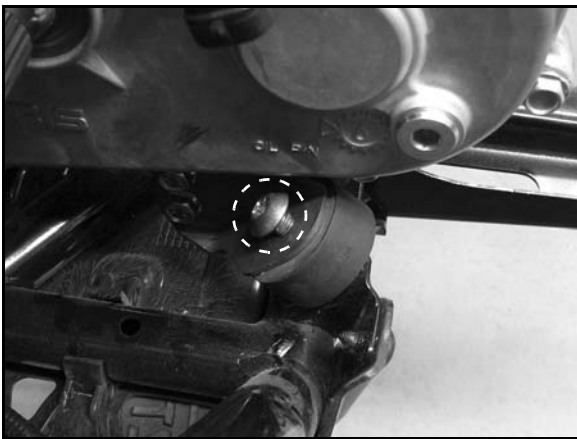

3. Remove (2) retaining bolts from the transmission cover (see Step 7). These are thread forming bolts that can be used to hold the coupler during removal and installation.

21. Carefully slide the transmission away from the engine and remove the front propshaft from the transmission shaft.

- Thread the (2) bolts into the transmission case pin holes to hold the coupler.

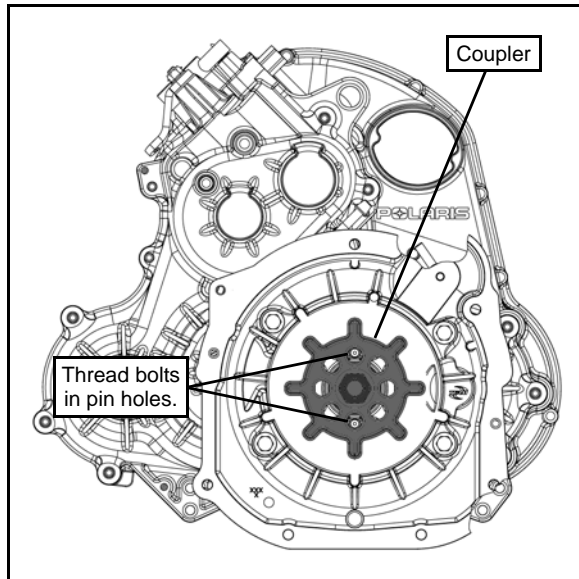

- Remove the retaining nut and transmission coupler.
- Place the transmission in neutral by moving the bellcrank.
- Lay the transmission down with the cover facing up and remove the bolts retaining the transmission cover.

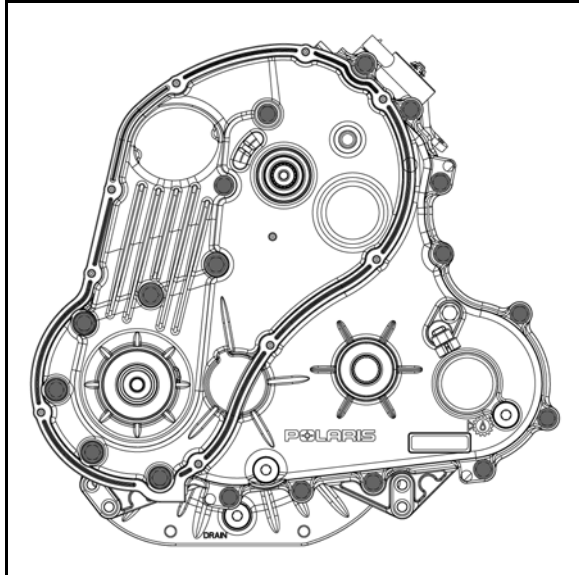

- Carefully lift up on the cover. Use a soft-faced hammer to tap on the input shaft and rear output shaft to ease cover removal.

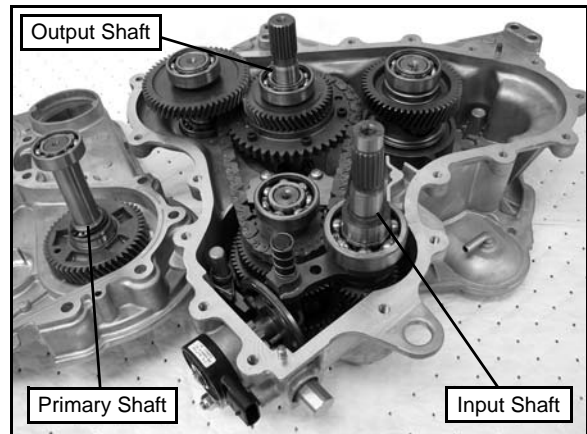

- Lift up on the rear output shaft assembly and remove the front output shaft assembly.

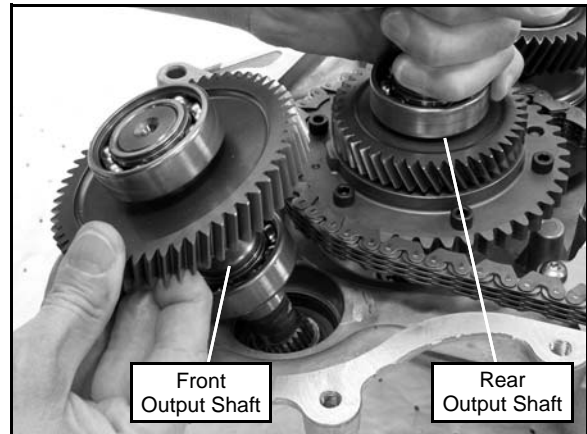

- Remove the (2) screws retaining the oil deflector plate.



TRANSMISSION

11. Lift up on the rear output shaft assembly enough to remove the compensator assembly.

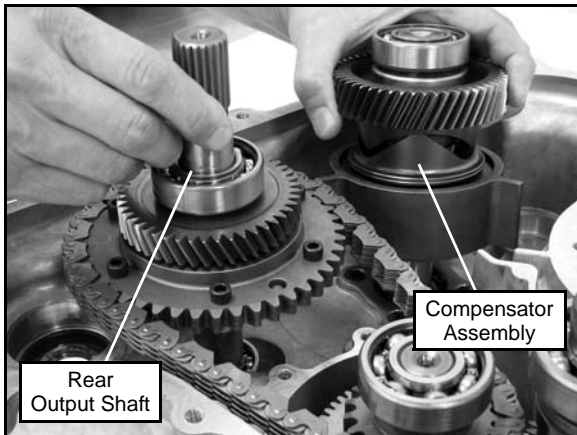

14. Lift up on each end of the shift fork and rotate the fork out of the shift shaft cam.

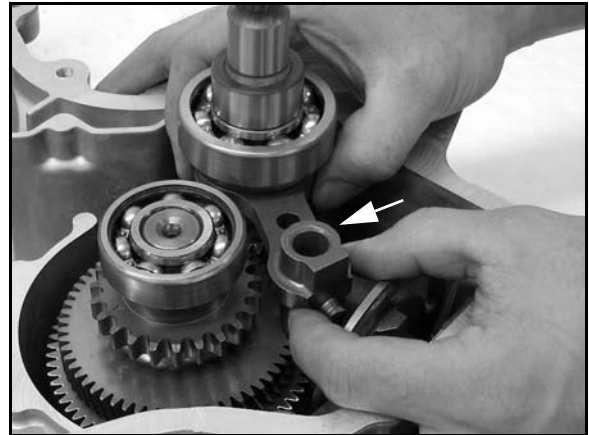

12. Remove the rear output shaft assembly and silent chain from the transmission.



15. Repeat the previous step to remove the lower shift fork.

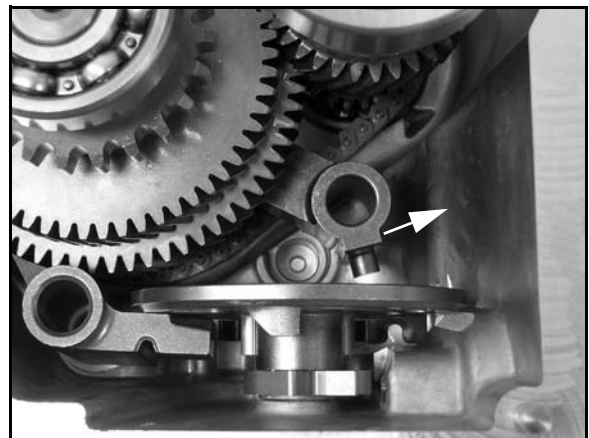

13. Remove the springs, shift shaft rail and park shaft rail.

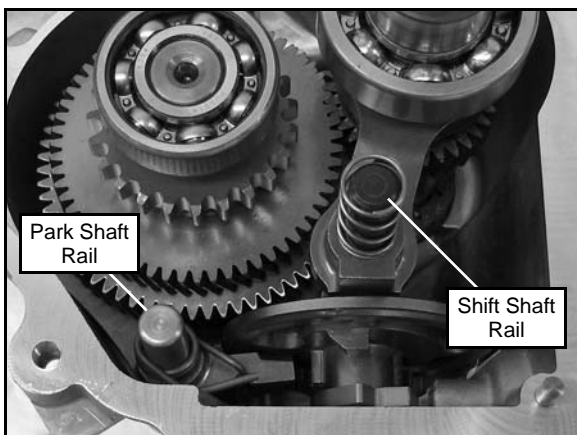

16. Remove the input shaft assembly and reverse shaft assembly together from the transmission.

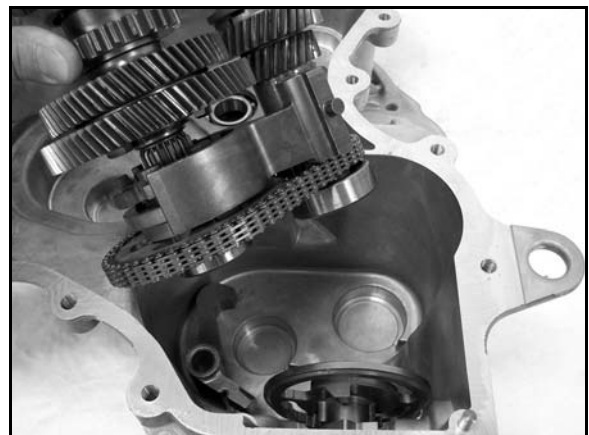

17. If servicing either shaft assembly, remove the reverse silent chain and separate the shaft assemblies.

18. Inspect all bearings, gear teeth, engagement dogs and silent chain.

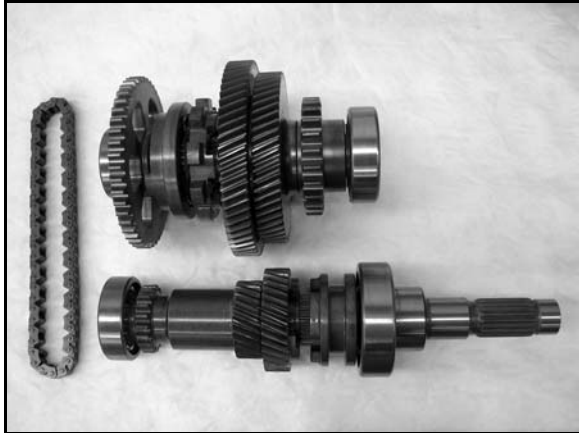

19. Remove the detent plug, snap ring, washer and gear selector switch.

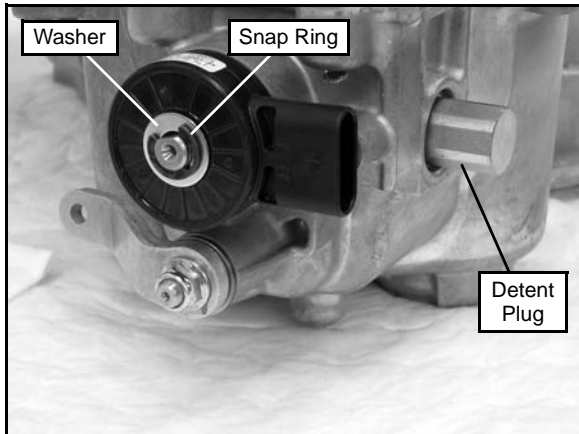

20. Remove the retaining ring and washer from the cam shift shaft. Remove the nut, bellcrank and washer from the bellcrank shift shaft.

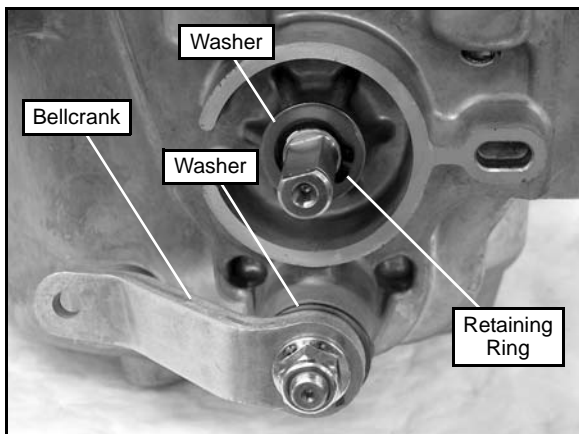

21. Remove both shift shafts from the transmission as an assembly. Lightly tap on each shaft to ease removal.

TRANSMISSION

Transmission Shaft Service

Use the exploded views within this section when servicing the transmission shafts.

Shaft bearings can be serviced using an arbor press.

Input Shaft

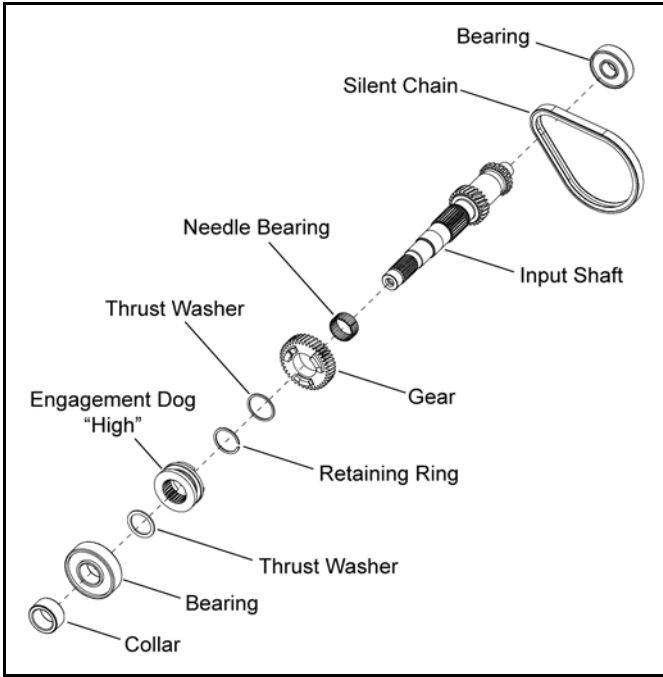

Primary Shaft

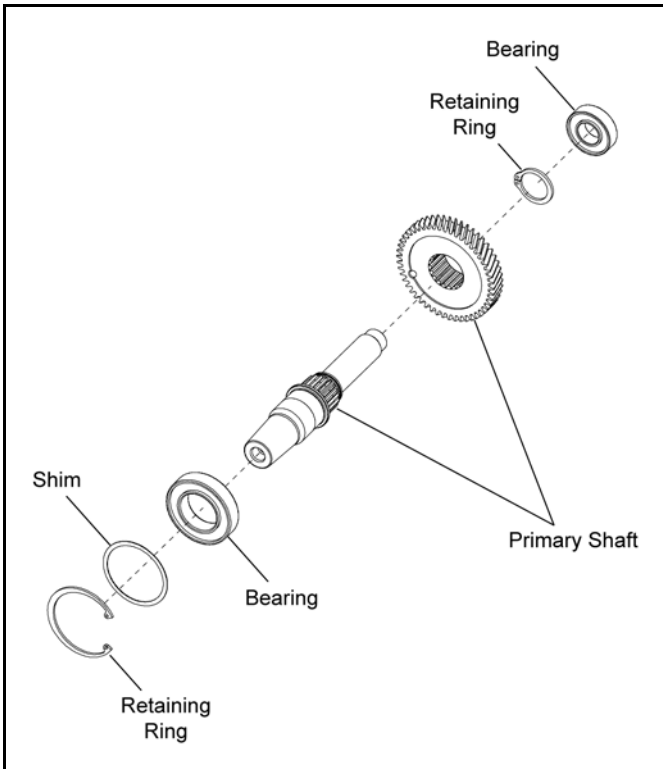

Rear Output Shaft

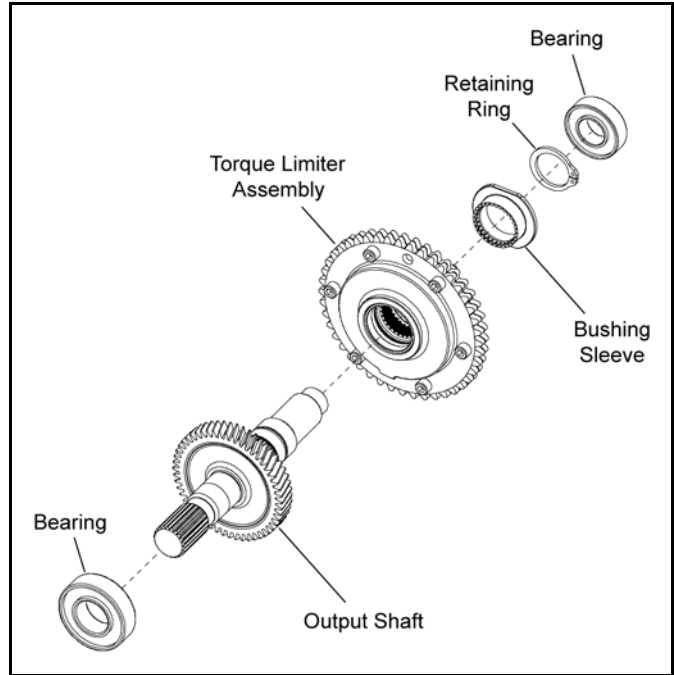

Reverse Shaft

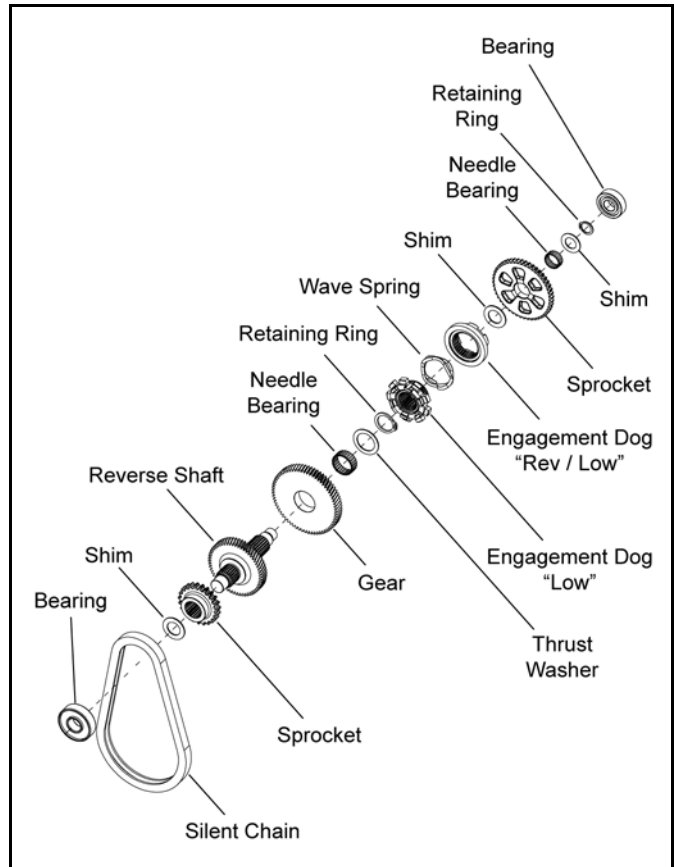

Compensator Shaft

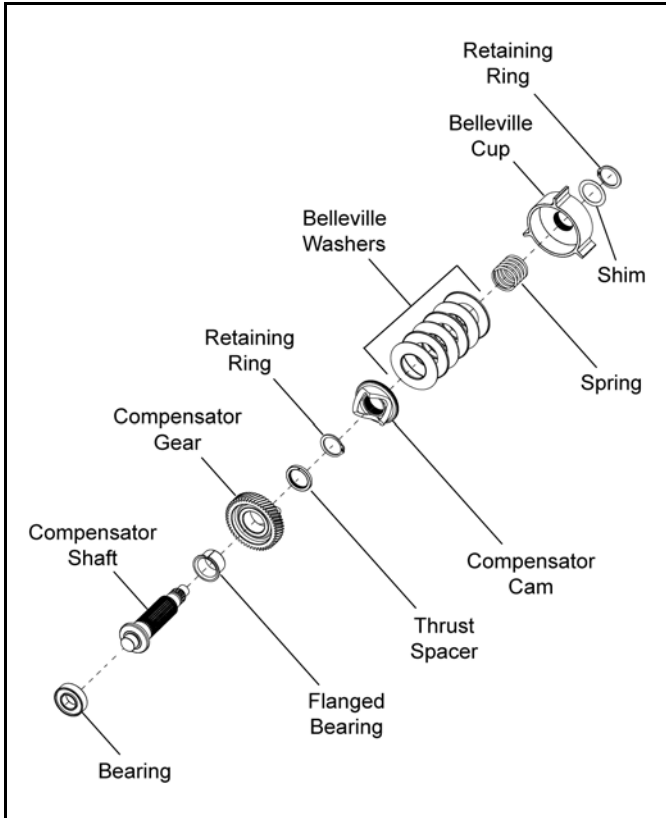

NOTE: Stack the belleville washers and place them into the belleville cup upon assembly as shown. The "UP" stamping on each washer should face out when assembling the washer stack.

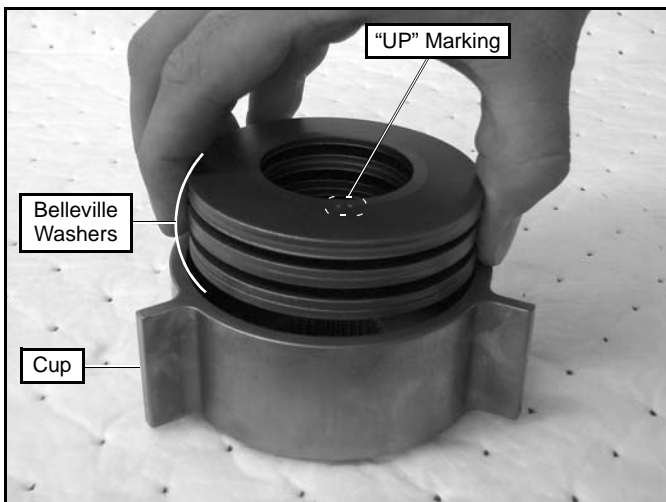

Cam Shift Shaft

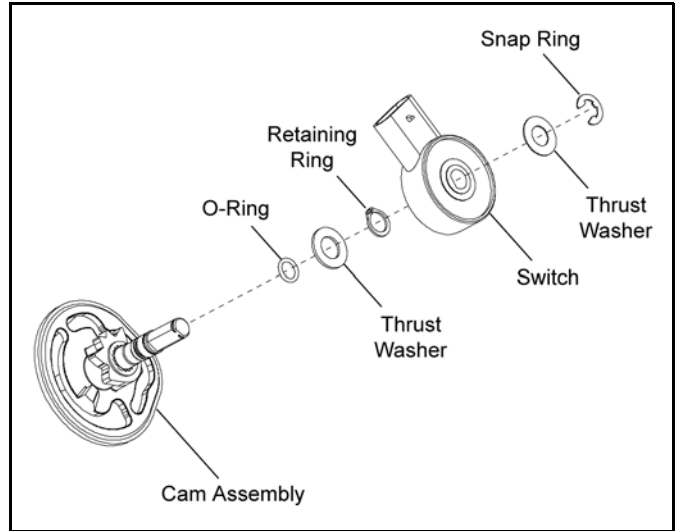

Bellcrank Shift Shaft

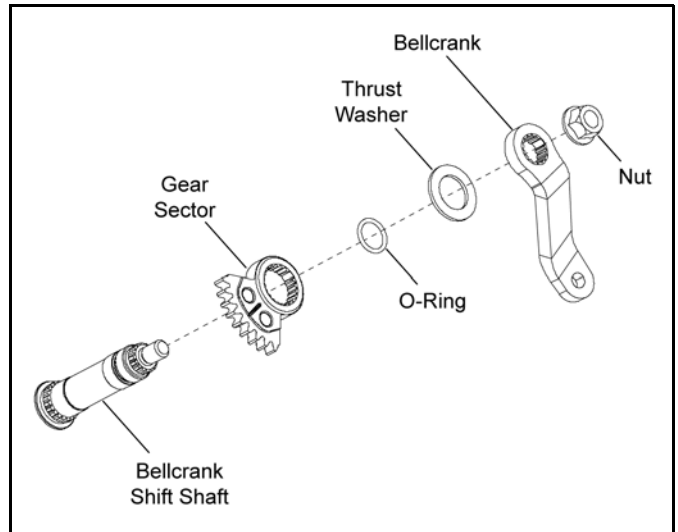

6

TRANSMISSION

Transmission Assembly

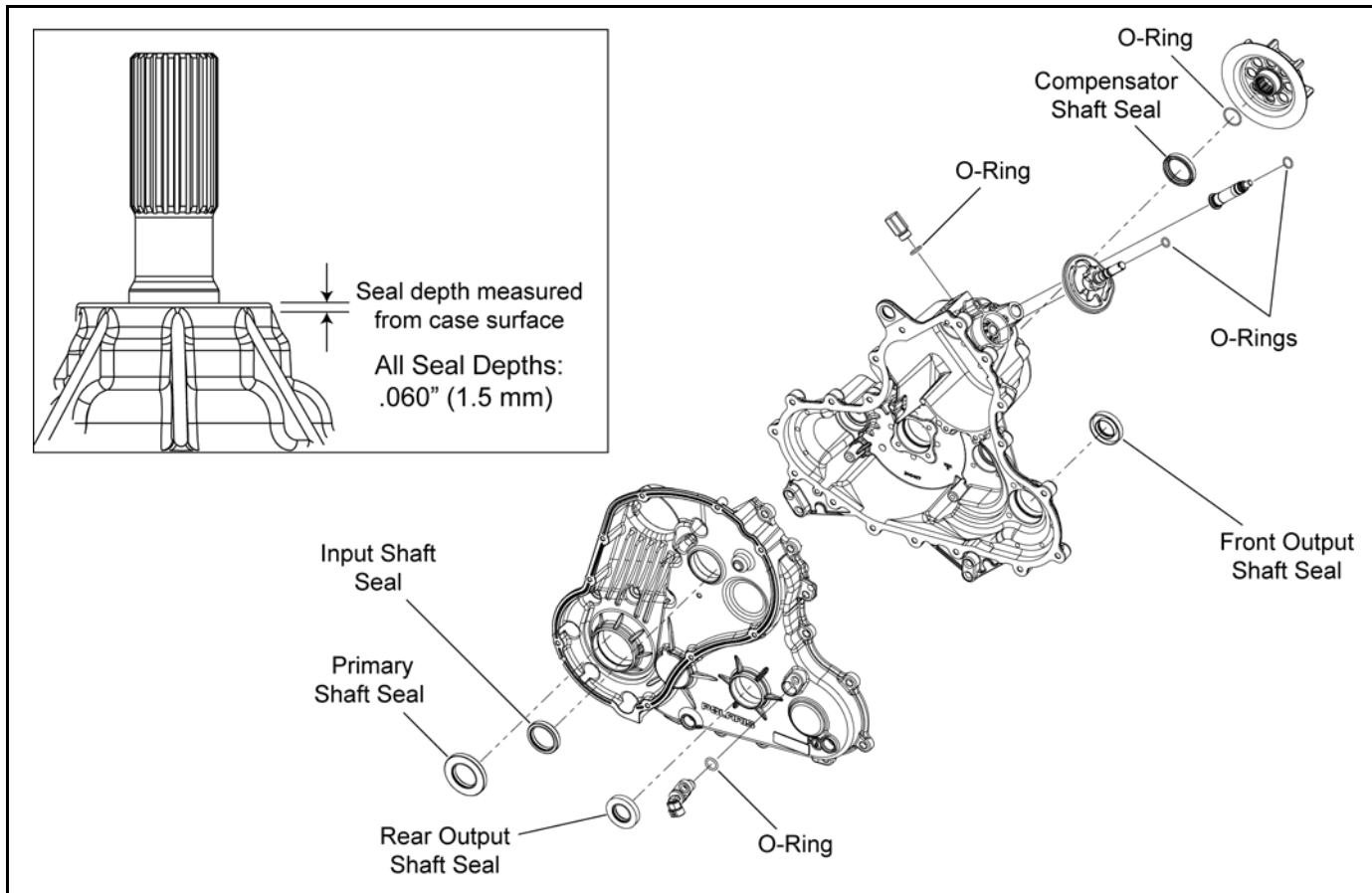

1. Thoroughly clean the transmission case halves and shafts.
2. Inspect all seals and O-rings for damage. If transmission was disassembled, seal and O-ring replacement is recommended (see exploded view above).
3. If the cam shift shaft was disassembled, install the detent gear with the step facing the O-ring.
4. If the bellcrank shift shaft was disassembled, install the gear sector with the step facing the O-ring.

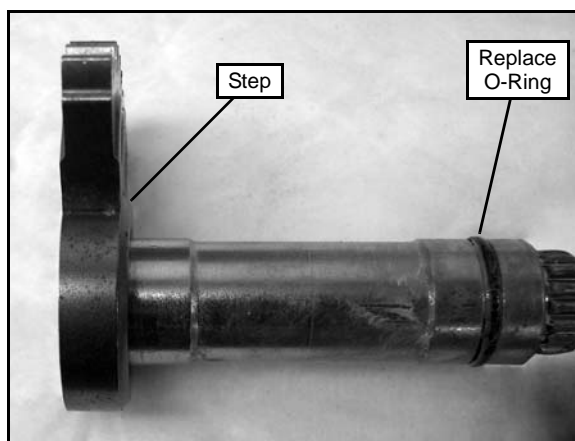
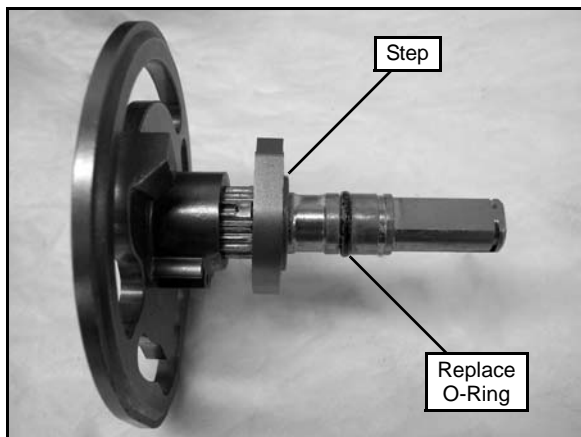

5. Install new O-rings on both shift shafts and lubricate prior to installation.

NOTE: Both shift shafts have skip-tooth keyed splines for assembly purposes.

- Align the timing marks on the cam shift shaft and bellcrank shift shaft.

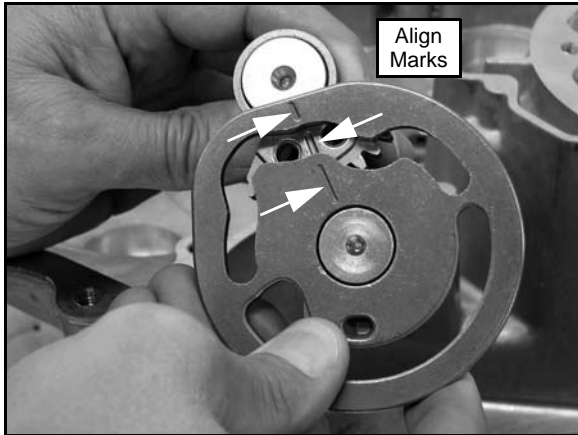

- Place the two shafts into the transmission as an assembly.



IMPORTANT: Gently rock or twist the shift shafts upon installation to prevent from damaging the new O-rings. Forcing the shift shafts straight into the transmission housing may cut the O-rings.

- Install the washer over the bellcrank shift shaft and install the bellcrank by aligning the skip-tooth splines.

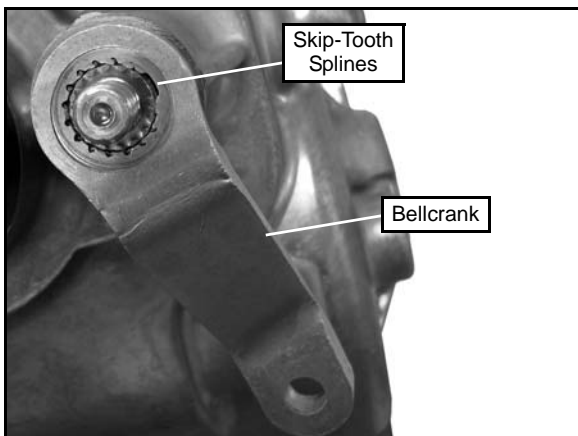

- Install the retaining nut and torque to specification.

 = T
Bellcrank Retaining Nut: 15 ft. lbs. (20 Nm)

- Install the washer and a new retaining ring onto the cam shift shaft. The retaining ring should be tight on the shaft.
- Install the transmission switch, washer and snap ring.

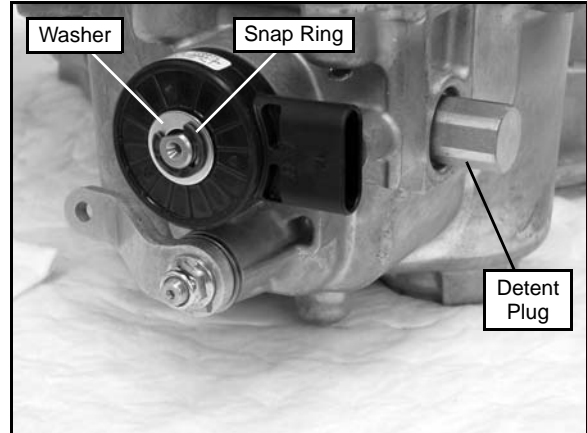

- Install the detent plug and torque to specification.

 = T
Detent Plug: 17-23 ft. lbs. (23-31 Nm)

- Assemble the input shaft and reverse shaft with the lower shift fork and park pawl installed.

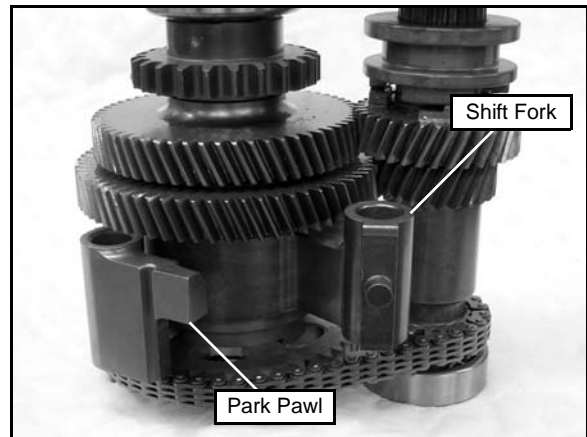

- Place the assembly into the transmission housing making sure to move the park pawl arm behind the shift shaft cam during installation.

TRANSMISSION

15. Lift up on the lower shift fork and rotate the end into the cam.

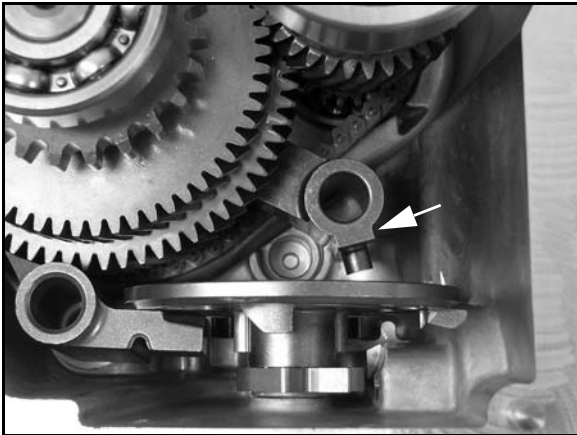

16. Install the upper shift fork and rotate the end into the cam.

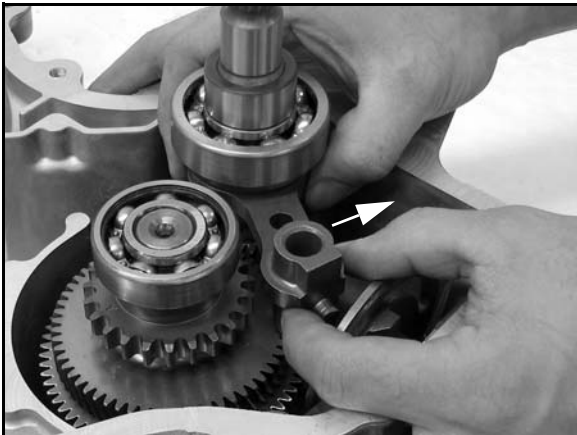

17. Install both rails and springs.

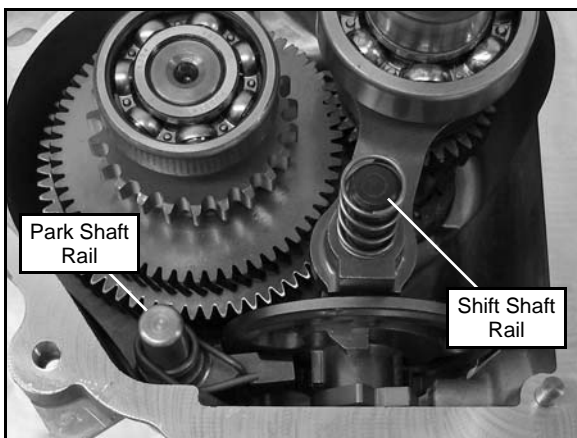

NOTE: Make sure the spring is flush with the top of the shift shaft rail. If not flush, the rail may not be fully seated.

18. Install the oil deflector plate and install new retaining screws. Torque screws to specification.



Deflector Plate Retaining Screws:
7-10 ft. lbs. (9-14 Nm)

19. Install the rear output shaft assembly and silent chain.
20. Lubricate all seal lips to prevent damage upon assembly.
21. Lift up slightly on the rear output shaft and install the compensator shaft and front output shaft assemblies.
22. If primary shaft was serviced, reinstall shaft assembly into the transmission case. Apply grease to the primary shaft shim(s) and place them into the transmission cover.
23. Carefully install the transmission cover onto the transmission. Apply even pressure to cover while setting into place. A soft-faced hammer can be used once the cover is started and aligned.

IMPORTANT: Take care not to damage seals during cover installation.

24. Install the retaining bolts and torque to specification. Leave (2) bolts out to use later when tightening the coupler.

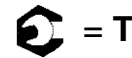

Transmission Cover Bolts:
15-20 ft. lbs. (20-27 Nm)

25. Install a new O-ring onto the compensator shaft prior to installing the transmission coupler.

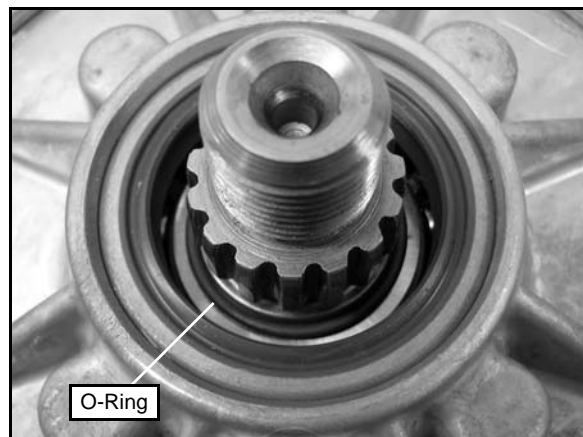

IMPORTANT: Be sure to install the O-ring all the way down onto the shaft, past the groove.

26. Install the transmission coupler and cone washer (dome facing up).
27. Apply Loctite™ 2760 to the shaft threads and install the coupler retaining nut.
28. Hold the transmission coupler using the (2) transmission cover bolts that were left out. Thread the bolts into the transmission case and torque the coupler nut to specification.

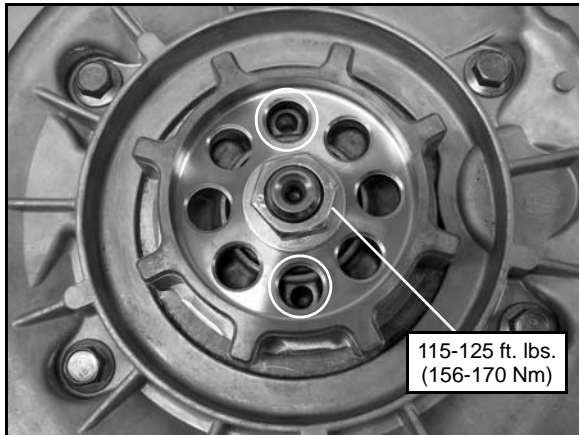

Transmission Coupler Retaining Nut:
115-125 ft. lbs. (156-170 Nm)

29. Remove the (2) bolts holding the coupler and install them in the transmission cover. Torque the bolts to specification (see Step 24).
30. Remove the old silicone material from the inner PVT cover and transmission case using a wire brush. Clean both surfaces thoroughly in preparation for assembly.
31. Inspect the inner PVT cover. Replace if cracked or damaged. The mating surface must be clean to ensure adhesion of new silicone sealant.
32. Be sure to “flame treat” the inner PVT cover prior to applying silicone to ensure good adhesion. Pass the flame of a propane torch back and forth quickly over the area where the silicone is to be applied (2-3 inches from the flame tip is recommended). Do not hold the torch too close to the surface. Keep the torch moving to prevent damage.

33. Apply RTV silicone sealant to the outside edge of the inner PVT cover to ensure a water tight fit between the cover and the transmission.

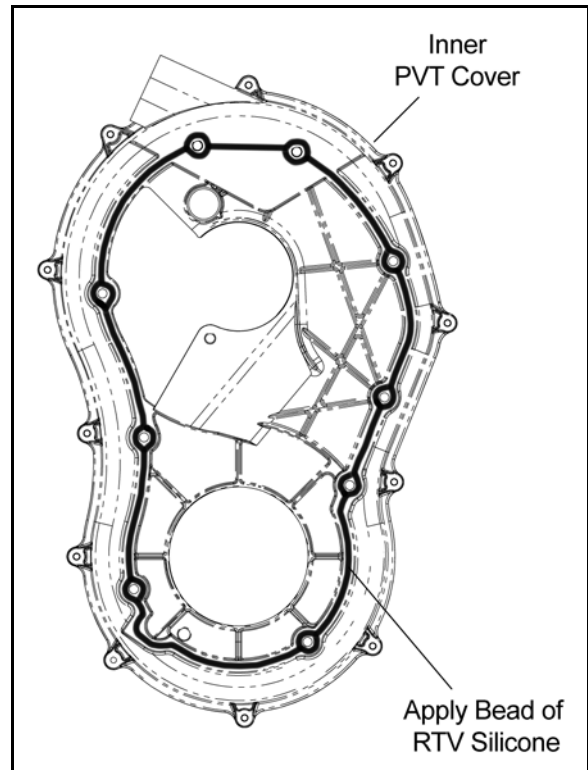

34. Install the cover and torque the inner PVT cover screws to specification.



Inner PVT Cover Screws:
6-8 ft. lbs. (8-11 Nm)

35. Wipe away any excess silicone sealant.
36. Install the drive clutch, driven clutch and drive belt (see Chapter 7 “PVT SYSTEM SERVICE - Disassembly”).

TRANSMISSION

Transmission Installation

1. Remove the rubber coupler and inspect it for signs of excessive wear or damage. Replace as needed.
2. Install the rubber coupler into the engine coupler. Be sure rubber coupler is properly mounted.

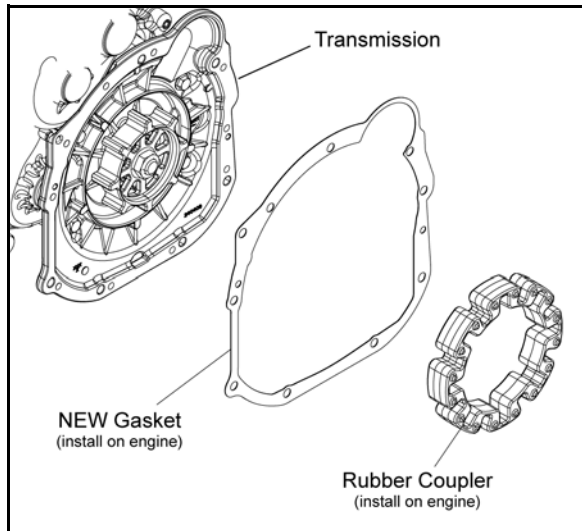

3. Install a new gasket onto the engine mounting surface.
4. Carefully place the transmission assembly into the chassis.



5. Slide the propshaft onto the transmission shaft.

6. Line up the engine and transmission couplers as shown.

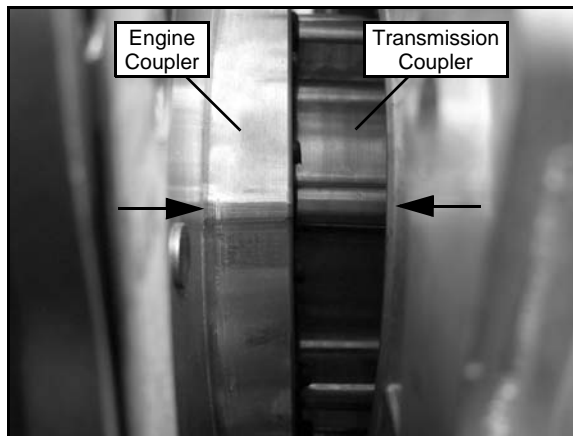

7. Slide the transmission forward to engage the couplers.

NOTE: Be sure the front propshaft is still attached to the transmission shaft before installing the bolts.

8. Start the (7) bolts that retain the transmission to the engine.



NOTE: Mount the engine-to-chassis ground with bolt as shown.

9. Torque the transmission to engine bolts in two steps to the specified torque value using a criss-cross pattern.

 = T
Transmission-to-Engine Retaining Bolts: 18 ft. lbs. (24 Nm)

10. Install the (2) through-bolt fasteners on the lower LH side and torque to specification.



T = T

**Transmission Through-Bolt Fasteners:
18 ft. lbs. (24 Nm)**

11. Install a **new** T45 mounting screw in the isolator mount on the lower RH side and torque to specification.

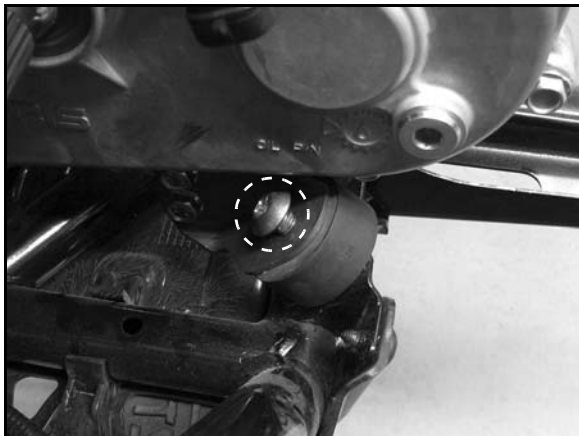

T = T

**Transmission Torx-Head Mounting Screw:
36 ft. lbs. (49 Nm)**

12. Install the upper RH frame support and torque fasteners to specification.

T = T

**Upper Right-Hand Frame Support Bolts:
36 ft. lbs. (49 Nm)**

13. Install the rear propshaft and torque the retaining bolts to specification.

T = T

**Rear Propshaft Bolts:
18 ft. lbs. (24 Nm)**

14. Reverse the transmission removal procedure to complete the installation.

15. Clean the drain plug magnetic surface.

16. Reinstall drain plug with a new O-ring and torque to specification.

17. Add the recommended amount of lubricant through the fill plug hole. Maintain the lubricant level at the bottom of the fill plug hole when filling the transmission. Do not overfill.

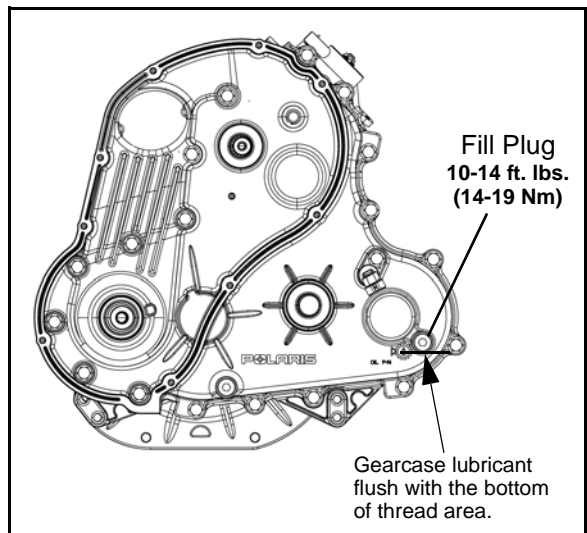

Oil = Gear

**Recommended Transmission Lubricant:
Synthetic Sportsman XP Transmission Fluid
(PN 2877606) (Quart)**

Capacity: 32 oz. (946 ml)

18. Reinstall fill plug with a new O-ring and torque to specification.

T = T

Drain/Fill Plug Torque: 10-14 ft. lbs. (14-19 Nm)

TRANSMISSION

Transmission Exploded View

FOR REASSEMBLY



Apply Polaris Crankcase Sealant.



Apply Loctite™ 2760 to the bolt threads.

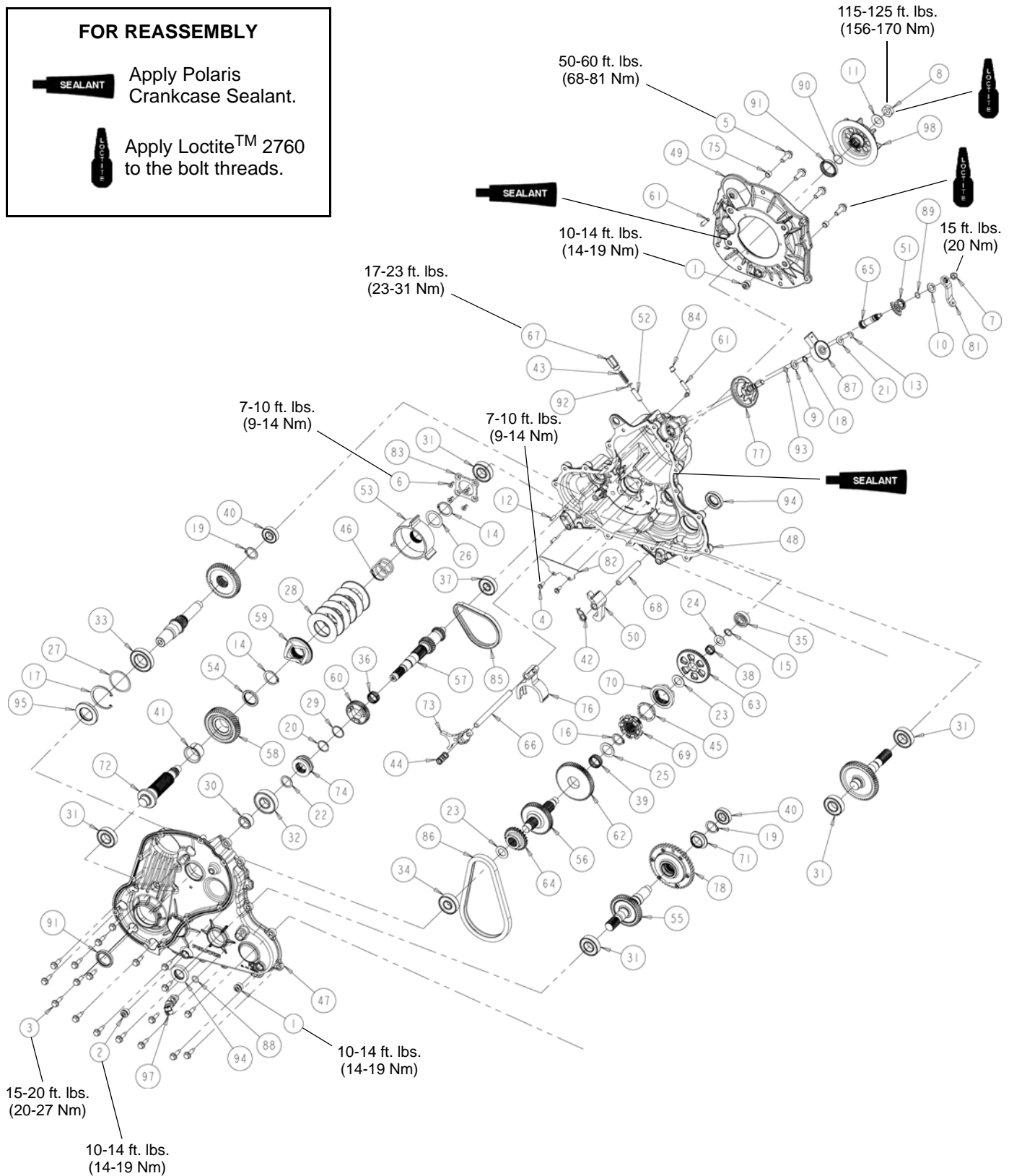

Exploded View, Continued.

Ref.	Qty.	Description	Ref.	Qty.	Description
1.	2	Plug, M18	48.	1	Gearcase, Main
2.	1	Plug w/Magnet, M18	49.	1	Bell Housing
3.	19	Screw, M8	50.	1	Park Pawl
4.	2	Screw, M6	51.	1	Gear, Sector 38T
5.	4	Screw, M10	52.	1	Detent Bullet
6.	4	Screw, M6	53.	1	Cup, Belleville
7.	1	Nut, Nylon Lock, 5/16-24	54.	1	Trust Spacer, Compensator
8.	1	Nut, M18	55.	1	Output Shaft
9.	1	Washer, Thrust	56.	1	Reverse Shaft, 53T
10.	1	Washer, Thrust	57.	1	Input Shaft, 25T
11.	1	Washer, Belleville	58.	1	Gear, Compensator
12.	2	Dowel Pin	59.	1	Cam, Compensator
13.	1	E-Ring	60.	1	Gear, Helical, 42T
14.	2	Retaining Ring	61.	2	Vent Tube
15.	1	Retaining Ring	62.	1	Gear, 67T
16.	1	Retaining Ring	63.	1	Sprocket, 48T
17.	1	Retaining Ring	64.	1	Sprocket, 23T
18.	1	Retaining Ring	65.	1	Shift Shaft, Bellcrank
19.	1	Retaining Ring	66.	1	Rail, Shift Shaft
20.	1	Retaining Ring	67.	1	Detent Plug
21.	1	Washer, Thrust	68.	1	Rail, Park Shaft
22.	1	Washer, Thrust	69.	1	Engagement Dog, Low
23.	2	Shim	70.	1	Engagement Dog, Reverse/Low
24.	1	Shim	71.	1	Bushing Sleeve
25.	1	Washer, Thrust	72.	1	Shaft, Compensator
26.	1	Shim	73.	1	Shift Fork
27.	1	Shim	74.	1	Engagement Dog, High
28.	6	Washer, Belleville	75.	2	Pipe, Knock
29.	1	Washer, Thrust	76.	1	Shift Fork
30.	1	Collar	77.	1	Switch Shaft
31.	3	Ball Bearing	78.	1	PTL, Subassembly
32.	1	Ball Bearing	81.	1	Bellcrank, 15T Spline
33.	1	Ball Bearing	82.	1	Oil Deflector
34.	1	Ball Bearing	83.	1	Bearing Cover
35.	1	Ball Bearing	85.	1	Silent Chain
36.	1	Needle Bearing	86.	1	Silent Chain
37.	1	Ball Bearing	87.	1	Switch, Rotary
38.	1	Needle Bearing	88.	1	O-Ring
39.	1	Needle Bearing	89.	1	O-Ring
40.	1	Ball Bearing	90.	1	O-Ring
41.	1	Flanged Bearing	91.	2	Seal, Triple Lip
42.	1	Torsion Spring, Park Pawl	92.	1	O-Ring
43.	1	Compression Spring	93.	1	O-Ring
44.	1	Compression Spring	94.	2	Seal, Triple Lip
45.	1	Wave Spring	95.	1	Seal, Triple Lip
46.	1	Compression Spring	97.	1	Speed Sensor
47.	1	Gearcase, Cover	98.	1	Coupler

TRANSMISSION

TROUBLESHOOTING

Troubleshooting Checklist

Check the following items when shifting difficulty is encountered.

- Engine idle speed is above specification
- Transmission fluid type/quality
- Loose or worn snap linkage bushings
- Worn linkage rod pivot end at the transmission bellcrank
- Bent bellcrank
- Worn, broken or damaged internal transmission components

NOTE: To determine if shifting difficulty is caused by an internal transmission problem, isolate the transmission by disconnecting linkage rod from transmission bellcrank. Manually select each gear range at the transmission bellcrank and test ride vehicle. If it functions properly, the problem is outside the transmission.

If transmission problem remains, disassemble transmission and inspect all gear dogs for wear (rounding), or damage. Inspect all bearings, circlips, thrust washers and shafts for wear.

CHAPTER 7

CLUTCHING (PVT)

SPECIAL TOOLS AND SUPPLIES	7.2
TORQUE SPECIFICATIONS	7.2
PVT SYSTEM OVERVIEW	7.2
GENERAL OPERATION	7.2
DRIVE CLUTCH OPERATION	7.2
SHIFT WEIGHTS	7.3
DRIVEN CLUTCH OPERATION	7.3
PVT BREAK-IN (DRIVE BELT / CLUTCHES)	7.3
MAINTENANCE / INSPECTION	7.3
OVERHEATING / DIAGNOSIS	7.4
PVT SYSTEM SERVICE	7.5
PVT SEALING AND DUCTING COMPONENTS	7.5
DISASSEMBLY	7.6
ASSEMBLY	7.7
DRIVE BELT	7.9
BELT REMOVAL	7.9
BELT INSPECTION	7.10
BELT INSTALLATION	7.10
PVT BREAK-IN (DRIVE BELT / CLUTCHES)	7.10
DRIVE CLUTCH SERVICE	7.11
SPRING SPECIFICATIONS	7.11
EXPLODED VIEW	7.12
CLUTCH DISASSEMBLY	7.12
SPIDER REMOVAL	7.13
ROLLER, PIN, AND THRUST WASHER INSPECTION	7.14
BUTTON TO TOWER CLEARANCE INSPECTION	7.14
SHIFT WEIGHT INSPECTION	7.14
BEARING INSPECTION	7.15
CLUTCH INSPECTION	7.15
MOVEABLE SHEAVE BUSHING INSPECTION	7.16
BUSHING SERVICE	7.17
CLUTCH ASSEMBLY	7.19
DRIVEN CLUTCH SERVICE	7.20
CLUTCH DISASSEMBLY	7.20
BUSHING SERVICE	7.22
CLUTCH ASSEMBLY	7.24
EXPLODED VIEW	7.27
TROUBLESHOOTING	7.28

CLUTCHING (PVT)

SPECIAL TOOLS AND SUPPLIES

TOOL DESCRIPTION	PART NUMBER
Drive Clutch Puller (Short)	PA-48595
Clutch Holding Wrench	9314177
Clutch Holding Fixture	2871358-A
Drive Clutch Spider Removal and Installation Tool	2870341
Roller Pin Tool	2870910
Clutch Bushing Replacement Tool Kit	2871226
Piston Pin Puller	2870386
Clutch Compression Tool	8700220
Clutch Bushing Replacement Tool Kit	2871025

SPECIAL SUPPLIES	PART NUMBER
Loctite™ 609	N/A
RTV Silicone Sealer	8560054

TORQUE SPECIFICATIONS

PVT System Fastener Torques

ITEM	TORQUE VALUE
Drive Clutch Spider	200 ft. lbs. (271 Nm)
Drive Clutch Retaining Bolt	47 ft. lbs. (64 Nm) Left Hand Thread
Driven Clutch Retaining Bolt	13 ft. lbs. (18 Nm)
Drive Clutch Cover Bolts	100 in. lbs. (11 Nm)
Inner PVT Cover Screws	6-8 ft. lbs. (8-11 Nm)
Outer PVT Cover Screws	45-50 in. lbs. (5-5.6 Nm)
Drive Clutch Weight Pins	15-25 in. lbs. (2-3 Nm)

PVT SYSTEM OVERVIEW

General Operation

**WARNING**

All PVT maintenance or repairs should be performed by a certified Polaris Master Service Dealer (MSD) technician who has received the proper training and understands the procedures outlined in this manual. **Because of the critical nature and precision balance incorporated into the PVT components, it is absolutely essential that no disassembly or repair be made without factory authorized special tools and service procedures.**

The Polaris Variable Transmission (PVT) consists of three major assemblies:

- 1) **The Drive Clutch**
- 2) **The Driven Clutch**
- 3) **The Drive Belt**

The internal components of the drive clutch and driven clutch control engagement (initial vehicle movement), clutch upshift and backshift. During the development of a Polaris ATV, the PVT system is matched first to the engine power curve; then to average riding conditions and the vehicle's intended usage. Therefore, modifications or variations of components at random are never recommended. Proper clutch setup and careful inspection of existing components must be the primary objective when troubleshooting and tuning.

Drive Clutch Operation

Drive clutches primarily sense engine RPM. The two major components which control its shifting function are the shift weights and the coil spring. Whenever engine RPM is increased, centrifugal force is created, causing the shift weights to push against rollers on the moveable sheave, which is held open by coil spring preload. When this force becomes higher than the preload in the spring, the outer sheave moves inward and contacts the drive belt. This motion pinches the drive belt between the spinning sheaves and causes it to rotate, which in turn rotates the driven clutch.

At lower RPM, the drive belt rotates low in the drive clutch sheaves. As engine RPM increases, centrifugal force causes the drive belt to be forced upward on drive clutch sheaves.

Shift Weights

Shift weights have many factors designed into them for controlling engagement RPM and shifting patterns. Shift weights should not be changed or altered without first having a thorough understanding of their positioning and the effects they may have on belt to sheave clearance, clutch balance and shifting pattern.

Driven Clutch Operation

Driven clutches primarily sense torque, opening and closing according to the forces applied to it from the drive belt and the transmission input shaft. If the torque resistance at the transmission input shaft is greater than the load from the drive belt, the drive belt is kept at the outer diameter of the driven clutch sheaves.

As engine RPM and horsepower increase, the load from the drive belt increases, resulting in the belt rotating up toward the outer diameter of the drive clutch sheaves and downward into the sheaves of the driven clutch. This action, which increases the driven clutch speed, is called upshifting.

Should the throttle setting remain the same and the vehicle is subjected to a heavier load, the drive belt rotates back up toward the outer diameter of the driven clutch and downward into the sheaves of the drive clutch. This action, which decreases the driven clutch speed, is called backshifting.

In situations where loads vary (such as uphill and downhill) and throttle settings are constant, the drive and driven clutches are continually shifting to maintain optimum engine RPM. At full throttle a perfectly matched PVT system should hold engine RPM at the peak of the power curve. This RPM should be maintained during clutch upshift and backshift. In this respect, the PVT system is similar to a power governor. Rather than vary throttle position, as a conventional governor does, the PVT system changes engine load requirements by either upshifting or backshifting.

PVT Break-In (Drive Belt / Clutches)

A proper break-in of the clutches and drive belt will ensure a longer life and better performance. Break in the clutches and drive belt by operating at slower speeds during the 10 hour break-in period as recommended (see Chapter 5 "Engine Break-In Period" for break-in example). Pull only light loads. Avoid aggressive acceleration and high speed operation during the break-in period.

Maintenance / Inspection

Under normal use the PVT system will provide years of trouble free operation. Periodic inspection and maintenance is required to keep the system operating at peak performance. The following list of items should be inspected and maintained to ensure maximum performance and service life of PVT components. Refer to the troubleshooting checklist at the end of this chapter for more information.

- Belt Inspection
- Drive and Driven Clutch Buttons and Bushings
- Drive Clutch Shift Weights and Pins
- Drive Clutch Spider Rollers and Roller Pins
- Drive and Driven Clutch Springs
- Sheave Faces (clean and inspect for wear)
- PVT System Sealing. Refer to appropriate illustrations on the following pages. The PVT system is air cooled by fins on the drive clutch stationary sheave. The fins create a low pressure area in the crankcase casting, drawing air into the system through an intake duct. The opening for this intake duct is located at a high point on the vehicle (location varies by model). The intake duct draws fresh air through a vented cover. All connecting air ducts (as well as the PVT cover) must be properly sealed to ensure clean air is being used for cooling the PVT system and also to prevent water and other contaminants from entering the PVT area. This is especially critical on units subjected to frequent water forging.

CLUTCHING (PVT)

Overheating / Diagnosis

During routine maintenance, or whenever PVT system overheating is evident, it's important to check the inlet *and* outlet ducting for obstructions. Obstructions to air flow through the ducts will significantly increase PVT system operating temperatures. The vehicle should be operated in Low when plowing or pulling heavy loads, or if extended low speed operation is anticipated.

CLUTCH DRIVE BELT & COVER RELATED ISSUES: DIAGNOSIS	
Possible Causes	Solutions / What to do
Loading the vehicle into a truck or tall trailer when in high range.	Shift transmission to Low during loading of the vehicle to prevent belt burning.
Starting out going up a steep incline from a stopped position.	When starting out on an incline, use Low, or dismount the vehicle after first applying the park brake and perform the "K" turn.
Driving at low RPM or low ground speed (at approximately 3-7 MPH).	Drive at higher speed or use Low. The use of Low is highly recommended for cooler PVT operating temperatures and longer component life.
Insufficient warm-up of Utility Task Vehicles™ exposed to low ambient temperatures.	Warm engine at least 5 min., then with transmission in neutral, advance throttle to approx. 1/8 throttle in short bursts, 5 to 7 times. The belt will become more flexible and prevent belt burning.
Slow and easy clutch engagement.	Fast, effective use of the throttle for efficient engagement.
Towing/Pushing at low RPM/low ground speed.	Use Low only.
Plowing snow, dirt, etc./utility use.	Use Low only.
Stuck in mud or snow.	Shift the transmission to Low, carefully use fast, aggressive throttle application to engage clutch. WARNING: Excessive throttle may cause loss of control and vehicle overturn.
Climbing over large objects from a stopped position.	Shift the transmission to Low, carefully use fast, aggressive, brief throttle application to engage clutch. WARNING: Excessive throttle may cause loss of control and vehicle overturn.
Belt slippage from water or snow ingestion into the PVT system.	Shift the transmission to neutral. Using the throttle, vary the engine rpm from idle to full throttle. Repeat several times as required. During this procedure, the throttle should not be held at the full position for more than 10 seconds. Clutch seals should be inspected for damage if repeated leaking occurs.
Clutch malfunction.	For inspection of clutch components, please contact your Polaris dealer. Shift transmission to Low during loading of the vehicle to prevent belt burning.
Poor engine performance.	Fouled plugs, foreign material in gas tank, fuel lines, or carburetor. Contact you dealer for further service information.
GENERAL RANGE OPERATION GUIDELINES:	Low: Heavy pulling, basic operational speeds less than 7 MPH, riding through rough terrain (swamps, mountains, ect.), low ground speeds.
	High: High ground speeds, speeds above 7 MPH.

IMPORTANT: Using High Gear when pulling heavy loads, operating on hilly terrain, or in wet, muddy conditions will increase the chance of drive belt damage.

PVT SYSTEM SERVICE

PVT Sealing and Ducting Components

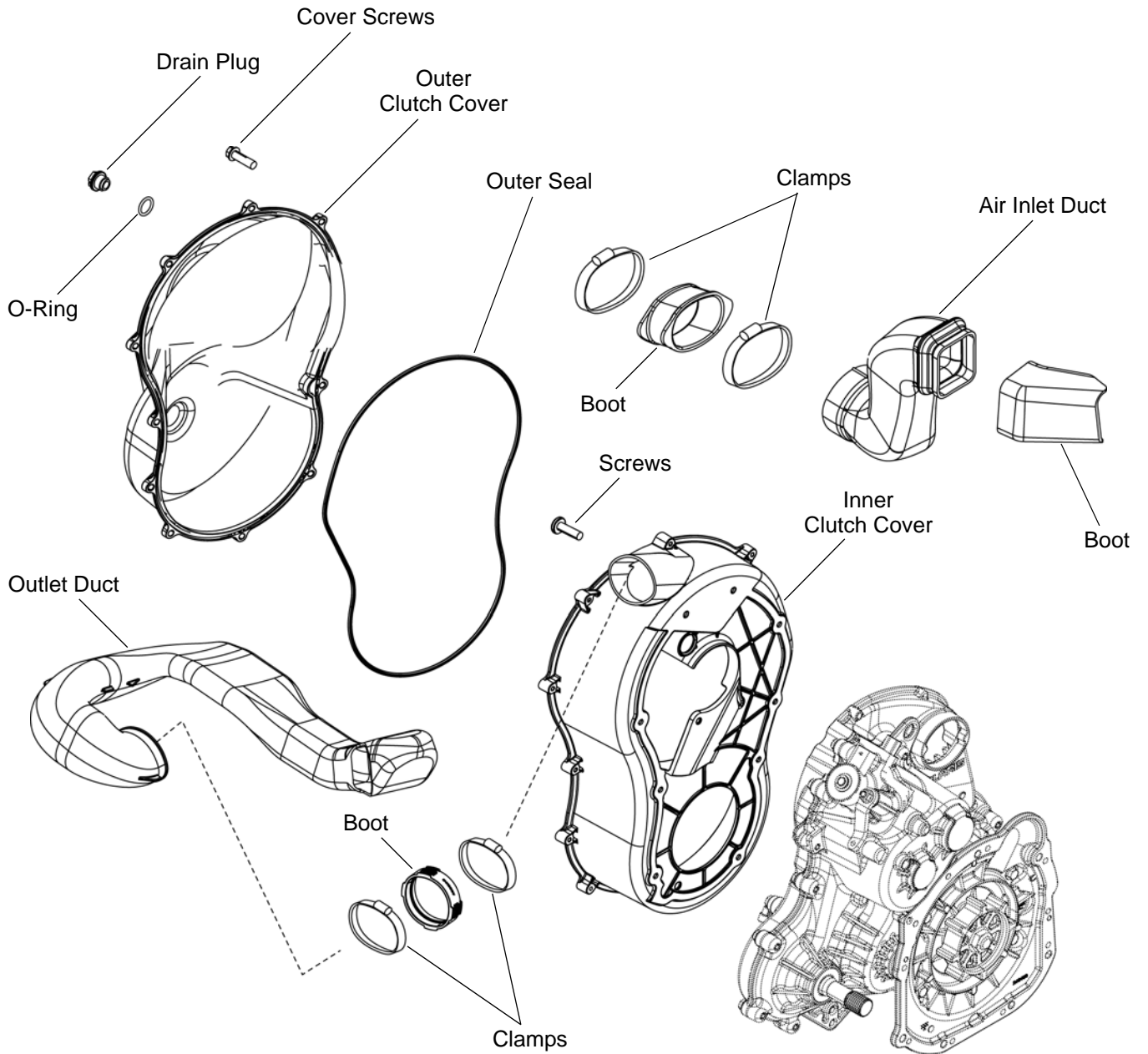

CLUTCHING (PVT)

Disassembly

Some fasteners and procedures will vary. Refer to the appropriate parts manual for proper fastener placement.

1. Remove the left rear wheel and lower left-hand frame support (see "DRIVE BELT - Belt Removal", steps 1-4).
2. Remove the (10) push rivets and (4) Torx-headed screws retaining the rear cab assembly.

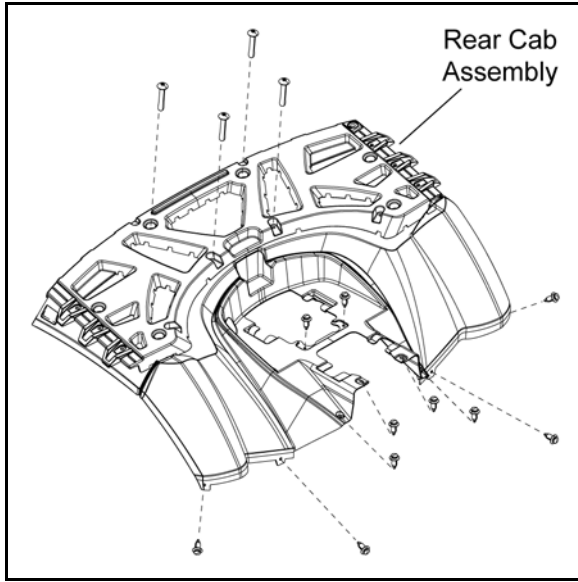

3. Remove the tail light bulbs from the tail lamps, disconnect the tail light harnesses from the rear cab, and remove the rear cab to allow access to the PVT system for disassembly.

4. Remove the (11) screws retaining the outer PVT cover.

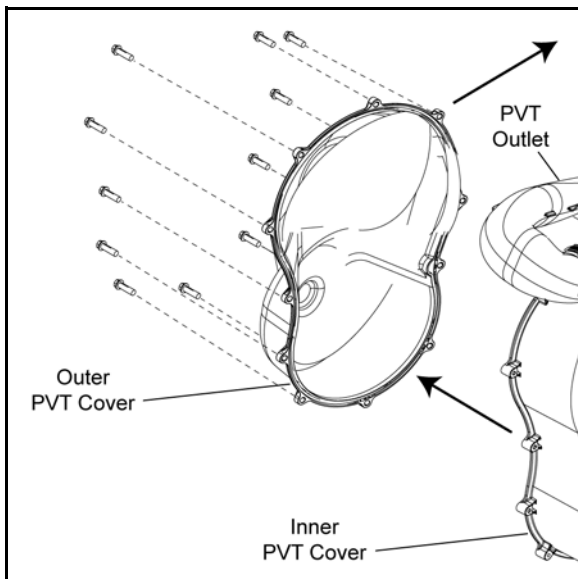

5. Using care, pull the outer PVT cover out the left-hand wheel well.

6. Mark the drive belt direction of rotation and remove drive belt (see "DRIVE BELT - Belt Removal", steps 8-10).
7. Loosen the clamps and remove the PVT outlet duct from the inner PVT cover.

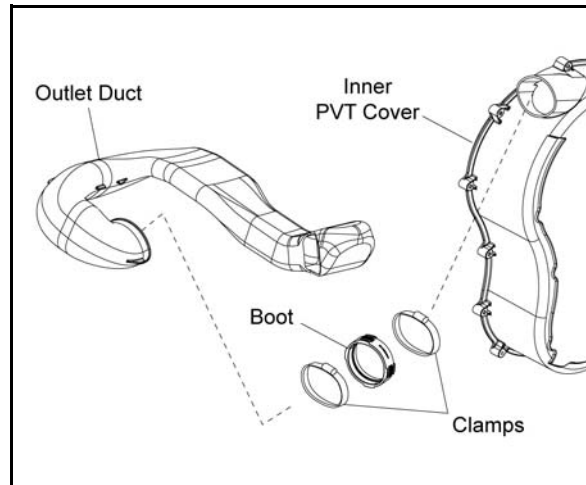

8. Rotate and remove the PVT outlet duct from the vehicle to allow for driven clutch removal.

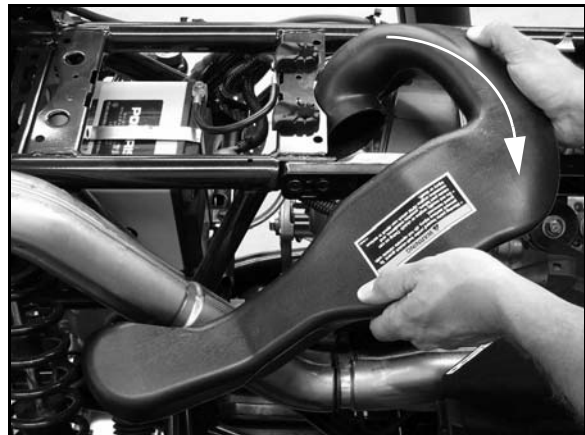

9. Remove the driven clutch retaining bolt and driven clutch.



10. Install the Drive Clutch Holder (PN 9314177) onto the drive clutch.

Drive Clutch Holder (9314177)

11. Remove the drive clutch retaining bolt by turning the bolt in a **clockwise** direction.



NOTE: The drive clutch retaining bolt has left-hand threads. Turn the bolt clockwise to remove it.

12. Insert the Drive Clutch Puller (PA-48595) into the drive clutch and use it to remove the clutch from the shaft.

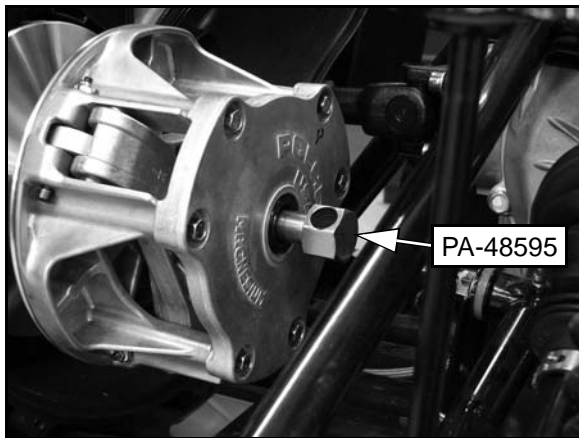

Drive Clutch Puller (PA-48595)

13. Remove the (10) screws that retain the inner PVT cover to the transmission case and remove the cover.

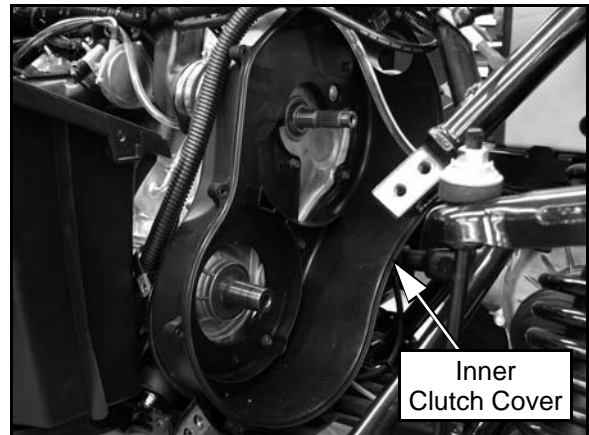

14. Remove the old silicone material from the inner PVT cover and transmission case using a wire brush. Clean both surfaces thoroughly in preparation for assembly.

Assembly

1. Inspect the inner PVT cover. Replace if cracked or damaged. The mating surface must be clean to ensure adhesion of new silicone sealant.
2. Be sure to “flame treat” the inner PVT cover prior to applying silicone to ensure good adhesion. Pass the flame of a propane torch back and forth quickly over the area where the silicone is to be applied (2-3 inches from the flame tip is recommended). Do not hold the torch too close to the surface. Keep the torch moving to prevent damage.
3. Apply RTV silicone sealant to the outside edge of the inner PVT cover to ensure a water tight fit between the cover and the transmission.

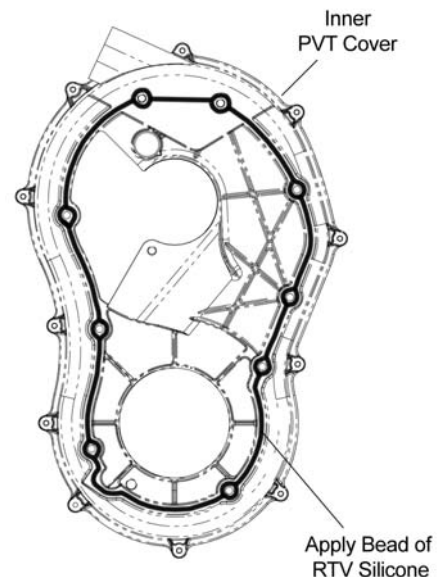

CLUTCHING (PVT)

4. Install the cover and torque the inner PVT cover screws to specification.

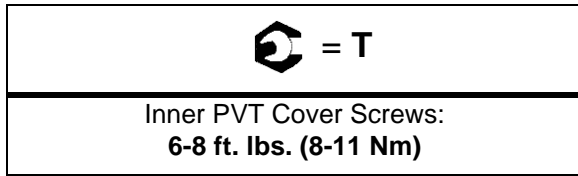

5. Wipe away any excess silicone sealant.
6. Clean the splines inside the driven clutch and on the transmission input shaft.
7. Apply a light film of grease to the splines on the shaft.
8. Install the driven clutch, cup washer, lock washer, and retaining bolt. Torque retaining bolt to specification.

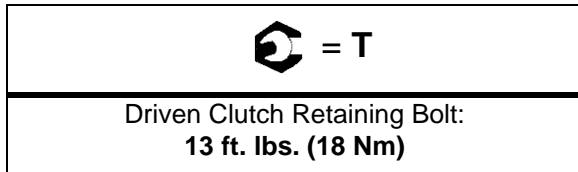

9. Clean end of taper on crankshaft and the taper bore inside drive clutch using a tapered reamer.
10. Install the drive clutch, bushing, washer, lock washer, and the left-hand threaded retaining bolt. Torque retaining bolt to specification.

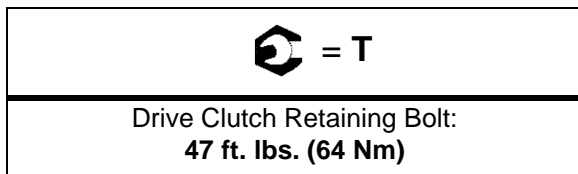

11. Install drive belt noting direction of rotation if the belt is being reused (see "DRIVE BELT - Belt Installation", steps 1-3).
12. Install the PVT outlet duct. Align the duct with the inner PVT cover properly before tightening the hose clamps.

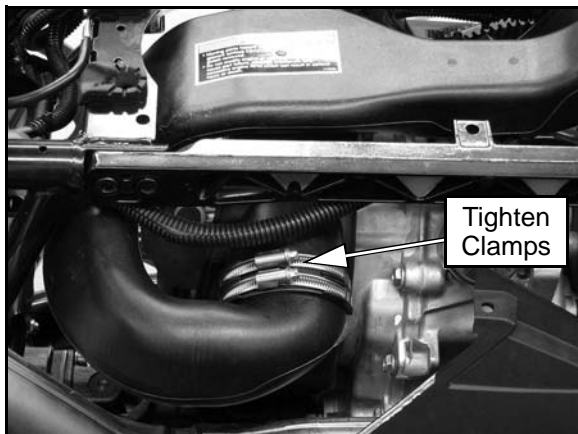

13. Replace the outer PVT cover seal.

14. Reinstall outer PVT cover and secure with screws. Torque screws to specification.

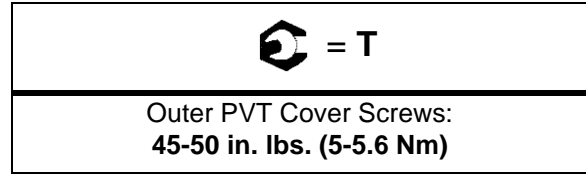

15. Reinstall the rear cab, tail light bulbs, and fasteners.

16. Reinstall the lower left-hand frame support and torque bolts to specification.

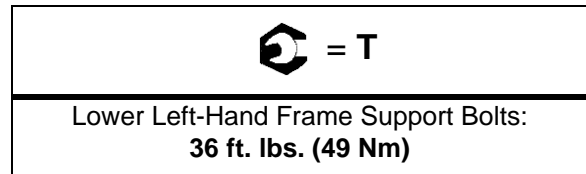

17. Install the left rear wheel and torque wheel nuts to specification.

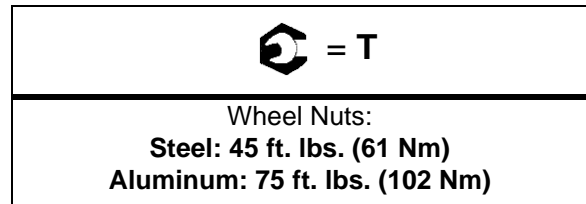

18. Lower the ATV, start the engine, and test the operation of the PVT system.

DRIVE BELT**Belt Removal**

1. Position the vehicle on a level surface and place the transmission in Park.
2. Elevate and safely support the rear of the vehicle.
3. Remove the left rear wheel from the vehicle.
4. Remove the (4) bolts retaining the lower left-hand frame support and remove it from the frame.

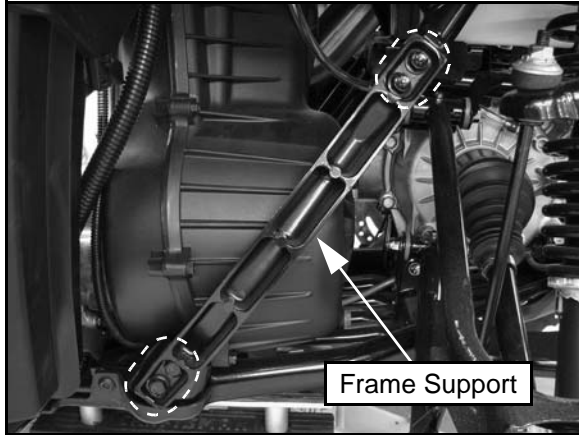

5. Remove the (11) screws retaining the PVT cover.

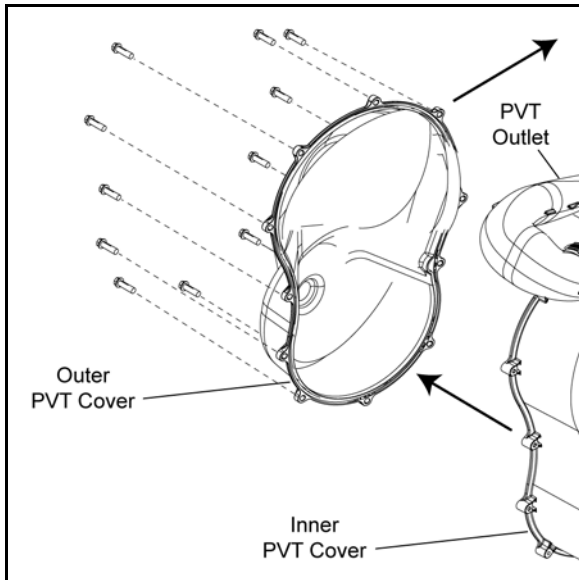

6. Using care, pull the PVT cover out the left-hand wheel well.
7. Mark the drive belt direction of rotation so that it can be installed in the same direction.

8. Insert the belt removal tool PN 2877408 into the driven clutch as shown (tool included with vehicle's tool kit).

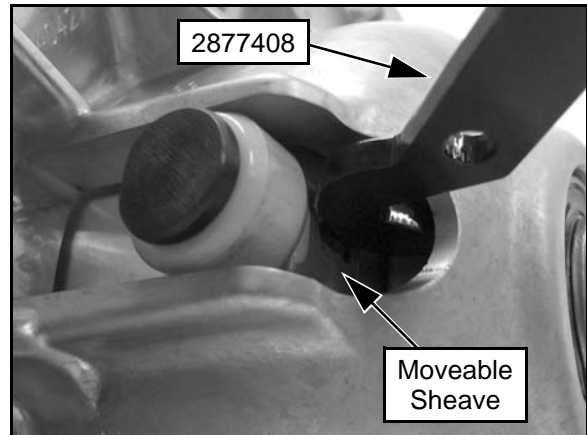

NOTE: Make sure the tool is square with the moveable sheave surface of the driven clutch.

9. Rotate the tool towards the clutch to open the sheaves.

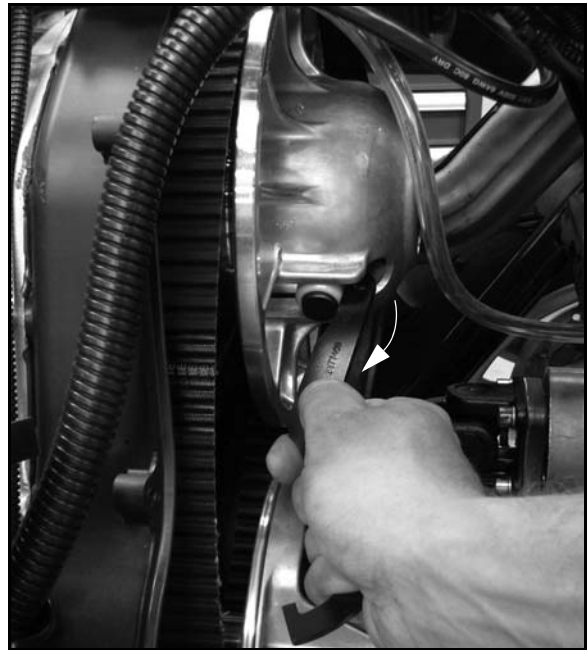

10. Walk the belt out of the driven clutch and drive clutch, and remove it from the vehicle.

IMPORTANT: Leave the Belt Removal Tool installed for belt installation.

CLUTCHING (PVT)

Belt Inspection

1. Inspect belt for hour glassing (extreme circular wear in at least one spot and on both sides of the belt). Hour glassing occurs when the drive train does not move and the drive clutch engages the belt.
2. Inspect belt for loose cords, missing cogs, cracks, abrasions, thin spots, or excessive wear. Compare belt measurements with a new drive belt. Replace if necessary.
3. Belts with thin spots, burn marks, etc., should be replaced to eliminate noise, vibration, or erratic PVT operation. See the Troubleshooting Chart at the end of this chapter for possible causes.

Belt Installation

1. If the Belt Removal Tool was removed without the belt installed, you must rotate the clutch and insert the tool at the 6 o'clock position.



2. With the Belt Removal Tool installed, loop the belt over the drive clutch and over top of the driven sheaves.

NOTE: Be sure to install the drive belt as shown, so the "Polaris" label can be read .



3. Rotate the driven sheave and walk the belt into the driven clutch.
4. Replace the outer PVT cover seal.
5. Reinstall outer PVT cover and secure with screws. Torque screws to specification.

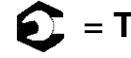

Outer PVT Cover Screws:
45-50 in. lbs. (5-5.6 Nm)

6. Reinstall the lower left-hand frame support and torque bolts to specification.



Lower Left-Hand Frame Support Bolts:
36 ft. lbs. (49 Nm)

7. Install the left rear wheel and torque wheel nuts to specification.



Wheel Nuts:
Steel: 45 ft. lbs. (61 Nm)
Aluminum: 75 ft. lbs. (102 Nm)

8. Lower the ATV, start the engine, and test the operation of the PVT system.

PVT Break-In (Drive Belt / Clutches)

A proper break-in of the clutches and drive belt will ensure a longer life and better performance. Break in the clutches and drive belt by operating at slower speeds during the 10 hour break-in period as recommended (see Chapter 5 "Engine Break-In Period" for break-in example). Pull only light loads. Avoid aggressive acceleration and high speed operation during the break-in period.

DRIVE CLUTCH SERVICE

Spring Specifications

The drive clutch spring has two primary functions:

1. To control clutch engagement RPM. The springs, which have a higher rate when the clutch is in neutral, will increase clutch engagement RPM.
2. To control the rate at which the drive belt moves upward in the drive clutch sheaves. This is referred to as drive clutch upshift.

There are other components which control upshift, but the spring is one of the primary components in insuring optimum performance. It is very important that the spring is of the correct design and is in good condition.

 **CAUTION**

Never shim a drive clutch spring to increase its compression rate. This may result in complete stacking of the coils and subsequent clutch cover failure.

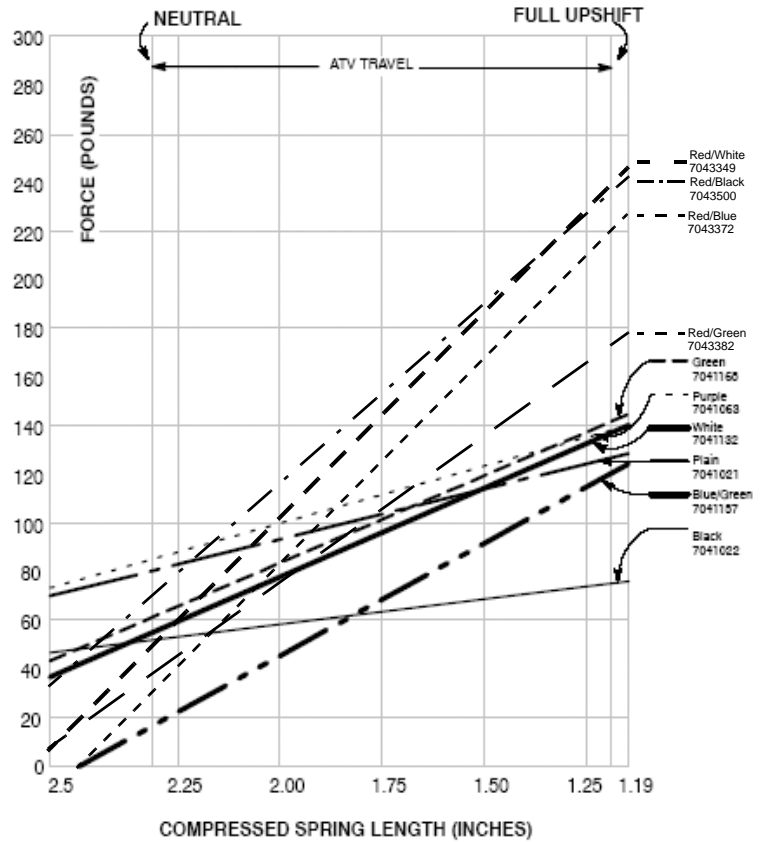

The drive clutch spring is one of the most critical components of the PVT system. It is also one of the easiest to service. Due to the severe relaxation the spring is subject to during operation, it should always be inspected for tolerance limits during any clutch operation diagnosis or repair.

With the spring resting on a flat surface, measure its free length from the outer coil surfaces as shown. Refer to the spring specification chart for specific free length measurements and tolerances. Also check to see that spring coils are parallel to one another. Distortion of the spring indicates stress fatigue, requiring replacement.



Primary Clutch Springs

PART NUMBER	COLOR CODE	WIRE DIAMETER	FREE LENGTH ± .125"	PART NUMBER	COLOR CODE	WIRE DIAMETER	FREE LENGTH ± .125"
7041021	Plain	.157"	4.38"	7041168	Green	.177"	3.05"
7041022	Black	.140"	4.25"	7043349	Red / White	.200"	2.58"
7041063	Purple	.168"	4.37"	7043372	Red / Blue	.187"	2.56"
7041132	White	.177"	2.92"	7043382	Red / Green	.177"	2.63"
7041157	Blue / Green	.177"	2.53"	7043500	Red / Black	.200"	2.82"

CLUTCHING (PVT)

Exploded View

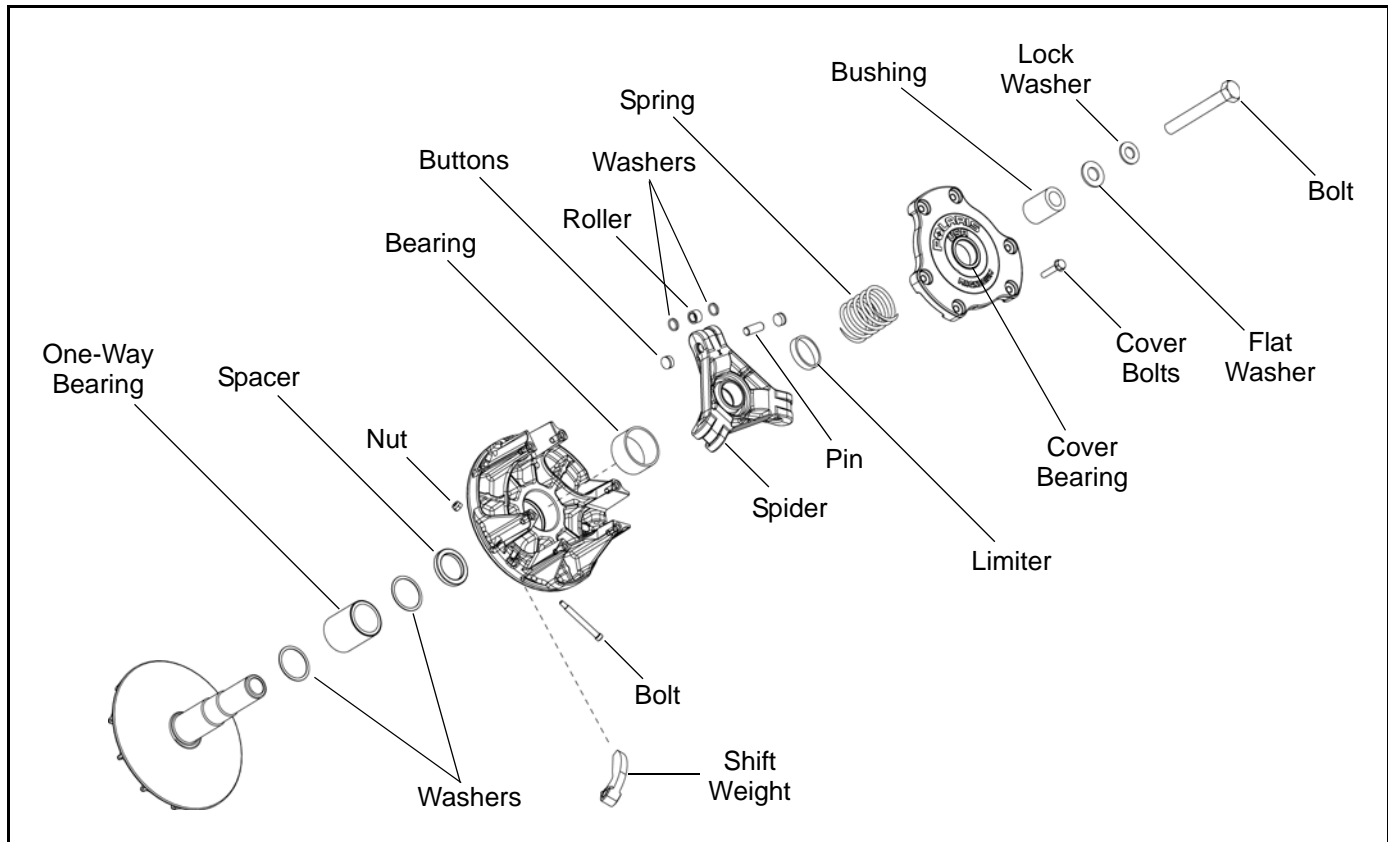

Clutch Disassembly

1. Using a permanent marker, mark the cover, spider, and moveable and stationary sheaves for reference, as the cast in X's may not have been in alignment before disassembly.



2. Mark the stationary sheave and clutch shaft to verify the shaft has not turned in the sheave after tightening the spider during clutch assembly.
3. Remove cover bolts evenly in a cross pattern and remove cover plate.

4. Inspect cover bushing (A). The outer cover bushing is manufactured with a Teflon™ coating. Wear is determined by the amount of Teflon™ remaining on the bushing.

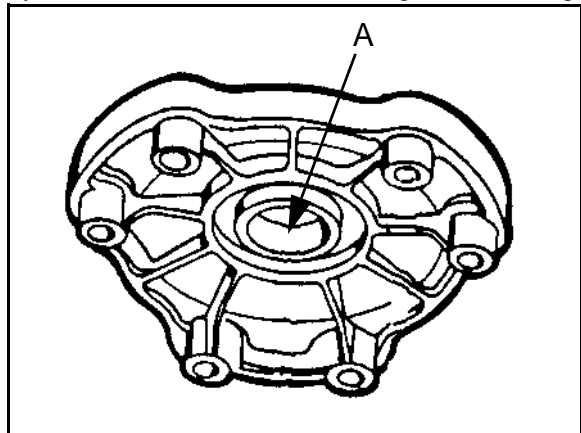

Cover Bushing Inspection:
 Replace the cover bushing if more brass than Teflon™ is visible on the bushing. Refer to bushing replacement in this chapter.

5. Inspect area on shaft where bushing rides for wear, galling, nicks, or scratches. Replace clutch assembly if worn or damaged.

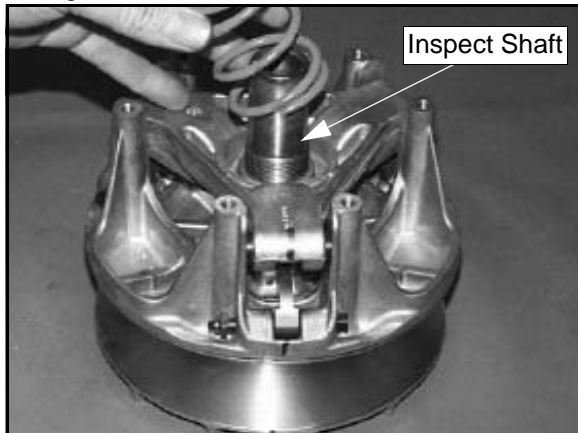

6. Remove and inspect the clutch spring. See "Drive Clutch Spring Specifications" for spring inspection.

Spider Removal

1. Remove the limiter spacer from the shaft.
2. Install clutch in holding fixture (PN 2871358-A).
NOTE: This updated holding fixture is required to fit the new drive clutch with a curved rib design.

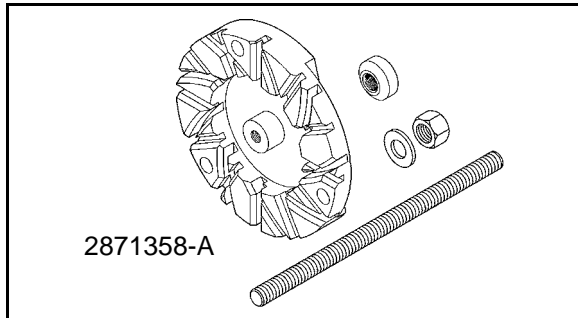

3. Loosen the spider (clockwise) using Clutch Spider Removal Tool (PN 2870341).

IMPORTANT: The clutch shaft has left-hand threads. Be sure to turn the Spider Removal Tool in a clockwise direction to remove.



NOTE: It is important that the same number and thickness of washers are reinstalled beneath the spider during assembly. Be sure to note the number and thickness of these washers.

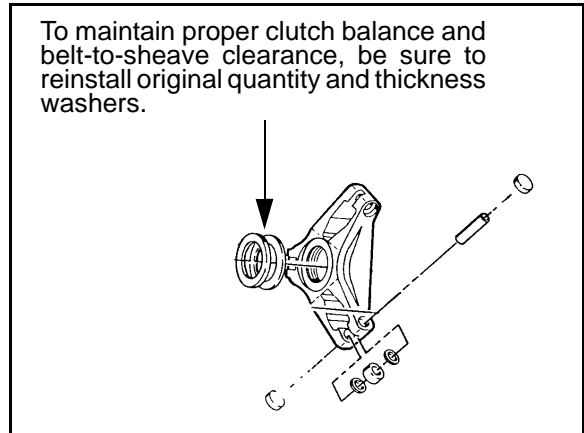

Moveable Sheave Bushing Inspection

4. Inspect the Teflon™ coating on the moveable sheave bushing.

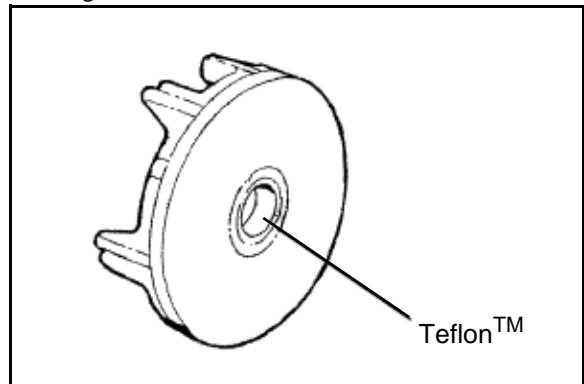

Moveable Sheave Bushing Inspection:
Replace the cover bushing if more brass than Teflon is visible on the bushing. Refer to bushing replacement in this chapter.

CLUTCHING (PVT)

Roller, Pin, and Thrust Washer Inspection

1. Inspect all rollers, bushings and roller pins by pulling a flat metal rod across the roller. Turn roller with your finger. If you notice resistance, galling, or flat spots, replace rollers, pins and thrust washers in sets of three. Also inspect to see if roller and bushing are separating. Bushing must fit tightly in roller. Use the Roller Pin Tool (PN 2870910) to replace rollers and pins. Take care not to damage roller bushing or bearing surface of the new pin during installation.

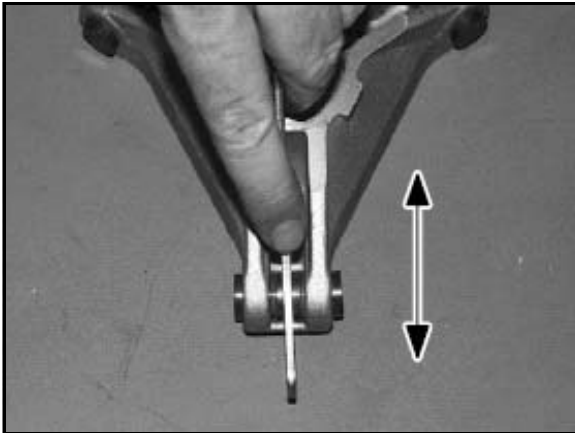

2. Rubber backed buttons can be used in all clutches if the hollow roller pin is changed to the solid roller pin.

NOTE: The rubber side of the button is positioned toward the solid roller pin.

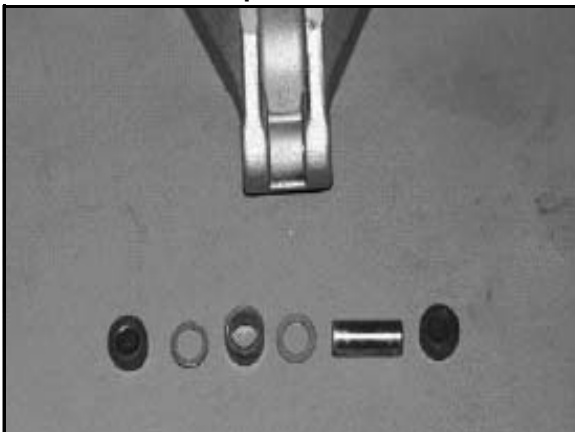

Button To Tower Clearance Inspection

1. Inspect for any clearance between spider button to tower. If clearance exists, replace all buttons and inspect surface of towers. See "Spider Removal" procedure.



**Button to Tower Clearance:
000-.001"**

2. Inspect sheave surfaces. Replace the entire clutch if worn, damaged or cracked.

Shift Weight Inspection

⚠ WARNING

The clutch assembly is a precisely balanced unit. Never replace parts with used parts from another clutch assembly!

1. If clutch is not disassembled, inspect as shown, using a clutch holding tool to compress the moveable sheave. The contact surface of the weight should be smooth and free of dents or gall marks.



- Remove shift weight bolts and weights. Inspect the contact surface of the weight. The surface should be smooth and free of dents or gall marks. Inspect the weight pivot bore and pivot bolts for wear or galling. If weights or bolts are worn or broken, replace in sets of three with new bolts.

NOTE: A damaged shift weight is usually caused by a damaged or stuck roller in the spider assembly. See "Roller, Pin and Thrust Washer Inspection".

Bearing Inspection

- Rotate the clutch bearing in both clockwise and counter-clockwise directions. The one-way bearing should rotate counter-clockwise (when viewed from cover plate side) with only a slight amount of drag. When rotated clockwise the one-way bearing should lock to the shaft without slipping.
- Verify there is no binding or rough spots. If problems are noted continue with disassembly.

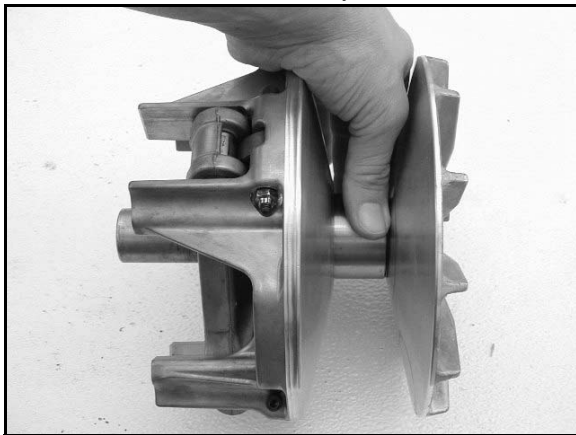

Clutch Inspection

NOTE: Remove cover, spring, and spider following instructions for drive clutch removal, then proceed as follows:

- Remove the moveable sheave spacer sleeve (1) and the thrust washer (2). Visually inspect the washer for damage.
- Measure the thickness and compare to specification. Replace if worn or damaged.

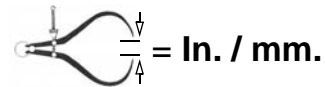
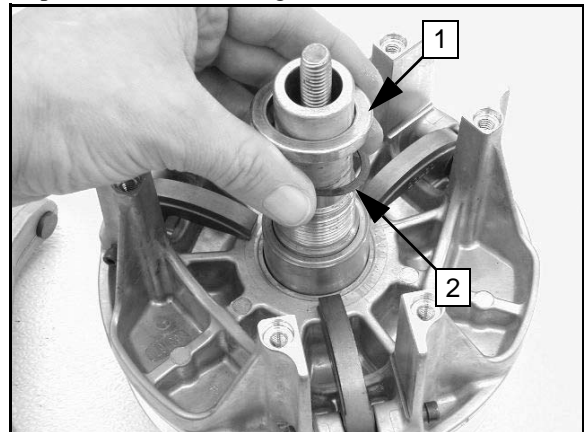

Thrust Washer Thickness
Standard: .030" (.76mm)
Service Limit: .025" (.64mm)

- Remove the moveable clutch sheave.
- Lift bearing (3) and thrust washer (4) off shaft. Replace as an assembly if worn, damaged, or if problems were noted.

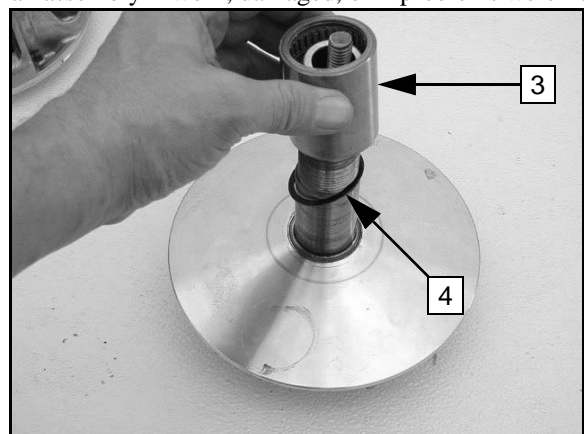

CLUTCHING (PVT)

- Inspect surface of shaft for pitting, grooves, or damage. Measure the outside diameter and compare to specifications. Replace the drive clutch assembly if shaft is worn or damaged.

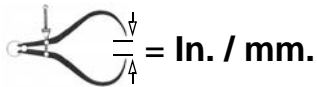

Shaft Diameter:
Standard: 1.3745 - 1.375 (
Service Limit: 1.3730"

- Visually inspect PTFE thrust washer for damage. Measure the thickness and compare to specification. Replace if worn or damaged.

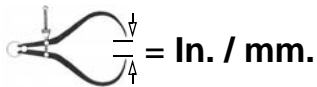

PTFE Washer Thickness
Standard: .030" (.76mm)
Service Limit: .025" (.64mm)

Moveable Sheave Bushing Inspection

Inspect the Teflon™ coating (arrow) on the moveable sheave bushing. Inspect both sheaves for signs of wear, grooving or cracking. De-glaze sheave surfaces with a 3M™ Scotch-Brite Pad if needed.



Moveable Sheave Bushing Inspection:
Replace the cover bushing if more brass
than Teflon™ is visible on the bushing.
Refer to bushing replacement
in this chapter.

Bushing Service

IMPORTANT: Special Tools Required

EBS Clutch Bushing Tool Kit - 2201379

Item	Qty.	Part Description	Part #
A, B	1	EBS Puller Tool	5132027
C	1	EBS Puller Nut	5132501
D	1	EBS Main Adapter	5132029
E	1	EBS Bushing Removal Tool	5132028
--	1	Instructions	9915111

Additional Special Tools

Qty.	Part Description	Part #
1	Clutch Bushing Replacement Tool Kit	2871226
1	Piston Pin Puller	2870386

***Clutch Bushing Replacement Tool Kit (PN 2871226)**

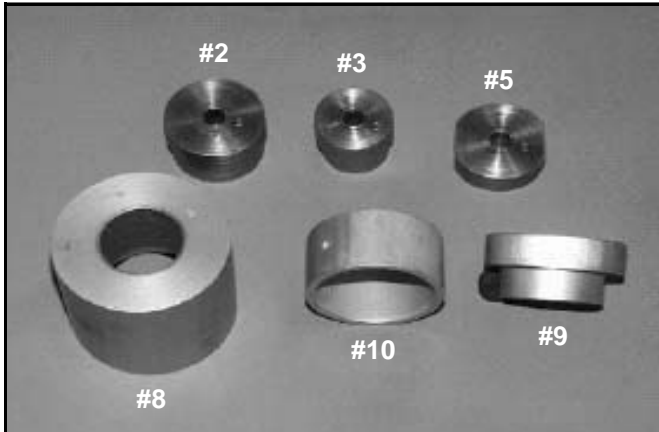

Item	Qty.	Part Description	Part #
#2	1	P-90 Drive/Driven Clutch Bushing Install Tool	5020628
#3	1	Drive Clutch Cover Bushing Removal/ Installation Tool (all clutches)	5020629
#5	1	P-90 Driven Clutch Cover Bushing Removal Tool	5020631
#8	1	Main Puller Adapter	5020632
#9	1	Adapter Reducer	5010279
#10	1	Number Two Puller Adapter	5020633

NOTE: Bushings are installed at the factory using Loctite™ 609. In order to remove bushings it will be necessary to apply heat evenly to the area around each bushing. Clean all residual Loctite™ from bushing bore prior to installing new bushing.

CAUTION

Clutch components will be hot! In order to avoid serious burns, wear insulated gloves during the removal process.

Moveable Sheave - Bushing Removal

1. Remove clutch as outlined previously in this chapter.
2. Install handle end of the Piston Pin Puller (PN 2870386) securely into bench vise and lightly grease puller threads.

Piston Pin Puller (PN 2870386)

3. Remove nut from puller rod and set aside.

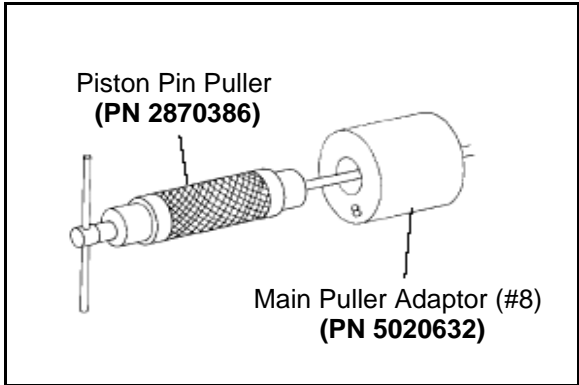

4. Install puller adapter (Item 10 from kit PN 2871226).
5. Install main adapter (Item D) onto puller.

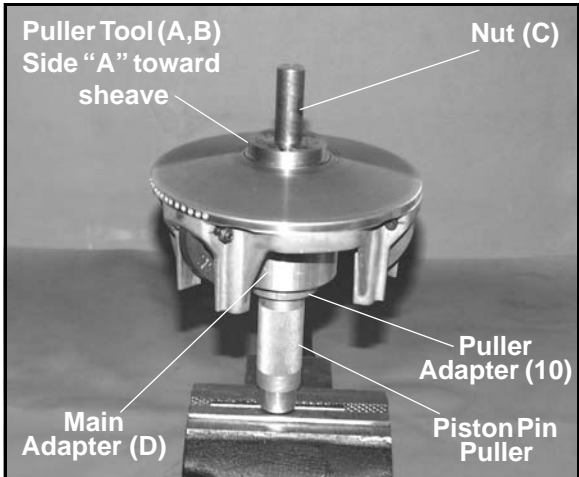

6. With towers pointing toward the vise, slide sheave onto puller rod.
7. Install removal tool (Item A, B) into center of sheave with "A side" toward sheave.

CLUTCHING (PVT)

NOTE: Use Bushing Tool PA-47336.

- Install nut (C) onto end of puller rod and hand tighten. Turn puller barrel to increase tension on sheave if needed. Using a hand held propane torch, apply heat around outside of bushing until tiny smoke tailings appear.
- Turn sheave counterclockwise on puller rod until it comes free. Lift sheave off puller.
- Remove nut from puller rod and set aside.
- Pull bushing removal tool and adapter from puller rod. Remove bushing from tool and discard.

Drive Clutch Bushing Installation

- Place main adapter (Item 8) on puller.

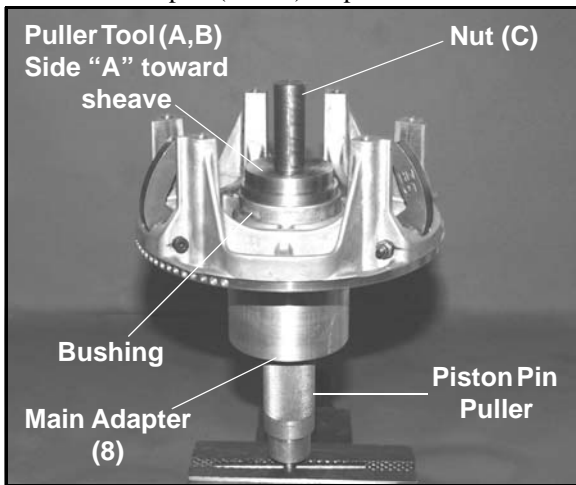

- Apply Loctite™ 609 evenly to bushing bore inside moveable sheave.
- Set bushing in place on sheave.
- Insert installation puller tool (Item A/B) with “A” side down, into center of bushing.
NOTE: Some models use Bushing Tool PA-47336.
- With towers pointing upward, slide sheave, bushing and tool onto puller rod.
- Install nut on puller rod and hand tighten. Turn barrel to apply additional tension if needed.
- Turn sheave counterclockwise, making sure bushing is drawn straight into bore. Continue until bushing is seated.
- Remove nut from puller rod and set aside.
- Remove sheave from puller.
- Remove installation tool.

Cover Bushing Removal

- Install main adapter (Item 8) on puller.

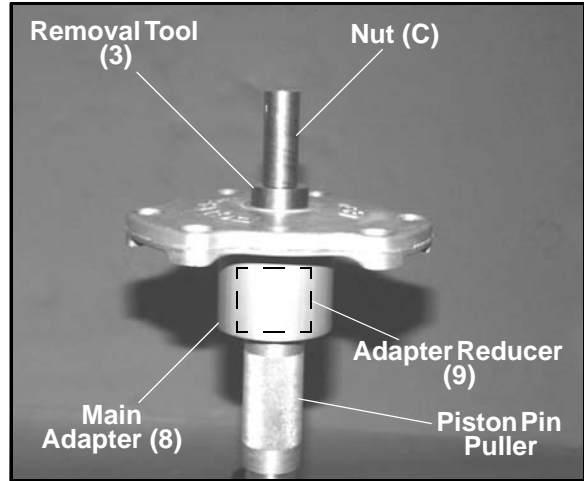

- Install adapter reducer (Item 9).
- From outside of clutch cover, insert removal tool (Item 3) into cover bushing.
- With inside of cover toward vise, slide cover onto puller.
- Install nut onto puller rod and hand tighten. Turn puller barrel to increase tension as needed.
- Turn clutch cover counterclockwise on puller rod until bushing is removed and cover comes free.
- Remove nut from puller rod and set aside.
- Remove bushing and bushing removal tool from puller. Discard bushing.

Cover Bushing Installation

- Apply Loctite™ 609 evenly to bushing bore in cover.
- Working from inside of cover, insert new bushing and bushing installation tool into center of clutch cover.
- With main adapter on puller, insert cover onto puller rod, placing outside of cover toward vise.
- Install nut on rod and hand tighten. Turn puller barrel to apply more tension if needed.
- Turn clutch cover counterclockwise on puller rod until bushing is seated.
- Remove nut from puller rod. Take installation tool and clutch cover off rod.

Clutch Assembly

NOTE: It is important that the same number and thickness of washers are reinstalled beneath the spider during assembly. The Teflon bushings are self-lubricating.

 CAUTION
Do not apply oil or grease to the bushings.

Reassemble the drive clutch in the sequence provided below. Be sure the “X”, or the marks that were made earlier are aligned during each phase of assembly.



1. Install moveable sheave onto fixed sheave.
2. Install spider spacers. Use same quantity and thickness as were removed.

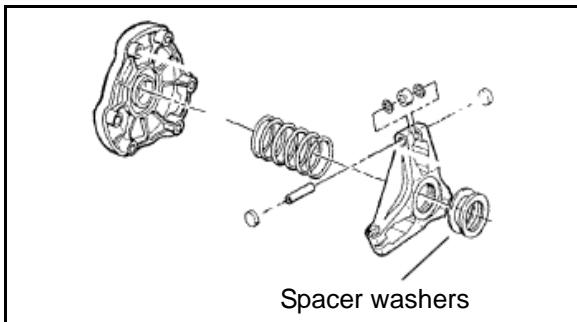

3. Compress spider buttons for each tower and install spider, making sure that “X”, or the marks that were made earlier, on spider aligns with “X”, or the marks that were made earlier, in moveable sheave.

4. Torque the spider (**counter-clockwise**) to specification using the holding fixture and spider tool. Torque with smooth motion to avoid damage to the stationary sheave.

IMPORTANT: The clutch shaft has **left-hand threads**. Be sure to turn the Spider Removal Tool in a **counter-clockwise direction** to reinstall.

 = T
Spider Torque: 200 ft. lbs. (271 Nm)

 CAUTION
Be sure the spider spacer washers are fully seated in the recessed area in the spider. Any misalignment will alter clutch balance. Inverting the clutch while initially tightening the spider will help position the washers.

5. Install the limiter spacer over the shaft and on top of spider.
6. Install shift weights using new lock nuts on the bolts.

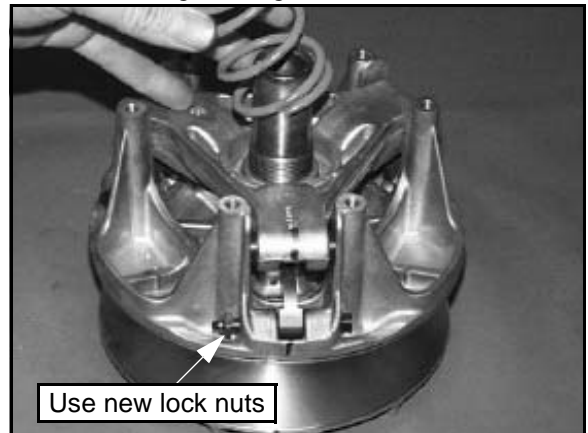

7. Reinstall clutch spring.
8. Reinstall cover, aligning “X” mark with other marks.
9. Torque cover bolts evenly to specification.

 = T
Cover Bolt Torque: 100 in. lbs. (11 Nm)

CLUTCHING (PVT)

DRIVEN CLUTCH SERVICE

Clutch Disassembly

1. Remove driven clutch from the transmission input shaft. Do not attempt disassembly of the driven clutch from the outside snap ring. The driven clutch must be disassembled from the helix side.

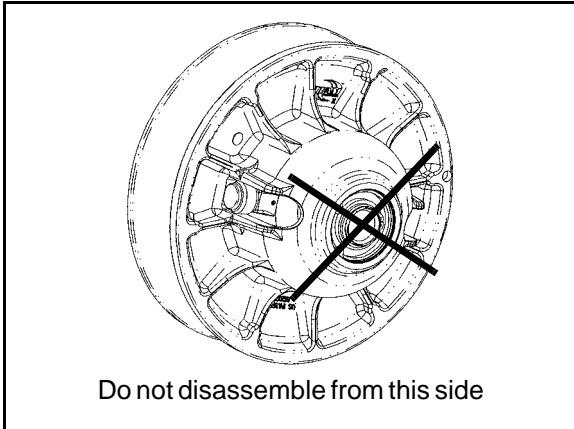

2. It is important to mark the position of the shaft, cam cover, and sheave before disassembly or use the X's on the components for reference. This will aid in reassembly and helps to maintain clutch balance after reassembly.

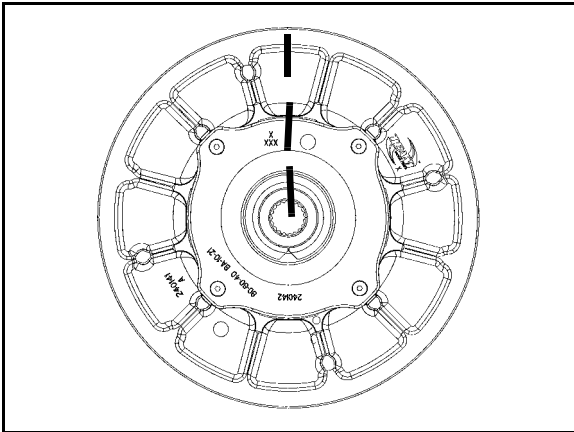

3. Remove the four screws that secure the cam (helix) assembly using a T25 Torx driver.

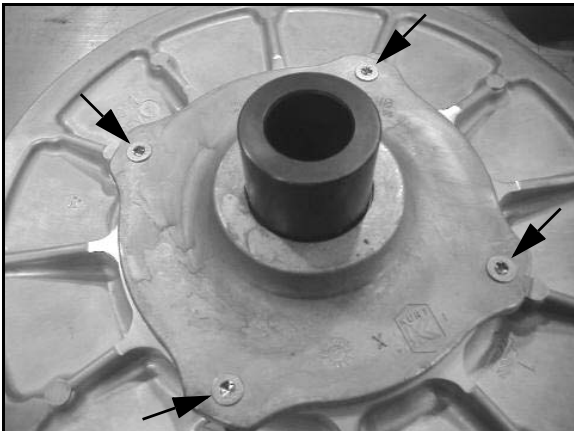

4. Place the clutch into the Clutch Compression Tool PN 8700220. Using Compression Extensions PN PS-45909, press down on top of the spider assembly, compressing the spider onto the shaft. Remove snap ring (A) and slowly release the assembly.

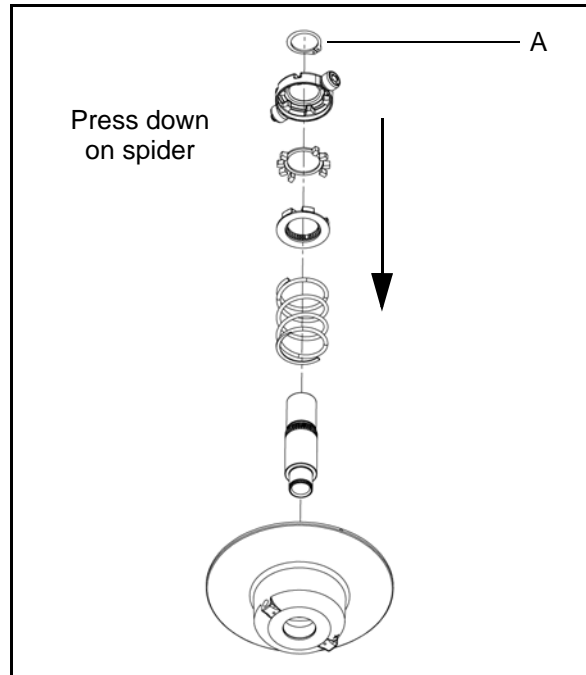

5. Remove the spider assembly and spring (B).

NOTE: Spring is compression only and has no torsional wind.

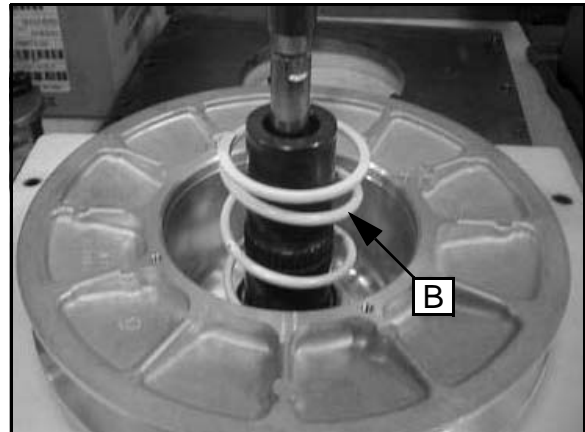

- Remove the inside spider plate (D) and spider dampener (E). Inspect the spider dampener (E) for wear and replace if needed.

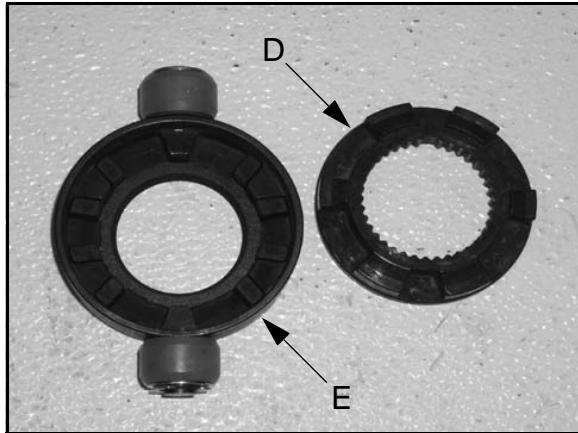

- Remove the E-clips (F), washers (G), and the clutch rollers (H). Inspect the rollers for wear; replace if worn.

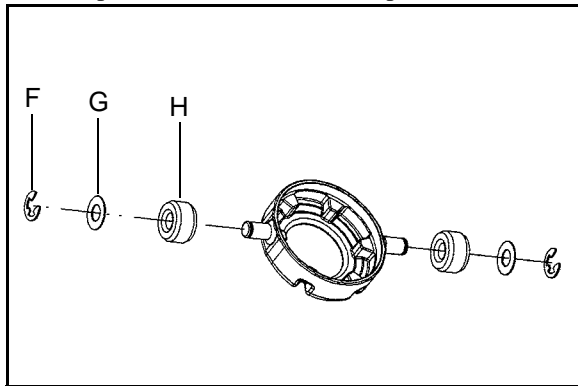

- Remove the clutch assembly from the holding tool. Remove the large outer retaining ring (I) and the inner retaining ring (J).

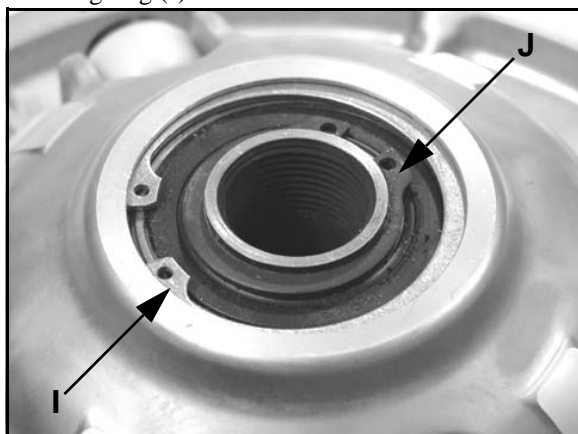

- Press out the spring pins (K) in the inner sheave.

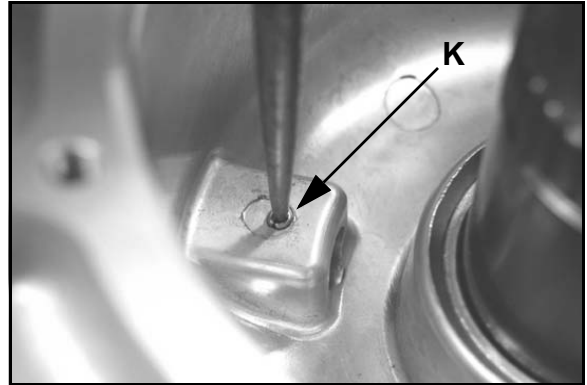

- Pull out the clutch roller pins (L) and rollers (M).

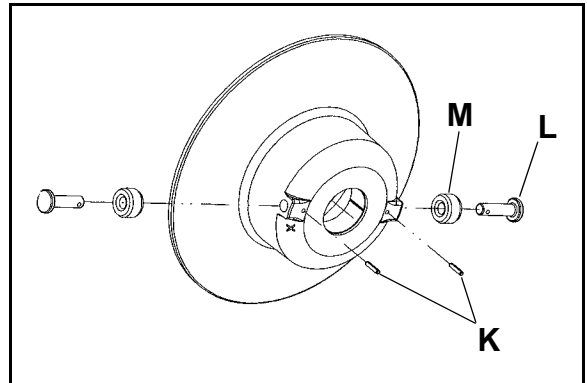

- Press the shaft and bearing out of the outer sheave using a press.

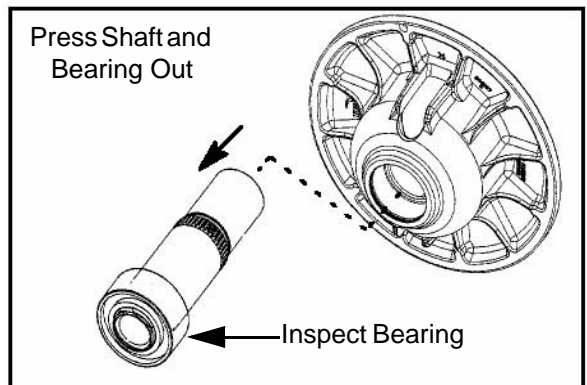
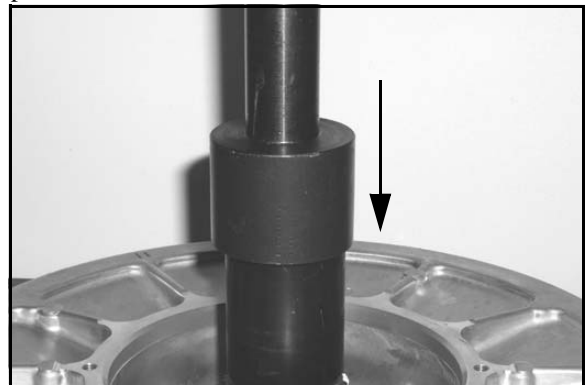

CLUTCHING (PVT)

12. Inspect the bearing for wear. Spin the bearing, if the bearing does not spin smoothly, replace it. To remove the bearing, press the bearing off the shaft.

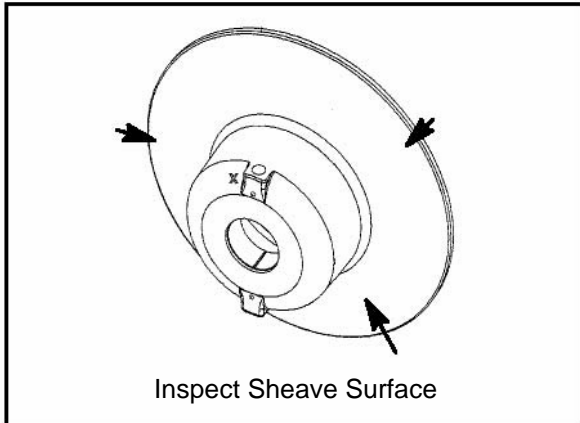

13. Inspect the cam (helix) assembly bushing for wear. If the bushing is worn or the shaft does not fit snug into the bushing, replace the cam (helix) assembly.

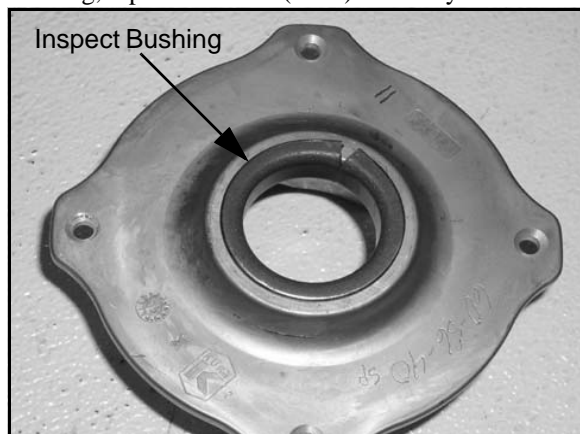

Bushing Service

IMPORTANT: Special Tools Required

EBS Clutch Bushing Tool Kit - 2201379

Item	Qty.	Part Description	Part #
A, B	1	EBS Puller Tool	5132027
C	1	EBS Puller Nut	5132501
D	1	EBS Main Adapter	5132029
E	1	EBS Bushing Removal Tool	5132028
--	1	Instructions	9915111

Additional Special Tools

Qty.	Part Description	Part #
1	Clutch Bushing Replacement Tool Kit	2871226
1	Piston Pin Puller	2870386

*Clutch Bushing Replacement Tool Kit (PN 2871226)

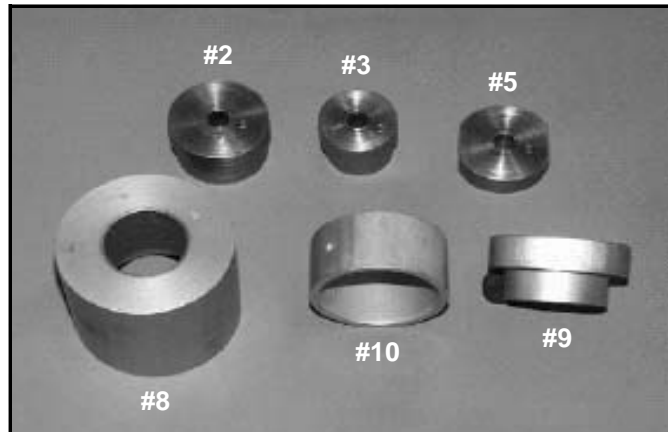

Item	Qty.	Part Description	Part #
#2	1	P-90 Drive/Driven Clutch Bushing Install Tool	5020628
#3	1	Drive Clutch Cover Bushing Removal/ Installation Tool (all clutches)	5020629
#5	1	P-90 Driven Clutch Cover Bushing Removal Tool	5020631
#8	1	Main Puller Adapter	5020632
#9	1	Adapter Reducer	5010279
#10	1	Number Two Puller Adapter	5020633

NOTE: Bushings are installed at the factory using Loctite™ 609. In order to remove bushings it will be necessary to apply heat evenly to the area around each bushing. Clean all residual Loctite™ from bushing bore prior to installing new bushing.

Clutch Bushing Removal

1. Install main puller adapter (Item 8) onto puller.
2. Install adapter reducer (Item 9).
3. Using a hand held propane torch, apply heat around outside of bushing until tiny smoke tailings appear.
4. Flip sheave over so bushing faces downward and install onto puller.
5. Install bushing tool (Item 2).

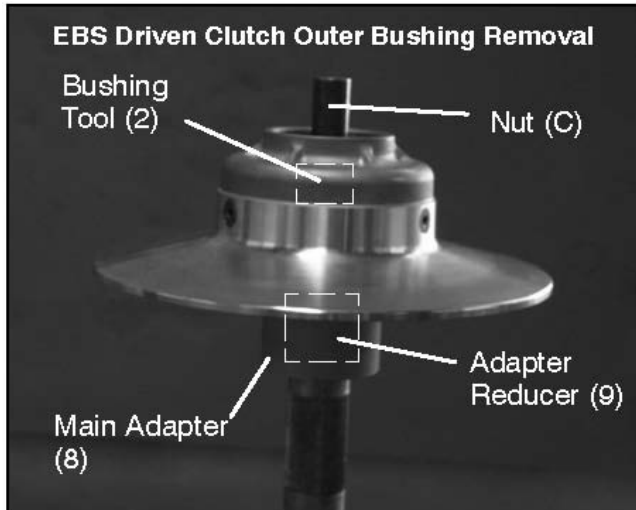

6. Install left hand nut (C) and spacer onto puller rod and tighten by hand. Turn puller barrel for further tension if needed.
7. Turn clutch sheave counterclockwise until bushing is removed and sheave comes free.
8. Remove nut (C) (left hand thread) from puller rod and set aside.
9. Remove adapters from puller.
10. Remove bushing and removal tool from adapters. Discard bushing.

Clutch Bushing Installation

1. Install puller adapter (Item 10) onto puller.
2. Install adapter (Item 9) onto puller.

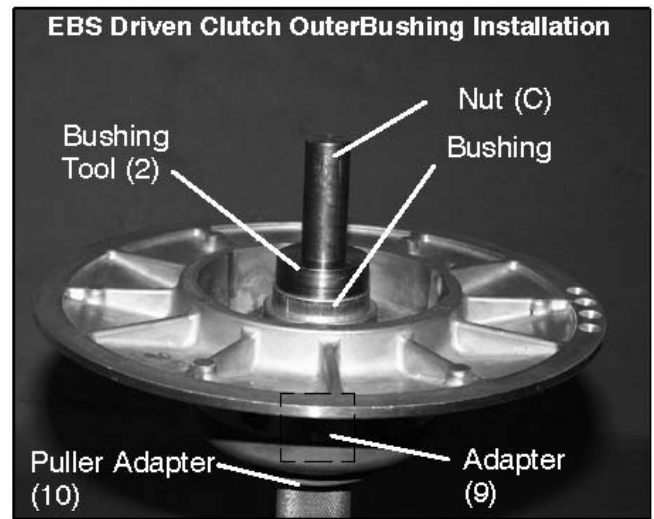

3. Apply Loctite™ 609 evenly to bushing bore inside moveable sheave.
4. Install sheave face down on puller.
5. Install new bushing on installation tool (Item 2) and install assembly into sheave.
6. Install left hand thread nut (C) onto puller rod and hand tighten against installation tool.
7. Turn clutch sheave counterclockwise, making sure bushing is drawn straight into bore. Continue until bushing is seated.
8. Remove nut (C) from puller rod and set aside.
9. Remove installation tool and clutch sheave from puller.

CLUTCHING (PVT)

Clutch Assembly

1. Install a new bearing onto the output shaft using a press.

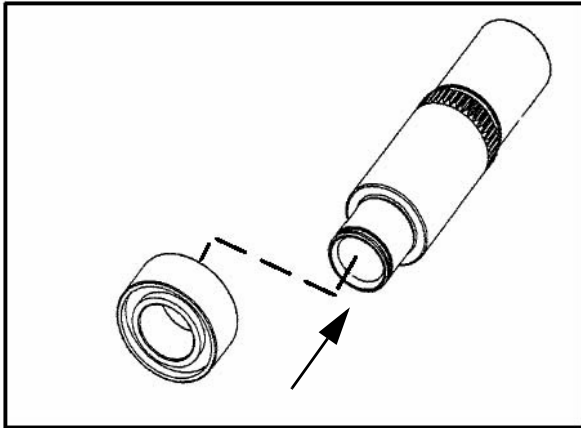

2. Install the shaft/bearing into the outer sheave.

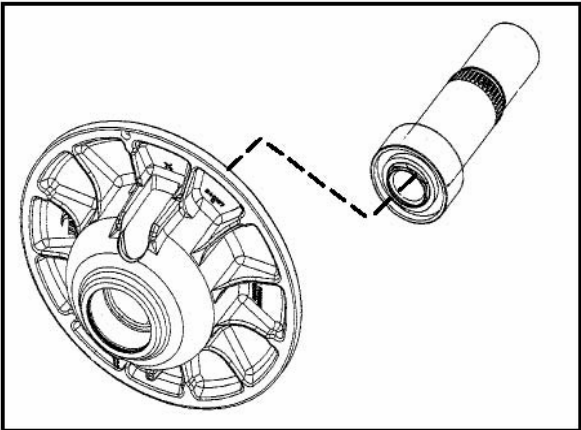

3. Install the small and large retaining rings into the outer sheave above the bearing.

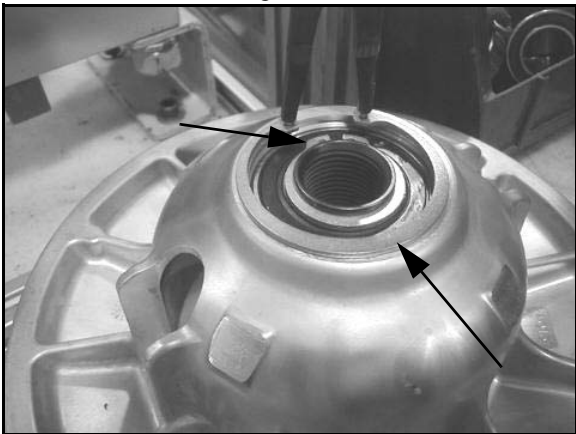

4. Line up the "X" on the moveable sheave with the "X" on the stationary sheave or use the marks previously used. Put the sheaves together.

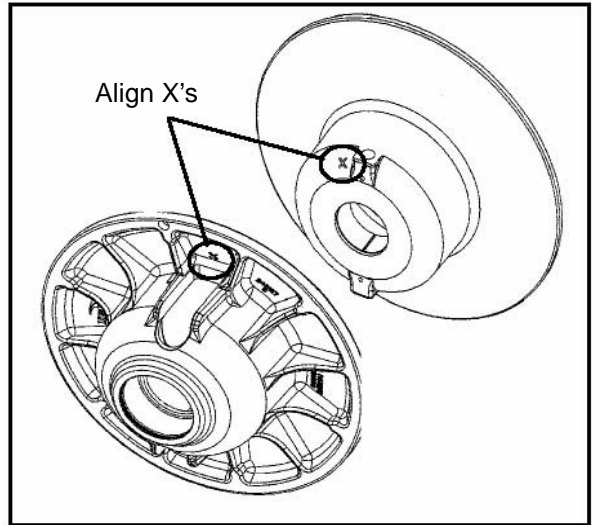

5. Install the roller (A) onto the roller pin (B) on both sides.

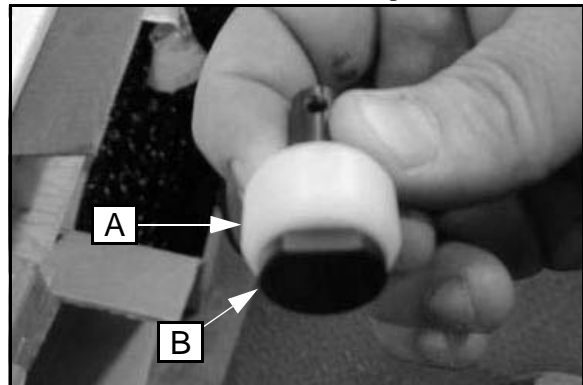

6. Install the roller pin into the sheave assembly on both sides. The flat side of the roller pin faces downward when the shaft side is laying flat on the bench.

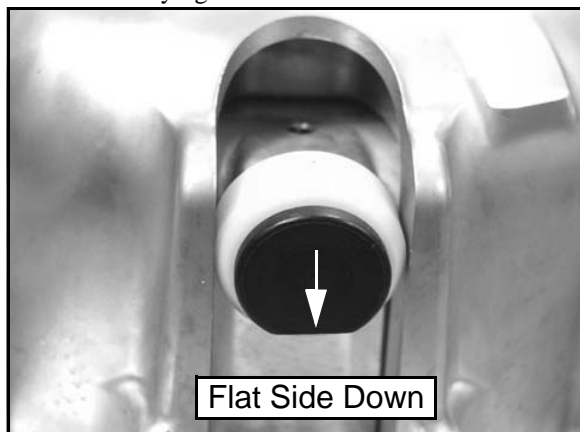

7. Install the spring pins (C) to secure the roller pins. Install until flush with sheave surface.

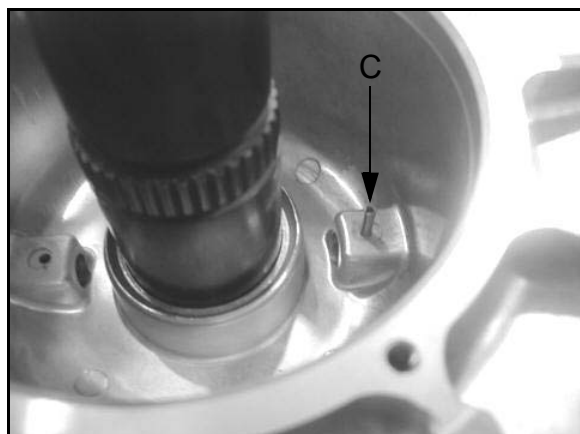

8. Install the spring over the shaft.

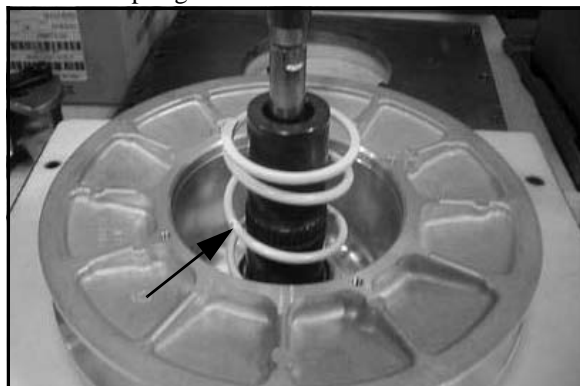

9. Install the clutch rollers (D) onto each side of the outside spider. Install the washers (E) and E-clips (F) to secure the rollers. The rollers should spin freely.

10. Install the spider dampener (G) inside the outer spider and install the inside spider plate (H).

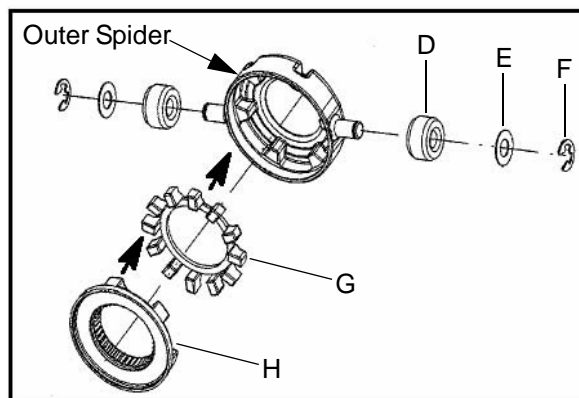

11. Install the spider assembly onto the shaft with the retaining ring on top of the spider. **NOTE:** Use the marks previously made to align the skip tooth spider, or use the "X" on top of the spider and align it with the skip tooth on the shaft.

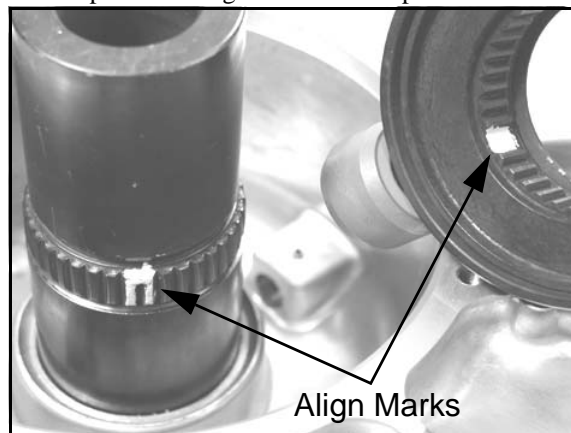

CLUTCHING (PVT)

12. Place the clutch into Clutch Compression Tool PN 8700220. Using Compression Extensions PN PS-45909, press down on the top of the spider assembly, pushing the spider onto the shaft.

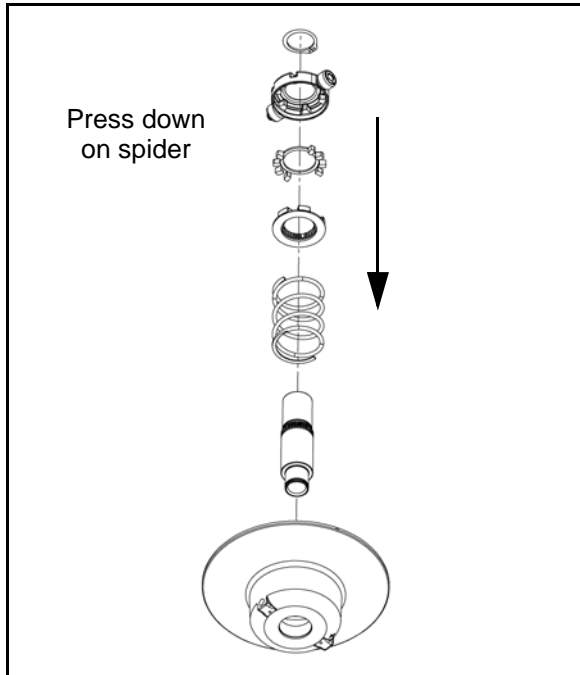

13. Slowly compress the spider into place. If the spider appears to bind while compressing, stop and make sure the skip tooth on the shaft and the spider are aligned. Once the spider passes the retaining ring notch on the shaft, install the retaining ring.

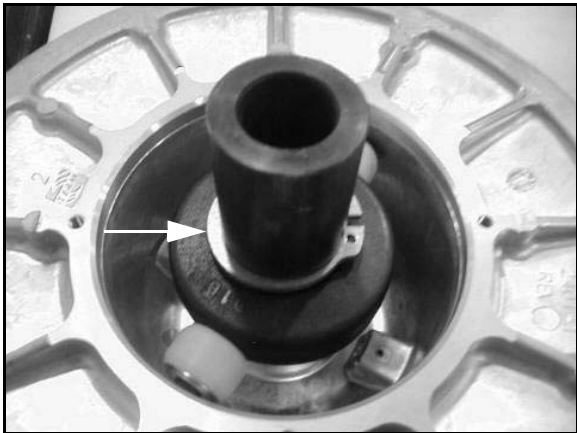

14. Install the cam (helix) assembly over the shaft. Line up the "X" on the cam, "X" on spider, and "X" on the stationary sheave or use the marks previously made before disassembly. **NOTE:** If the cam assembly (helix) is difficult to install, be sure the sheaves are aligned. To align the sheaves place the clutch assembly on a flat surface with the cam assembly (helix) side down. Press down on the moveable sheave belt face with both hands and the helix will release.



15. Use a T25 Torx driver to install the four screws and torque to specification.

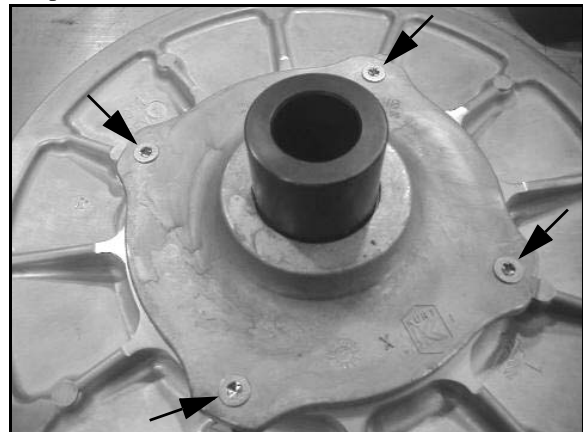

T25 Torx:
42-52 in. lbs. (4.75 - 5.88 Nm)

Exploded View

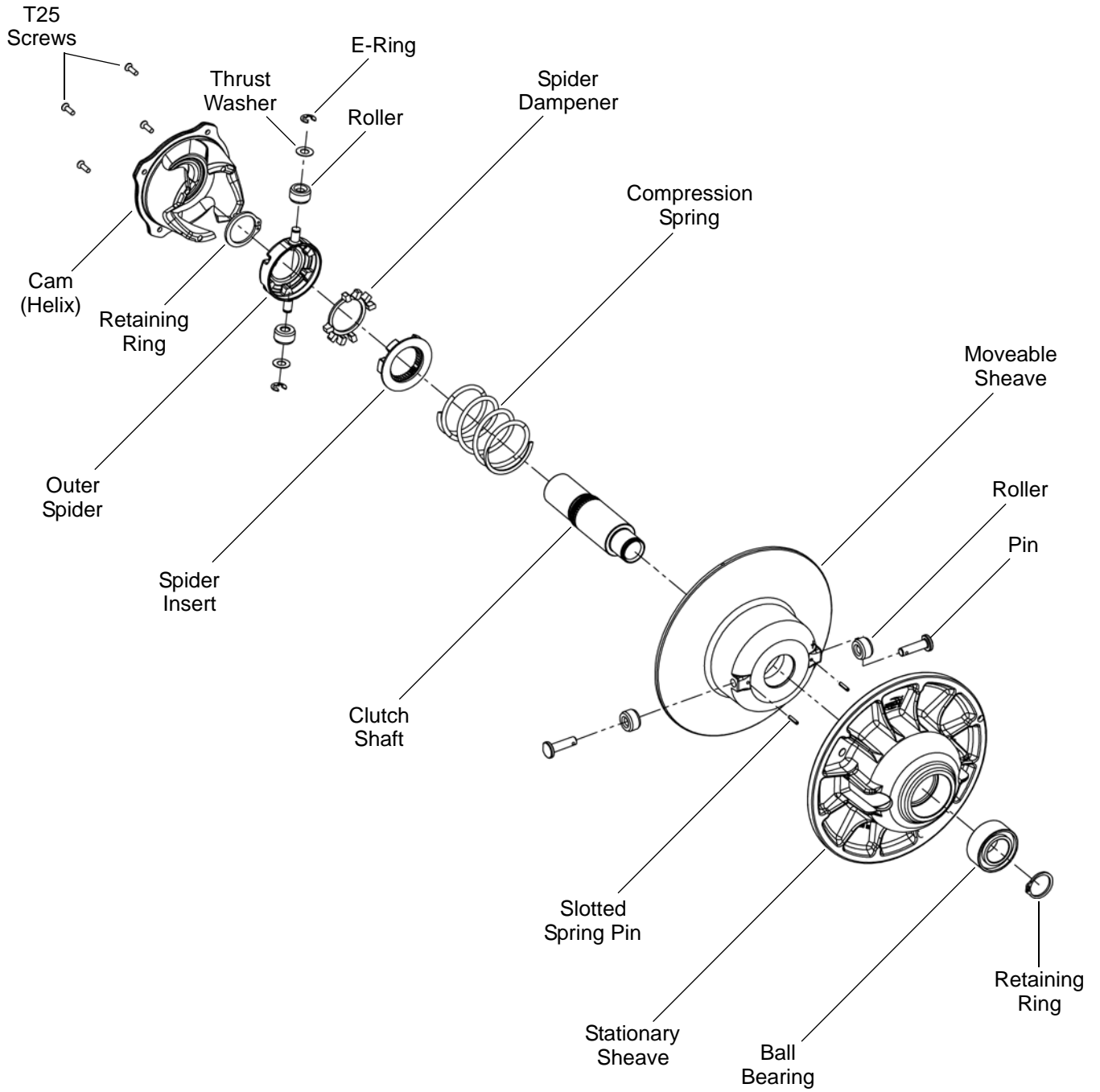

CLUTCHING (PVT)**TROUBLESHOOTING**

Situation	Probable Cause	Remedy
Engine RPM below specified operating range, although engine is properly tuned.	<ul style="list-style-type: none"> -Wrong or broken drive clutch spring. -Drive clutch shift weight too heavy. -Driven clutch spring broken or installed in wrong helix location. 	<ul style="list-style-type: none"> -Replace with recommended spring. -Install correct shift weight kit to match engine application. -Replace spring; refer to proper installation location.
Erratic engine operating RPM during acceleration or load variations.	<ul style="list-style-type: none"> -Drive clutch binding. -Belt worn unevenly - thin / burnt spots. -Driven clutch malfunction. -Sheave face grooved. 	<ul style="list-style-type: none"> A. Disassemble drive clutch; inspect shift weights for wear and free operation. B. Clean and polish stationary shaft hub; reassemble clutch without spring to determine problem area. Replace belt. Inspect movable sheave for excessive bushing clearance. -Replace the clutch.
Engine RPM above specified operating range.	<ul style="list-style-type: none"> -Incorrect drive clutch spring (too high spring rate). -Drive clutch shift weights incorrect for application (too light). -Drive clutch binding. -Driven clutch binding. -Clutch sheaves greasy; belt slippage. 	<ul style="list-style-type: none"> -Install correct recommended spring. -Install correct recommended shift weights. -Disassemble and clean clutch, inspecting shift weights and rollers. Reassemble without the spring and move sheaves through entire range to further determine probable cause. -Disassemble, clean, and inspect driven clutch. -Clean sheaves with denatured alcohol or brake cleaner, install new belt.
Harsh drive clutch engagement.	<ul style="list-style-type: none"> -Drive belt worn too narrow. -Excessive belt / sheave clearance with new belt. 	<ul style="list-style-type: none"> -Replace belt. -Perform belt / sheave clearance adjustment with shim washers beneath spider.
Drive belt turns over	<ul style="list-style-type: none"> -Wrong belt for application. 	<ul style="list-style-type: none"> -Replace with correct belt.
Belt burnt, thin spots	<ul style="list-style-type: none"> -Abuse (continued throttle application when vehicle is stationary, excess load) -Dragging brake -Slow, easy clutch engagement 	<ul style="list-style-type: none"> -Caution operator to operate machine within guidelines. -Vehicle operated with parking brake on. Inspect brake system. -Fast, effective use of throttle for efficient engagement.

Troubleshooting, Continued.....

Situation	Probable Cause	Remedy
PVT cover overheating (melting)	<ul style="list-style-type: none"> -Plugged air intake or outlet. -Belt slippage due to water, oil, grease, etc., rubbing on cover. -High vs. low range. 	<ul style="list-style-type: none"> -Clear obstruction -Inspect system. Clean , repair or replace as necessary. Seal PVT system ducts. -Instruct operator on guidelines for operation in proper driving range for different terrain as outlined in Owner's Safety and Maintenance Manual.
Water ingestion	<ul style="list-style-type: none"> -Cover seal or ducts leaking -Operator error 	<ul style="list-style-type: none"> -Find leak and repair as necessary. -Instruct operator on guidelines for operation in wet terrain as outlined in Owner's Safety and Maintenance Manual.
Belt slippage	<ul style="list-style-type: none"> -Belt worn out -Water ingestion -Belt contaminated with oil or grease 	<ul style="list-style-type: none"> -Replace belt. -Inspect and seal PVT system. -Inspect and clean.
PVT noise	<ul style="list-style-type: none"> -Belt worn or separated, thin spots, loose belt -Broken or worn clutch components, cover hitting clutches 	<ul style="list-style-type: none"> -Replace belt. -Inspect and repair as necessary.
Engagement erratic or stabby	<ul style="list-style-type: none"> -Thin spots on belt, worn belt -Drive clutch bushings stick 	<ul style="list-style-type: none"> -Replace belt. Refer to belt burnt troubleshooting and instruct operator. -Inspect and repair clutches.

CHAPTER 8

FINAL DRIVE

GENERAL SPECIFICATIONS	8.2
TORQUE SPECIFICATIONS / SPECIAL TOOLS	8.2
WHEELS	8.2
REMOVAL / INSTALLATION	8.2
WHEEL HUBS	8.3
FRONT BEARING CARRIER	8.4
INSPECTION / REMOVAL	8.4
BEARING REPLACEMENT	8.5
INSTALLATION	8.6
FRONT DRIVE SHAFT	8.7
REMOVAL	8.7
INSTALLATION	8.8
FRONT PROPSHAFT	8.9
REMOVAL / INSTALLATION	8.9
PROPSHAFT U-JOINT SERVICE	8.9
DISASSEMBLY	8.9
ASSEMBLY	8.10
FRONT GEARCASE - CENTRALIZED HILLIARD	8.11
EXPLODED VIEW	8.11
AWD OPERATION	8.12
ADC OPERATION	8.13
AWD DIAGNOSIS	8.14
GEARCASE REMOVAL	8.15
GEARCASE DISASSEMBLY / INSPECTION	8.16
GEARCASE ASSEMBLY	8.20
SETTING RING GEAR BACKLASH	8.22
GEARCASE INSTALLATION	8.23
ADC SYSTEM FLUID BLEEDING	8.25
REAR BEARING CARRIER	8.26
INSPECTION / REMOVAL	8.26
BEARING REPLACEMENT	8.27
BUSHING REPLACEMENT	8.28
INSTALLATION	8.28
REAR DRIVE SHAFT	8.30
REMOVAL	8.30
INSTALLATION	8.31
DRIVE SHAFT SERVICE	8.32
DRIVE SHAFT / CV JOINT HANDLING TIPS	8.32
OUTER CV JOINT / BOOT REPLACEMENT	8.32
INNER PLUNGING JOINT / BOOT REPLACEMENT	8.34
DRIVE SHAFT EXPLODED VIEW	8.36
REAR PROPSHAFT	8.37
REMOVAL / INSTALLATION	8.37
REAR GEARCASE	8.38
GEARCASE REMOVAL	8.38
GEARCASE DISASSEMBLY AND INSPECTION	8.40
GEARCASE BEARING AND SEAL REPLACEMENT	8.41
GEARCASE ASSEMBLY	8.42
GEARCASE INSTALLATION	8.43
GEARCASE EXPLODED VIEW	8.44

FINAL DRIVE

GENERAL SPECIFICATIONS

Torque Specifications

Item	Nut Type	Specification
Aluminum Wheels	Tapered Nut (Long)	75 ft. lbs. (102 Nm)
Steel Wheels	Tapered Nut (Short)	45 ft. lbs. (61 Nm)

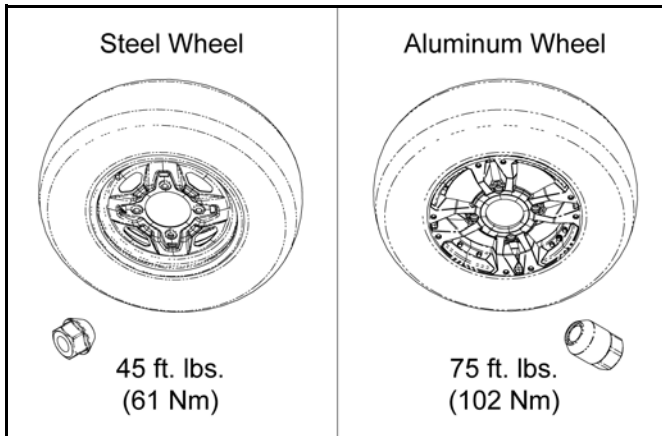

Item	Specification
Wheel Hub Retaining Nuts (front and rear)	80 ft. lbs. (108 Nm)
Steering Post to Bulkhead	20 ft. lbs. (27 Nm)
Steering Post to Gearcase	22 ft. lbs. (30 Nm)
Tie Rod to Bearing Carrier Tie Rod to Steering Frog	44 ft. lbs. (60 Nm)
Brake Caliper Mount Bolts	37 ft. lbs. (50 Nm)
Shock Mounting Bolts	37 ft. lbs. (50 Nm)
Front Ball Joint Pinch Bolts (upper and lower)	21 ft. lbs. (28 Nm)
Front A-arm to Frame Bolts (upper and lower)	40 ft. lbs. (54 Nm)
Front Gearcase Mount Bolts	36 ft. lbs. (49 Nm)
Rear A-arm to Frame Bolts (upper and lower)	45 ft. lbs. (61 Nm)
Rear Upper A-Arm to Bearing Carrier Bolts	40 ft. lbs. (54 Nm)
Rear Lower A-Arm to Bearing Carrier Bolts	45 ft. lbs. (61 Nm)
Rear Propshaft Bolts	18 ft. lbs. (24 Nm)
Rear Gearcase Mount Bolts	40 ft. lbs. (54 Nm)

CAUTION

Locking nuts, and bolts with pre-applied locking agent should be replaced if removed. The self-locking properties of the nut or bolt are reduced or destroyed during removal.

Special Tools

Part Number	Tool Description
2872608	Roller Pin Removal Tool
PU-48951	Axle Boot Clamp Tool

WHEELS

Removal

1. Position the vehicle on a level surface.
2. Stop the engine, place the transmission in PARK and lock the parking brake.
3. Loosen the wheel nuts slightly.
4. Elevate the appropriate side of the vehicle by placing a suitable stand under the footrest frame.
5. Remove the wheel nuts and remove the wheel.

Installation

1. Verify the transmission is still in PARK and the parking brake is locked.
2. Place the wheel in the correct position on the wheel hub. Be sure the valve stem is toward the outside and rotation arrows on the tire point toward forward rotation.
3. Install the wheel nuts and finger tighten them to align the center of the wheel holes with the center of the tapered nuts.

IMPORTANT: It is possible to torque the wheel nut on a steel rim without the nut being centered in the hole. Be sure to center the wheel nuts before applying torque to prevent wheel nuts from coming loose.

4. Carefully lower the vehicle to the ground.
5. Torque the wheel nuts to the proper torque specification.

CAUTION

Improperly installed wheels could affect vehicle handling and tire wear. On vehicles with tapered rear wheel nuts, make sure tapered end of nut goes into taper on wheel. Be sure to properly torque and install all wheel nuts.

WHEEL HUBS

Front Hub Exploded View

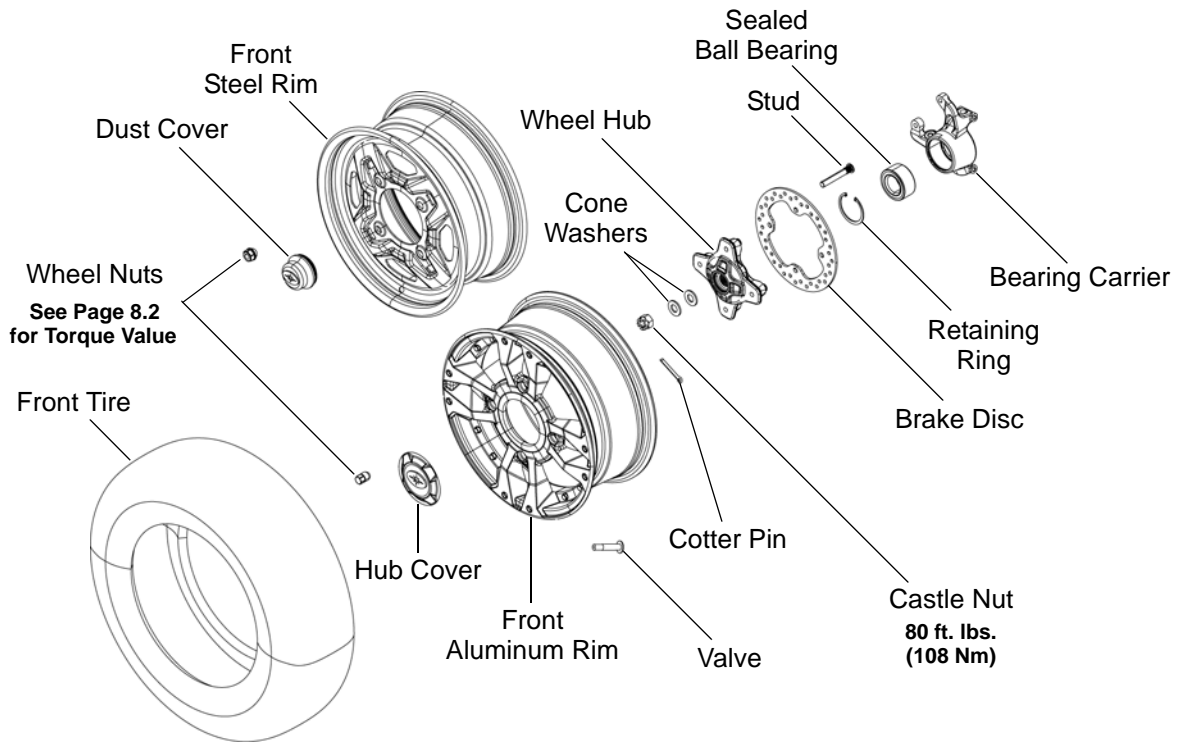

Rear Hub Exploded View

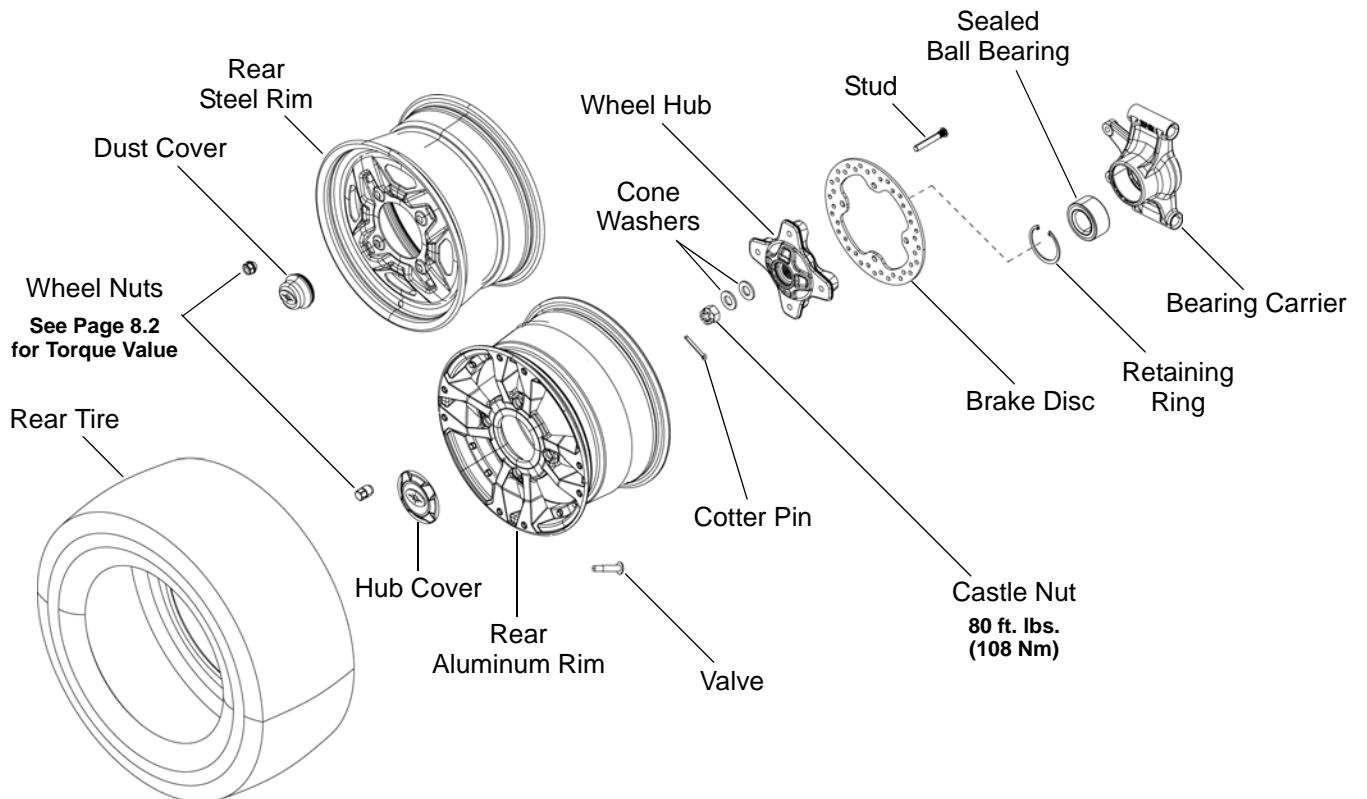

FINAL DRIVE

FRONT BEARING CARRIER

Inspection / Removal

1. Elevate front of vehicle and safely support machine under the frame area.

CAUTION

Serious injury may result if machine tips or falls. Be sure machine is secure before beginning this service procedure. Always wear eye protection.

2. Check bearings for side play by grasping the top and bottom of the tire firmly and checking for movement. The tire should rotate smoothly without binding or rough spots.
3. Remove the (4) wheel nuts and remove the front wheel (see "Wheel Removal").
4. Remove the cotter pin and loosen the front wheel hub castle nut. Remove the nut and (2) cone washers from the front wheel hub assembly.

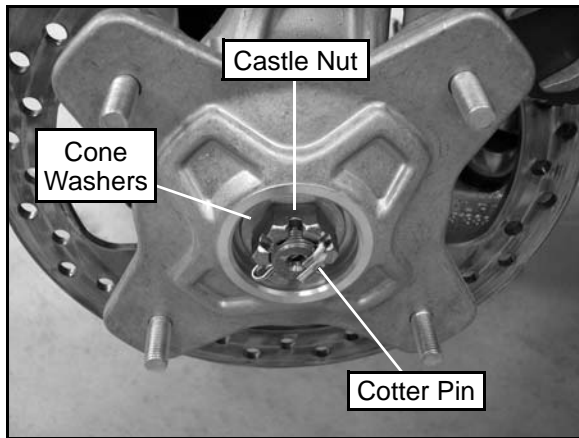

5. Remove the (2) brake caliper mounting bolts and caliper. **CAUTION:** Do not hang the caliper by the brake line. Use wire to hang caliper to prevent damage to the brake line.

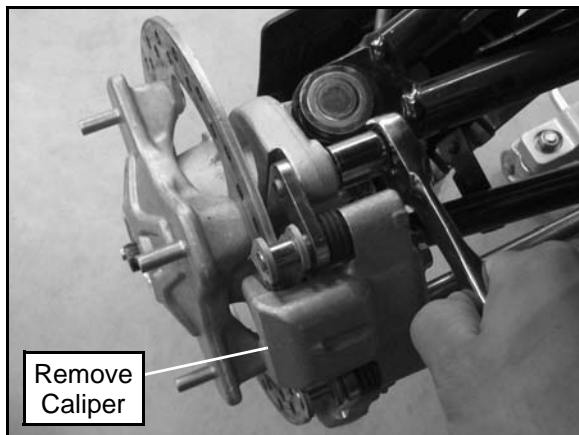

6. Remove the front wheel hub assembly.
7. Remove the cotter pin from the bottom of the tie rod end.
8. Hold the top of the rod end with a 13 mm open-end wrench and remove the nut from the bottom.

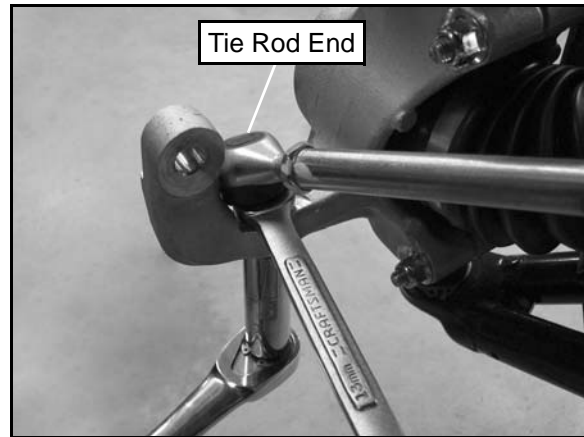

9. Remove the steering tie rod from the bearing carrier.
10. Remove the upper and lower ball joint pinch bolts.



11. Using a soft faced hammer, lightly tap on the bearing carrier while removing the upper and lower ball joint ends.
12. Remove the bearing carrier from the front drive shaft.

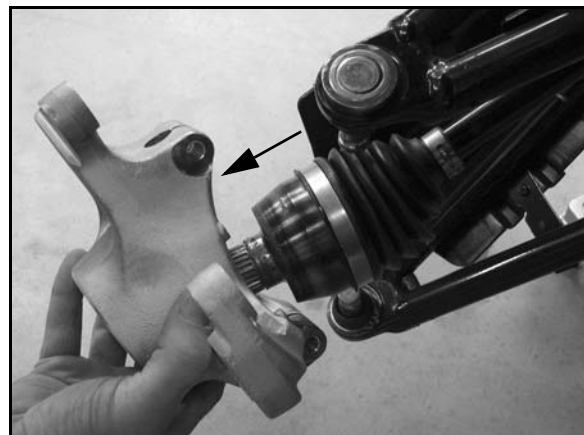

- Rotate bearing by hand and check for smooth rotation. Visually inspect bearing for moisture, dirt, or corrosion.

NOTE: Due to extremely close tolerances and minimal wear, the bearings must be inspected visually, and by feel. While rotating bearings by hand, inspect for rough spots, discoloration, or corrosion. The bearings should turn smoothly and quietly, with no detectable up and down movement and minimal movement sideways between inner and outer race.

- Replace bearing if moisture, dirt, corrosion, or roughness is evident.

Bearing Replacement

Bearing Removal

- Remove the outer retaining ring from the bearing carrier.

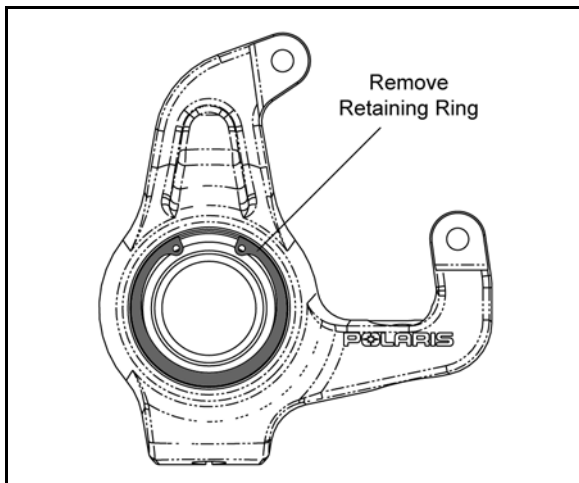

- Support the bearing carrier in an arbor press and remove the bearing by pressing it out from the back side.

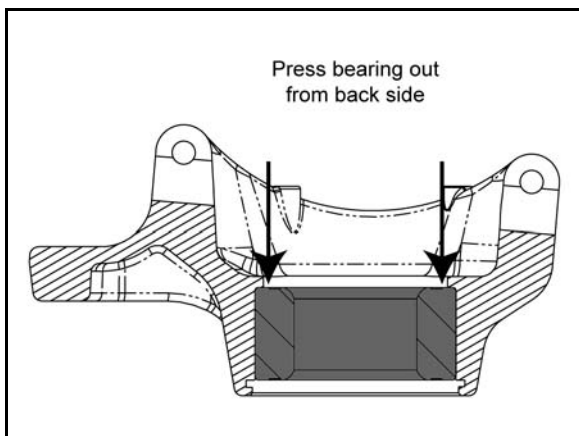

- Inspect the bearing carrier housing for scratches, wear or damage. Replace front bearing carrier if damaged.

Bearing Installation

- Thoroughly clean the front bearing carrier housing and the outer race on the new bearing. Be sure that all oil residue has been removed from each surface.
- Support the bottom of the bearing carrier housing.



CAUTION

Use an arbor and press only on the outer race or bearing damage may occur.

- Apply **Loctite® 603™** retaining compound to the outer circumference of the new bearing race and carefully press the new bearing into the bearing carrier housing.

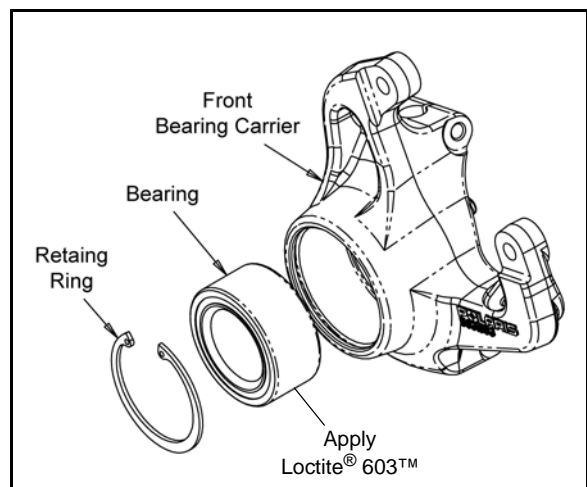

NOTE: Use care to not allow any of the Loctite® compound to get in the bearing.

- Wipe the housing clean of any excess compound and install the snap ring.

FINAL DRIVE

Installation

1. Install the drive shaft axle through the backside of the bearing carrier.
2. Install the upper and lower ball joint ends into the bearing carrier. Install the pinch bolts and torque to specification.

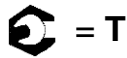
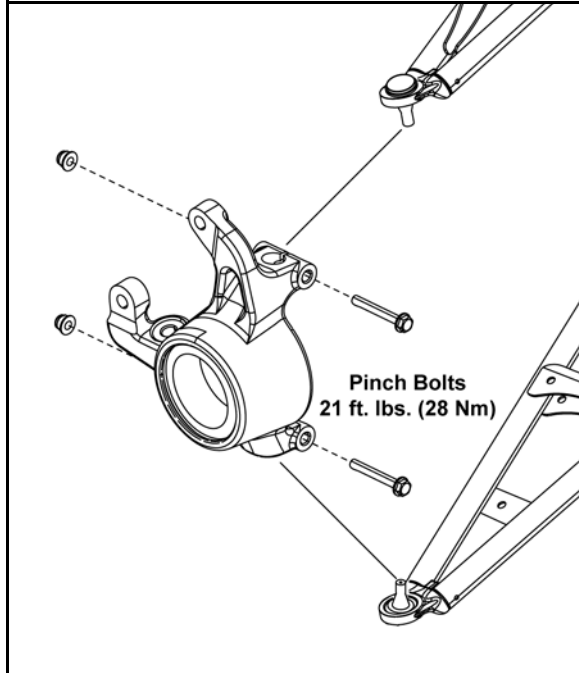

Pinch Bolts:
21 ft. lbs. (28 Nm)

3. Apply grease to drive shaft axle splines.
4. Install the front wheel hub assembly, cone washers, and hand tighten the castle nut. Install washers with domed side facing out toward the castle nut.

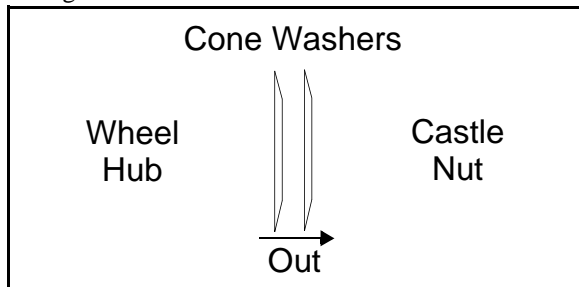

5. Install the brake caliper and torque the new mounting bolts to specification.



Front Caliper Mounting Bolts:
37 ft. lbs. (50 Nm)



New bolts have a pre-applied locking agent which is destroyed upon removal. Always use new brake caliper mounting bolts upon assembly.

6. Install the steering tie rod end onto the front bearing carrier. Torque fastener to specification and install a new cotter pin.

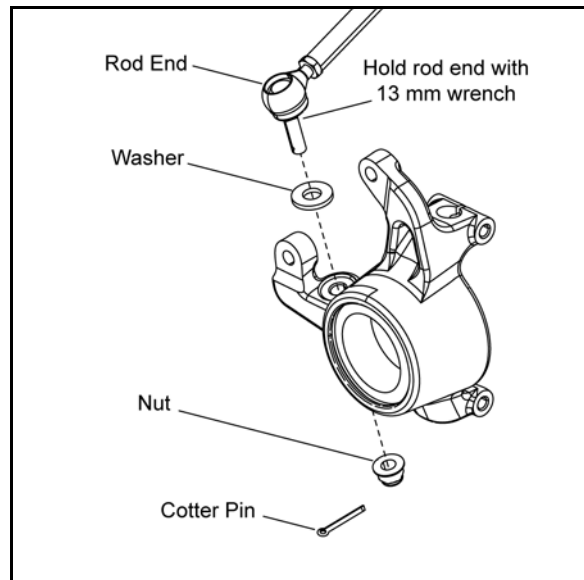

Tie Rod End Fastener:
44 ft. lbs. (60 Nm)

- Torque the wheel hub castle nut to specification and install a NEW cotter pin. Tighten nut slightly if necessary to align cotter pin holes.

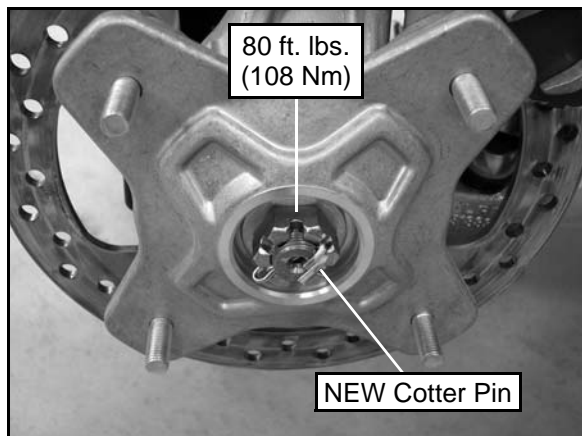

 = T

Wheel Hub Castle Nut:
80 ft. lbs. (108 Nm)

- Install the front wheel and (4) wheel nuts. Torque wheel nuts to specification.

 = T

Wheel Nuts:
Steel Wheels: 45 ft. lbs. (61 Nm)
Aluminum Wheels: 75 ft. lbs. (102 Nm)

- Rotate wheel and check for smooth operation. Bend both ends of cotter pin around end of spindle in different directions.

FRONT DRIVE SHAFT

Removal

- Elevate front of vehicle and safely support machine under the frame area.

 CAUTION

Serious injury may result if machine tips or falls. Be sure machine is secure before beginning this service procedure. Always wear eye protection.

- Remove the (4) wheel nuts and remove the front wheel (see "Wheel Removal").
- Remove the cotter pin and loosen the front wheel hub castle nut. Remove the nut and (2) cone washers from the front wheel hub assembly.

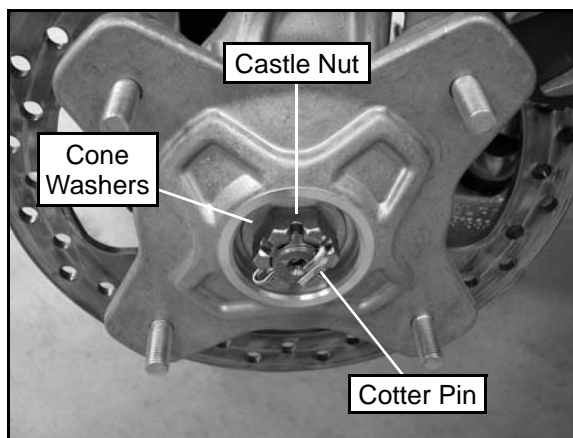

- Remove the (2) brake caliper mounting bolts and caliper. **CAUTION:** Do not hang the caliper by the brake line. Use wire to hang caliper to prevent damage to the brake line.

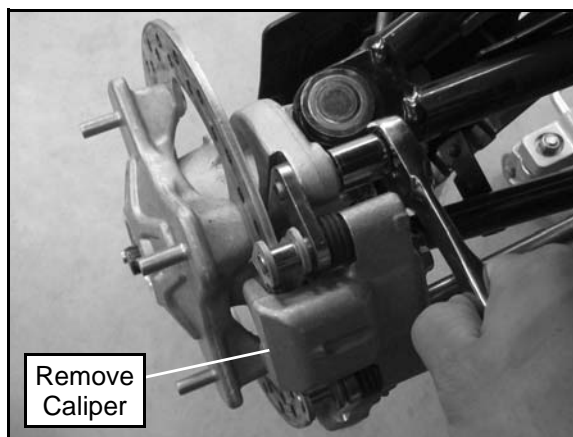

- Remove the front wheel hub assembly.

FINAL DRIVE

6. Remove the upper ball joint pinch bolt.
7. Using a soft faced hammer, lightly tap on the upper A-arm to remove it from the bearing carrier.
8. Remove the drive shaft from the front bearing carrier.

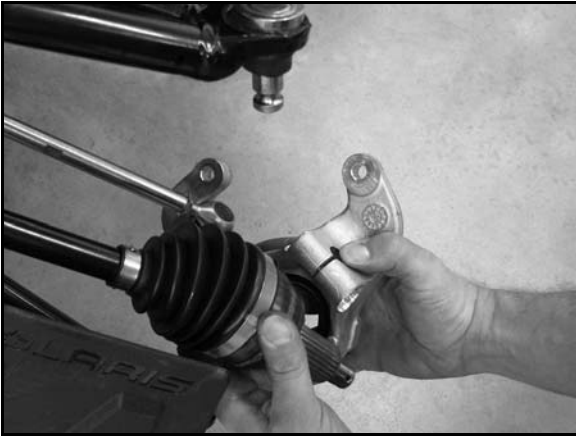

9. With a short, sharp jerk, remove drive shaft from the front gearcase.

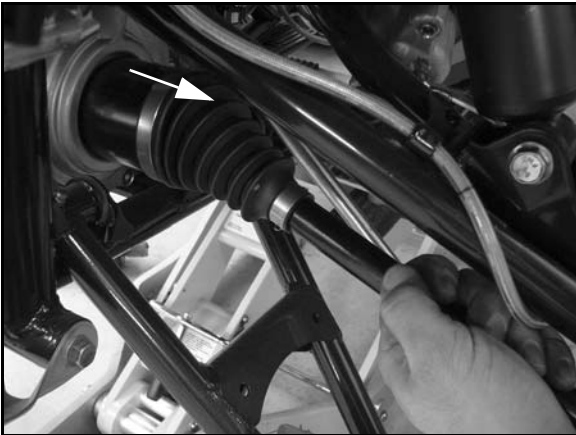

10. Refer to the "DRIVE SHAFT SERVICE" procedure if repairing the drive shaft.

Installation

1. Install a new spring ring on the end of the drive shaft and apply an anti-seize compound to the splines.

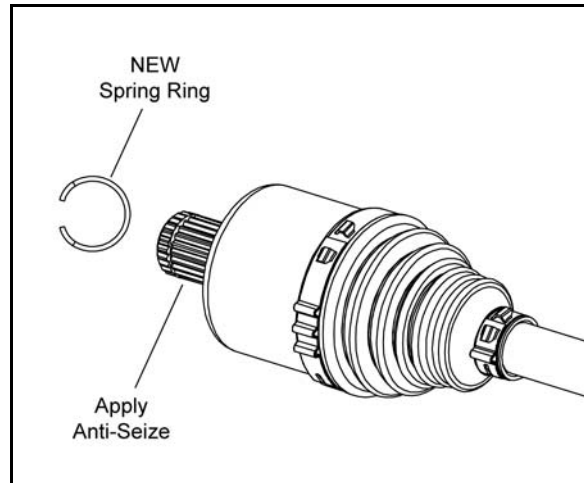

2. Align the splines of the drive shaft with the front gearcase and reinstall the drive shaft. Use a rubber mallet to tap on the outboard end of the drive shaft if necessary.
3. Install the drive shaft into the front bearing carrier.
4. Refer to the "FRONT BEARING CARRIER - Installation" procedure within this chapter to properly reassemble the vehicle.

FRONT PROPSHAFT

Removal

1. Locate the front propshaft roll pin through the right front wheel well. Position the vehicle for roll pin removal.
2. Use the Roll Pin Removal Tool (PN 2872608), to drive out the roll pin from the front propshaft.

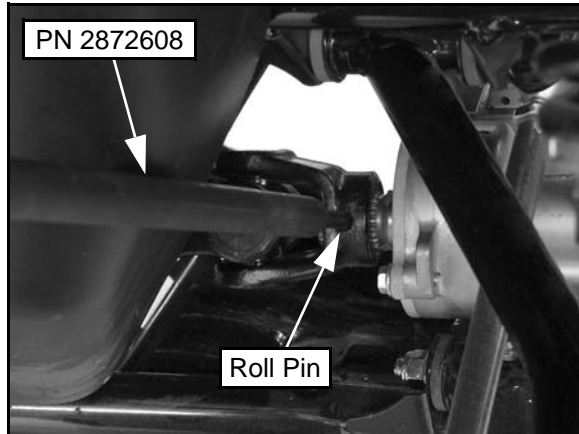

Roll Pin Removal Tool (PN 2872608)

3. Remove the seat, upper right side panel and right footwell.
4. Pull the shaft back towards the transmission to remove it from the front gearcase input shaft, then pull it forward to remove it from the transmission output shaft.

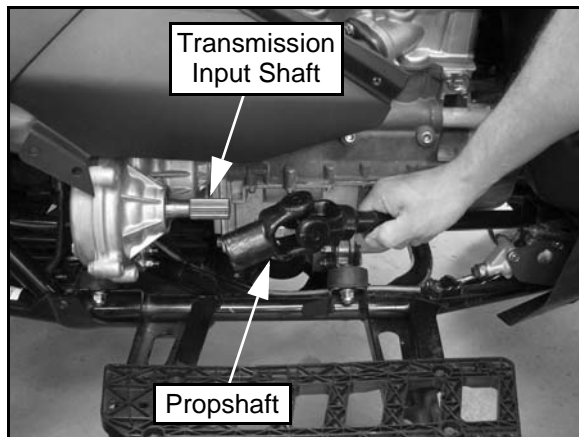

Installation

1. Apply anti-seize compound to all splines. Slide propshaft back onto the transmission output shaft, then slide it up onto the front gearcase input shaft, verify pin holes are aligned.
2. Using Roll Pin Tool (PN 2872608), install a NEW roll pin (spring pin) into the propshaft.
3. Reinstall the footwell, side panel and seat (see Chapter 9).

PROPSHAFT U-JOINT SERVICE

Disassembly

1. Remove internal or external snap ring from bearing caps.

CAUTION

Always wear eye protection.



NOTE: If yoke or bearing is removed, cross bearing must be replaced. Note orientation of grease fitting and mark inner and outer yoke for correct re-positioning during installation.

2. Support inner yoke as shown and drive outer yoke down (bearing cap out) with a soft face hammer.



FINAL DRIVE

- Support U-joint in vise as shown and drive inner yoke down to remove remaining bearing caps.



- Force U-joint cross to one side and lift out of inner yoke.

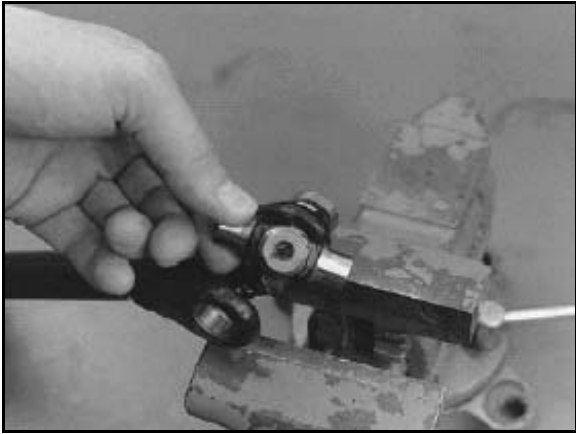

- Using a suitable arbor, fully seat the bearing cap in one side. Continually check for free movement of bearing cross as bearing caps are assembled.

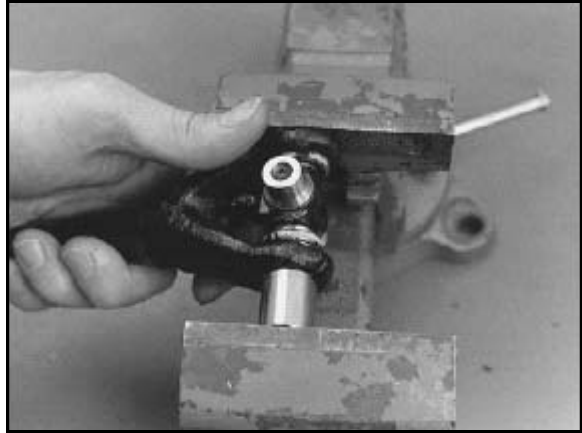

- Install snap ring to contain bearing cap just installed. Repeat procedure for other side.
- Install outer yoke, aligning marks made at disassembly and repeat Steps 1-3 to install bearing caps on outer yoke.
- Seat all bearing caps against snap rings by supporting cross shaft and tapping on each corner as shown.

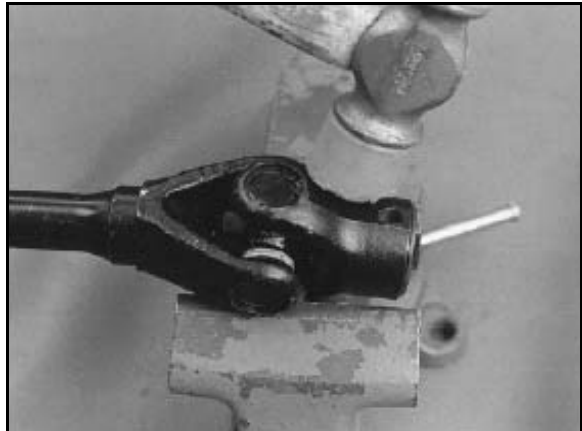

Assembly

- Install new bearing caps in yoke by hand. Carefully install U-joint cross with grease fitting properly positioned inward toward center of shaft. Take care not to dislodge needle bearings upon installation of cross joint.
- Tighten vise to force bearing caps in.

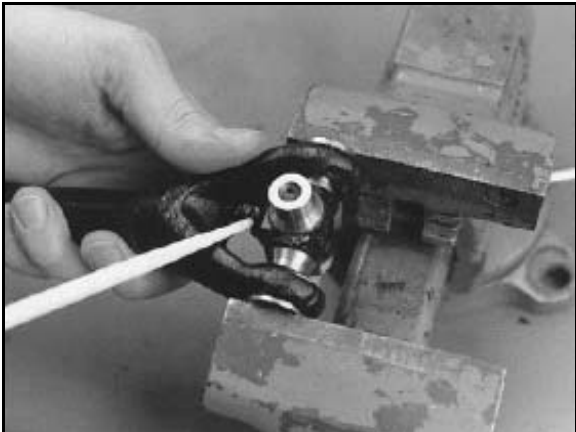

- When installation is complete, yokes must pivot freely in all directions without binding. If the joint is stiff or binding, tap the yoke lightly to center the joint until it pivots freely.

FRONT GEARCASE - CENTRALIZED HILLIARD

Exploded View

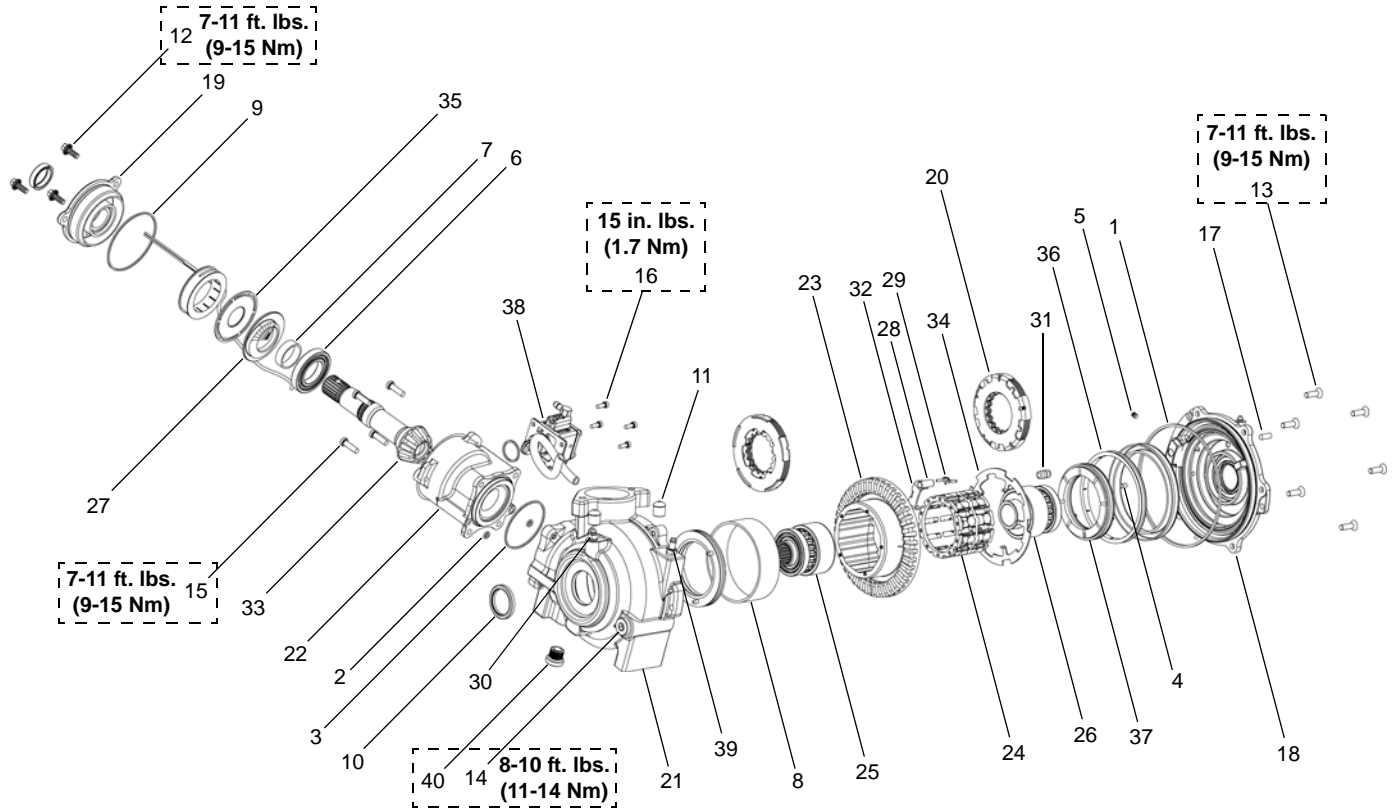

REF#	DESCRIPTION	QTY	REF#	DESCRIPTION	QTY
1	O-Ring	1	21	Gearcase Housing	1
2	O-Ring	3	22	Pinion Neck Housing	1
3	O-Ring	1	23	Clutch Housing	1
4	Dowel Pin	1	24	Roll Cage Assembly	1
5	Expander	1	25	Hub Assembly (female)	1
6	Bearing	3	26	Hub Assembly (male)	1
7	Bushing	1	27	Cam	1
8	Bushing	1	28	Roller	20
9	Bushing	1	29	H-Clip Spring	20
10	Oil Seal	2	30	Bleeder Screw	2
11	Cap Plug	2	31	Thrust Button Assembly	1
12	Bolt, M6	3	32	Thrust Plate	1
13	Screw, M6	6	33	Pinion Gear	1
14	Fill Plug	1	34	Armature Plate (AWD)	1
15	Cap Screw, M6	4	35	Armature Plate (ADC)	1
16	Screw, M4	4	36	AWD Coil	1
17	Set Screw, M6	1	37	Piston	2
18	Cover Housing	1	38	Pump Assembly	1
19	Pinion Cover	1	39	Vent	1
20	Clutch Pack Assembly	2	40	Drain Plug, Magnetic	1

FINAL DRIVE

AWD Operation

The AWD switch may be turned on or off while the vehicle is moving, however, AWD will not enable until the engine RPM drops below 3100. Once the AWD is enabled, it remains enabled until the switch is turned off.

Engage the AWD switch before getting into conditions where the front wheel drive may be needed. If the rear wheels are spinning, release the throttle before switching to AWD.

CAUTION

Switching to AWD while the rear wheels are spinning may cause severe drive shaft and gearcase damage. Always switch to AWD while the rear wheels have traction or are at rest.

With the AWD switch off, the vehicle drives through the rear wheels only (2 wheel drive). When the AWD is enabled, the front drive acts as an on-demand AWD system. This means, the front drive will engage once the rear wheels have lost traction, and will remain engaged until the torque requirement goes away (i.e. rear wheels regain traction).

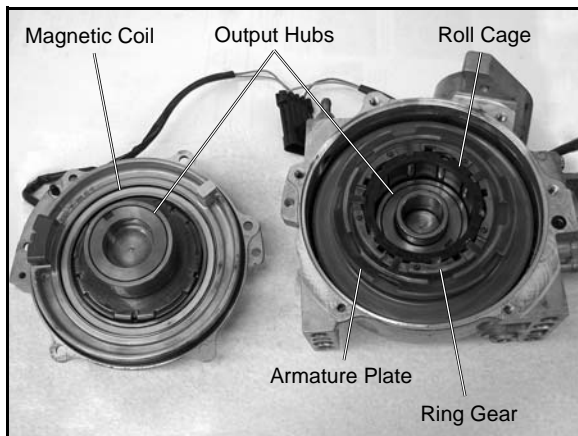

AWD Engagement: When the AWD switch is activated, the AWD coil is powered by a 12 Vdc input which creates a magnetic field. This magnetic field attracts an armature plate that is keyed to the roll cage. When the ring gear and roll cage are spinning (vehicle is moving), the energized coil and armature plate will apply drag to the roll cage that indexes the rollers inside the ring gear to an engagement position. While in the engagement position, the front drive will be in an “over-running” condition (not engaged), until the rear wheels lose traction. Once the rear wheels begin to lose traction, the front drive will engage by coupling the output hubs to the ring gear via the rollers. The front drive will remain engaged until the torque requirement goes away (i.e. rear wheels regain traction).

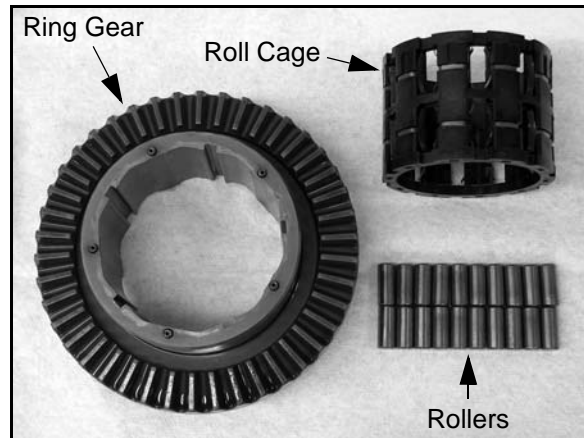

CAUTION

If the rear wheels are spinning, release the throttle before turning the AWD switch on. If AWD is engaged while the wheels are spinning, severe drive shaft and clutch damage could result.

AWD Disengagement: Once the rear wheels regain traction, the front wheels will return to the “over-running” condition. The vehicle is now back to rear wheel drive until the next loss of rear wheel traction occurs.

ADC Operation

Engaging the Front Gearcase: Active Descent Control (ADC) is controlled by the ECU and will not enable until the following conditions are met:

- Vehicle speed is below 15 mph (24 kph)
- Throttle Position Sensor (TPS) is at idle position
- The AWD switch is switched to the “ADC” position

Once the conditions are met for engagement, ADC remains engaged as long as the conditions are met.

With the AWD switch set to “2x4”, the vehicle drives only the rear wheels (2 wheel drive). When the AWD switch is set to “4x4”, the vehicle drives all four wheels (4 wheel drive). When the AWD switch is set to “4x4/ADC”, the vehicle drives all four wheels and, in addition to the rear wheel engine braking, the ADC coil provides front wheel engine braking at speeds less than 15 mph (24 kph) with the TPS at idle position.

ADC Engagement: When the AWD switch is set to “4x4/ADC”, a 12 Vdc current is present at the input shaft coil (1). Operation is controlled by the ECU grounding and ungrounding the coil. The coil’s magnetic field attracts a splined armature plate (2) on the pinion (input) shaft (4). The energized splined armature plate attracts the unsplined eccentric cam (3), which begins to turn with the input shaft. The eccentric cam drives a hydraulic piston/pump assembly (5). The pressure created by the pump assembly forces hydraulic fluid through passages to the piston assemblies (6) located in each case half. Hydraulic pressure forces the piston assemblies inward to compress the splined clutch packs (7) forming a dynamic coupling to each front drive axle, resulting in true all-wheel EBS operation upon deceleration.

Disengagement: Current to the ADC coil is turned off by the ECU anytime the following conditions are met:

- Throttle Position Sensor (TPS) moves off idle position
- The AWD switch is switched to “4x4” or “2x4”
- Vehicle speed is above 15 mph (24 kph)

Hydraulic pressure stops and the pistons release, disengaging the ADC function.

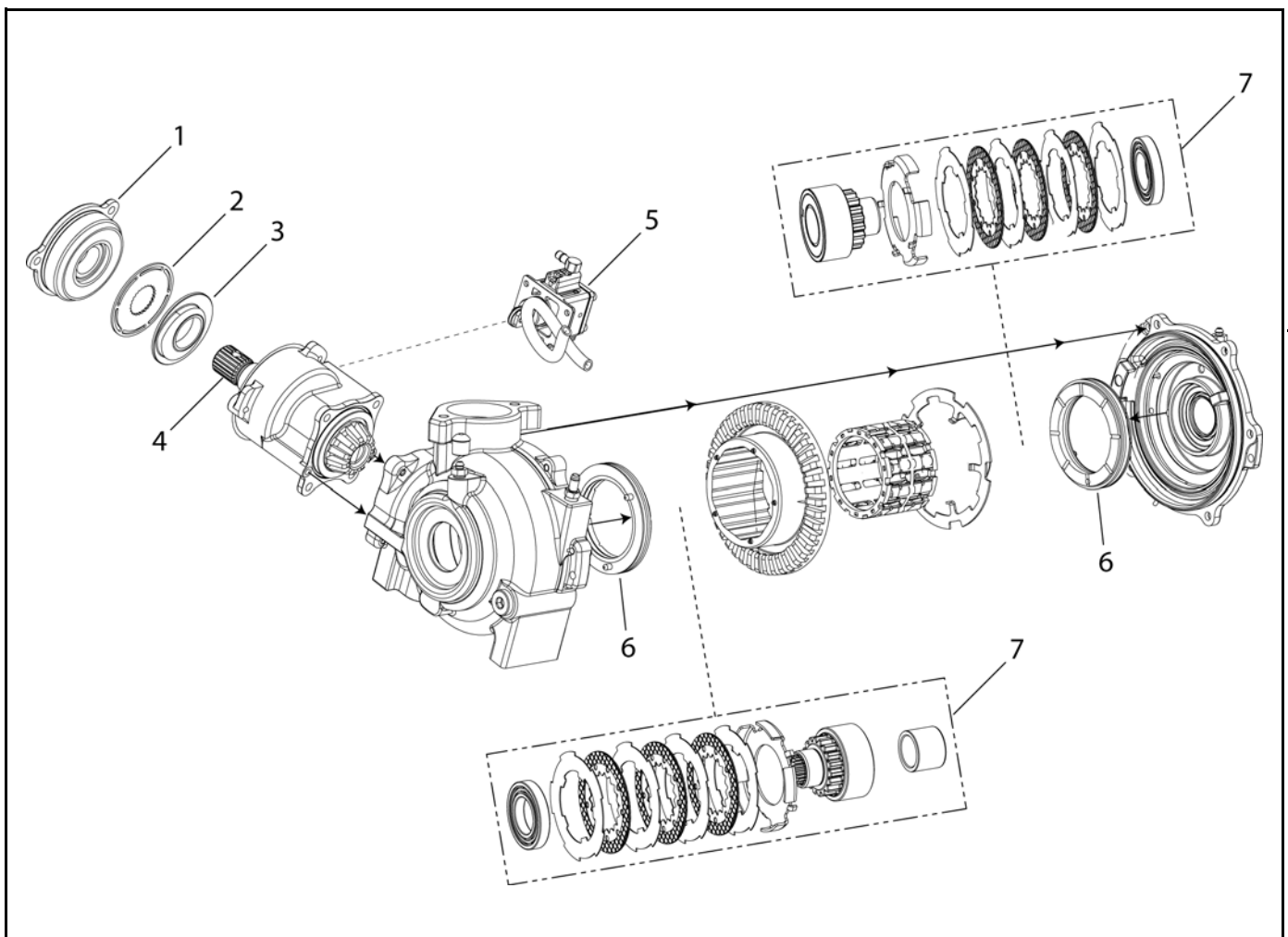

FINAL DRIVE

AWD Diagnosis

Symptom: AWD Will Not Engage

1. Check the gearcase AWD coil resistance. Measure between the Grey (C) and Brown/White (B) wires. The resistance value should be within specification.

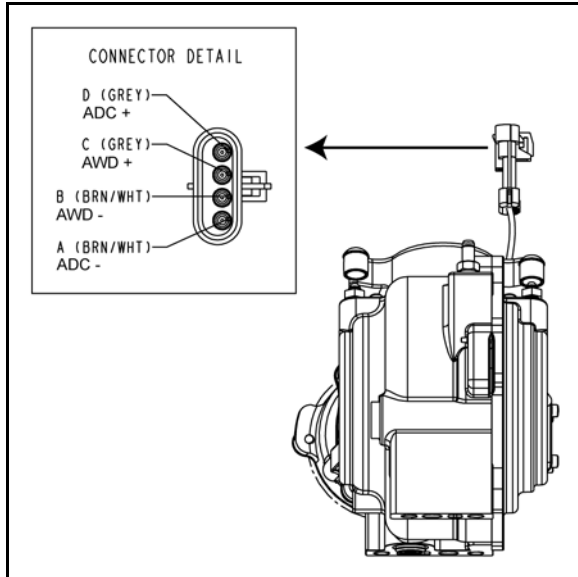

Front Gearcase Coil Resistance:

AWD (Pin B to Pin C): 24 Ω
ADC (Pin A to Pin D): 12 Ω

2. Turn on the ignition switch and AWD switch and place gear selector in High or Low gear. Check for minimum battery voltage at the chassis-side of the AWD/ADC connector. Measure between the Gray (C) and Brown/White (C) chassis wires that power the AWD coil. A minimum of 11 Vdc should be present.
3. If electrical tests are within specification, remove the front gearcase (see "Gearcase Removal") and inspect the internal components.
4. Inspect the armature plate for a consistent wear pattern. There should be two distinct wear bands (one band inside the other). If only one band of wear is present or if there is wear between the two bands, inspect the coil area as indicated in Step 5. A wear band with an interrupted wear mark may indicate a warped plate, which may cause intermittent operation.

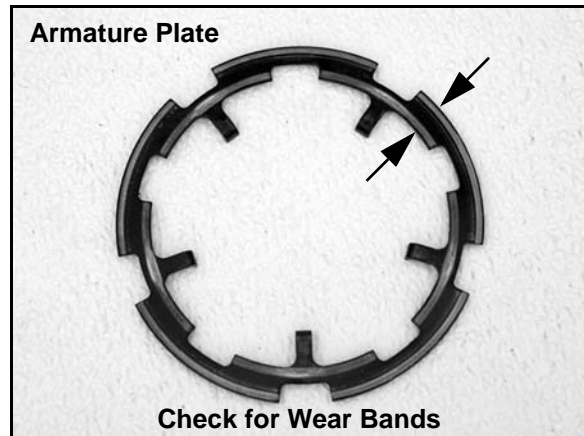

5. Check to make sure the AWD coil is seated in the U-shaped insert that is pressed into the gearcase cover. The top of the coil should be seated below the U-shaped insert. If the top of the coil is above the surface of the U-shaped insert it raises the armature plate, thereby increasing pole gap. If the pole gap increases, the coil will not be strong enough to engage the AWD system. If this is found, replace the cover plate assembly.

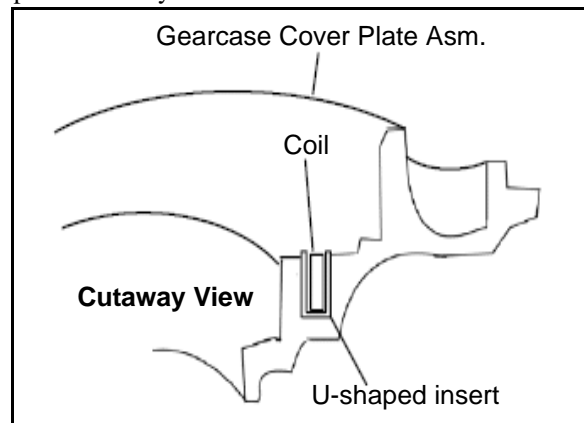

6. Inspect the rollers for nicks and scratches. The rollers must slide freely within the roll cage and H-springs.

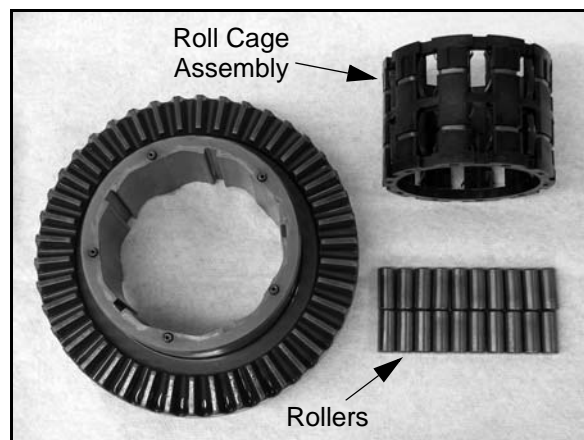

7. Inspect the roll cage assembly for cracks or excessive wear. If damaged, replace the roll cage assembly.

Gearcase Removal

1. Stop engine and place gear selector in Park.



⚠ CAUTION
 Serious injury may result if machine tips or falls. Be sure machine is secure before beginning this service procedure. Always wear eye protection.

2. Remove both front drive shafts from the front gearcase (see "FRONT DRIVE SHAFT - Removal").
3. Remove the front propshaft from the front gearcase input shaft (see "FRONT PROPSHAFT - Removal").
4. Disconnect the wire harness above the front gearcase and remove the plastic tie strap retaining the wires to the frame.



AWD Harness

5. Remove the front rack and remove the fuse/relay box from the frame to gain access to the ADC reservoir.
6. Remove the (2) screws retaining the ADC reservoir to the frame and pull the reservoir and clear hose out from the frame so it can be removed with the front gearcase.

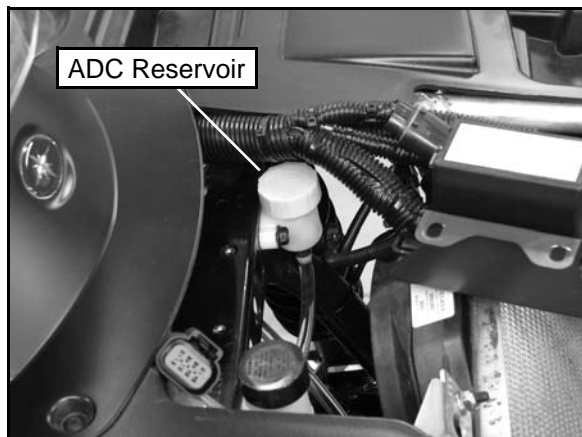

ADC Reservoir

7. Remove the cotter pin and nut from each tie rod end at the steering post frog.

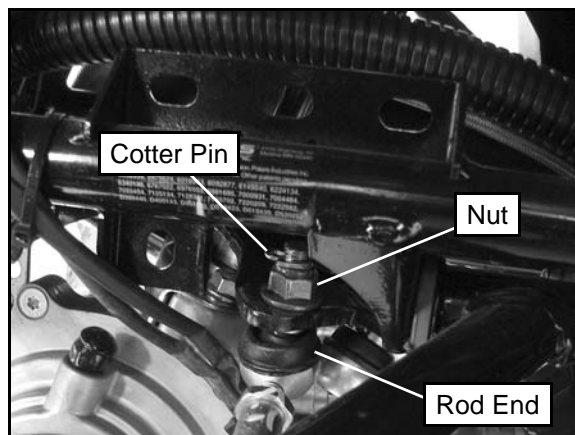

Cotter Pin

Nut

Rod End

8. Remove the (2) bolts retaining the lower steering post bracket to the front gearcase.

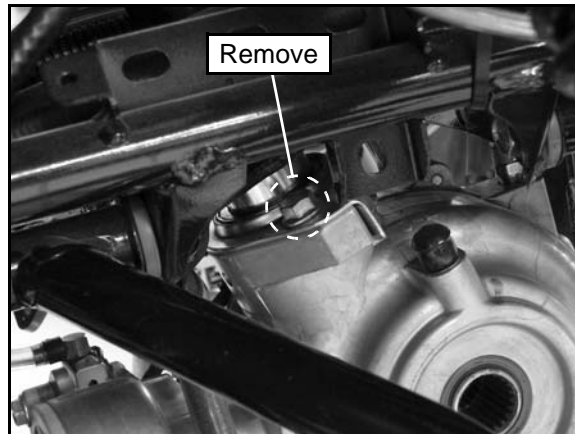

Remove

9. Remove the front cover and remove the (2) fasteners retaining the upper steering post bushing bracket.

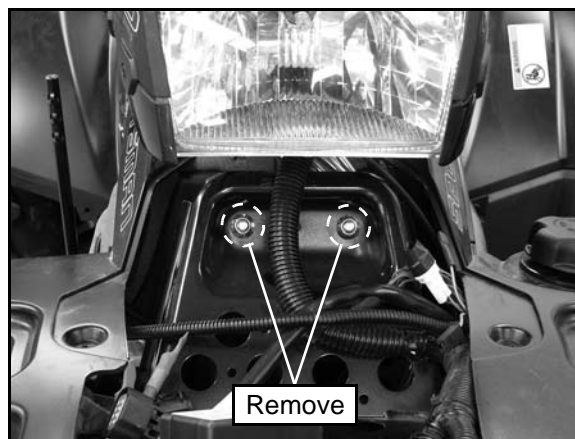

Remove

10. Lift the steering post assembly up from the front gearcase. Position the steering post toward the center of the vehicle to allow enough room for gearcase removal.

FINAL DRIVE

11. Remove the vent line and the (4) bolts securing the front gearcase to frame.

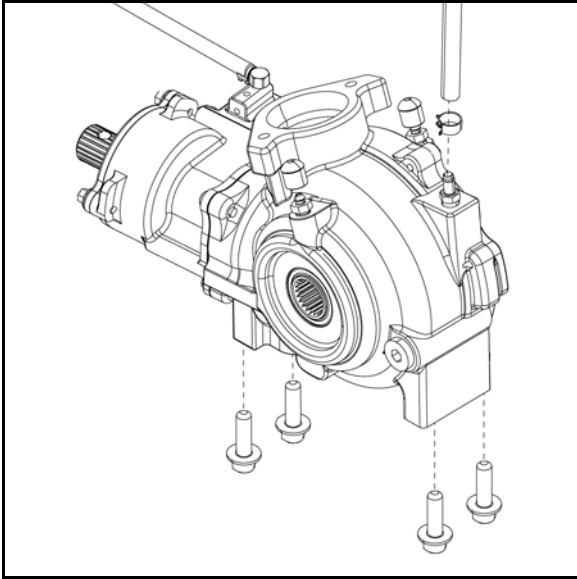

12. Lay the gearcase on its side (vent side up) and rotate it in the frame so the input shaft is facing you.

13. Remove the gearcase from the front LH wheel well area and carefully slide it between the upper and lower A-arms.



Gearcase Disassembly / Inspection

1. Drain and properly dispose of used lubricant. Remove any metal particles from the drain plug magnet.
2. Remove the (4) screws retaining the piston pump assembly to the gearcase and remove the pump.

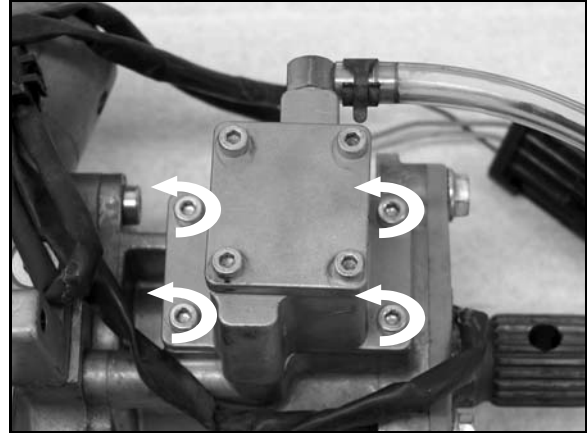

NOTE: Piston pump assembly is a non-serviceable item and should not be disassembled. Replace as an assembly if found to be damaged or non-working.

3. Remove the (6) screws retaining the cover plate assembly and open the wire retaining clip.

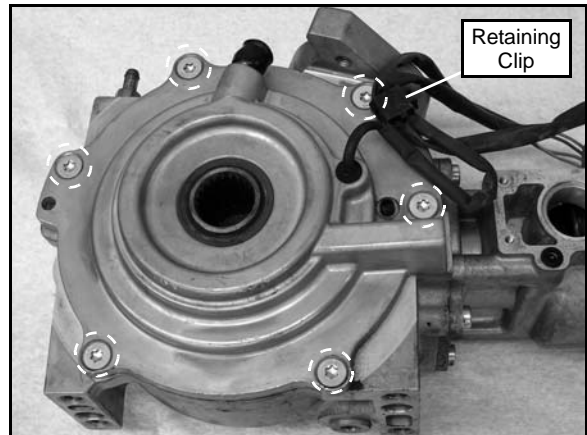

4. Remove the cover plate assembly. Inspect the thrust bearing (A) for wear.

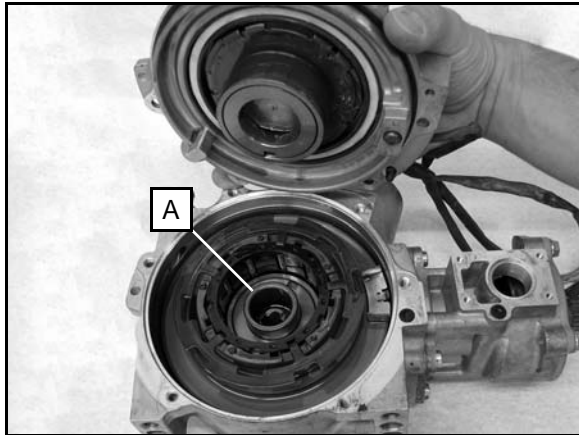

NOTE: Thrust bearing (A) located between the two output assemblies is pressed into the clutch pack and is not removable.

5. Remove the female output hub assembly. Inspect the bearings, contact surfaces and splines for signs of wear or damage. Visually inspect the clutch plate area. If plates are steel-on-steel, or if the friction material is worn, the assembly must be replaced.



NOTE: Excessive noise coming from the front drive on deceleration are key indicators of burnt or broken down front drive fluid.

6. Remove the armature plate. Inspect the armature plate for distortion or other damage (see "AWD Diagnosis"). Replace as required.

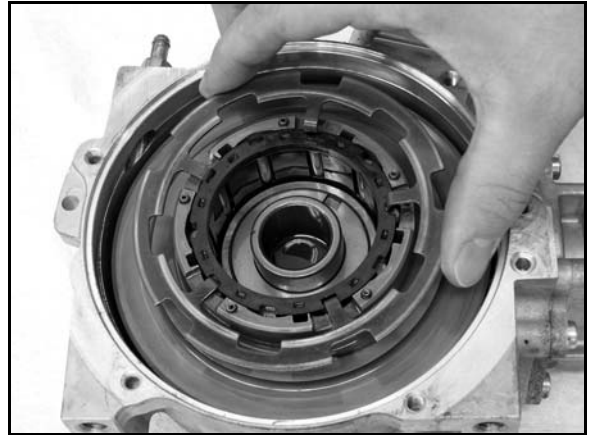

7. Remove the ring gear and roll cage from the gearcase as an assembly.



8. Remove the male output hub assembly. Inspect the bearings, contact surfaces and splines for signs of wear or damage. Visually inspect the clutch plate area. If plates are steel-on-steel, or if the friction material is worn, the assembly must be replaced.
9. Place a shop towel over the ring gear assembly and slowly remove the roll cage and rollers from the ring gear.

FINAL DRIVE

10. Inspect the rollers (B) for nicks, scratches and flat spots. Inspect the roll cage (C) for damage or cracks. The rollers must slide up and down freely within the roll cage surfaces. Inspect the ring gear (D) for consistent wear patterns. Surfaces should be free of nicks or burrs.

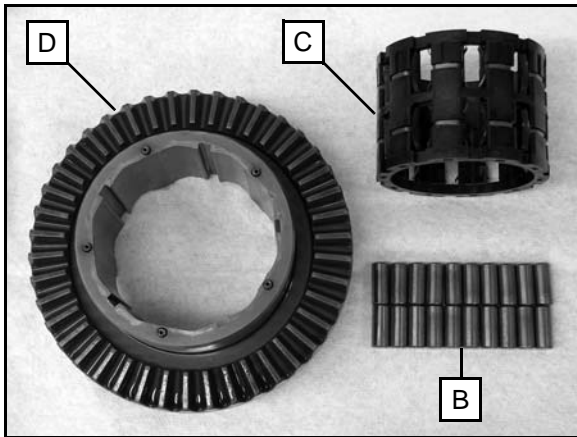

11. Inspect roll cage sliding surfaces. These surfaces must be clean and free of nicks, burrs or scratches.
12. Remove and inspect the H-springs (E). If the spring legs appear to be flattened or damaged, replace the roll cage and H-springs as an assembly.

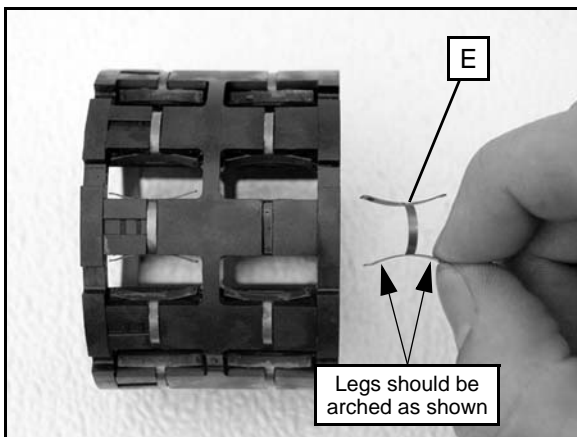

IMPORTANT: Refer to the “Electronic Parts Catalog” for individual part availability. Most parts are to be replaced as an assembly or as a complete kit.

13. Inspect the armature plate for a consistent wear pattern. Uneven wear of the armature plate indicates a warped plate, which may cause intermittent operation (refer to “AWD Diagnosis” for inspection).

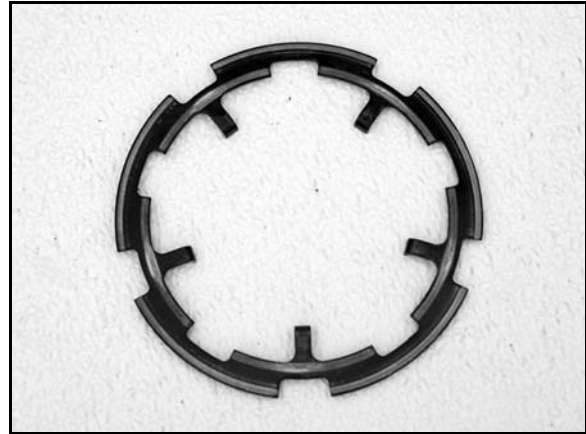

14. Inspect the magnetic coil (F) in the cover plate assembly (refer to “AWD Diagnosis” for inspection).

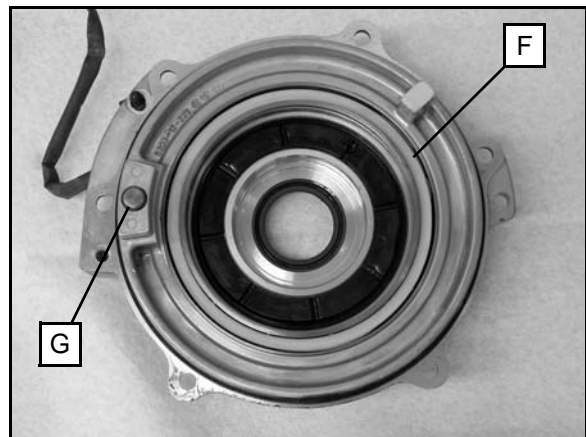

15. Inspect the backlash thrust button (G) and thrust pad for excessive wear.

NOTE: Ring gear backlash is set at the factory. No adjustment is required unless the front cover is replaced or the backlash thrust pad screw is removed. Refer to “Setting Ring Gear Backlash” later in this chapter for details on backlash setting.

16. Remove the (3) bolts retaining the input cover.

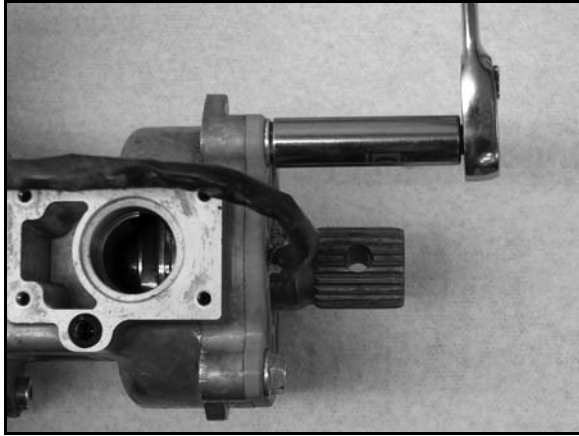

17. Remove the cover (H), armature plate (J) and cam (K).

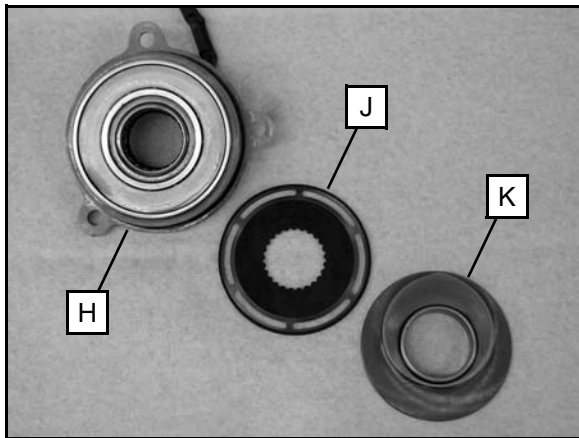

18. Inspect the armature plate (J) and cam (K) for excessive wear or damage. If replacement is required, replace the armature plate and cam as an assembly.
19. Inspect the magnetic coil (L) and needle bearing (M) located in the input cover assembly. If replacement is required, replace the input cover as an assembly.

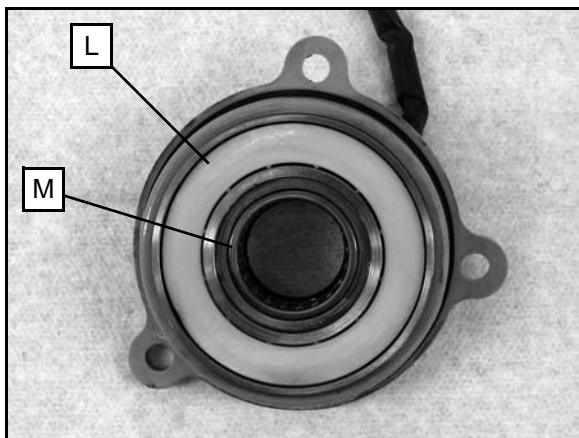

20. Remove the (4) screws that retain the pump neck assembly to the main gearcase.

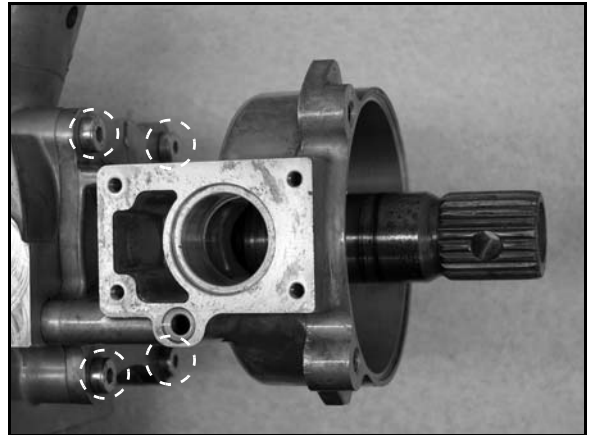

21. Remove the neck and input shaft assembly from the main gearcase.

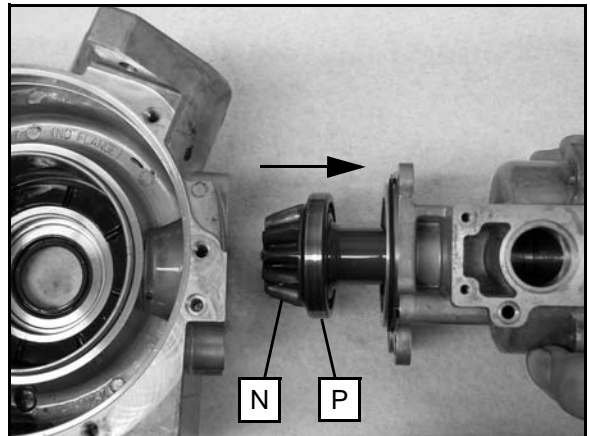

22. Inspect the pinion gear (N) for chipped, broken, or missing teeth. Inspect the input shaft bearing (P) for signs of wear. The bearing can be replaced separate from the input shaft.

IMPORTANT: Refer to the "Electronic Parts Catalog" for individual part availability. Most parts are to be replaced as an assembly or as a complete kit.

FINAL DRIVE

Gearcase Assembly

NOTE: Refer to the photos used in the “Gearcase Disassembly / Inspection” procedure when needed, while assembling the front gearcase.

1. Thoroughly clean all gearcase components before beginning reassembly.
2. Install new seals and O-rings as shown (included in the *Seal Repair Kit*).

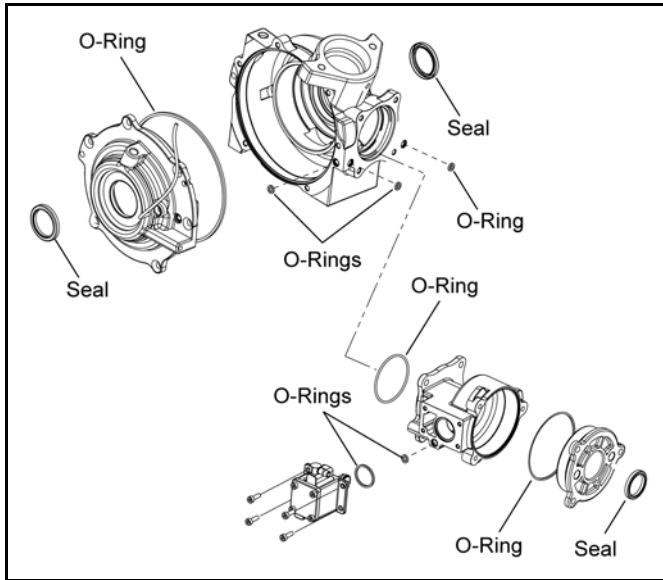

3. Apply assembly grease to the seal lips to prevent from damaging the seals upon assembly.
4. Install the input shaft assembly.
5. Install the neck onto the main gearcase using new O-rings. Torque the screws to specification.

 = T
Gearcase Neck Retaining Screws: 7-11 ft. lbs. (9-15 Nm)

6. Install the cam, armature plate and input cover assembly with a new O-ring.

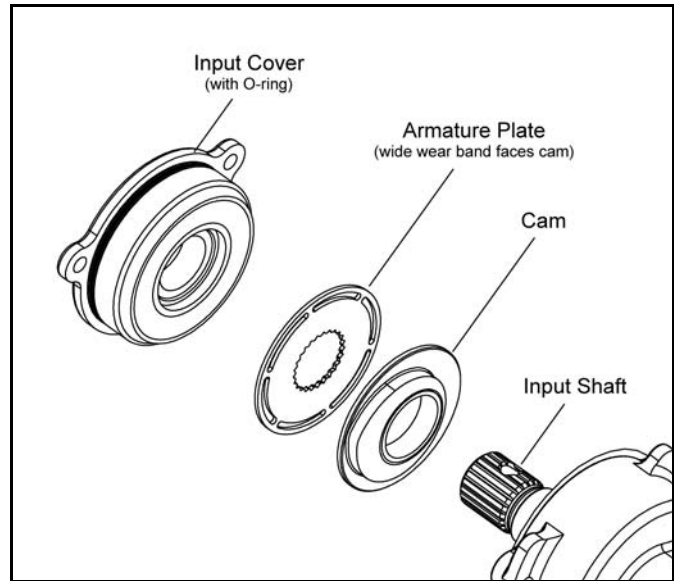

7. Torque the input cover screws to specification.

 = T
Input Cover Screws: 7-11 ft. lbs. (9-15 Nm)

8. Install the roll cage and rollers into the ring gear. Insert the rollers as the roll cage is installed.

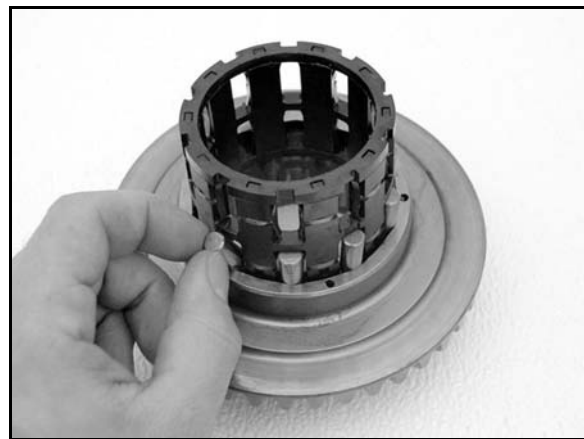

9. Install the male output hub assembly into the main gearcase.

IMPORTANT: Take care not to damage the seal lip or seal spring while installing the output hub.

10. Place the ring gear and roll cage assembly into the main gearcase.

NOTE: Rotate the ring gear to align the locating pins and holes during installation.

11. Install the armature plate. Verify the armature plate tabs align with tab recesses in the roll cage.

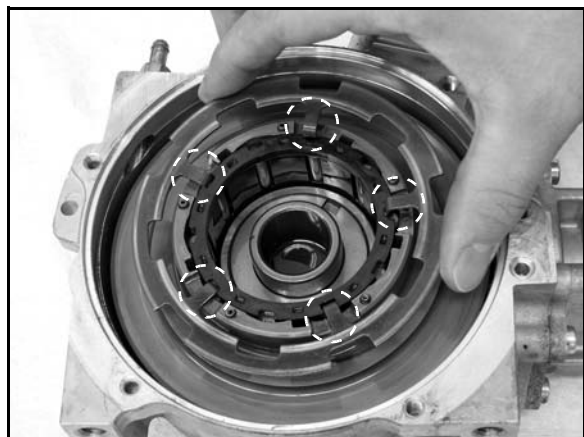

12. Install the female output hub assembly into the roll cage.

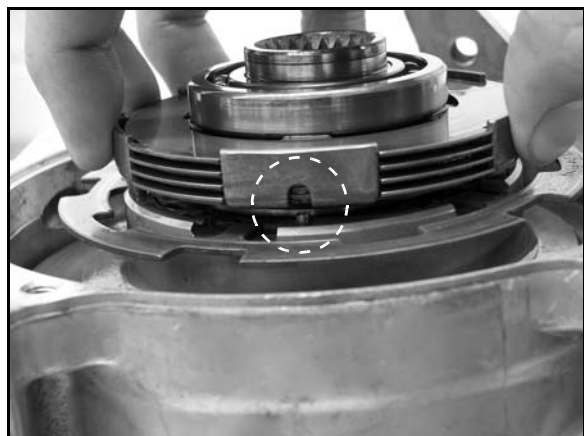

NOTE: Rotate the output hub to align the locating pins and holes during installation.

13. Install the large O-ring onto the cover plate and small O-ring onto the main gearcase.

14. Lightly crimp the thrust pad to hold the pad on the cover plate during installation.

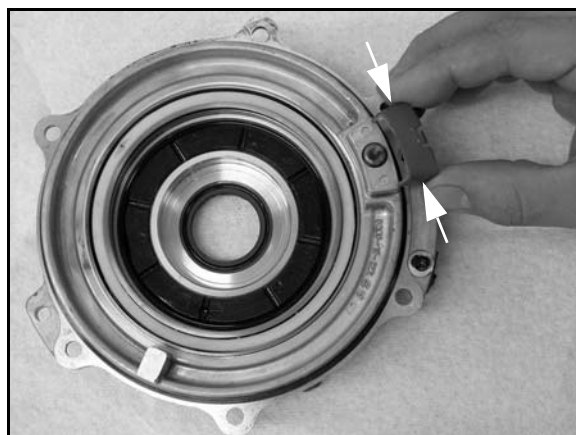

15. Place the cover plate assembly on the main gearcase and install the (6) screws. Torque screws to specification.

IMPORTANT: Take care not to damage the seal lip or seal spring while installing the cover plate.

 = T
Cover Plate Screws: 7-11 ft. lbs. (9-15 Nm)

16. Install the piston pump assembly with new O-rings. Torque the screws to specification.

 = T
Pump Assembly Screws: 15 in. lbs. (1.7 Nm)

IMPORTANT: If the cover plate was replaced or if the backlash set screw was repositioned, proceed to the "Setting Ring Gear Backlash" procedure.

FINAL DRIVE

Setting Ring Gear Backlash

NOTE: Ring gear backlash is set at the factory. No adjustment is required, unless the front cover is replaced or the backlash screw has been tampered with.

1. The backlash screw has locking agent that holds it into place. Use a heat gun to lightly heat up the locking agent on the screw.



2. Using an Allen wrench, turn the backlash screw out 3-4 turns. Re-apply Loctite 262™ onto the bottom screw threads.

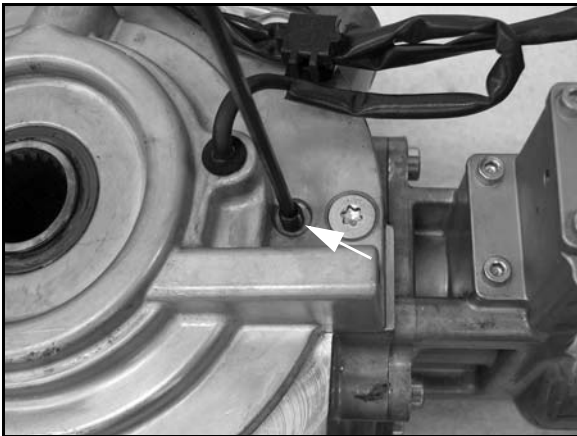

3. Turn the screw in until it is lightly seated, then turn the screw out 1/4 turn.
4. Set the gearcase upright. Rotate the input shaft at least 4 times. This ensures the ring gear completes one full rotation.

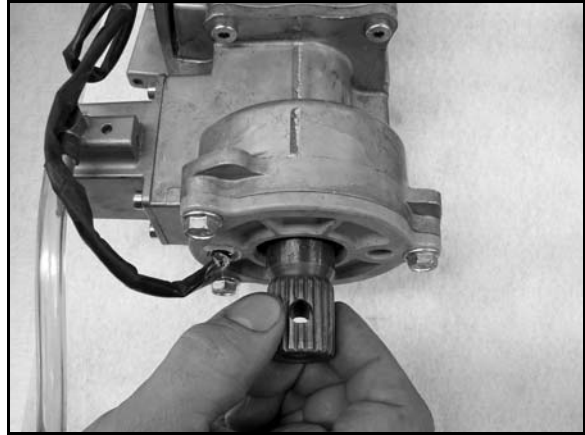

5. If a tight spot is felt during rotation, loosen the backlash screw another 1/8 turn and perform step 4 again. Repeat this procedure until the pinion shaft rotates smoothly 4 times (1 revolution of ring gear).

Gearcase Installation

1. Install the gearcase back into the vehicle through the front left wheel well, between the upper and lower A-arms.

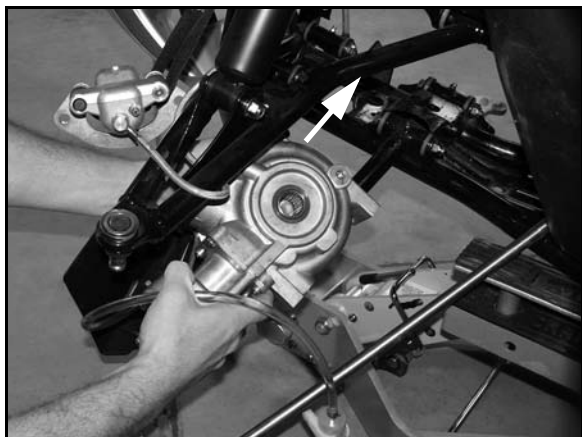

2. Route the ADC reservoir and clear hose up through the center of the chassis. Do not allow hose to become pinched.



3. Mount the reservoir to the frame using the (2) previously removed screws.
4. Install the vent line and the (4) bolts that secure the front gearcase to frame. Torque bolts to specification.

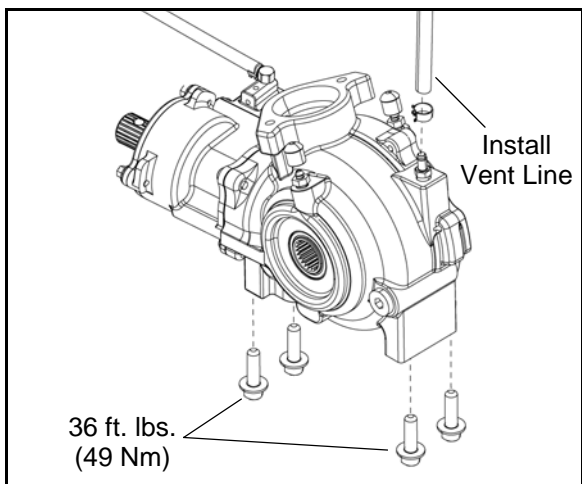

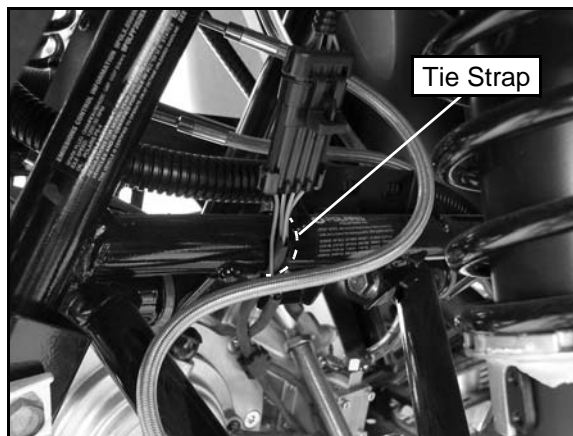

 = T
Front Gearcase Mounting Bolts: 36 ft. lbs. (49 Nm)

5. Connect and route the AWD wire harness along the frame and install a plastic tie strap to attach it to the frame.

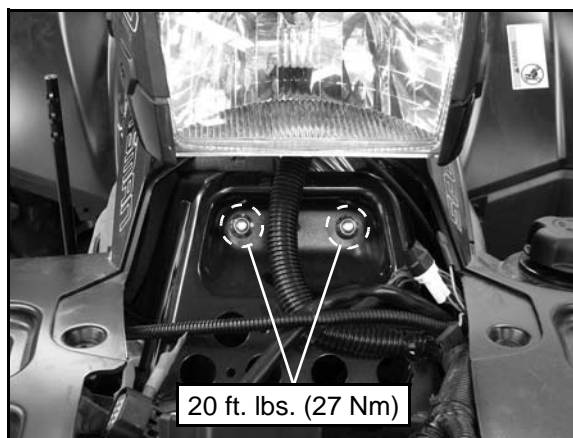

6. Place the steering post and bearing into the front gearcase.
7. Reinstall the upper steering post bushing bracket and torque the (2) fasteners to specification.



 = T
Steering Post to Bulkhead Bolts: 20 ft. lbs. (27 Nm)

FINAL DRIVE

8. Install the (2) bolts securing the lower portion of the steering post to the gearcase and torque to specification.

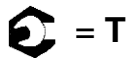
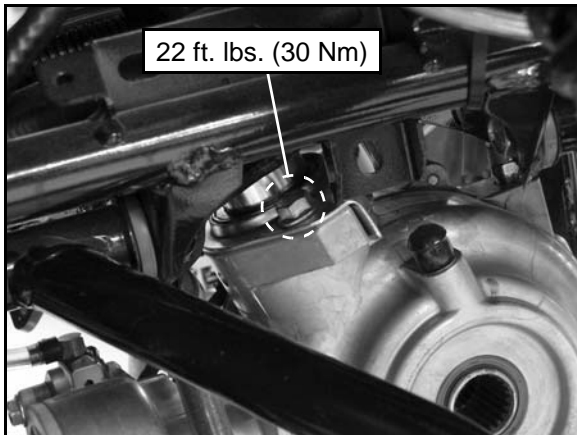

Steering Post to Gearcase Bolts:
22 ft. lbs. (30 Nm)

9. Install the steering tie rod ends into the steering frog. Torque the tie rod end fasteners to specification and install new cotter pins.

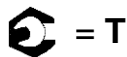
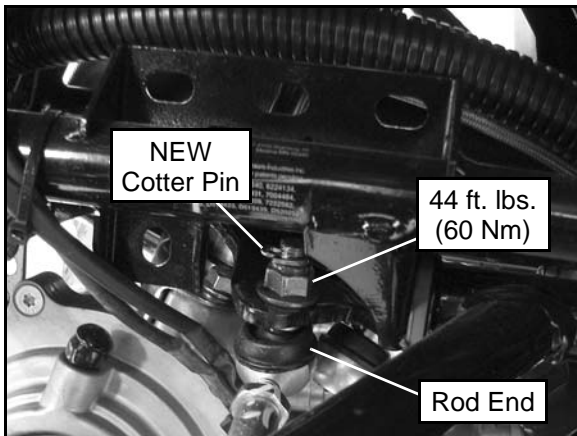

Tie Rod to Steering Frog:
44 ft. lbs. (60 Nm)

10. Install the front cover and front rack (see Chapter 9).

11. Install the front propshaft onto the front gearcase input shaft (see "FRONT PROPSHAFT - Installation").

12. Install both front drive shafts into the front gearcase (see "FRONT DRIVE SHAFT - Installation").

13. Reinstall the front gearcase drain plug with a new O-ring and torque to specification.

14. Add the recommended amount of fluid through the fill hole. Maintain the fluid level even with the bottom threads of the fill plug hole.

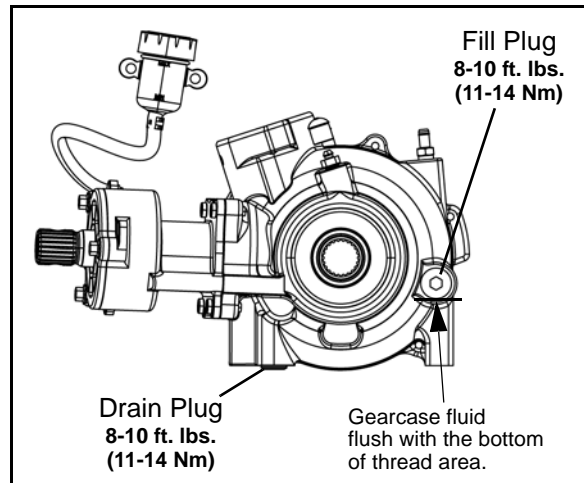

Recommended Front Gearcase Fluid:
Premium LT Demand Drive Fluid
(PN 2876251) (Quart)

Capacity: 9.3 oz. (275 ml)

15. Reinstall fill plug with a new O-ring and torque to specification.

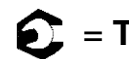

Drain / Fill Plug Torque:
8-10 ft. lbs. (11-14 Nm)

16. Check for external leaks.

17. If the ADC system was serviced, it must be properly bled (see "ADC System Fluid Bleeding").

ADC System Fluid Bleeding

1. Position the vehicle on a level surface and allow the vehicle to sit for at least 30 minutes.
2. Thoroughly clean the areas around the ADC reservoir and bleeder valves.
3. Remove the reservoir cap and diaphragm assembly.
4. Make sure the fluid inside the reservoir is free of debris. If any debris is found, use a clean shop towel or suction device to remove it from the reservoir.

NOTE: Debris in the reservoir may result in inadequate bleeding and reduced performance of the system.

5. Begin the bleeding process by filling reservoir to the "MAX" level with clean ADC Front Drive Fluid.

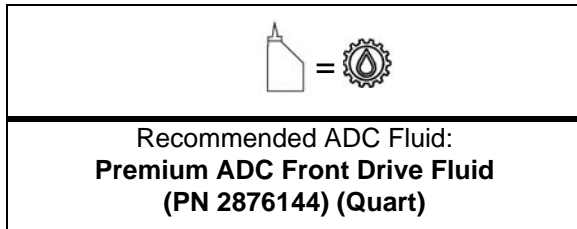

6. Locate bleeder valves found on each side of the front gearcase and remove the protective caps.

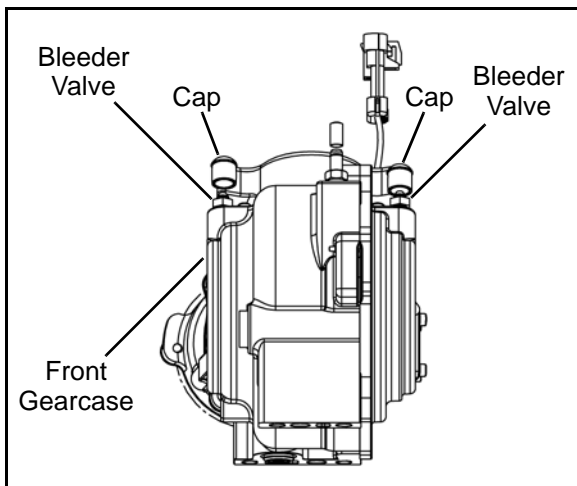

7. Attach a clean clear hose to one of the bleeder valves.
8. Slowly loosen the valve (counter-clockwise) and allow fluid and trapped air to flow from the fitting.

IMPORTANT: Do not allow ADC fluid in reservoir to drop below the "MIN" fill line. Close bleeder valve before the fluid level drops below the "MIN" fill line. Refilling an empty reservoir will result in air pockets becoming trapped.

9. Close the valve when clean (bubble-free) fluid begins to flow from the valve.
10. Repeat steps 7-9 on the remaining bleeder valve.
11. Torque the bleeder valves to specification and reinstall the protective caps.

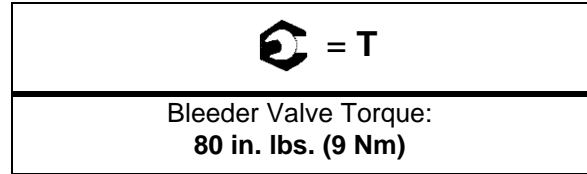

12. Fill reservoir to a level midway between "MAX" and "MIN" fill lines. Verify no debris is found in reservoir fluid.
13. Install the reservoir cap and diaphragm securely and wipe clean any fluid residue.

FINAL DRIVE

REAR BEARING CARRIER

Inspection / Removal

1. Elevate rear of vehicle and safely support machine under the frame area.



Serious injury may result if machine tips or falls. Be sure machine is secure before beginning this service procedure. Always wear eye protection.

2. Check bearings for side play by grasping the top and bottom of the tire firmly and checking for movement. The tire should rotate smoothly without binding or rough spots.
3. Remove the (4) wheel nuts and remove the rear wheel.
4. Remove the cotter pin and loosen the rear wheel hub castle nut. Remove the nut, and (2) cone washers from the rear wheel hub assembly.

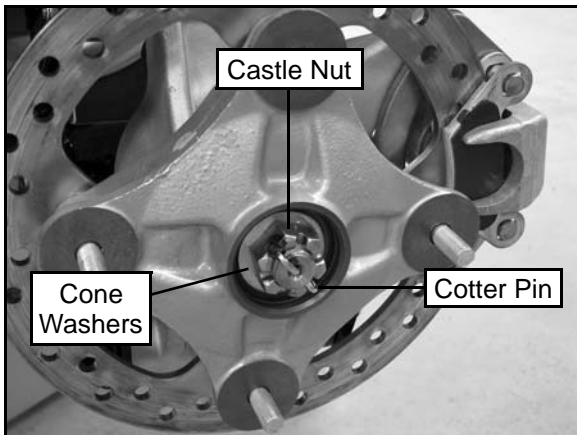

5. Remove the two brake caliper mounting bolts. **CAUTION:** Do not hang the caliper by the brake line. Use wire to hang caliper to prevent damage to the brake line.

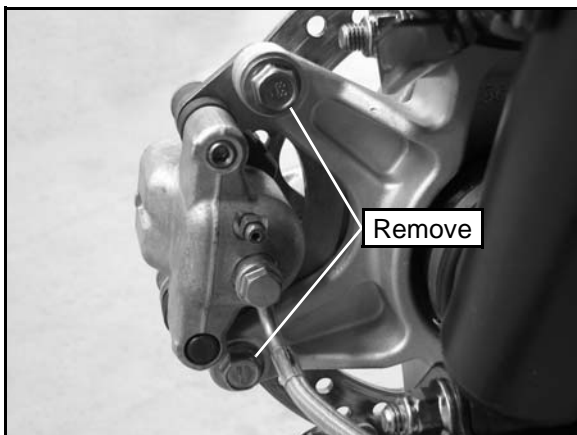

6. Remove the rear wheel hub assembly.

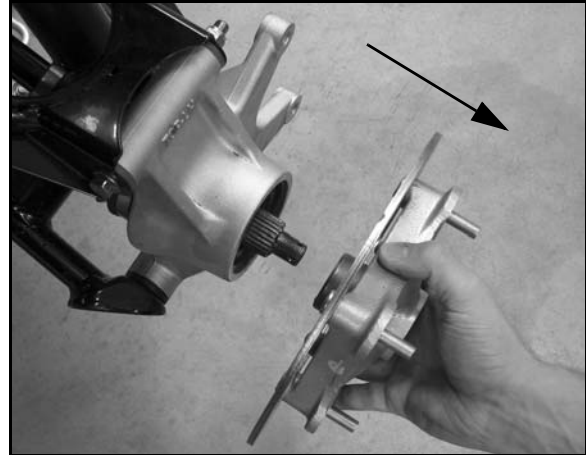

7. Remove the bolts that attach the rear bearing carrier to the upper and lower A-arms.

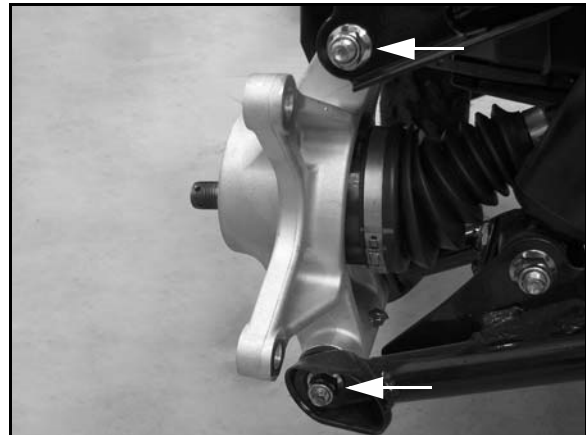

8. Remove the bearing carrier from the rear drive shaft.

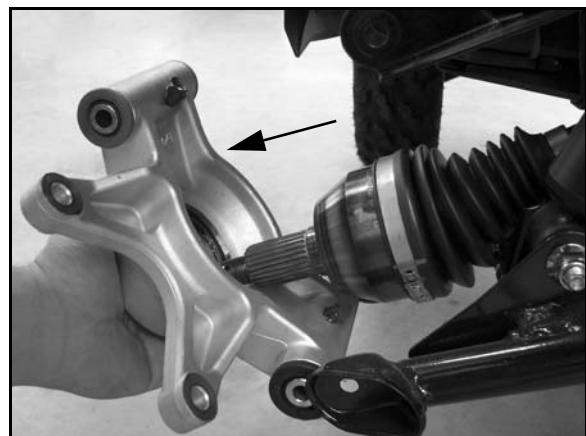

9. Rotate bearing by hand and check for smooth rotation. Visually inspect bearing for moisture, dirt, or corrosion.

NOTE: Due to extremely close tolerances and minimal wear, the bearings must be inspected visually, and by feel. While rotating bearings by hand, inspect for rough spots, discoloration, or corrosion. The bearings should turn smoothly and quietly, with no detectable up and down movement and minimal movement sideways between inner and outer race.

10. Replace bearing if moisture, dirt, corrosion, or roughness is evident.

Bearing Replacement

Bearing Removal

1. Remove the outer retaining ring from the bearing carrier.

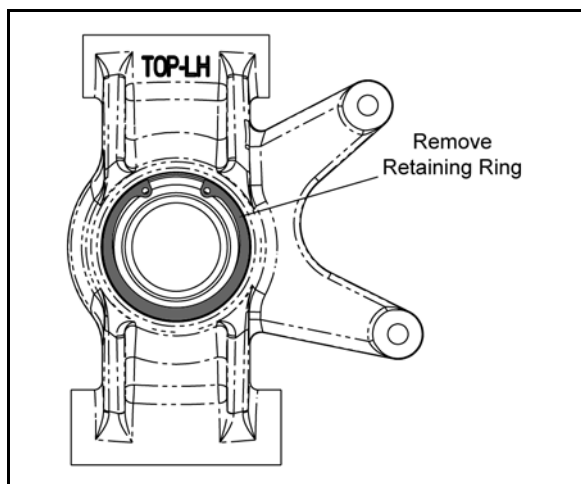

2. Support the bearing carrier in an arbor press and remove the bearing by pressing it out from the back side.

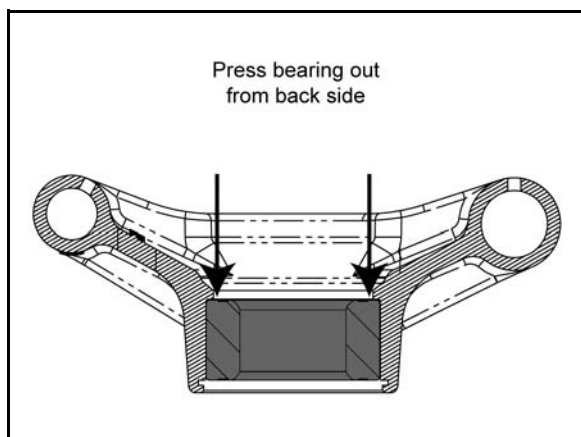

3. Inspect the bearing carrier housing for scratches, wear or damage. Replace rear bearing carrier if damaged.

Bearing Installation

4. Thoroughly clean the rear bearing carrier housing and the outer race on the new bearing. Be sure that all oil residue has been removed from each surface.
5. Support the bottom of the bearing carrier housing.



CAUTION

Use an arbor and press only on the outer race or bearing damage may occur.

6. Apply **Loctite® 603™** retaining compound to the outer circumference of the new bearing race and carefully press the new bearing into the bearing carrier housing.

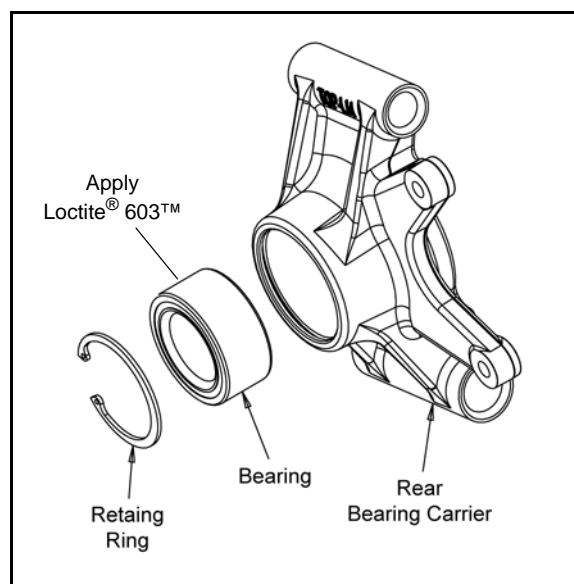

NOTE: Use care to not allow any of the Loctite® compound to get in the bearing.

7. Wipe the housing clean of any excess compound and install the snap ring.

FINAL DRIVE

Bushing Replacement

1. Check bearing carrier bushings and shafts for excessive wear or damage.
2. If replacement is required, slide shafts out and remove the bushings with a drift punch.

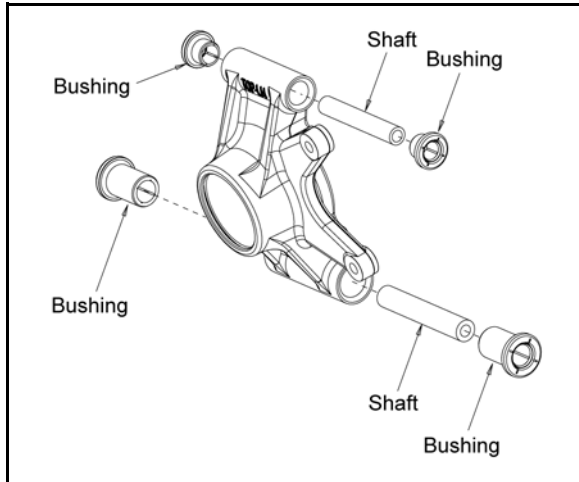

3. Thoroughly clean the bearing carrier and inspect for excessive wear or damage. Replace rear bearing carrier if damaged.
4. Install new shafts and bushings. Press the bushings into the bearing carrier until they are flush with the mating surface.
5. Grease the the rear bearing carrier fittings after it has been installed and the rear A-arms have been attached.

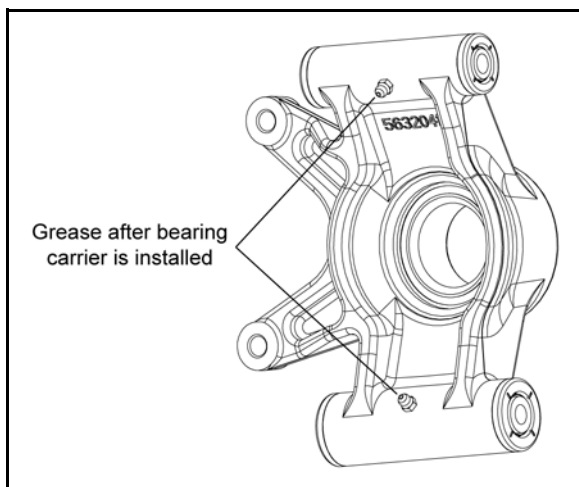

Installation

1. Install drive shaft axle through the backside of the bearing carrier. Be sure bushings and pivot tubes are installed.

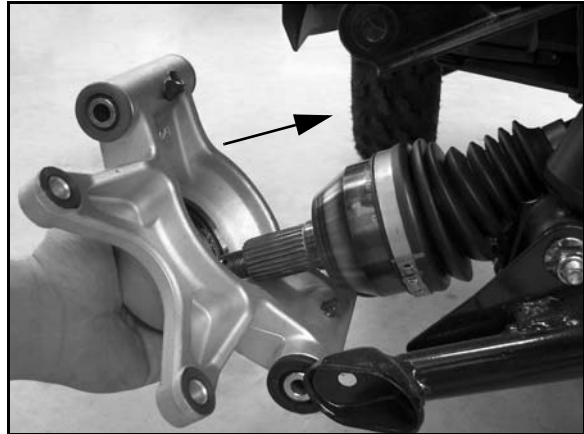

2. Install the fasteners that attach the rear bearing carrier to the upper and lower A-arms. Torque bolts to specification.

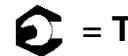
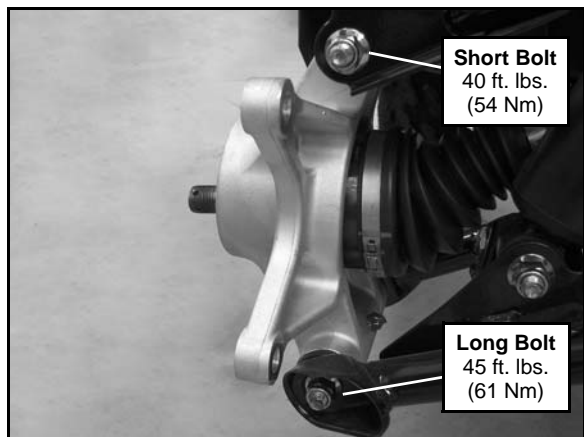

Rear Bearing Carrier Bolts:
Upper: 40 ft. lbs. (54 Nm)
Lower: 45 ft. (61 Nm)

3. Apply grease to drive shaft axle splines.
4. Install rear wheel hub assembly, cone washers, and hand tighten the castle nut. Install washers with domed side out.

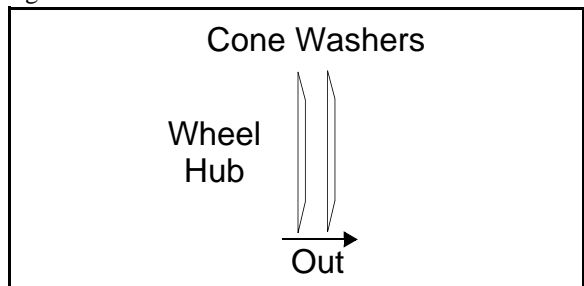

5. Install the brake caliper and torque the new mounting bolts to specification.

 **CAUTION**

New bolts have a pre-applied locking agent which is destroyed upon removal. Always use new brake caliper mounting bolts upon assembly.

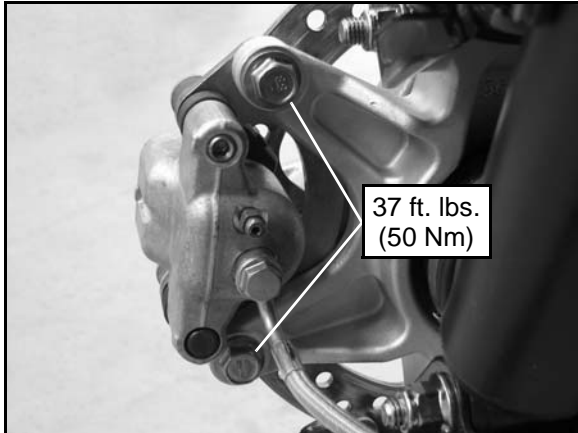

 = T

Rear Caliper Mounting Bolts:
37 ft. lbs. (50 Nm)

6. Torque wheel hub nut to specification and install a new cotter pin. Tighten nut slightly if necessary to align cotter pin holes.

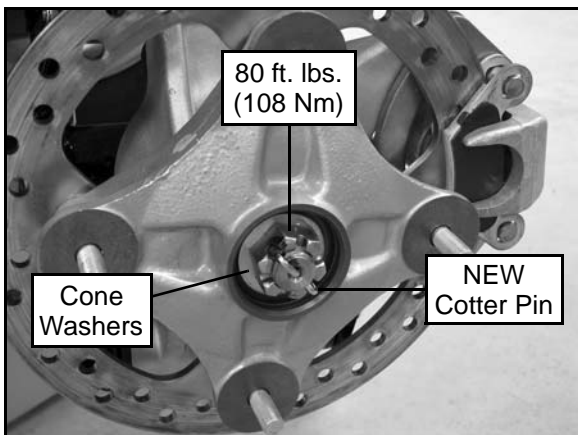

 = T

Wheel Hub Castle Nut:
80 ft. lbs. (108 Nm)

7. Install the rear wheel and (4) wheel nuts. Torque wheel nuts to specification.

 = T

Wheel Nuts:
Steel Wheels: 45 ft. lbs. (61 Nm)
Aluminum Wheels: 75 ft. lbs. (102 Nm)

8. Rotate wheel and check for smooth operation. Bend both ends of cotter pin around end of spindle in different directions.

FINAL DRIVE

REAR DRIVE SHAFT

Removal

1. Elevate rear of vehicle and safely support machine under the frame area.



Serious injury may result if machine tips or falls. Be sure machine is secure before beginning this service procedure. Always wear eye protection.

2. Remove the (4) wheel nuts and remove the rear wheel.
3. Remove the cotter pin and loosen the rear wheel hub castle nut. Remove the nut, and (2) cone washers from the rear wheel hub assembly.

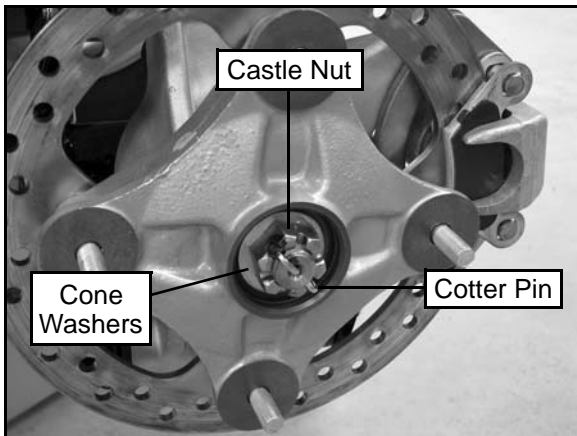

4. Remove the two brake caliper mounting bolts. **CAUTION:** Do not hang the caliper by the brake line. Use wire to hang caliper to prevent damage to the brake line.

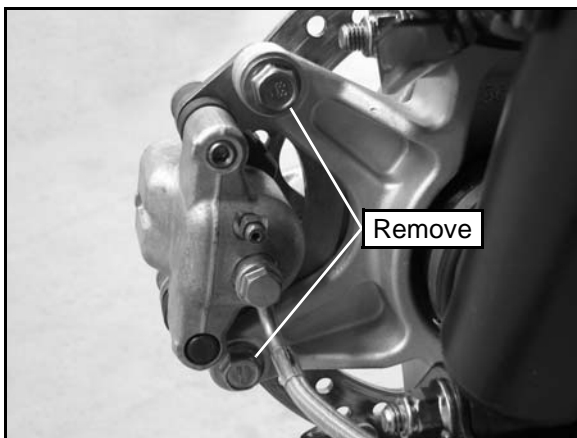

5. Remove the rear wheel hub assembly.

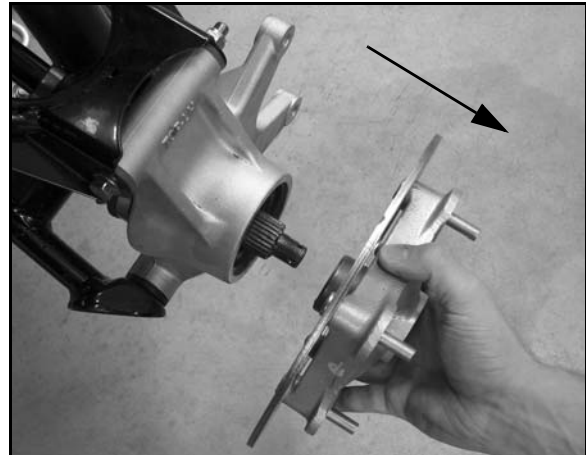

6. Remove the bolt that attaches the upper A-arm to the rear bearing carrier.

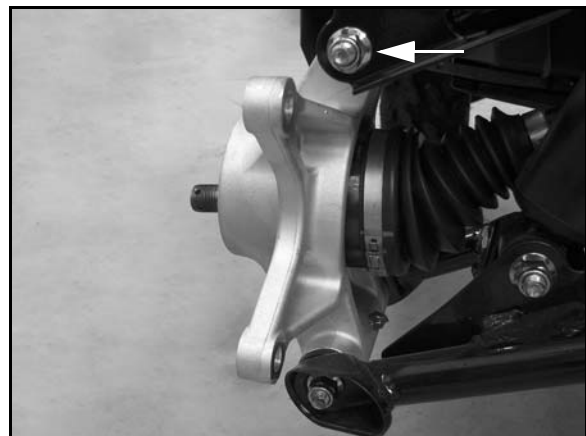

7. Tilt the top portion of the bearing carrier down and pull the rear drive shaft out from the bearing carrier.

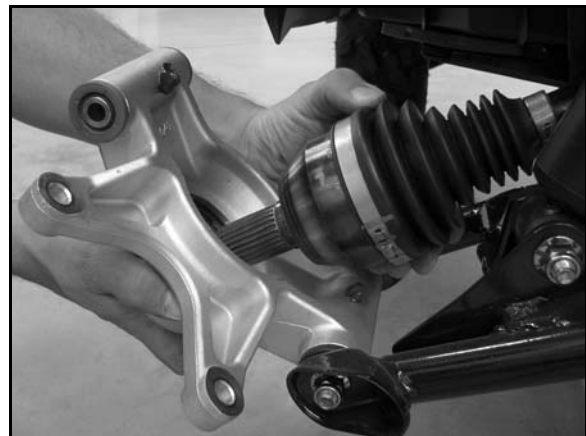

- Grasp the rear drive shaft and pull sharply outward on the shaft to disengage it from the rear gearcase.



- Inspect the axle splines and CV boots for any damage.
- Refer to the "DRIVE SHAFT SERVICE" procedure if repairing the drive shaft.

Installation

- Install a new spring ring on the end of the drive shaft and apply an anti-seize compound to the splines.

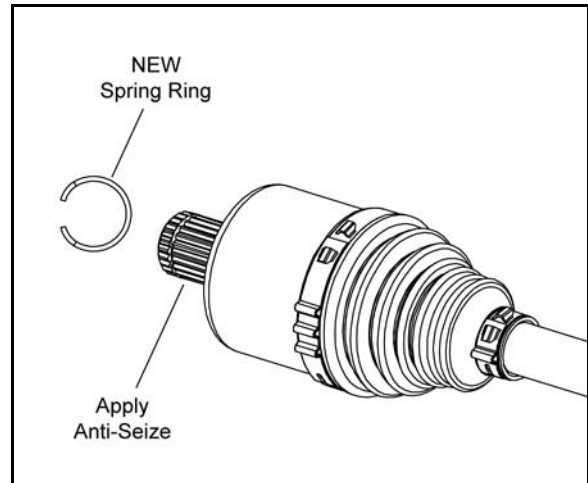

- Align the splines of the drive shaft with the rear gearcase and reinstall the drive shaft. Use a rubber mallet to tap on the outboard end of the drive shaft if necessary.

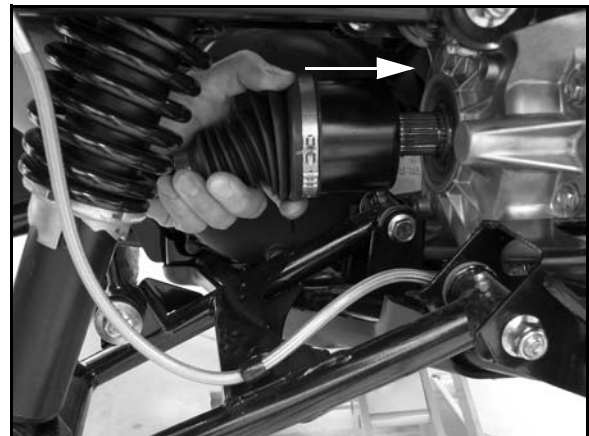

- Install the drive shaft into the rear bearing carrier.
- Refer to the "REAR BEARING CARRIER - Installation" procedure within this chapter to properly reassemble the vehicle.

FINAL DRIVE

DRIVE SHAFT SERVICE

Drive Shaft / CV Joint Handling Tips

Care should be exercised during drive shaft removal or when servicing CV joints. Drive shaft components are precision parts.

Cleanliness and following these instructions is very important to ensure proper shaft function and a normal service life.

- The complete drive shaft and joint should be handled by getting hold of the interconnecting shaft to avoid disassembly or potential damage to the drive shaft joints.
- Over-angling of joints beyond their capacity could result in boot or joint damage.
- Make sure surface-ground areas and splines of shaft are protected during handling to avoid damage.
- Do not allow boots to come into contact with sharp edges or hot engine and exhaust components.
- The drive shaft is not to be used as a lever arm to position other suspension components.
- Never use a hammer or sharp tools to remove or to install boot clamps.
- Be sure joints are thoroughly clean and that the proper amount and type of grease is used to refill when joint boots are replaced and when joints are cleaned. Refer to text for grease capacity of CV joints and CV joint boots.

Outer CV Joint / Boot Replacement

1. Using a side cutters, cut away and discard the boot clamps.



2. Remove the large end of the boot from the CV joint and slide the boot down the shaft.

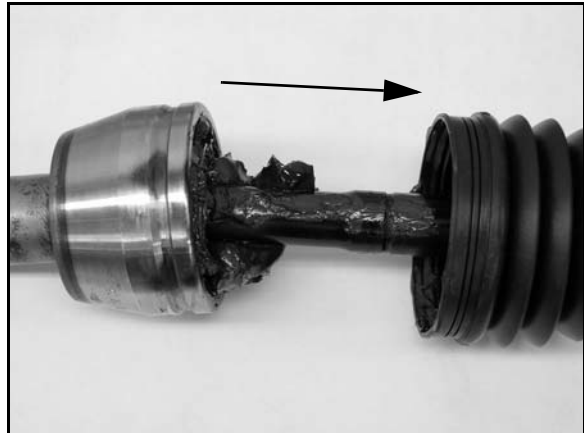

3. Clean the grease from the face of the joint.
4. Place the drive shaft in a soft-jawed vise.
5. Using a soft-faced hammer, or brass drift, strike the inner race of the joint to drive the joint off the drive shaft. Be sure to tap evenly around the joint to avoid binding.

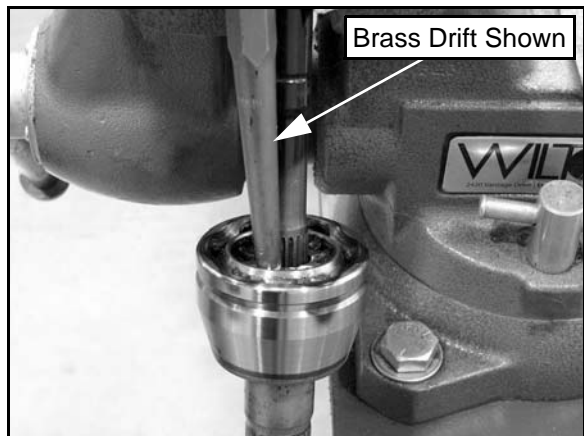

IMPORTANT: Tap on inner race only!

6. Make sure the circlip is on the shaft and not left in the joint.

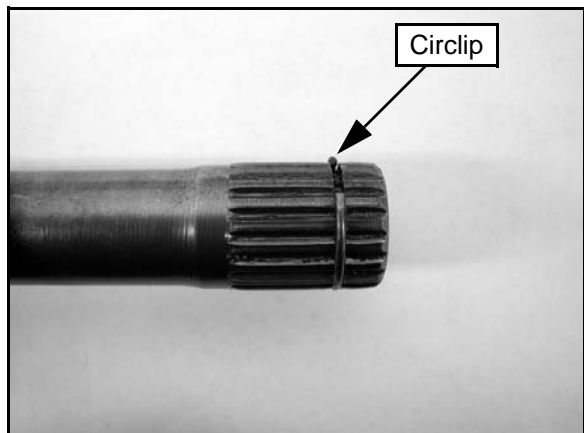

7. Remove the CV boot from the shaft.

CAUTION

Complete disassembly of the CV joint is NOT recommended. The internal components are a precision fit and develop their own characteristic wear patterns. Intermixing the internal components could result in looseness, binding, and/or premature failure of the joint.

IMPORTANT: If the grease in the joint is obviously contaminated with water and/or dirt, the joint should be replaced.



8. Thoroughly clean the joint with an appropriate solvent and dry the joint to prevent any residual solvent from being left in the joint upon reassembly.
9. Visually inspect the joint by tilting the inner race to one side to expose each ball. Severe pitting, galling, play between the ball and its cage window, any cracking or damage to the cage, pitting or galling or chips in raceways call for joint replacement.

NOTE: Shiny areas in ball tracks and on the cage spheres are normal. Do not replace CV joints because parts have polished surfaces. Replace CV joint only if components are cracked, broken, worn or otherwise unserviceable.

10. Clean the splines on the end of the shaft and apply a light coat of grease prior to reassembly.
11. Slide the small boot clamp and boot (small end first) onto the drive shaft and position the boot in it's groove machined in the shaft.
12. Install a NEW circlip on the end of the shaft.

13. Grease the joint with the special CV joint grease provided in the boot replacement kit. Fill the cavity behind the balls and the splined hole in the joint's inner race. Pack the ball tracks and outer face flush with grease. Place any remaining grease into the boot.

CAUTION

The grease provided in the replacement kit is specially formulated for wear resistance and durability. DO NOT use substitutes or mix with other lubricants.

NOTE: The amount of grease that's provided is pre-measured, so use all the grease.

Boot Replacement Grease Requirements:

Grease Only Service Kits

PN 1350059 - 20g / PN 1350046 - 30g / PN 1350047 - 50g

Outer CV Joint Capacity:

Front - 80g / Rear - 90g

14. Slide the joint onto the drive shaft splines and align the circlip with the lead-in chamfer on the inner race of the joint.



15. Use a soft-faced hammer to tap the joint onto the drive shaft until it locks into place.
16. Pull on the joint to make sure it is securely locked in place.
17. Remove excess grease from the CV joint's external surfaces and place the excess grease in the boot.
18. Pull the boot over the joint and position the boot lips into the grooves on the joint housing and shaft. Make sure the boot is not dimpled or collapsed.

FINAL DRIVE

19. Install and tighten the large clamp using the Axle Boot Clamp Tool (PU-48951).



**Axle Boot Clamp Tool
PU-48951**

20. While pulling out on the CV shaft, fully extend the CV joint and slide a straight O-ring pick or a small slotted screw driver between the small end of the boot and the shaft. This will allow the air pressure to equalize in the CV boot in the position that the joint will spend most of its life. Before you remove your instrument, be sure the small end of the boot is in its correct location on the shaft.

21. Install and tighten the small clamp on the boot using the Axle Boot Clamp Tool (PU-48951).



**Axle Boot Clamp Tool
PU-48951**

Inner Plunging Joint / Boot Replacement

1. Using a side cutters, cut away and discard the boot clamps.



2. Remove the large end of the boot from the plunging joint and slide the boot down the shaft.

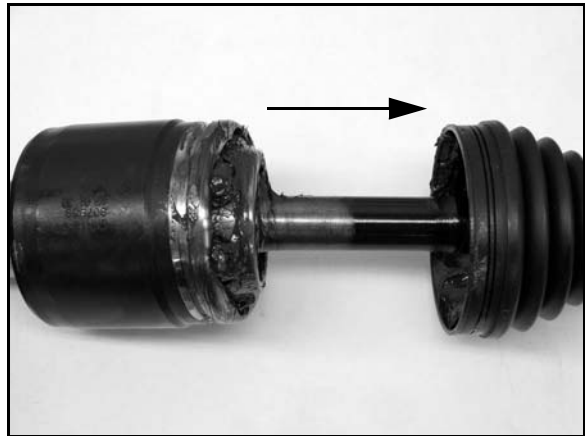

3. Clean the grease from the face of the joint.
4. Place the drive shaft in a soft-jawed vise.
5. Using a soft-faced hammer, or brass drift, strike the inner race of the joint to drive the joint off the drive shaft. Be sure to tap evenly around the joint to avoid binding.

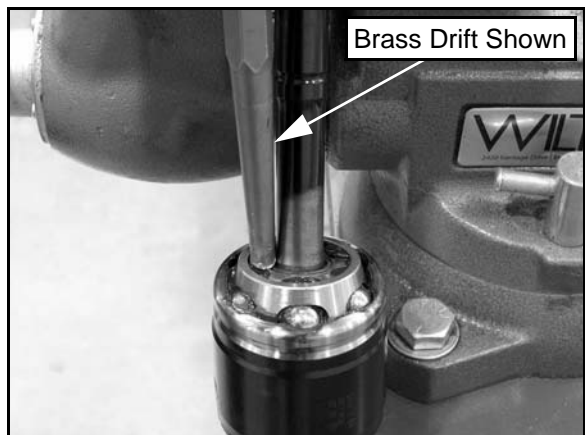

IMPORTANT: Tap on inner race only!

6. Make sure the circlip is still on the shaft and not left in the joint.

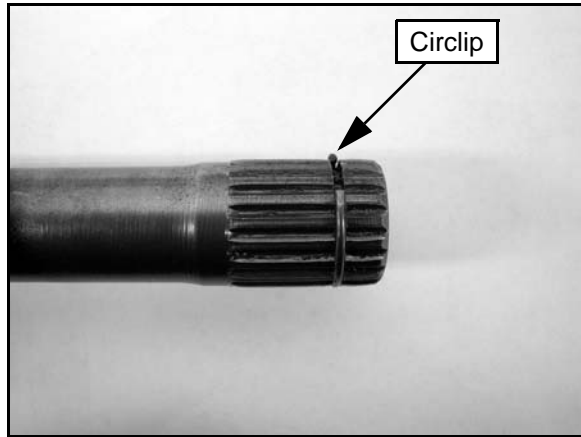

7. Remove the boot from the shaft.

! CAUTION

Complete disassembly of the plunging joint is NOT recommended. The internal components are a precision fit and develop their own characteristic wear patterns. Intermixing the internal components could result in looseness, binding, and/or premature failure of the joint.

IMPORTANT: If the grease in the joint is obviously contaminated with water and/or dirt, the joint should be replaced.

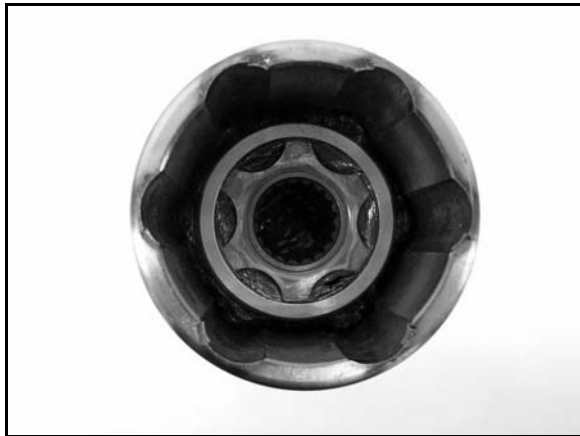

8. Thoroughly clean the joint with an appropriate solvent and dry the joint to prevent any residual solvent from being left in the joint upon reassembly.
9. Visually inspect the joint for damage. Replace if needed.
10. Clean the splines on the end of the shaft and apply a light coat of grease prior to reassembly.

11. Slide the small boot clamp and boot (small end first) onto the drive shaft and position the boot in its groove machined in the shaft.
12. Install a NEW circlip on the end of the shaft.
13. Grease the joint with the special CV joint grease provided in the boot replacement kit. Fill the cavity behind the balls and the splined hole in the joint's inner race. Pack the ball tracks and outer face flush with grease. Place any remaining grease into the boot.

! CAUTION

The grease provided in the replacement kit is specially formulated for wear resistance and durability. DO NOT use substitutes or mix with other lubricants.

NOTE: The amount of grease that's provided is pre-measured, so use all the grease.

Boot Replacement Grease Requirements:

Grease Only Service Kits

PN 1350059 - 20g / PN 1350046 - 30g / PN 1350047 - 50g

Inner Plunging Joint Capacity:

Front - 60g / Rear - 90g

14. Fully compress the joint and push the drive shaft firmly into the inner race.
15. Align the circlip with the lead-in chamfer.



16. Use a soft-faced hammer to tap the joint onto the drive shaft until you reach the end of the splines and the joint locks in place.

FINAL DRIVE

17. Pull on the joint to test that the circlip is seated and that the joint is securely fastened to the shaft.
18. Remove excess grease from the plunging joint's external surfaces and place the excess grease in the boot.
19. Pull the boot over the joint and position the boot lips into the grooves on the joint housing and shaft. Make sure the boot is not dimpled or collapsed.
20. Install and tighten the small clamp using the Axle Boot Clamp Tool (PU-48951).



**Axle Boot Clamp Tool
PU-48951**

21. Pull out on the drive shaft to center the joint in the housing. Slide a straight O-ring pick or a small slotted screw driver between the large end of the boot and the joint housing and lift up to equalize the air pressure in the boot.
22. Position the boot lip in its groove. Install and tighten the large clamp using the Axle Boot Clamp Tool (PU-48951).



**Axle Boot Clamp Tool
PU-48951**

Drive Shaft Exploded View

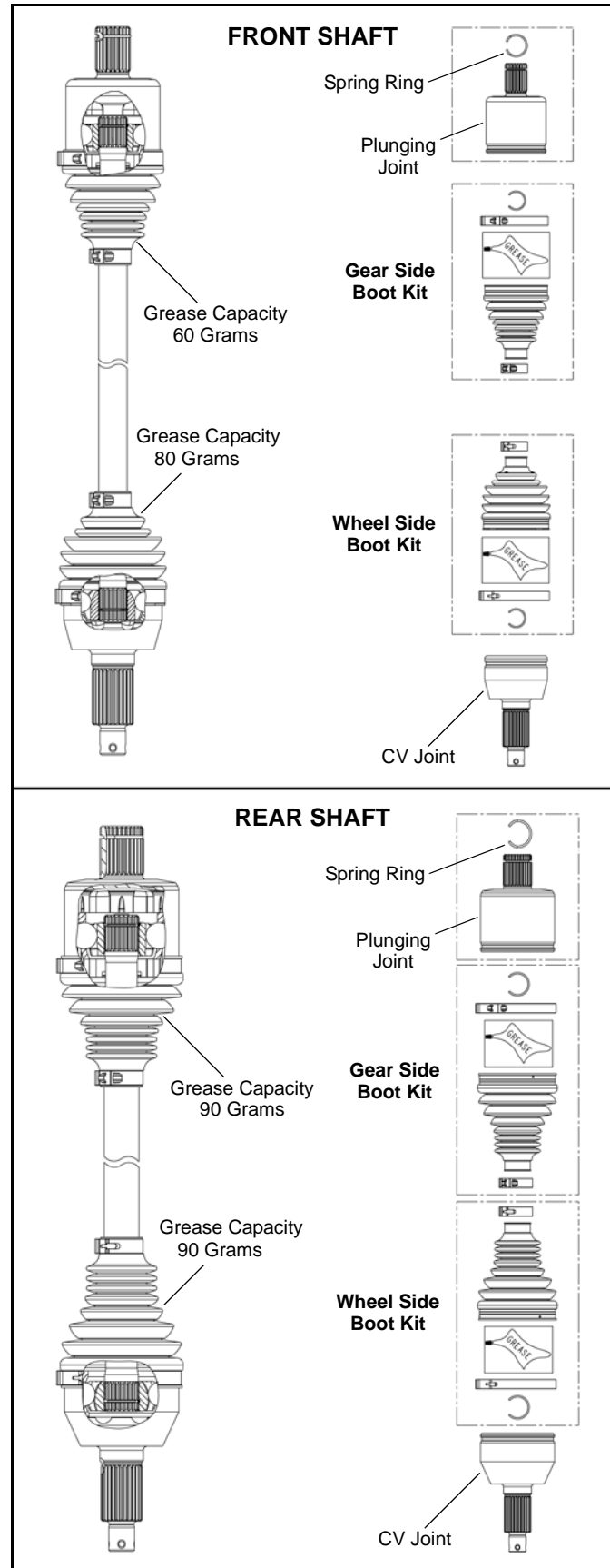

REAR PROPSHAFT

Removal

1. Locate the rear propshaft through the right rear wheel well.

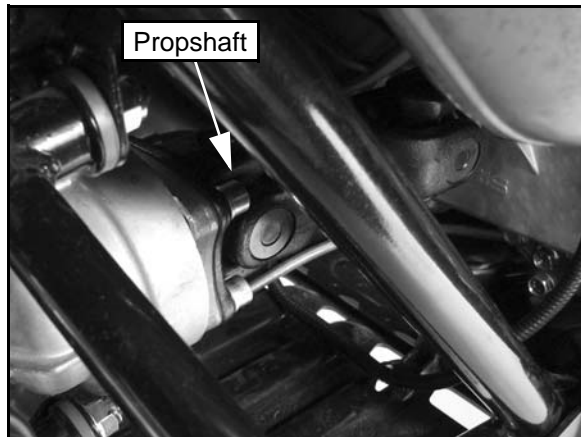

NOTE: If needed, remove the right rear wheel to gain better access to the rear propshaft bolts.

2. Remove the (4) bolts retaining the rear propshaft to the rear gearcase input shaft coupler.



3. Slide the shaft towards the transmission and pivot the propshaft down. Slide the propshaft off the transmission output shaft and out from the vehicle.

Installation

1. Apply anti-seize compound to all splines. Slide propshaft back onto the transmission output shaft, and then lift it up and align it with the rear gearcase input shaft coupler.
2. Install the (4) bolts and torque to specification.



Rear Propshaft Bolts:
18 ft. lbs. (24 Nm)

FINAL DRIVE

REAR GEARCASE

Gearcase Removal

1. Position the vehicle on a level surface and remove the seat.
2. Drain the rear gearcase lubricant (see Chapter 2).
3. Remove the rear cab (see Chapter 9).
4. Remove the left rear wheel, lower left-hand frame support and outer PVT cover (see Chapter 7 "DRIVE BELT - Belt Removal").
5. Remove the (4) bolts retaining the rear propshaft to the rear gearcase input shaft.



6. Slide the shaft towards the transmission and pivot the propshaft down. Slide the propshaft off the transmission output shaft and out from the vehicle.
7. Remove the PVT outlet duct, driven clutch, drive clutch and inner PVT cover (see Chapter 7 "PVT SYSTEM SERVICE - Disassembly").
8. Remove the top retaining nut from each stabilizer bar linkage and rotate the stabilizer bar back out of the way.

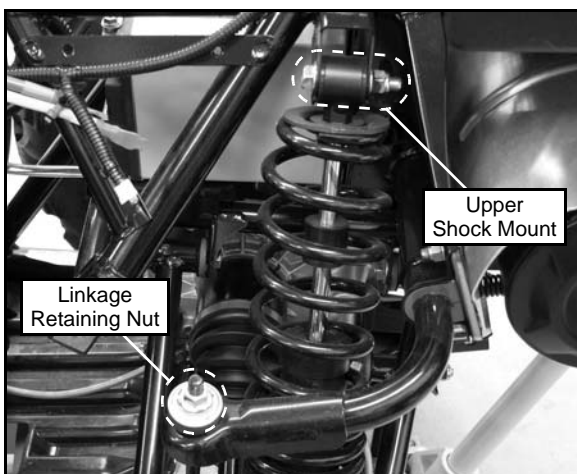

9. Remove the upper shock mounts from each side.
10. Remove the brake line retainer and left rear brake caliper.



CAUTION

Do not hang the brake caliper by the brake line. Use mechanics wire to hang the caliper to prevent from damaging the brake line.

11. Remove the (4) through-bolt fasteners retaining the left rear upper and lower A-arms to the frame.



12. Remove the left rear suspension and drive shaft from the vehicle as an assembly.

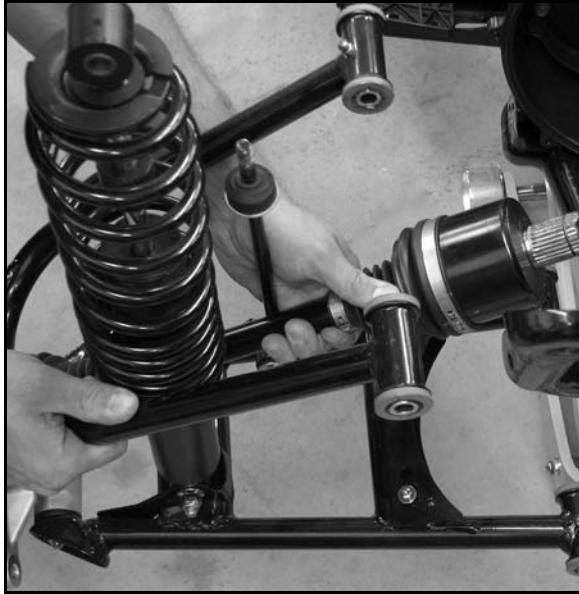

13. Remove the right rear wheel. Remove the cotter pin, nut and washers retaining the drive shaft at the wheel hub.

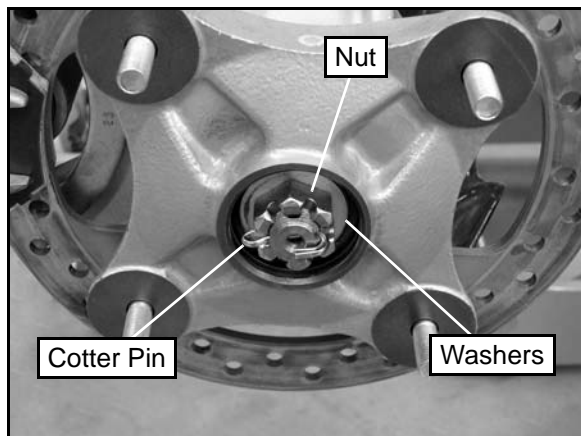

14. Remove the through-bolt fastener retaining the upper A-arm to the bearing carrier. Pivot the wheel hub and bearing carrier down to remove the drive shaft.



IMPORTANT: Take care not to stretch the brake line while removing the drive shaft.

15. Remove the drive shaft from the rear gearcase by pulling sharply.
16. Remove the (4) through-bolts retaining the rear gearcase to the frame.
17. Remove the vent line from the rear gearcase.

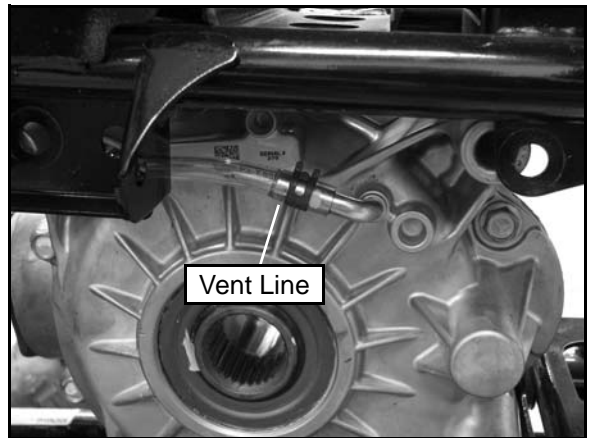

18. Pull the rear gearcase out between the transmission and the frame.

FINAL DRIVE

Gearcase Disassembly and Inspection

IMPORTANT: Pinion and ring gear shimming information is NOT provided. The components are matched at the factory which requires special OEM tooling in order to properly assemble and shim the gears.

In the event damage to the gears or housing requires replacement, the entire assembly must be replaced.

1. Drain and properly dispose of used gearcase lubricant.
2. Remove the (8) screws from the rear gearcase cover.

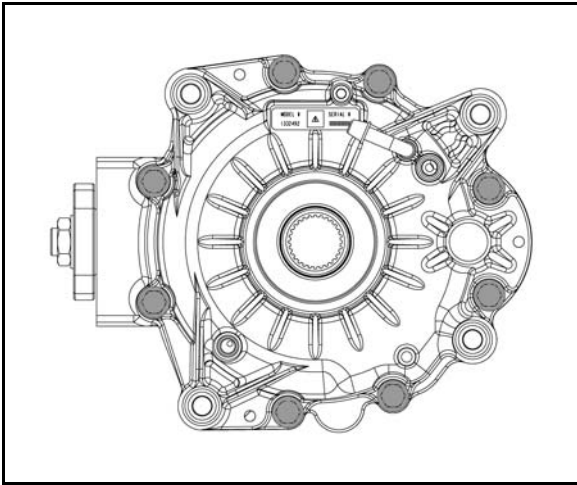

3. Lift the gearcase cover off the main gearcase half and note the shim between the cover and the ring gear.
4. Remove the ring gear from the main gearcase half.

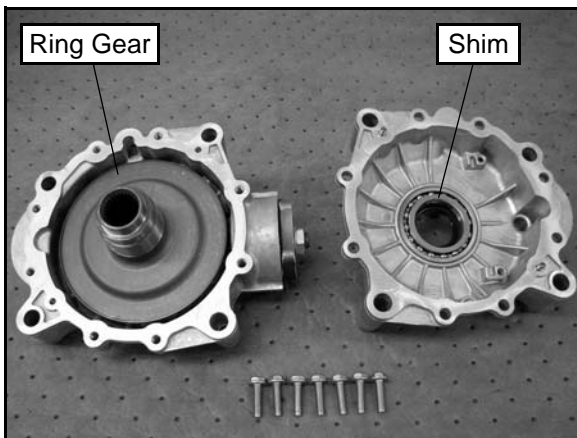

5. Inspect the ring gear teeth for chipped, worn, or broken teeth.

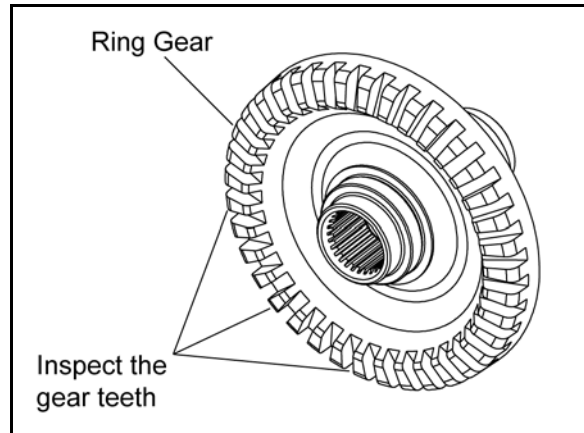

6. Inspect the pinion shaft by rotating the assembly in the gearcase housing while checking for any looseness or roughness. Inspect the pinion gear teeth for chipped, worn, or broken teeth.

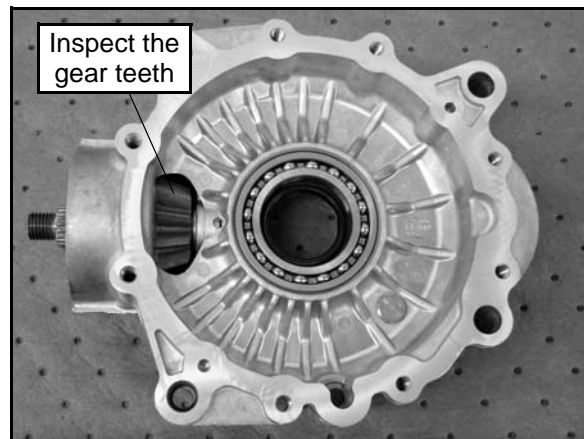

NOTE: In the event damage to the gears or housing requires replacement, the entire assembly must be replaced.

7. Inspect the gearcase bearings and seals. Proceed to "Gearcase Bearing and Seal Replacement" if components require service.

Gearcase Bearing and Seal Replacement

1. If the gearcase is completely assembled, perform the "Gearcase Disassembly and Inspection" procedure.
2. Remove the nut and locking washer(s) from the pinion shaft (nut was loosened during "Gearcase Removal").

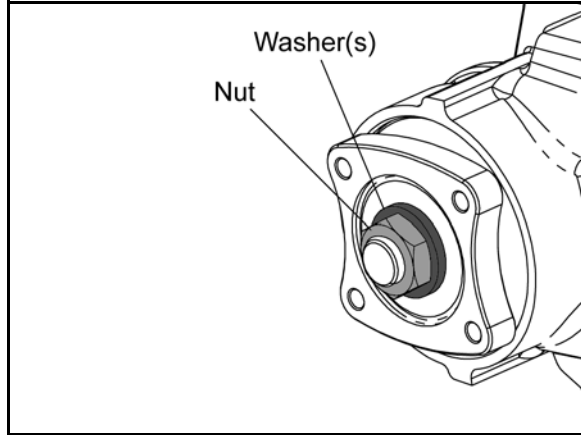

3. Using a universal bolt-grip puller kit, remove the coupler from the pinion shaft.

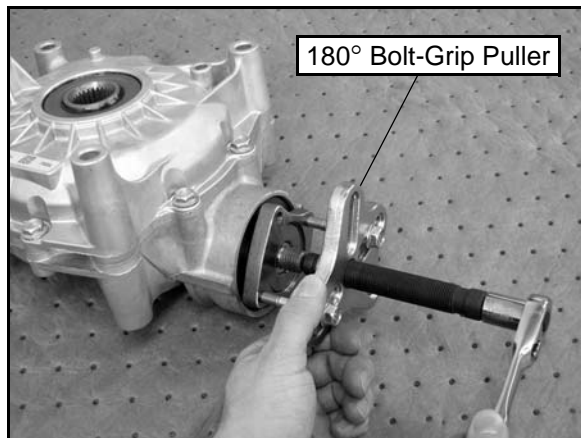

4. Remove the seal above the pinion shaft using a seal puller or other suitable method (see Figure 8-27).

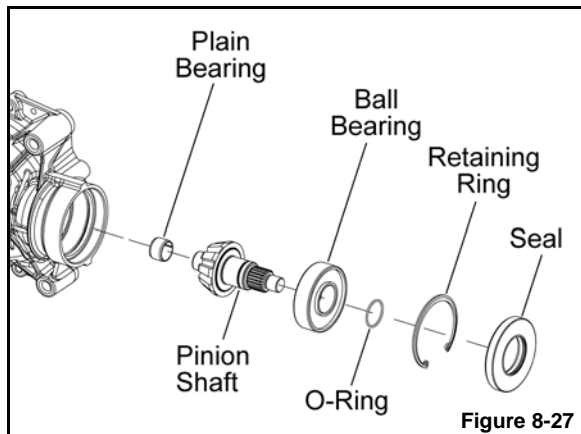

5. Remove the retaining ring and lift the pinion shaft and bearing from the main gearcase (see Figure 8-27).
6. Support the pinion shaft and press the bearing off the shaft (see Figure 8-27).
7. Thoroughly clean the pinion shaft.
8. Support the pinion shaft and carefully press the new bearing on the shaft and install a NEW O-ring (see Figure 8-27).

⚠ WARNING

Wear appropriate safety equipment while installing bearings to reduce the risk of injury.

9. Remove the seals from each case half using a seal puller or other suitable method (see Figure 8-28).

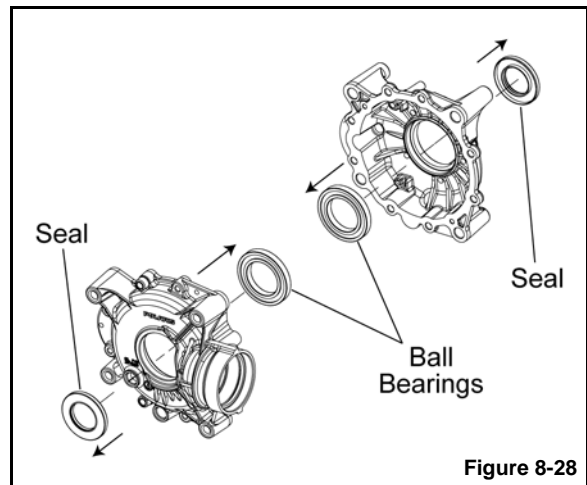

Figure 8-28

10. Support the gearcase cover and press the bearing out. Repeat this procedure on the main gearcase half (see Figure 8-28).
11. Thoroughly clean the gearcase halves.
12. Support the gearcase cover and carefully press in the new bearing. Repeat this procedure on the main gearcase half (see Figure 8-28).

⚠ WARNING

Wear appropriate safety equipment while installing bearings to reduce the risk of injury.

FINAL DRIVE

13. Install the seals into the case halves using a standard seal installer or other suitable method. Seal depth should be approximately .110 in. (2.79 mm) from the main surface.

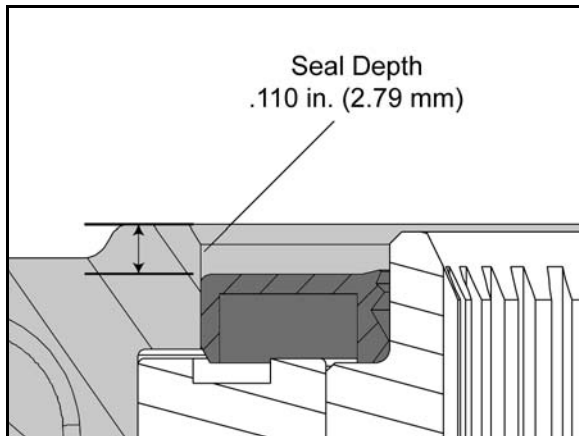

14. Install the pinion shaft into the main gearcase and secure with a NEW retaining ring.
15. Install the seal into the main gearcase half using a standard seal installer or other suitable method. Press seal into the gearcase until it bottoms out in the housing.

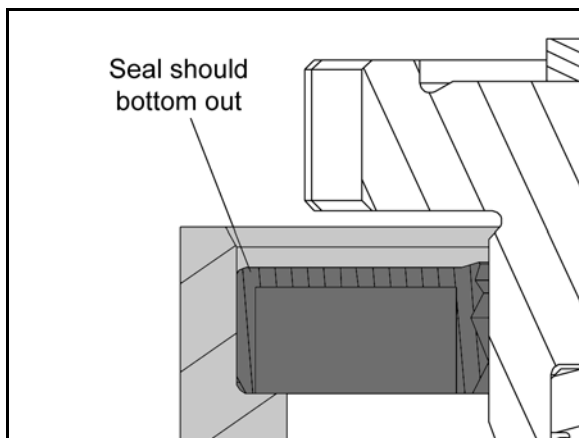

Gearcase Assembly

1. Grease all seals with **Polaris All Season Grease (PN 2871322)** upon assembly to prevent from damaging seals.
2. Install the ring gear into the main gearcase.
3. Install the shim previously removed onto the ring gear.

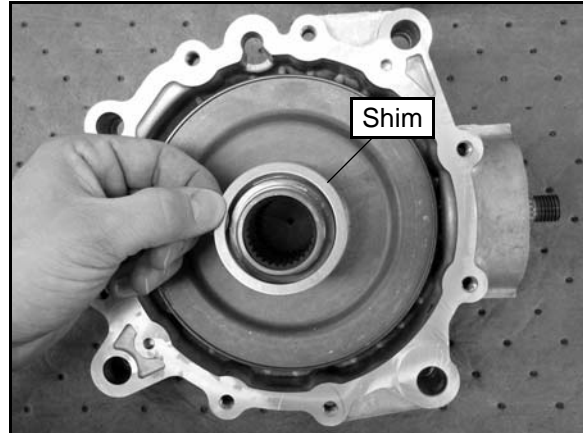

4. Thoroughly clean the gearcase mating surfaces and be sure the alignment pins are in place.
5. Apply Crankcase Sealant (PN 2871557) to mating surfaces.
6. Install the gearcase cover onto the main gearcase half.
7. Install the cover screws and torque to specification.

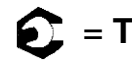
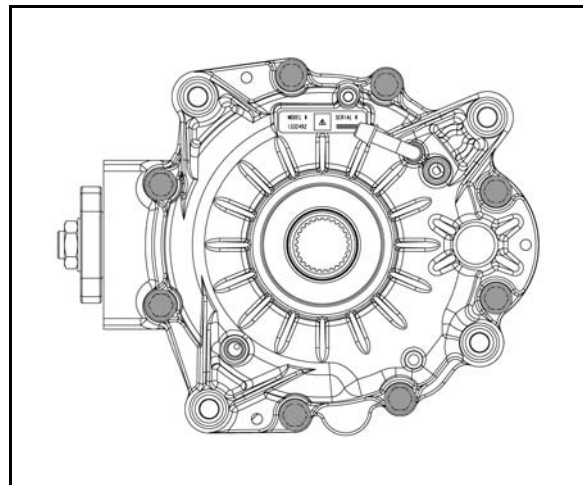

**Cover Screw Torque:
15-20 ft. lbs. (20-27 Nm)**

8. Proceed to "Gearcase Installation" before installing the coupler, locking washer(s), and retaining nut. Doing so will allow you to properly torque the coupler retaining nut.

Gearcase Installation

1. Install the coupler onto the pinion shaft splines.
2. Install the locking washer(s) and retaining nut.
3. Torque the retaining nut to specification.

 = T
Coupler Retaining Nut Torque: 90-110 ft. lbs. (122-149 Nm)

4. Install the rear gearcase by reversing the “Gearcase Removal” procedure at the beginning of this section. Refer to the following steps for torque specifications.
5. Install the gearcase through-bolt mounting fasteners and torque to specification.

NOTE: Use the longer bolts (150 mm) in the top and the shorter bolts (125 mm) in the bottom.

 = T
Gearcase Mounting Fasteners: 40 ft. lbs. (54 Nm)

6. Install the right rear drive shaft and the upper A-arm onto the bearing carrier. Torque through-bolt fastener to specification.

 = T
Rear Upper A-arm to Bearing Carrier: 40 ft. lbs. (54 Nm)

7. Install the cone washers (dome facing retaining nut) and right rear hub retaining nut. Torque to specification and install a new cotter pin.

 = T
Rear Hub Retaining Nut: 80 ft. lbs. (108 Nm)

8. Install the left rear drive shaft and suspension assembly. Torque the upper and lower A-arms to specification.

 = T
Rear Upper & Lower A-arms to Frame: 45 ft. lbs. (61 Nm)

9. Install the left rear brake caliper and brake line retainer. Torque brake caliper mounting bolts to specification.

 = T
Brake Caliper Mounting Bolts: 37 ft. lbs. (50 Nm)

10. Install the rear upper shock through-bolts. Torque bolts to specification.

 = T
Rear Upper Shock Bolts: 37 ft. lbs. (50 Nm)

11. Install the rear stabilizer bar onto the linkage rods. Torque the linkage retaining nuts to specification.

 = T
Stabilizer Bar Linkage Retaining Nuts: 17 ft. lbs. (23 Nm)



12. Install the rear propshaft and torque bolts to specification.

 = T
Rear Propshaft Bolts: 18 ft. lbs. (24 Nm)

13. Reassemble the PVT system (see Chapter 7 “PVT SYSTEM SERVICE - Assembly”).

14. Install the rear wheels and torque wheel nuts to specification (see Page 8.2).

15. Add Polaris ATV Angle Drive Fluid to rear gearcase (see Chapter 2). Torque drain and fill plugs to specification.

 = 
Rear Gearcase Capacity: 7.1 fl. oz. (210 ml) or to bottom of fill plug hole threads See Chapter 2 “Maintenance”

 = T
Drain / Fill Plug: 10-14 ft. lbs. (14-19 Nm)

FINAL DRIVE

Gearcase Exploded View

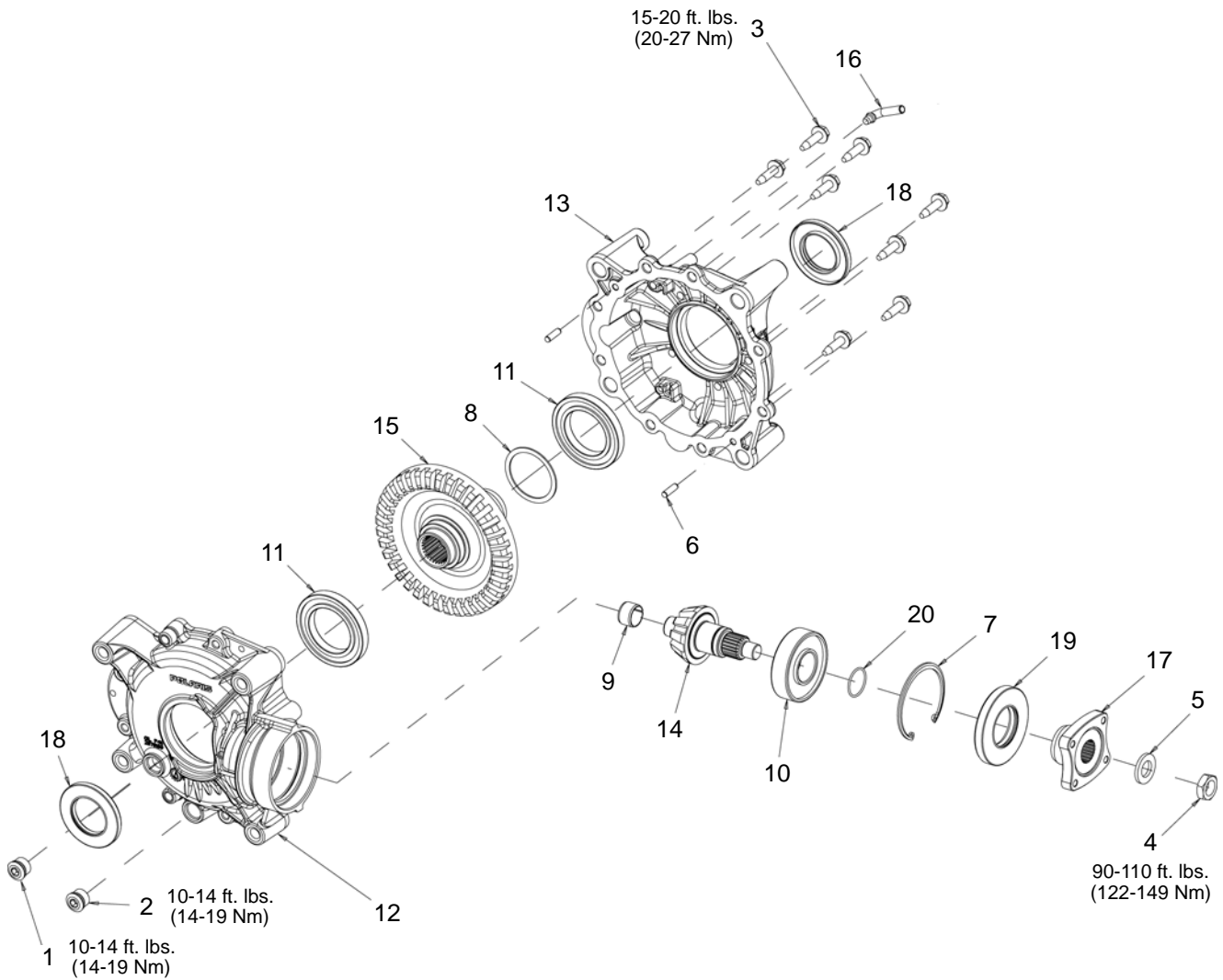

REF#	DESCRIPTION	QTY	REF#	DESCRIPTION	QTY
1	Fill Plug with O-ring	1	11	Ball Bearing	2
2	Drain Plug with O-ring, Magnetic	1	12	Main Case, Machined	1
3	Screw	8	13	Cover, Machined	1
4	Nut	1	14	Pinion Shaft, 10T Straight Bevel	1
5	Locking Washer	1	15	Ring Gear, 37T Straight Bevel	1
6	Dowel Pin	2	16	Vent Tube	1
7	Retaining Ring	1	17	Coupler	1
8	Shim	1	18	Triple Lip Seal	2
9	Plain Bearing	1	19	Triple Lip Seal	1
10	Ball Bearing	1	20	O-Ring	1

CHAPTER 9

BODY / FRAME

TORQUE SPECIFICATIONS	9.2
DECAL REPLACEMENT	9.2
SPECIAL TOOLS	9.2
PLASTIC PUSH RIVET REMOVAL	9.2
MULTI-FUNCTION PLIERS	9.2
SEAT AND SIDE PANELS	9.3
REMOVAL / INSTALLATION	9.3
FRONT RACK	9.3
REMOVAL / INSTALLATION	9.3
FRONT BUMPER	9.4
REMOVAL / INSTALLATION	9.4
MUD GUARDS	9.4
REMOVAL / INSTALLATION	9.4
FOOTWELLS	9.4
REMOVAL / INSTALLATION	9.4
FRONT CAB	9.5
REMOVAL	9.5
INSTALLATION	9.5
REAR RACK	9.6
REMOVAL / INSTALLATION	9.6
REAR BUMPER COVERS	9.6
REMOVAL / INSTALLATION	9.6
REAR CAB	9.6
REMOVAL / INSTALLATION	9.6
HEADLIGHT POD	9.7
DISASSEMBLY / REMOVAL	9.7
ASSEMBLY / INSTALLATION	9.7
MAIN FRAME	9.8
FRAME SUPPORT EXPLODED VIEW	9.8
CHASSIS	9.9
BODY PLASTIC REMOVED VIEW	9.9

BODY / FRAME**TORQUE SPECIFICATIONS**

ITEM	TORQUE VALUE ft.lbs. (Nm)
Upper RH Frame Support	30 ft. lbs. (41 Nm)
Lower LH Frame Support	30 ft. lbs. (41 Nm)

DECAL REPLACEMENT**⚠ WARNING**

The following procedure involves the use of an open flame. Perform this procedure in a well ventilated area, away from gasoline or other flammable materials. Be sure the area to be flame treated is clean and free of gasoline or flammable residue.

⚠ WARNING

Do not flame treat components that are installed on the vehicle. Remove the component from the vehicle before flame treating.

The side panels, front and rear fender cabs are plastic polyethylene material. Therefore, they must be “flame treated” prior to installing a decal to ensure good adhesion. A bonus of the flame treating procedure is it can be used to reduce or eliminate the whitish stress marks that are sometimes left after a fender or cab is bent, flexed, or damaged.

To flame treat the decal area:

1. Pass the flame of a propane torch back and forth quickly over the area where the decal is to be applied until the surface appears slightly glossy. This should occur after just a few seconds of flame treating. Do not hold the torch too close to the surface (2-3 inches from the flame tip is recommended). Keep the torch moving to prevent damage.
2. Apply the decal on one edge first. Slowly lay down remainder of the decal while rubbing lightly over the decal surface to eliminate any air bubbles during the application.

SPECIAL TOOLS**Plastic Push Rivet Removal**

Polaris ATVs use a two piece plastic push rivet to fasten most body components. Using the “Multi-Function Pliers” eases removal and prevents from damaging the push rivets and body components.

Multi-Function Pliers

Included in the tool kit, the multi-function pliers is designed to remove the plastic push rivets used to fasten body components.

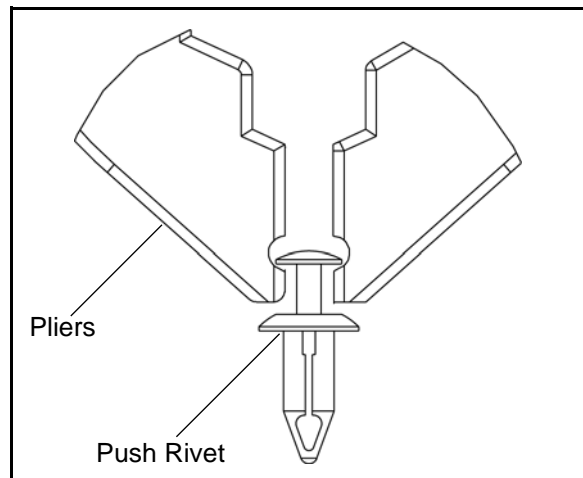
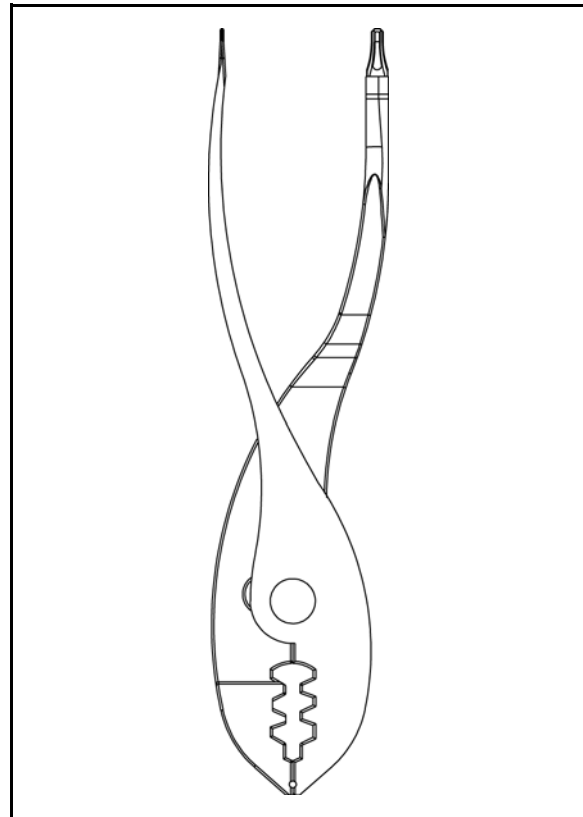

SEAT AND SIDE PANELS**Removal / Installation**

1. Grasp one side of the seat near the rear edge.
2. Pull upward abruptly to disengage the under-seat fasteners.

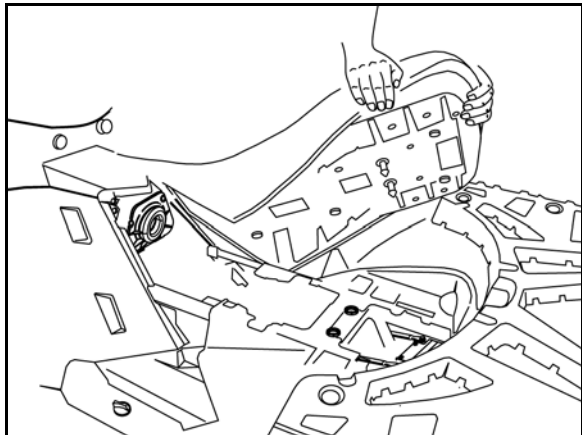

3. Remove the seat.
4. Remove the screws and push rivets securing the side panels on each side (see illustration).

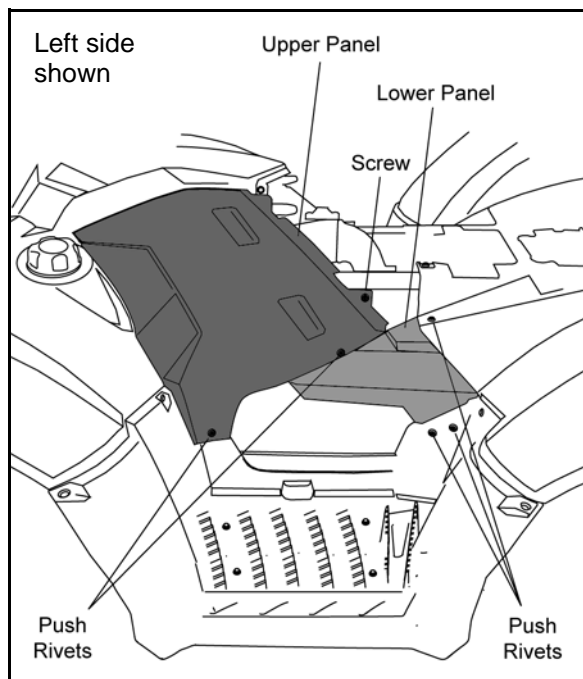

5. If removing the right-hand side panel, remove the gear shift selector cap, retaining screw and knob to allow removal.

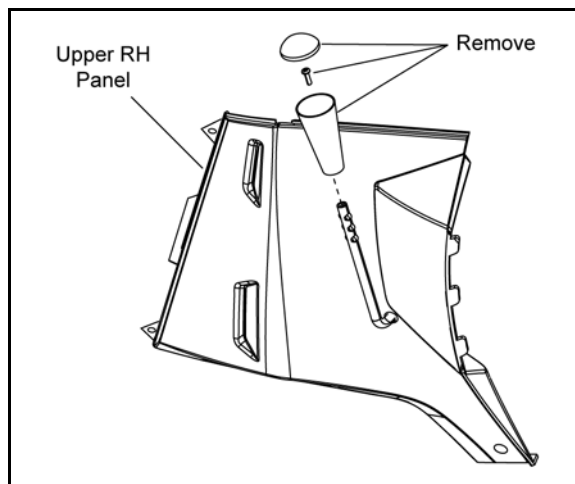

6. Reverse this procedure to reinstall components.
7. When installing the seat, start the front portion first, then follow by installing the rear portion. Be sure the under-seat fasteners are fully engaged upon installation.

FRONT RACK**Removal / Installation**

1. Release the front rack latches and remove the rack as an assembly.



2. To reinstall the rack, hold the rack as shown in the previous photo. Position the front edge in the tabs, then push the rack downward and secure the latches.

BODY / FRAME

FRONT BUMPER

Removal / Installation

1. Remove the (2) push rivets from each side of the bumper.

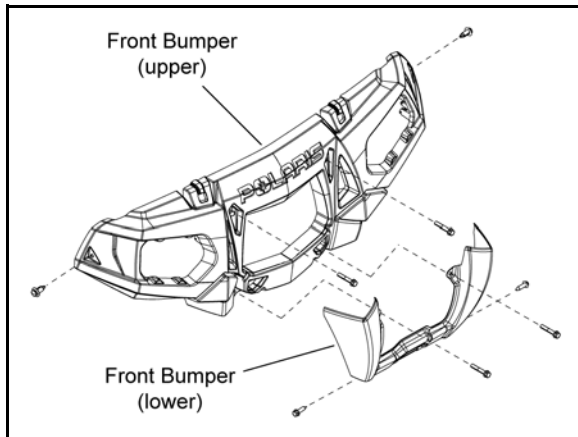

2. Remove the (4) bolts retaining the upper front bumper to the frame.
3. Remove the bulbs from the head lights by turning the bulbs 90° counterclockwise and remove the upper front bumper from the vehicle.
4. If removing the lower front bumper, remove the (2) bolts from each side retaining the bumper to the frame.
5. Reverse this procedure to reinstall the front bumper.

MUD GUARDS

Removal / Installation

1. Locate the mud guards in the front wheel well area.
2. Remove the (4) push rivets from each mud guard and remove from them from the wheel well.

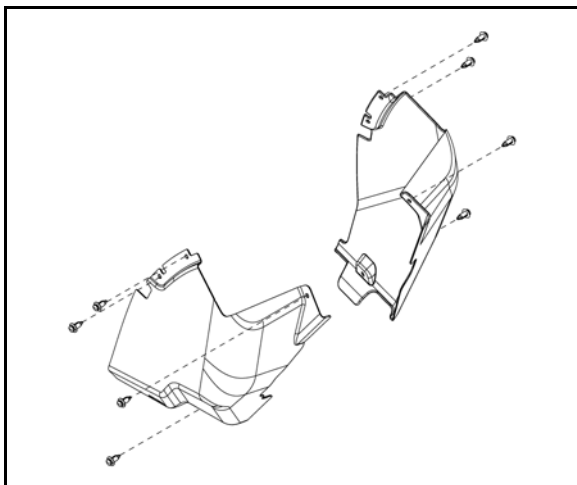

3. Reverse this procedure to reinstall the mud guards.

FOOTWELLS

Removal / Installation

1. Remove the seat and upper side panel (see "SEAT AND SIDE PANELS").
2. Remove the push rivets and screws that retain the footwell.

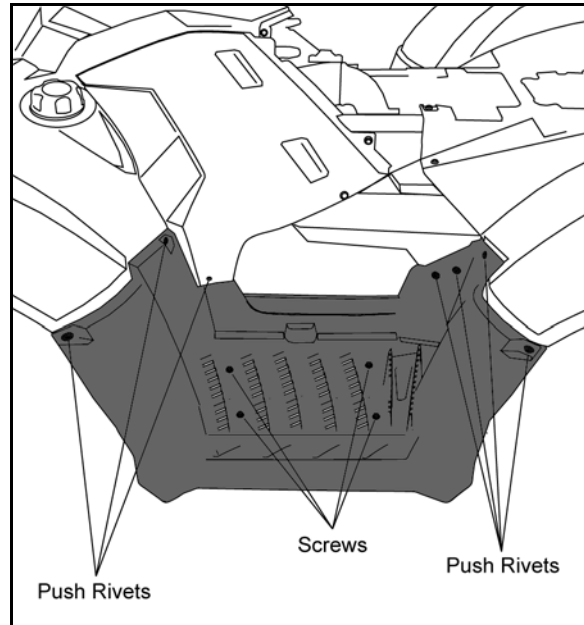

3. Repeat this procedure to remove the other footwell.
4. Reverse this procedure to reinstall the footwells.

NOTE: Be sure to properly align the cab ends into the footwells upon reassembly.

FRONT CAB**Removal**

1. Remove the seat and upper side panels (see “SEAT AND SIDE PANELS”).
2. Remove the mud guards (see “MUD GUARDS”).
3. Remove the (4) push rivets retaining the front cab to the footwells on each side.
4. Remove the (2) screws retaining the front cover to the front cab and remove the cover.

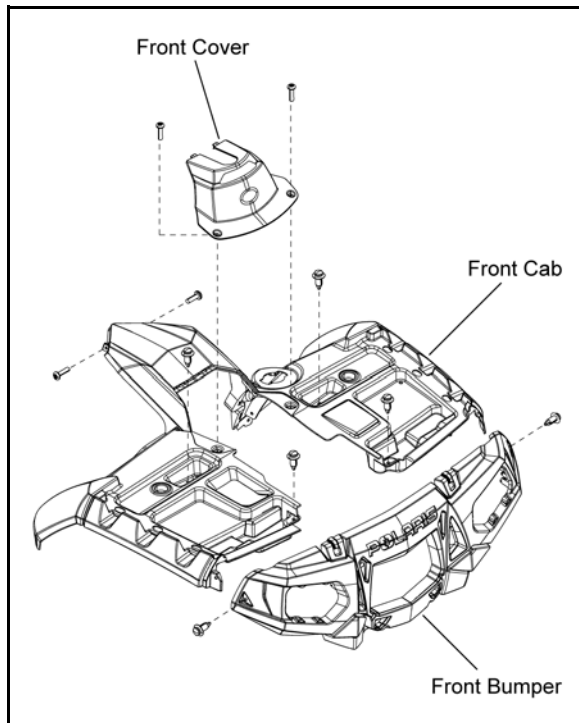

5. Remove the (2) screws retaining the rear portion of the front cab to the airbox.
6. Remove the (4) push rivets retaining the front cab to the frame.
7. Thoroughly clean the area around the fuel tank fill hose located in the left front wheel well.
8. Loosen the upper clamp retaining the fuel fill hose to the front cab.
9. Carefully lift up on the front cab to disengage the fuel fill hose.

10. Using a clean shop rag or towel, cover the fuel fill hose inlet to prevent dirt or debris from entering the fuel tank.

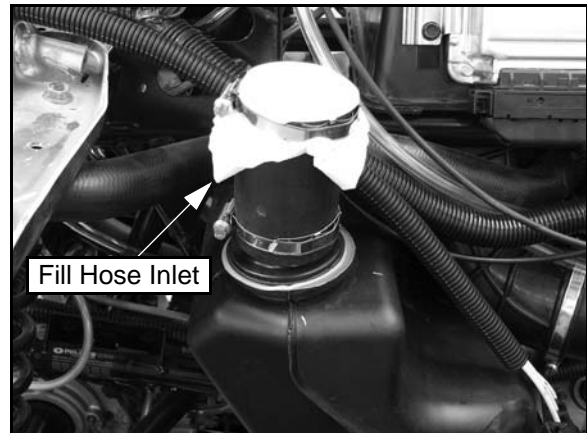

⚠ CAUTION

Failure to cover the fuel fill hose inlet by allowing dirt or debris to enter the fuel tank could lead to premature fuel pump failure. Always take care to not allow anything to enter the fuel tank.

11. Carefully lift up and pull the front cab toward the rear of the ATV to clear in the headlight pod.

Installation

1. Carefully install the front cab onto the frame.
2. Uncover the fuel fill hose inlet and attach the hose to the front cab. Torque the upper hose clamp to specification.

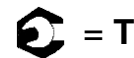

Upper Fuel Fill Hose Clamp:
24 in. lbs. (2.7 Nm)

3. Install the push rivets retaining the front cab to the frame.
4. Install the screws retaining the front cab to the airbox.
5. Install the front cover.
6. Install the push rivets retaining the front cab to the footwells.
7. Install the mud guards, upper side panels and seat.

BODY / FRAME

REAR RACK

Removal / Installation

1. Remove the (8) Torx-headed fasteners as shown below.
2. Remove the rear rack and rack support from the rear cab.

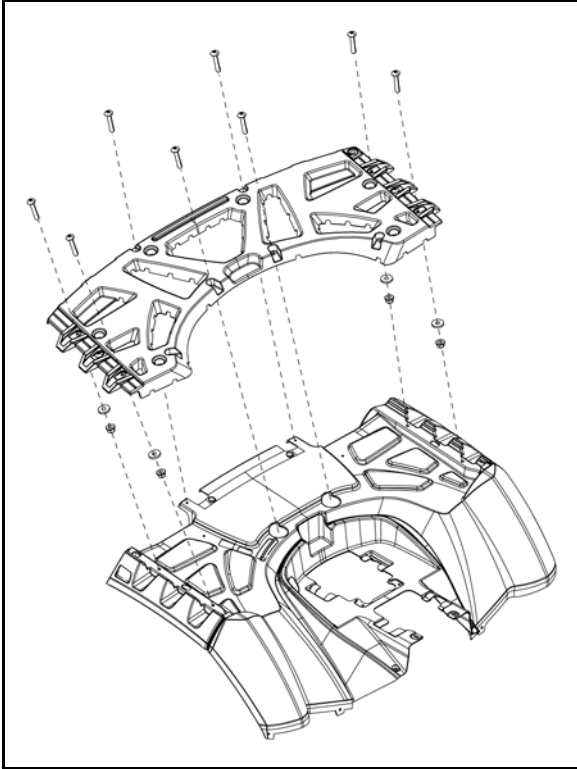

3. Reverse this procedure to reinstall.

REAR BUMPER COVERS

Removal / Installation

1. Open the rear storage compartment and remove the (4) bolts retaining the rear bumper covers.

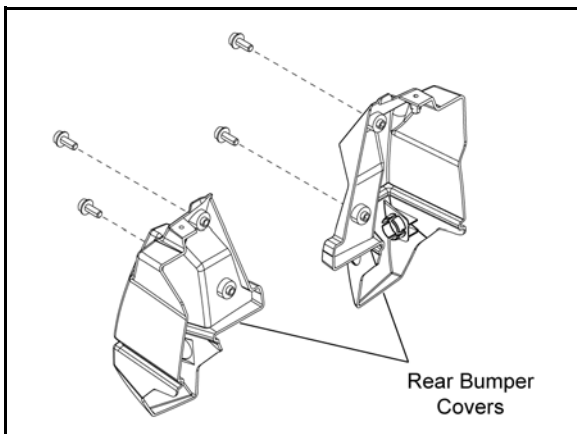

2. Remove the (4) screws retaining the rear cab to the frame (see "REAR CAB").
3. Lift up on the rear cab and remove the bumper covers by sliding them off the rear bumper.
4. Reverse this procedure to reinstall the covers.

REAR CAB

Removal / Installation

1. Remove the (10) push rivets and (4) Torx-headed screws retaining the rear cab assembly.

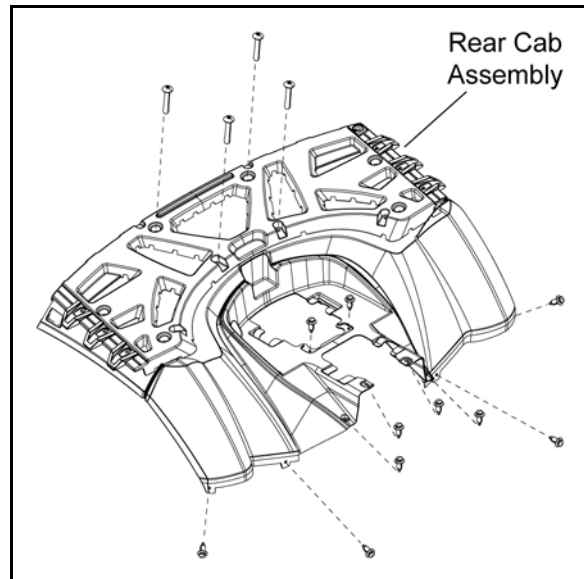

2. Remove the tail light bulbs from the tail lamps, disconnect the tail light harnesses from the rear cab, and remove the rear cab as an assembly.
3. Reverse this procedure to reinstall. Be sure to lock the tail light bulbs in place by turning them 90° clockwise.

HEADLIGHT POD

Disassembly / Removal

1. Remove the (5) Torx-headed screws retaining the upper and lower headlight pods.

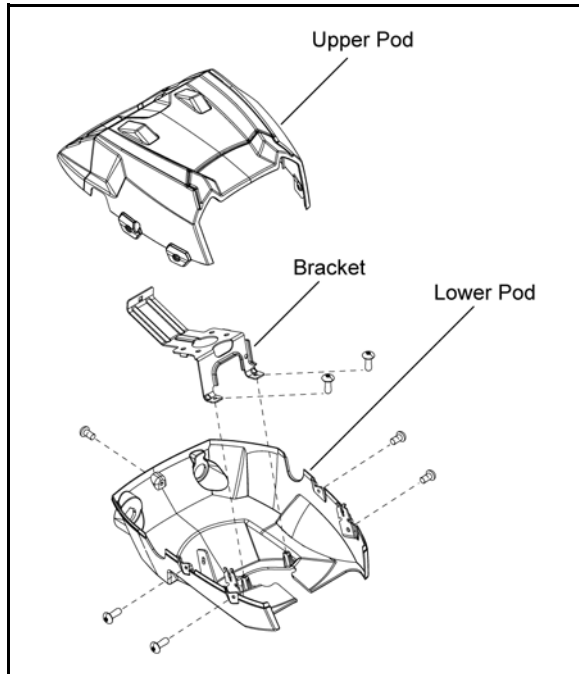

2. If removing the instrument cluster, unplug the two harnesses and push the instrument cluster out from the upper pod.
3. Disconnect and remove the headlight assembly from the lower pod.
4. Remove the (2) Torx-headed screws retaining the lower headlight pod to the mount bracket.
5. Disconnect the key switch and 12V outlet. If replacing the lower pod, remove the key switch and 12V outlet.

IMPORTANT: Take note of all vent line, wire harness and throttle cable routing for reassembly purposes.

6. Remove the lower pod from the vehicle.

Assembly / Installation

1. Reverse the “Disassembly / Removal” procedure.

NOTE: Make sure to route all vent lines, wire harness and throttle cable correctly into the lower headlight pod.

2. When installing the headlight into the lower pod, be sure to install the O-rings prior to installing the headlight.
3. Place the headlight into the lower pod mounting tabs and press firmly until the headlight snaps into place.
4. Lift the O-ring up and over the headlight mounting tab to secure it.

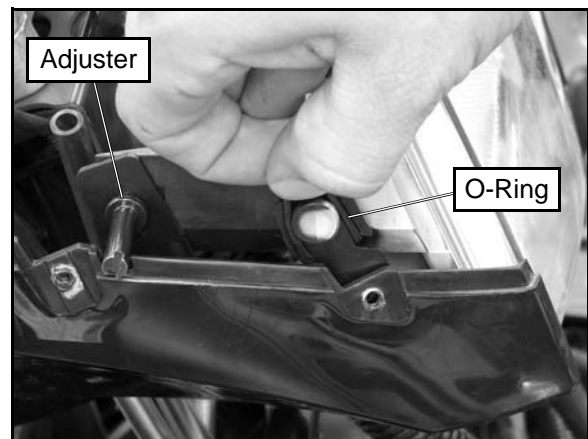

5. Reinstall the adjustment screw.
6. Properly align the upper headlight after reassembly.

BODY / FRAME

MAIN FRAME

Frame Support Exploded View

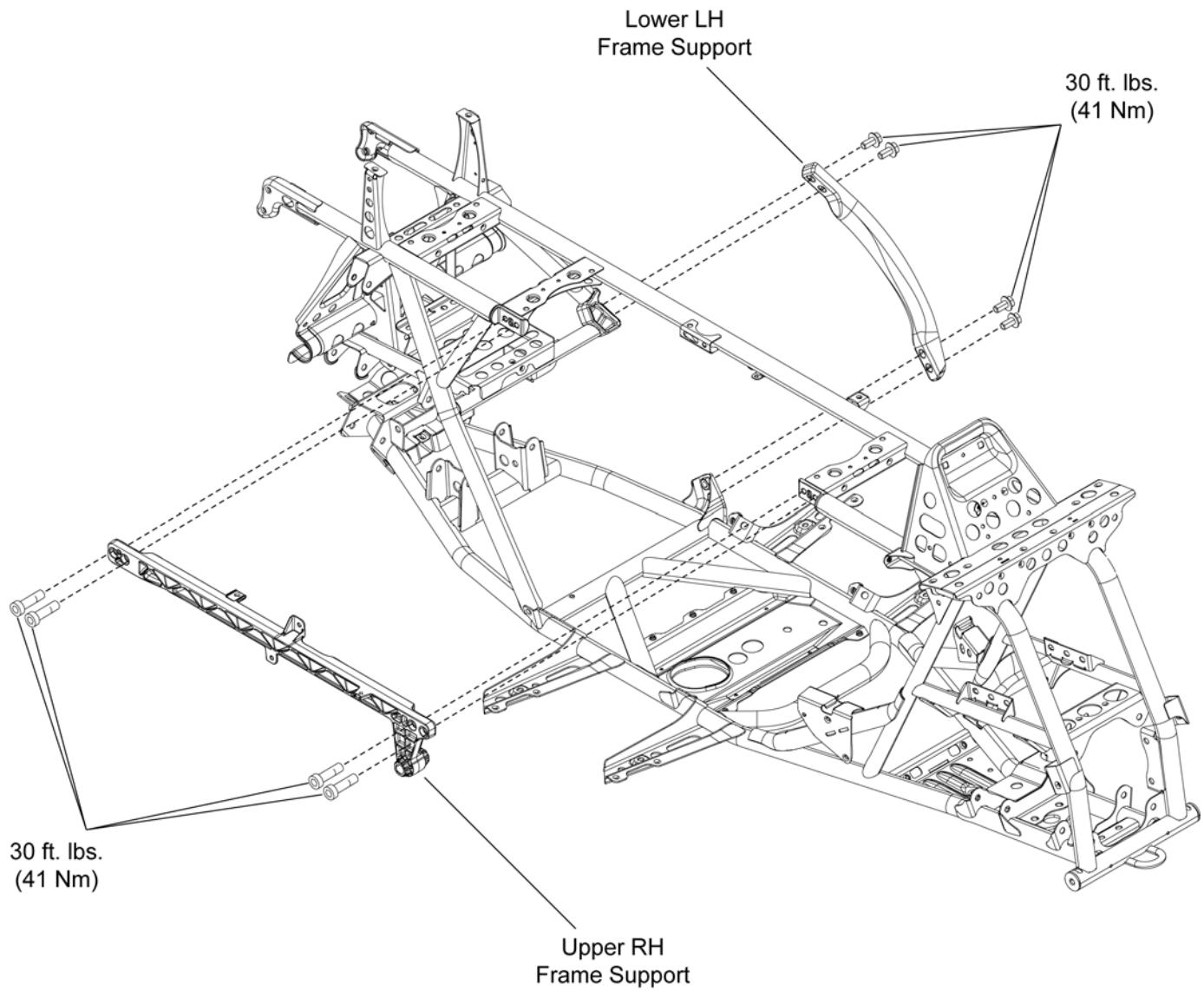

CHASSIS

Body Plastic Removed View



CHAPTER 10

STEERING / SUSPENSION

GENERAL SPECIFICATIONS	10.2
TORQUE SPECIFICATIONS	10.2
HANDLEBAR	10.2
REMOVAL / REPLACEMENT	10.2
INSTALLATION	10.3
STEERING	10.3
STEERING POST REMOVAL	10.3
STEERING POST INSTALLATION	10.4
STEERING EXPLODED VIEW	10.5
STEERING (EPS MODELS)	10.6
UPPER STEERING POST REMOVAL / INSTALLATION	10.6
POWER STEERING UNIT REMOVAL	10.7
POWER STEERING UNIT INSTALLATION	10.8
STEERING EXPLODED VIEW (EPS MODELS)	10.10
STEERING TIE ROD	10.11
TIE ROD / TIE ROD END REPLACEMENT	10.11
FRONT A-ARMS	10.12
EXPLODED VIEW	10.12
REMOVAL / REPLACEMENT	10.13
BALL JOINT SERVICE	10.14
REMOVAL	10.14
INSTALLATION	10.15
REAR A-ARMS	10.16
EXPLODED VIEW	10.16
REMOVAL / INSTALLATION	10.17
REAR STABILIZER BAR	10.18
EXPLODED VIEW	10.18
LINKAGE REMOVAL / INSTALLATION	10.19
STABILIZER BAR REMOVAL / INSTALLATION	10.19
SHOCKS / SPRINGS	10.20
EXPLODED VIEW	10.20
SHOCK REMOVAL / INSTALLATION	10.20
SHOCK / SPRING REPLACEMENT	10.20

STEERING / SUSPENSION

GENERAL SPECIFICATIONS

Torque Specifications

Item	Specification
Aluminum Wheels	75 ft. lbs. (102 Nm)
Steel Wheels	45 ft. lbs. (61 Nm)
Wheel Hub Retaining Nuts (front and rear)	80 ft. lbs. (108 Nm)
Steering Post to Bulkhead	20 ft. lbs. (27 Nm)
Steering Post to Gearcase	22 ft. lbs. (30 Nm)
Tie Rod Jam Nuts	12 ft. lbs. (16 Nm)
Tie Rod to Bearing Carrier Tie Rod to Steering Frog	44 ft. lbs. (60 Nm)
Handlebar Block Bolts	14 ft. lbs. (19 Nm)
Shock Mounting Bolts	37 ft. lbs. (50 Nm)
Front Ball Joint Pinch Bolts (upper and lower)	21 ft. lbs. (28 Nm)
Front A-arm to Frame Bolts (upper and lower)	40 ft. lbs. (54 Nm)
Rear A-arm to Frame Bolts (upper and lower)	45 ft. lbs. (61 Nm)
Rear Upper A-Arm to Bearing Carrier Bolts	40 ft. lbs. (54 Nm)
Rear Lower A-Arm to Bearing Carrier Bolts	45 ft. lbs. (61 Nm)

CAUTION

Locking nuts, and bolts with pre-applied locking agent should be replaced if removed.
The self-locking properties of the nut or bolt are reduced or destroyed during removal

NOTE: Refer to exploded views throughout this chapter for more torque specifications, component identification, and location of components.

HANDLEBAR

Removal / Replacement

1. Remove the upper and lower headlight pods from the handlebar bracket (see Chapter 9).

IMPORTANT: Take note of all vent line, wire harness and throttle cable routing for reassembly purposes.

2. Remove the (4) fasteners retaining the handlebar bracket and block to the steering post.

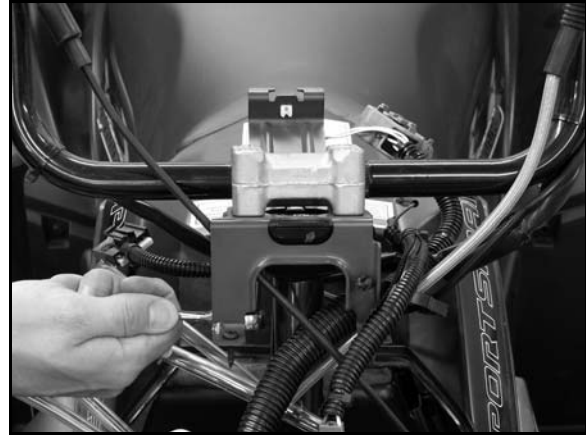

3. Remove the handlebar assembly from the steering post

IMPORTANT: Take care not to bend the throttle cable or brake line while the handlebar is removed.

4. If replacing the handlebar:
 - Remove the RH and LH controls
 - Remove the hand grips
 - Pry open the upper and lower handlebar blocks and remove them from the handlebar

Installation

1. Locate the the alignment pin on the bottom side of the upper block. The pin should line up with the alignment hole in the lower block and should face the front.

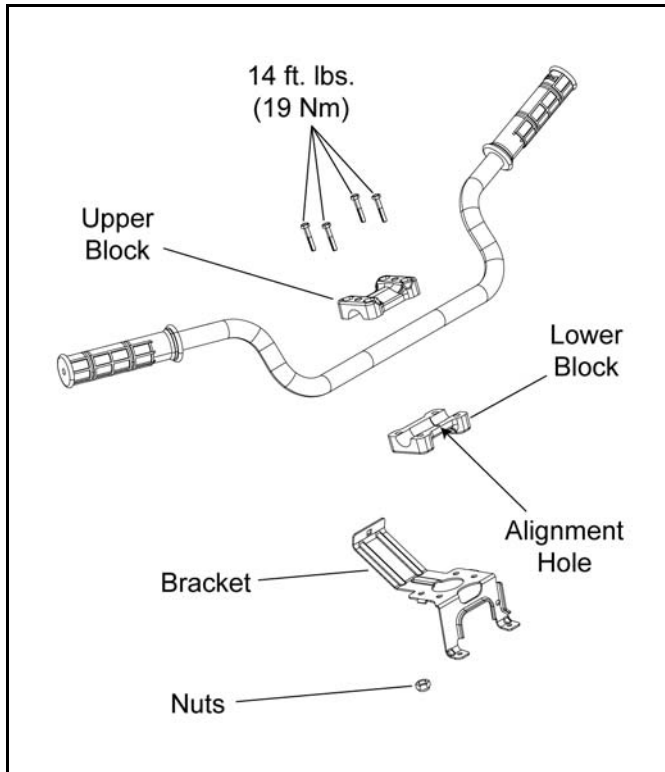

2. Position the handlebar properly and install the (4) bolts.
3. Evenly tighten the pin side (front) bolts first. Torque the (2) front bolts to specification.

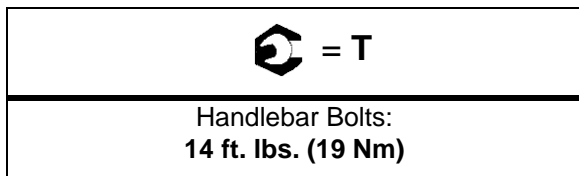

4. Install the rear bolts and tighten evenly. Torque the (2) rear bolts to specification.

NOTE: There will be a slight gap on the backside of the handlebar blocks after installation.

5. If handlebar was replaced:
 - Install the hand grips
 - Install the RH and LH controls

6. Reassemble the headlight pod (see Chapter 9) .

NOTE: Make sure to route all vent lines, wire harness and throttle cable correctly into the lower headlight pod.

STEERING

Steering Post Removal

1. Remove the front rack and front cover (see Chapter 9).
2. Remove the upper and lower headlight pods from the handlebar bracket (see Chapter 9).

IMPORTANT: Take note of all vent line, wire harness and throttle cable routing for reassembly purposes.

3. Remove the (4) fasteners retaining the handlebar bracket and block to the steering post.

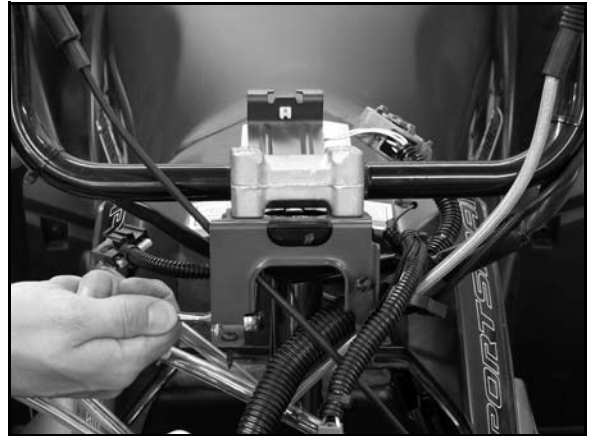

4. Carefully remove the handlebar assembly from the steering post and place it on the front cab.

IMPORTANT: Take care not to bend the throttle cable or brake line while the handlebar is removed.

5. Remove the cotter pin and nut from each tie rod end at the steering post frog.

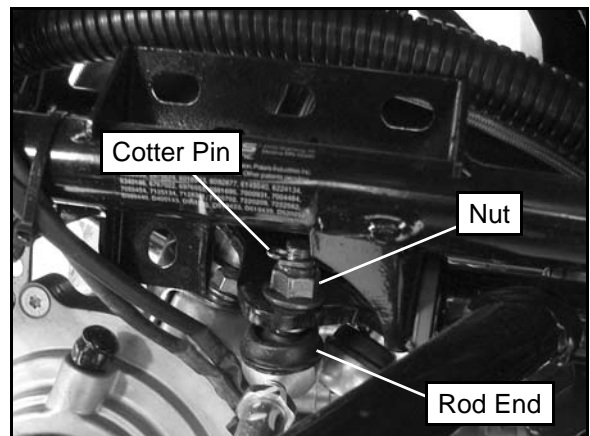

STEERING / SUSPENSION

- Remove the (2) bolts retaining the lower steering post bracket to the front gearcase.

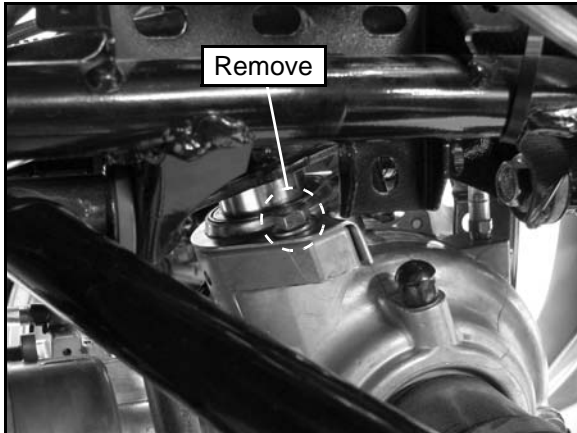

- Remove the (2) fasteners retaining the upper steering post bushing bracket.

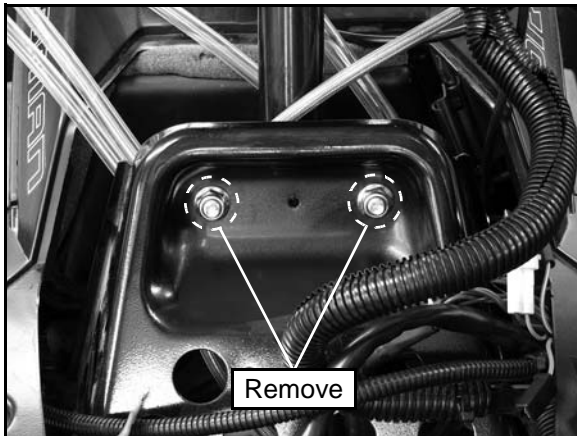

- Lift the steering post assembly up from the front gearcase and carefully remove it from the chassis.

Steering Post Installation

- Reverse the "Steering Post Removal" procedure to reinstall the steering post. Refer to the "Steering Exploded View" for torque values.

NOTE: Make sure to route all vent lines, wire harness and throttle cable correctly into the lower headlight pod.

- When installing the headlight into the lower pod, be sure to install the O-rings prior to installing the headlight.
- Place the headlight into the lower pod mounting tabs and press firmly until the headlight snaps into place.
- Lift the O-ring up and over the headlight mounting tab to secure it.

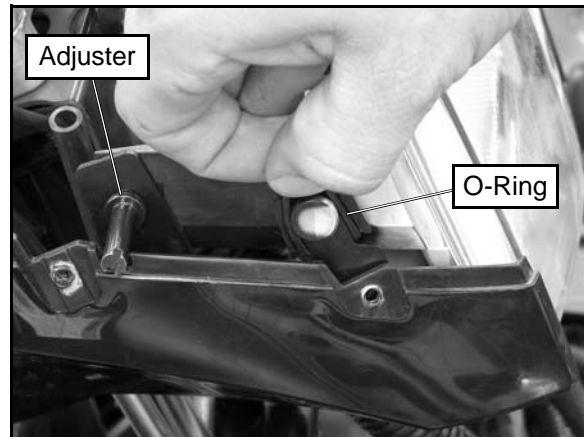

- Reinstall the adjustment screw and be sure to adjust the upper headlight after reassembly.

NOTE: Refer to Chapter 9 when reassembling the upper and lower headlight pods.

Steering Exploded View

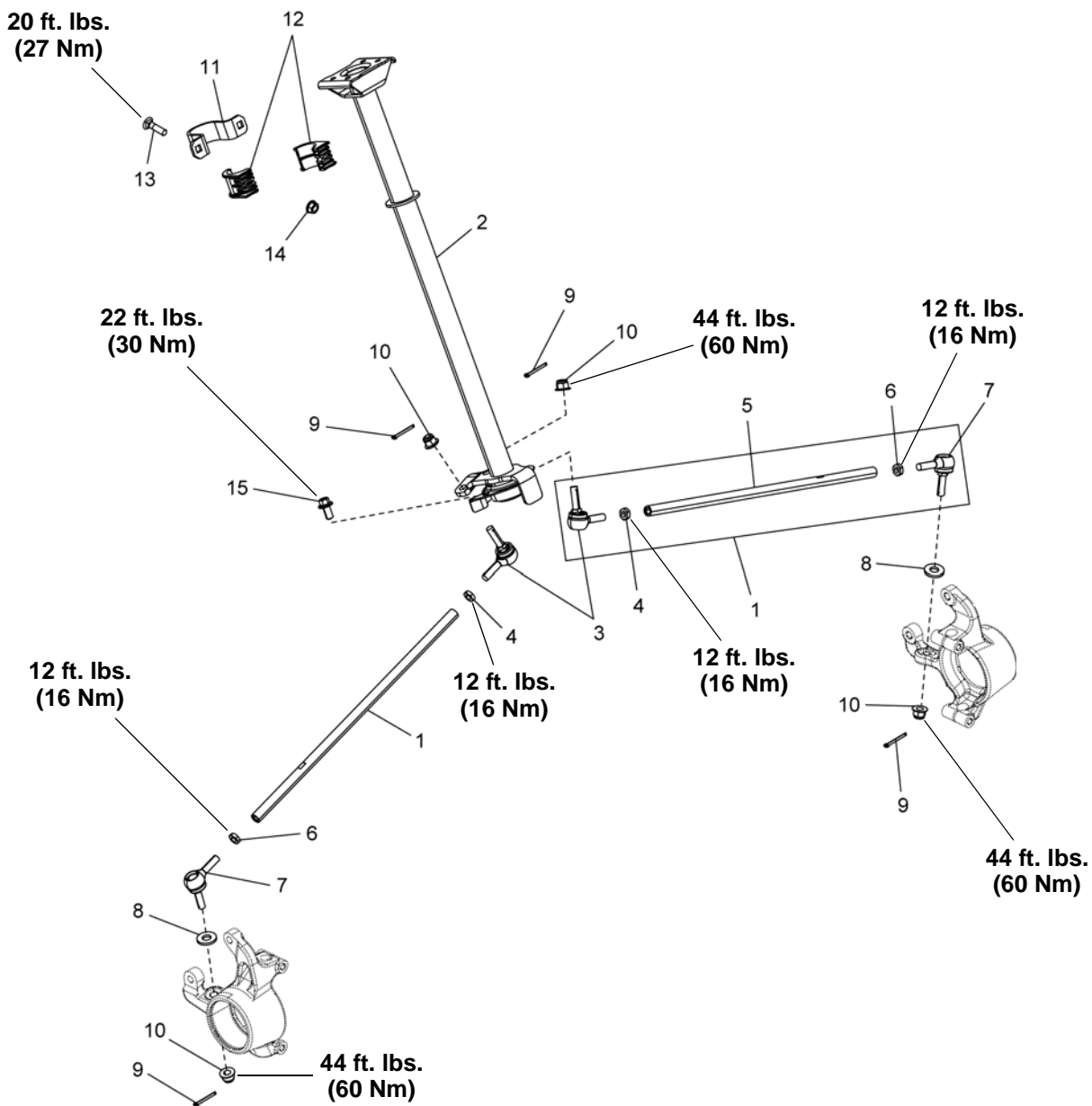

REF.	DESCRIPTION	REF.	DESCRIPTION
1	Tie Rod	9	Cotter Pin
2	Steering Post	10	Nut
3	Rod End, RH	11	Upper Steering Bracket
4	Jam Nut, RH	12	Upper Steering Bushing
5	Tie Rod Assembly	13	Carriage Bolt
6	Jam Nut LH	14	Nut
7	Rod End, LH	15	Bolt
8	Washer		

STEERING / SUSPENSION

STEERING (EPS MODELS)

Upper Steering Post Removal

1. Remove the front rack and front cover (see Chapter 9).
2. Remove the upper and lower headlight pods from the handlebar bracket (see Chapter 9).

IMPORTANT: Take note of all vent line, wire harness and throttle cable routing for reassembly purposes.

3. Remove the (4) fasteners retaining the handlebar bracket and block to the steering post.

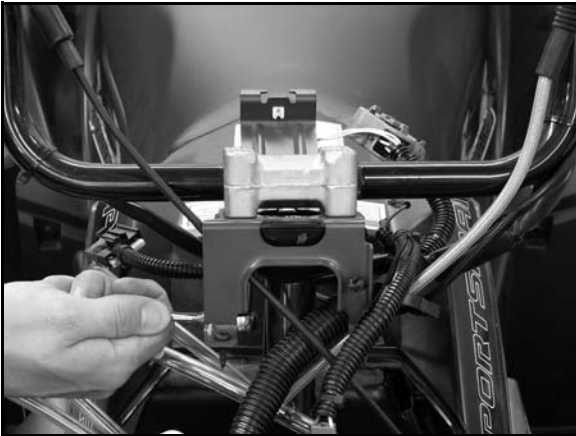

4. Carefully remove the handlebar assembly from the steering post and place it on the front cab.

IMPORTANT: Take care not to bend the throttle cable or brake line while the handlebar is removed.

5. Remove the bolt retaining the upper steering post to the power steering unit.

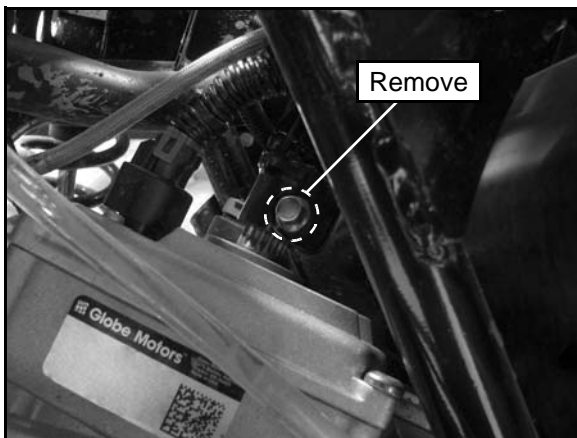

6. Remove the (2) fasteners retaining the upper steering post bushing bracket.

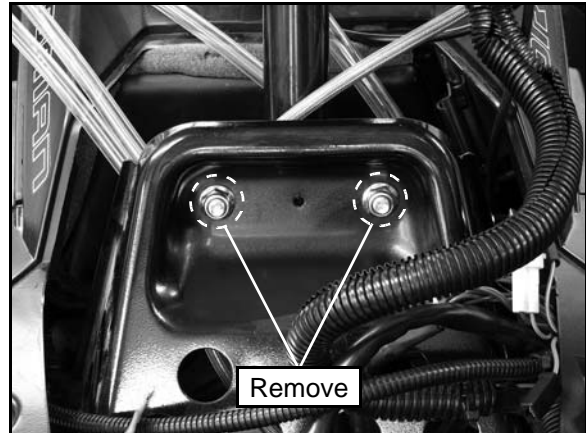

7. Lift the upper steering post up from the power steering unit remove it from the chassis.

Upper Steering Post Installation

1. Reverse the "Upper Steering Post Removal" procedure to reinstall the steering post.
2. Apply anti-seize to the shaft splines to aid assembly.
3. Align the mark on the upper steering post with the skip tooth spline on the upper power steering shaft upon installation.

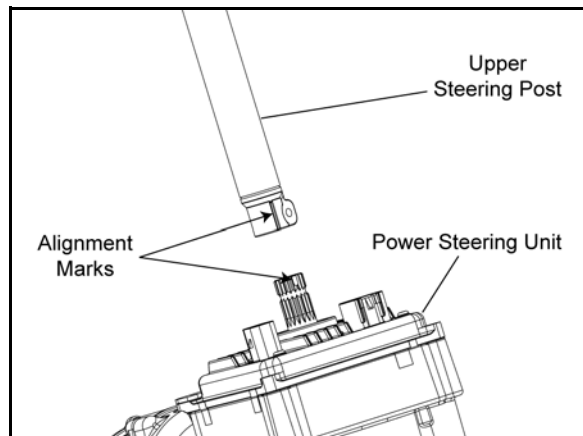

CAUTION

Striking the steering post can permanently damage the EPS unit and cause a Power Steering Fault.

4. Refer to "Steering Exploded View (EPS Models)" for torque values.

NOTE: Make sure to route all vent lines, wire harness and throttle cable correctly into the lower headlight pod.

5. When installing the headlight into the lower pod, be sure to install the O-rings prior to installing the headlight.
6. Place the headlight into the lower pod mounting tabs and press firmly until the headlight snaps into place.
7. Lift the O-ring up and over the headlight mounting tab to secure it.

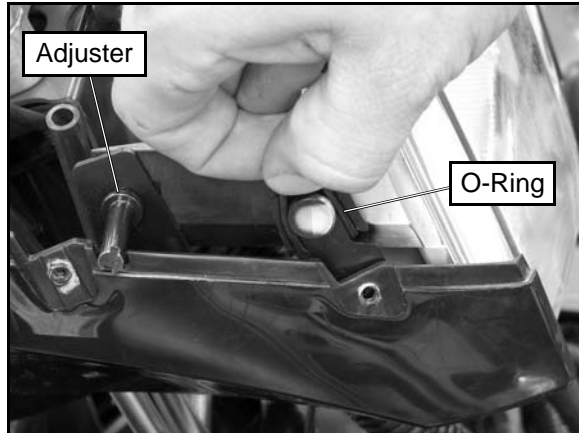

8. Reinstall the adjustment screw and be sure to adjust the upper headlight after reassembly.

NOTE: Refer to Chapter 9 when reassembling the upper and lower headlight pods.

Power Steering Unit Removal

1. Remove the front rack and front cover (see Chapter 9).
2. Remove both front mud guards and right-hand footwell (see Chapter 9).
3. Locate the power steering unit through the front left wheel well area.

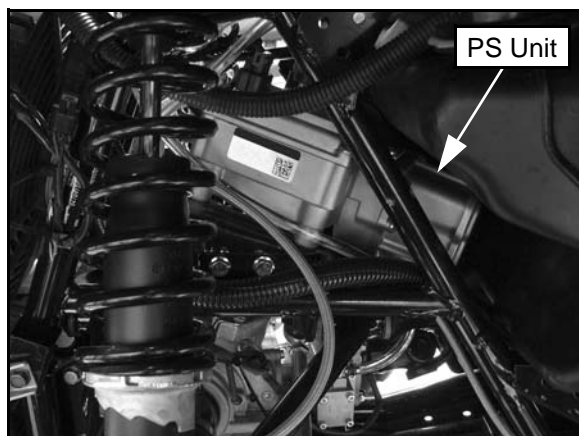

4. Remove the bolt retaining the upper steering post to the power steering unit.

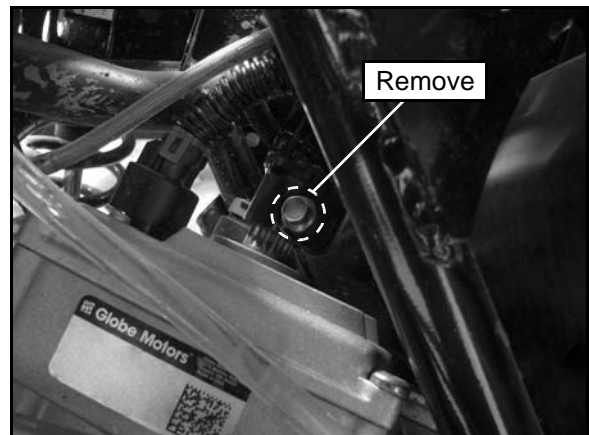

5. Remove the (2) fasteners retaining the upper steering post bushing bracket.

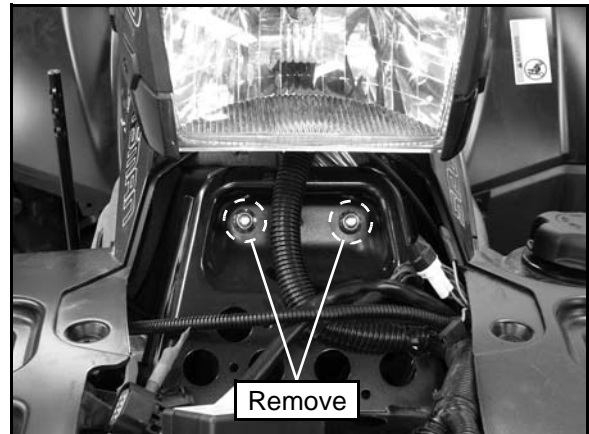

6. Lift the upper steering post up from the power steering unit.
7. Locate and remove the two fuel tank mounting screws through the steering post opening.

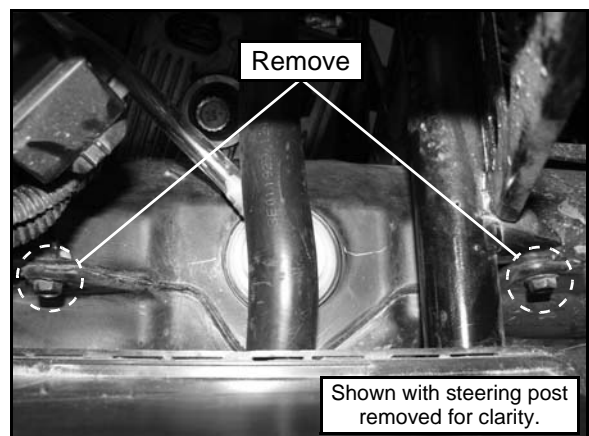

8. Disconnect the fuel line and wire harness from the fuel pump (see Chapter 3).

STEERING / SUSPENSION

9. Loosen the hose clamp and remove the fuel inlet hose from the fuel tank. Cover the tank inlet and remove the fuel tank assembly out the right side (see Chapter 3).
10. Disconnect the (2) electrical harnesses from the power steering unit.

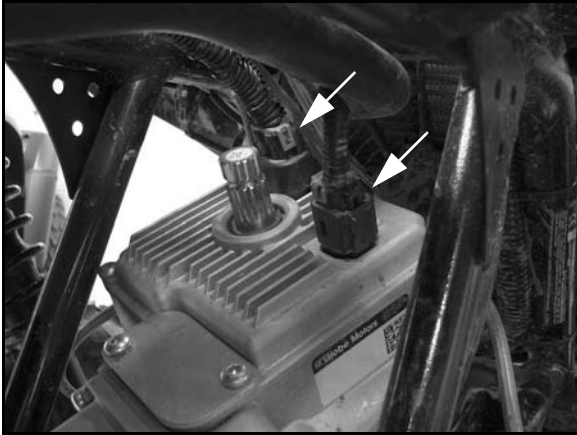

11. Remove the (4) mounting fasteners that retain the power steering unit to the frame.

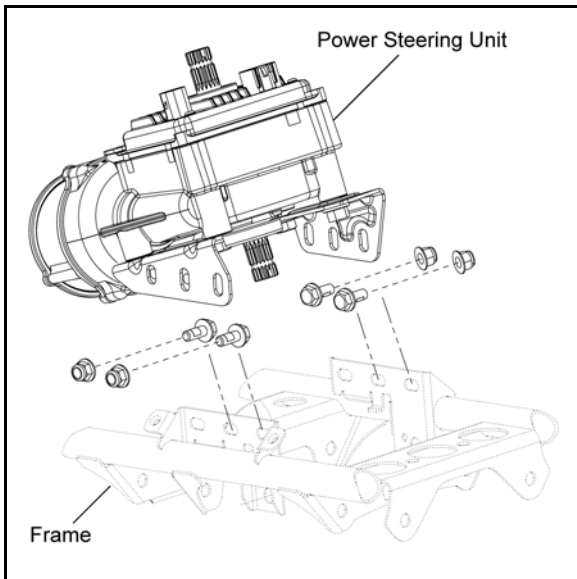

12. Carefully lift the power steering unit up to disengage the lower steering coupler and remove it from the chassis.

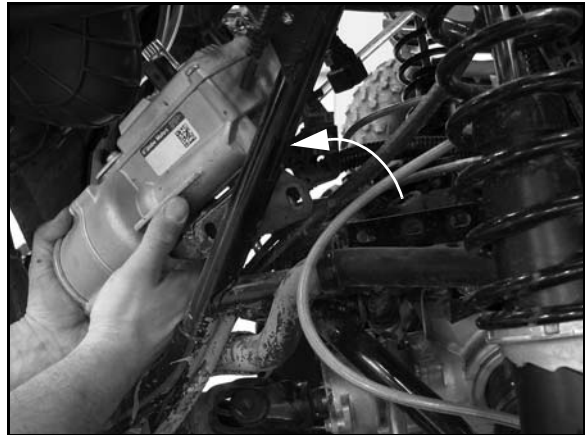

Power Steering Unit Installation

1. Position the vehicle so the front wheels are pointing straight forward.
2. Clean the lower steering post so the alignment mark is visible. Mark the skip tooth spline on the lower power steering shaft.
3. Apply anti-seize to the shaft splines to aid assembly.
4. Align the two marks and install the power steering unit (see Figure 10-1).

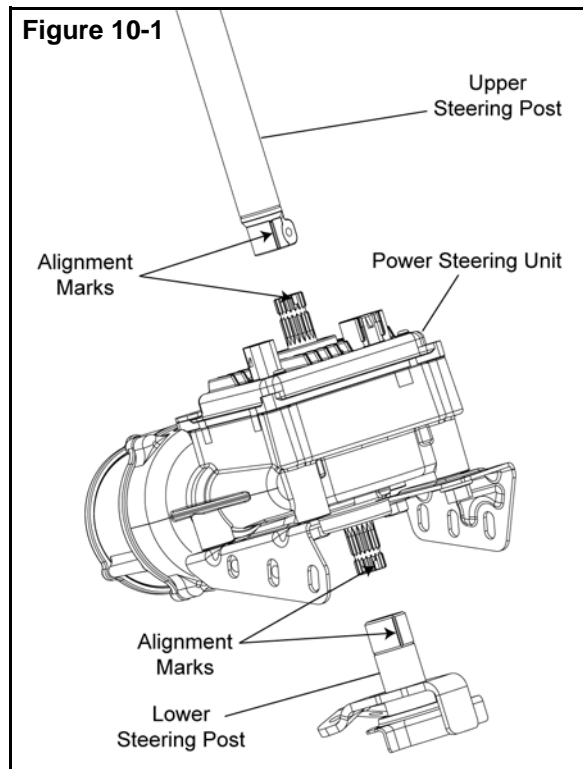

5. Install the (4) mounting fasteners and torque fasteners to specification. Refer to “Steering Exploded View (EPS Models)”.
6. Reconnect the (2) electrical harnesses to the power steering unit.

CAUTION

The 8-way connector, two rows of four pins, does not have a channeled lock on both sides, allowing it to be installed 180° from its intended position. The connector will not positively engage or snap into place while in the wrong position, but can still be installed. If the connector is not installed correctly, the Power Steering Unit will not function.

7. Align the mark on the upper steering post with the skip tooth spline on the upper power steering shaft upon installation (see **Figure 10-1**).
8. Apply anti-seize to the shaft splines to aid assembly.
9. Position the upper steering post on the shaft so the pinch bolt is aligned with the recess in the power steering shaft.

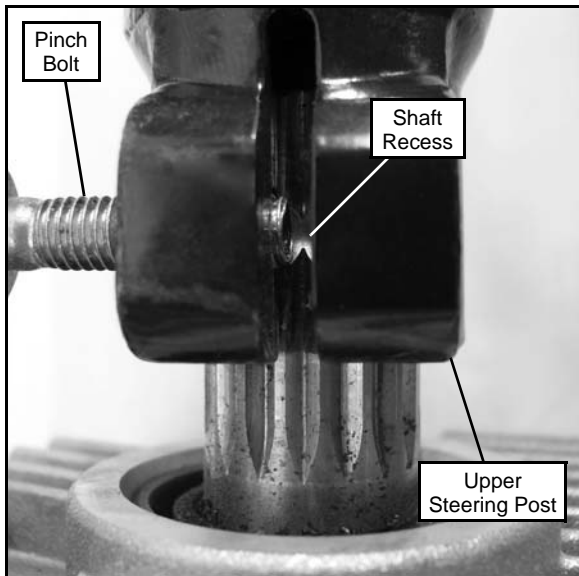



CAUTION

Striking the steering post can permanently damage the EPS unit and cause a Power Steering Fault.

10. Install the pinch bolt and torque to specification. Refer to “Steering Exploded View (EPS Models)”.

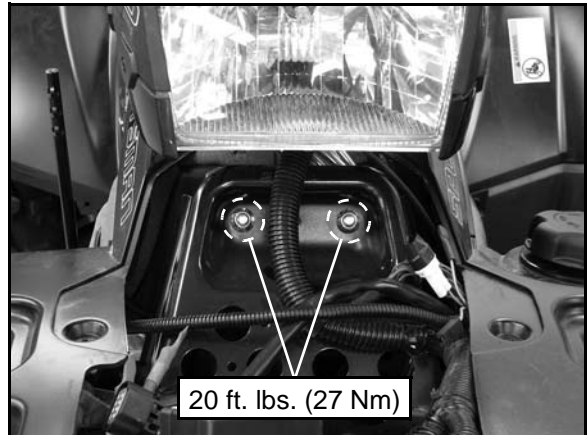
11. Install the fuel tank assembly, fuel line and reconnect the fuel pump harness (see Chapter 3).
12. Reinstall the upper steering post bushing bracket and torque the (2) fasteners to specification.



 = T

**Steering Post to Bulkhead Bolts:
20 ft. lbs. (27 Nm)**

13. Turn the ignition key to the “ON” position and move the handlebar from left to right several times to ensure the power steering doesn’t bind. If binding occurs:
 - Loosen the (4) mounting fasteners
 - Move handlebars from left to right several times to position the power steering unit
 - Torque the (4) mounting fasteners to specification and check the steering operation for binding again
 - If no binding is present, proceed; if binding is still present, repeat this procedure.
14. Install both front mud guards and right-hand footwell (see Chapter 9).
15. Install the front rack and front cover (see Chapter 9).

STEERING / SUSPENSION

Steering Exploded View (EPS Models)

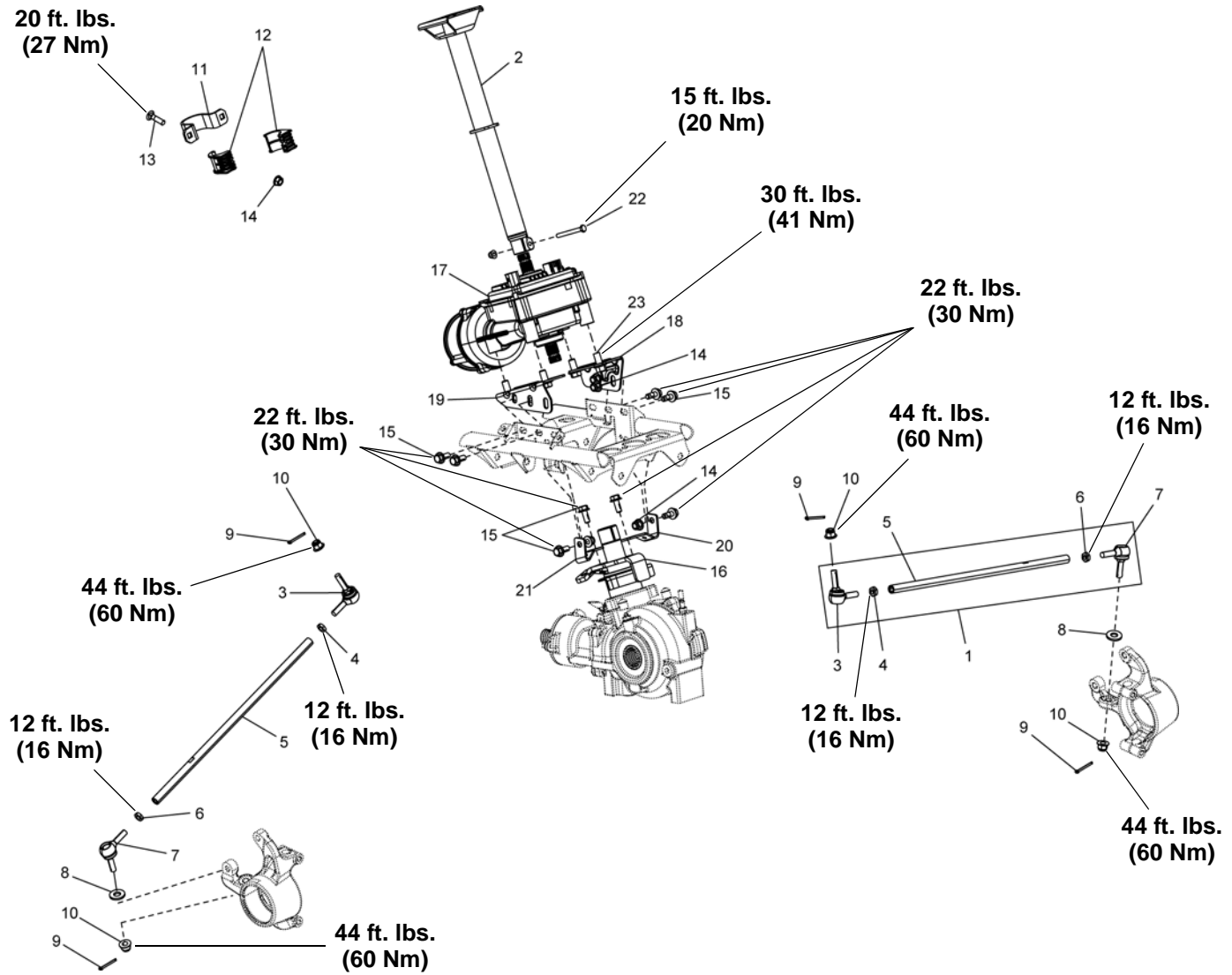

REF.	DESCRIPTION	REF.	DESCRIPTION
1	Tie Rod Assembly	13	Carriage Bolt
2	Upper Steering Post	14	Nut
3	Rod End, RH	15	Bolt
4	Jam Nut, RH	16	Lower Steering Post
5	Tie Rod	17	Power Steering Assembly
6	Jam Nut, LH	18	Power Steering Bracket, LH
7	Rod End, LH	19	Power Steering Bracket, RH
8	Washer	20	Front Drive Bracket, LH
9	Cotter Pin	21	Front Drive Bracket, RH
10	Nut	22	Bolt
11	Upper Steering Bracket	23	Bolt
12	Upper Steering Bushing		

STEERING TIE ROD

Tie Rod / Tie Rod End Replacement

Use the following procedure to replace the tie rod assembly or tie rod ends.

1. Elevate front of vehicle and safely support machine under the frame area.

 CAUTION
Serious injury may result if machine tips or falls. Be sure machine is secure before beginning this service procedure. Always wear eye protection.

2. Remove the (4) wheel nuts and remove the front wheel(s).
3. Remove the cotter pins (A) and tie rod end fasteners (B).
4. Remove the tie rod assembly (C).

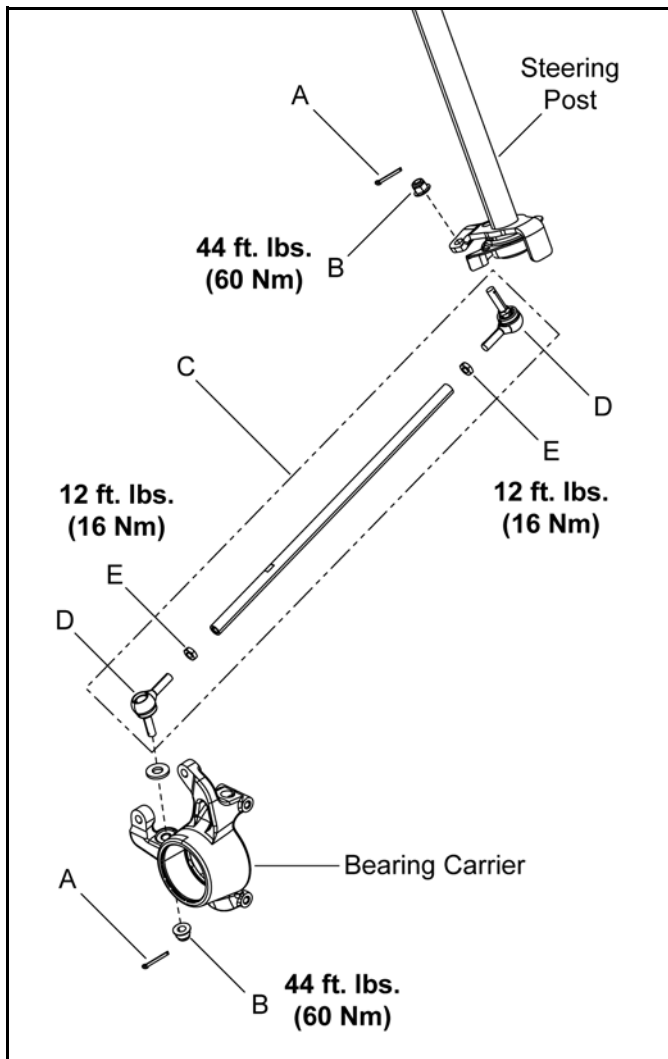

- If replacing just the tie rod end (D), loosen the jam nut (E) and remove the rod end.
- Install new rod end and torque jam nuts to specification.

5. Install the new tie rod assembly (C).
6. Install the rod ends and fasteners (B) in the proper orientation (see illustration).
7. Torque the tie rod end fasteners to specification and install new cotter pins.

 = T
Tie Rod End Fastener: 44 ft. lbs. (60 Nm)

8. Install the front wheel(s) and wheel nuts. Torque wheel nuts to specification.

 = T
Wheel Nuts: Steel Wheels: 45 ft. lbs. (61 Nm) Aluminum Wheels: 75 ft. lbs. (102 Nm)

9. Check wheel toe alignment and adjust as necessary (see Chapter 2).

STEERING / SUSPENSION

FRONT A-ARMS

Exploded View

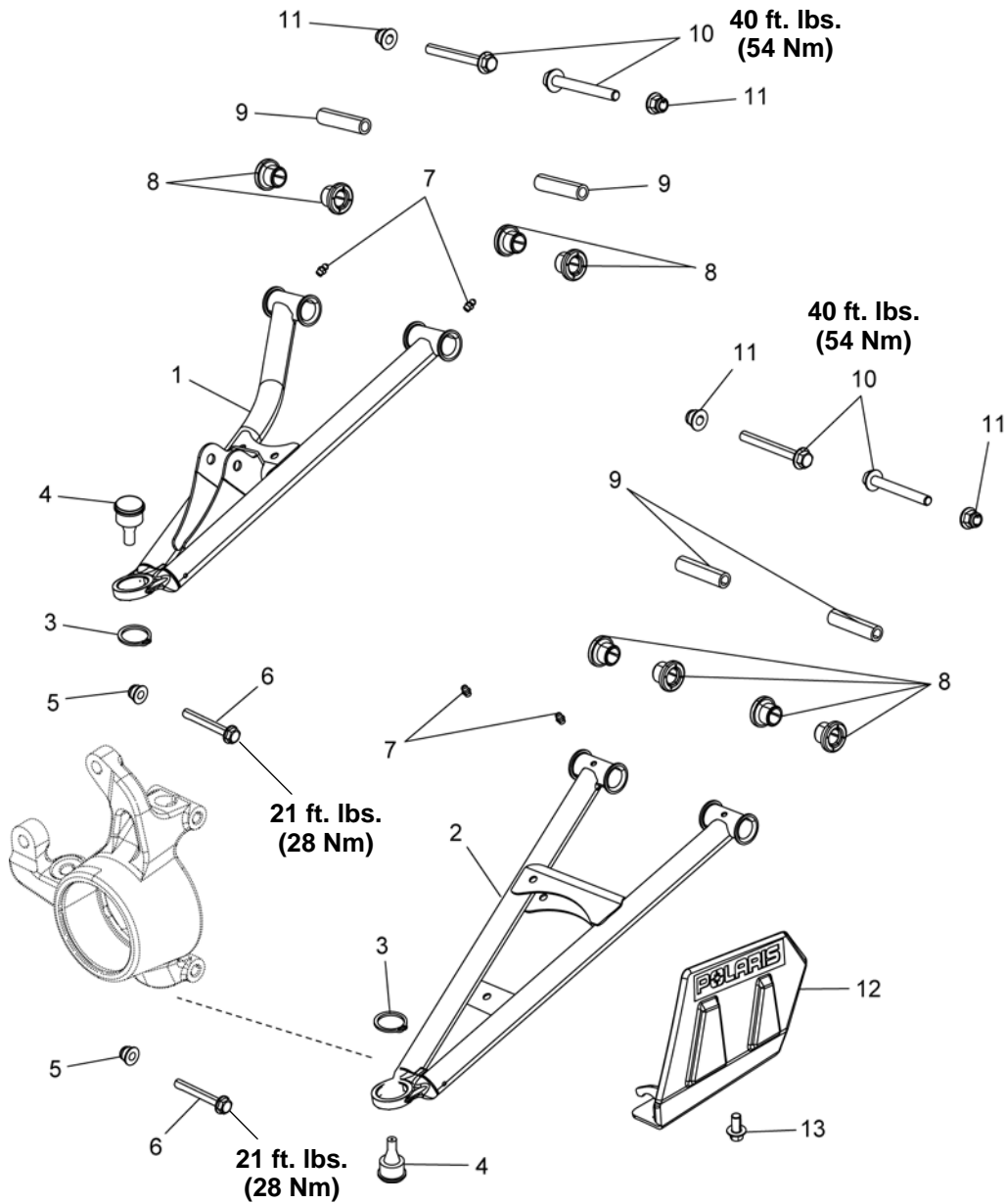

REF.	DESCRIPTION	REF.	DESCRIPTION
1	Upper A-arm	8	Bushing
2	Lower A-arm	9	Pivot Shaft
3	Retaining Ring	10	Bolt
4	Ball Joint	11	Nut
5	Nut	12	CV Shield
6	Bolt	13	Screw
7	Grease Fitting		

Removal / Replacement

The following procedure details upper and lower A-arm removal and replacement on one side of the vehicle.

1. Elevate and safely support the front of the vehicle and remove the front wheel.
2. Remove the lower shock fastener from the upper A-arm.

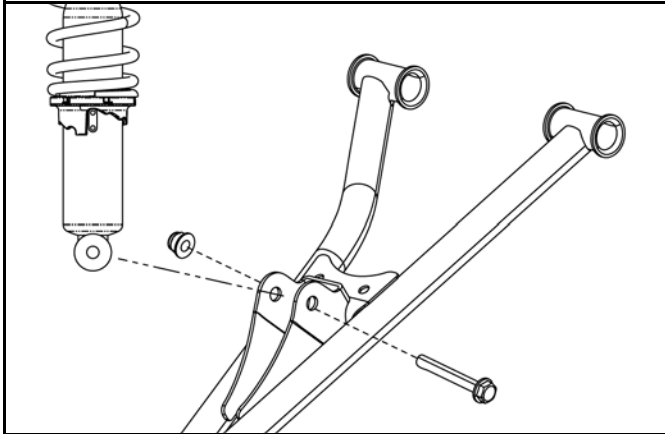

3. Remove the upper ball joint pinch bolt from the front bearing carrier (see **Figure 10-2**).

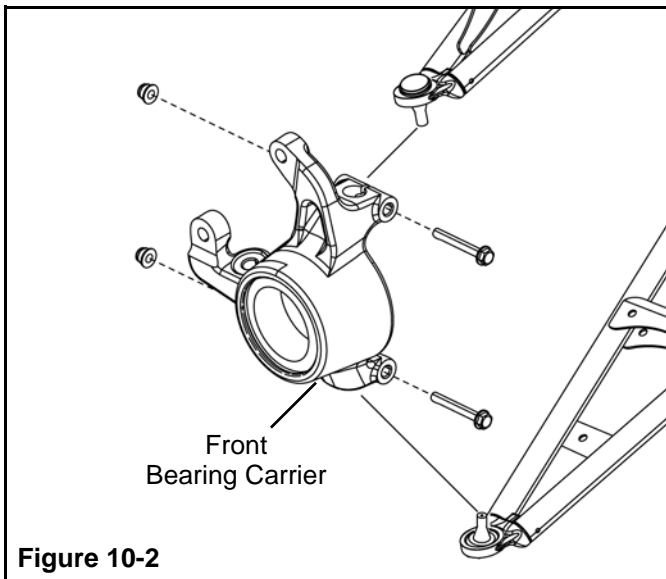

Figure 10-2

4. Remove the brake line retainer from the upper A-arm.
5. Using a soft face hammer, tap on bearing carrier to loosen the upper ball joint end while lifting upward on the upper A-arm. Completely remove the ball joint end from the bearing carrier.
6. Remove the upper A-arm through-bolt fasteners and remove the A-arm from the vehicle (see “Exploded View”).
7. Examine A-arm bushings and pivot shafts (see “Exploded View”). Replace if worn and discard the hardware.

WARNING

The locking agent on the existing bolts was destroyed during removal. DO NOT reuse old hardware. Serious injury or death could result if fasteners come loose during operation.

8. If not replacing the A-arm, thoroughly clean the A-arm and pivot shafts.
9. Install new ball joint into A-arm. Refer to “Ball Joint Replacement” section.
10. Insert new bushings and pivot shafts into the new A-arm.
11. Install new upper A-arm assembly onto vehicle frame. Torque new bolts to **40 ft. lbs. (54 Nm)**.
12. Insert upper A-arm ball joint end into the bearing carrier. Install the upper ball joint pinch bolt into the bearing carrier and torque bolt to **21 ft. lbs. (28 Nm)**.
13. Attach shock to A-arm with new fastener. Torque lower shock bolt to **37 ft. lbs. (50 Nm)**.
14. Remove the lower ball joint pinch bolt from the front bearing carrier (see **Figure 10-2**).
15. Using a soft face hammer, tap on bearing carrier to loosen the lower A-arm ball joint end while pushing downward on the lower A-arm. Completely remove the ball joint end from the bearing carrier.
16. Remove the lower A-arm through-bolt fasteners and remove the lower A-arm from the vehicle.
17. Examine A-arm bushings and pivot shafts (see “Exploded View”). Replace if worn and discard the hardware.
18. If not replacing the A-arm, thoroughly clean the A-arm and pivot shafts.
19. Install new ball joint into A-arm. Refer to “Ball Joint Replacement” section.
20. Insert new bushings and pivot shafts into the new A-arm.
21. Install new lower A-arm assembly onto vehicle frame. Torque new bolts to **40 ft. lbs. (54 Nm)**.
22. Insert lower A-arm ball joint end into the bearing carrier. Install the lower ball joint pinch bolt into the bearing carrier and torque bolt to **21 ft. lbs. (28 Nm)**.
23. Grease all (4) A-arm grease fittings after reassembly.

WARNING

Upon A-arm installation completion, test vehicle at low speeds before putting into service.

STEERING / SUSPENSION

BALL JOINT SERVICE

Removal

IMPORTANT: Do not reuse a ball joint if it has been removed for any reason. If removed, it must be replaced. Use this removal procedure only when replacing the ball joint.

1. The A-arm must be removed to perform this procedure (see "FRONT A-ARMS - Removal / Replacement").

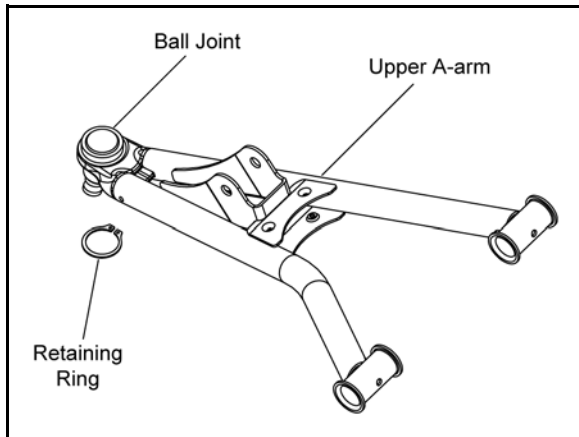

2. Remove the retaining ring from the ball joint.
3. A driver must be used for the removal of the ball joint. Use the dimensions below to fabricate or locate the correct size driver to use in the following process.

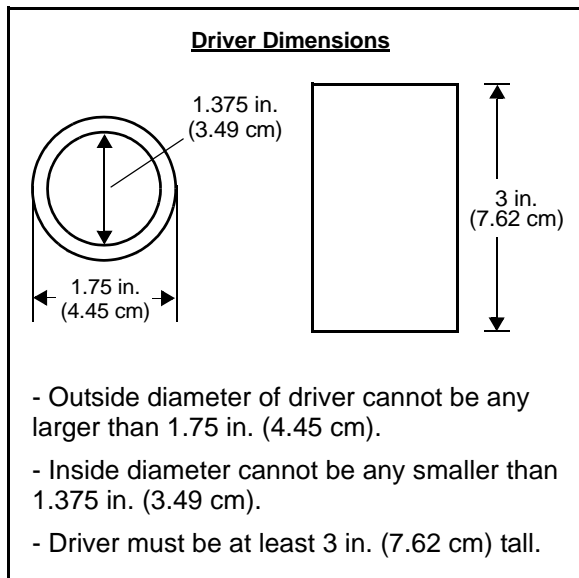

Installation

1. Place the A-arm in the correct position for ball joint installation. Face the A-arm end flat on top of the driver. Carefully drive the ball joint into place until the ball joint

4. Use a press and correct size driver to remove the ball joint from the A-arm.

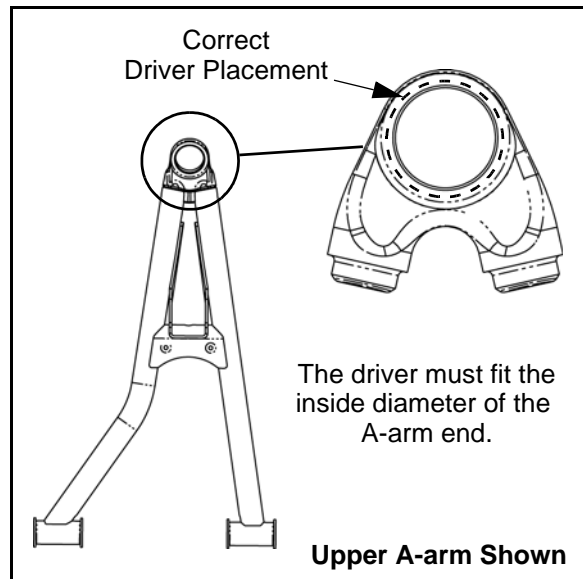

NOTE: The driver must fit the ball joint housing in the A-arm. This will allow the ball joint to be properly pressed out of the A-arm without damaging the A-arm.

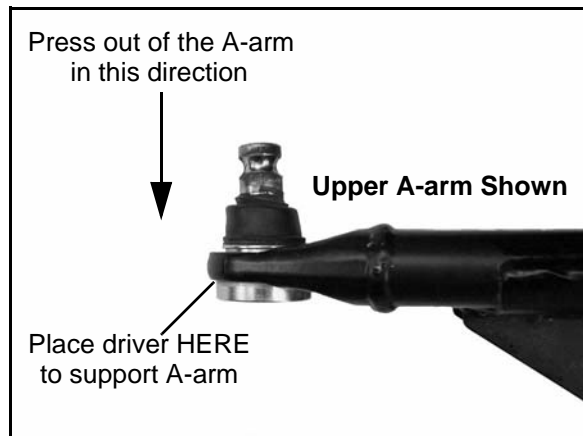

is properly seated.

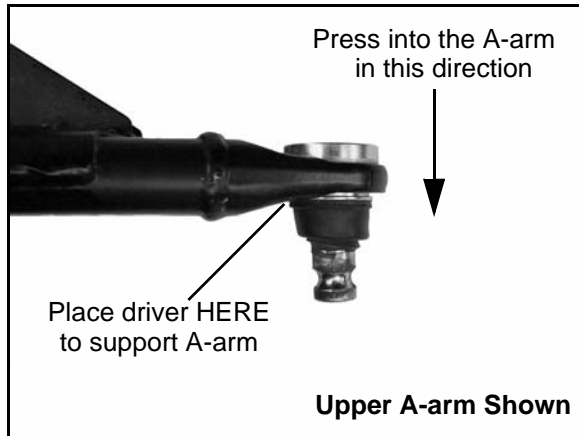

2. After the new ball joint is installed into the A-arm, install a new retaining ring.

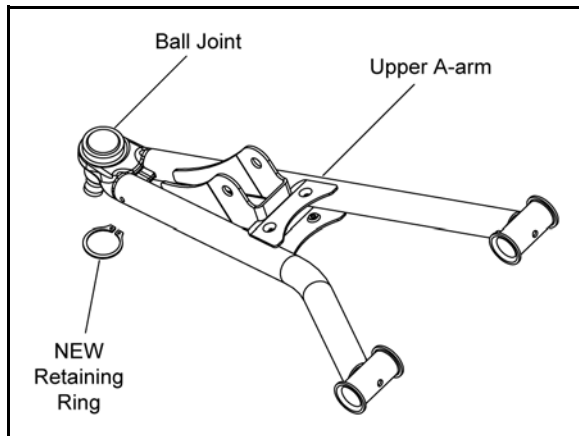

3. Reinstall the A-arm (see "FRONT A-ARMS - Removal / Replacement").
4. Repeat the ball joint service procedure for any additional A-arm ball joint replacements.

STEERING / SUSPENSION

REAR A-ARMS

Exploded View

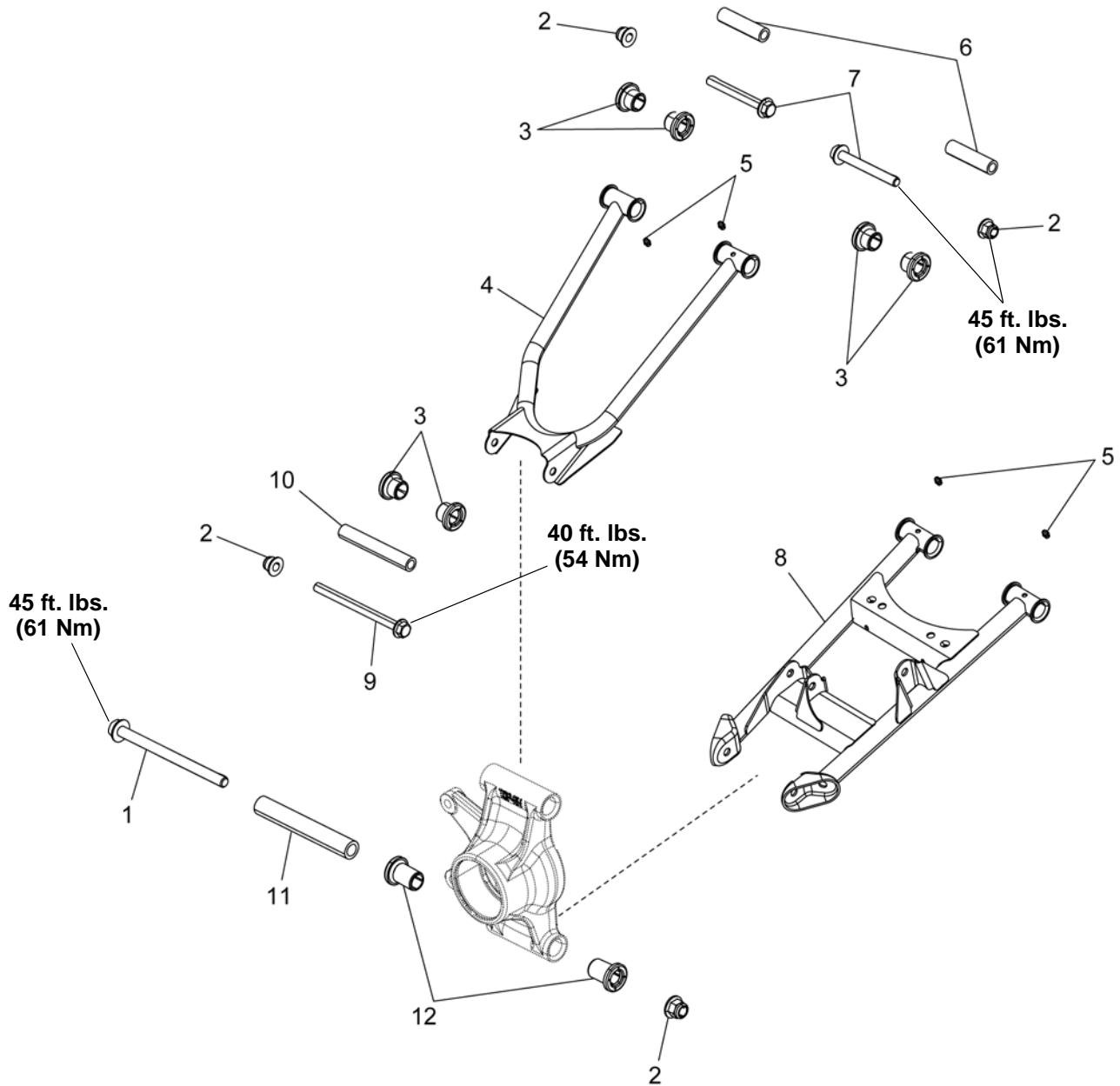

REF.	DESCRIPTION	REF.	DESCRIPTION
1	Bolt	7	Bolt
2	Nut	8	Lower A-arm
3	Bushing	9	Bolt
4	Upper A-arm	10	Pivot Shaft, Upper
5	Grease Fitting	11	Pivot Shaft, Lower
6	Pivot Shaft	12	Bushing, Lower

Removal

The following procedure details upper and lower A-arm removal and replacement on one side of the vehicle.

1. Elevate and safely support the rear of the vehicle and remove the rear wheel.

Upper A-arm Removal

2. Remove the through-bolt fastener attaching the upper A-arm to the bearing carrier (see "Exploded View").
3. Remove the through-bolt fasteners attaching the upper A-arm to the frame and remove the A-arm from the vehicle.
4. Examine A-arm and bearing carrier bushings and pivot shafts (see "Exploded View"). Replace if worn and discard the hardware.

! WARNING

The locking agent on the existing bolts was destroyed during removal. **DO NOT** reuse old hardware. Serious injury or death could result if fasteners come loose during operation.

5. If not replacing the A-arm, thoroughly clean the a-arm and pivot shafts.
6. Insert new bushings and pivot shafts into the new A-arm.

Lower A-arm Removal

7. Remove the through-bolt fastener attaching the lower A-arm to the bearing carrier (see "Exploded View").
8. Remove the lower shock fastener from the lower A-arm.

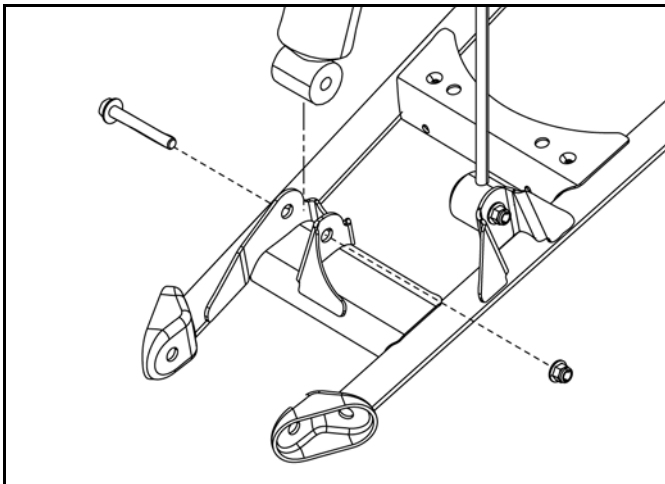

9. Remove the brake line retainer from the lower A-arm.

10. Remove the fastener retaining the stabilizer linkage to the lower A-arm.

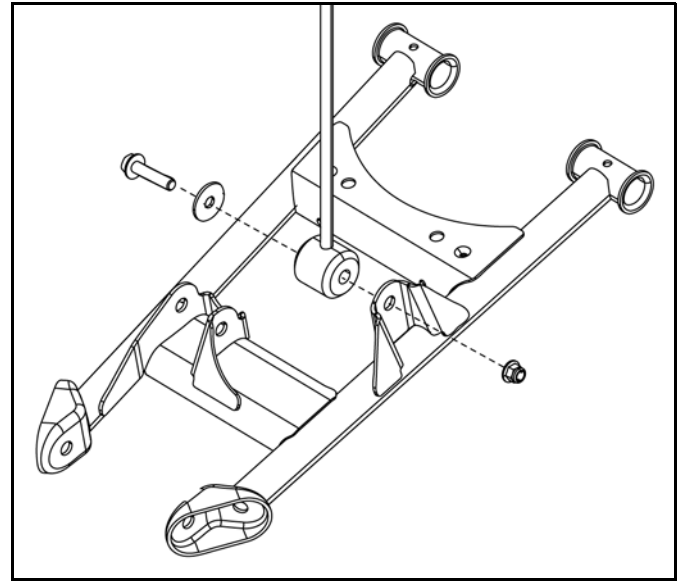

11. Remove the through-bolt fasteners attaching the lower A-arm to the frame and remove the A-arm from the vehicle.
12. Examine A-arm and bearing carrier bushings and pivot shafts (see "Exploded View"). Replace if worn and discard the hardware.
13. If not replacing the A-arm, thoroughly clean the a-arm and pivot shafts.
14. Insert new bushings and pivot shafts into the new A-arm.

Installation

1. Install upper and lower A-arm assemblies onto the vehicle frame. Torque new fasteners to **45 ft. lbs. (61 Nm)**.
2. Grease all (4) A-arm grease fittings after reassembly.
3. Attach lower A-arm to bearing carrier. Torque new fastener to **45 ft. lbs. (61 Nm)**.
4. Attach upper A-arm to bearing carrier. Torque new fasteners to **40 ft. lbs. (54 Nm)**.
5. Grease both rear bearing carrier fittings after reassembly.
6. Route brake line on top of lower A-arm and install retainer.
7. Reinstall the lower portion of the shock and lower portion of the stabilizer linkage to the lower A-arm. Torque mounting fasteners to **37 ft. lbs. (50 Nm)**.
8. Install wheel and torque wheel nuts to specification.

! WARNING

Upon A-arm installation completion, test vehicle at low speeds before putting into service.

STEERING / SUSPENSION

REAR STABILIZER BAR

Exploded View

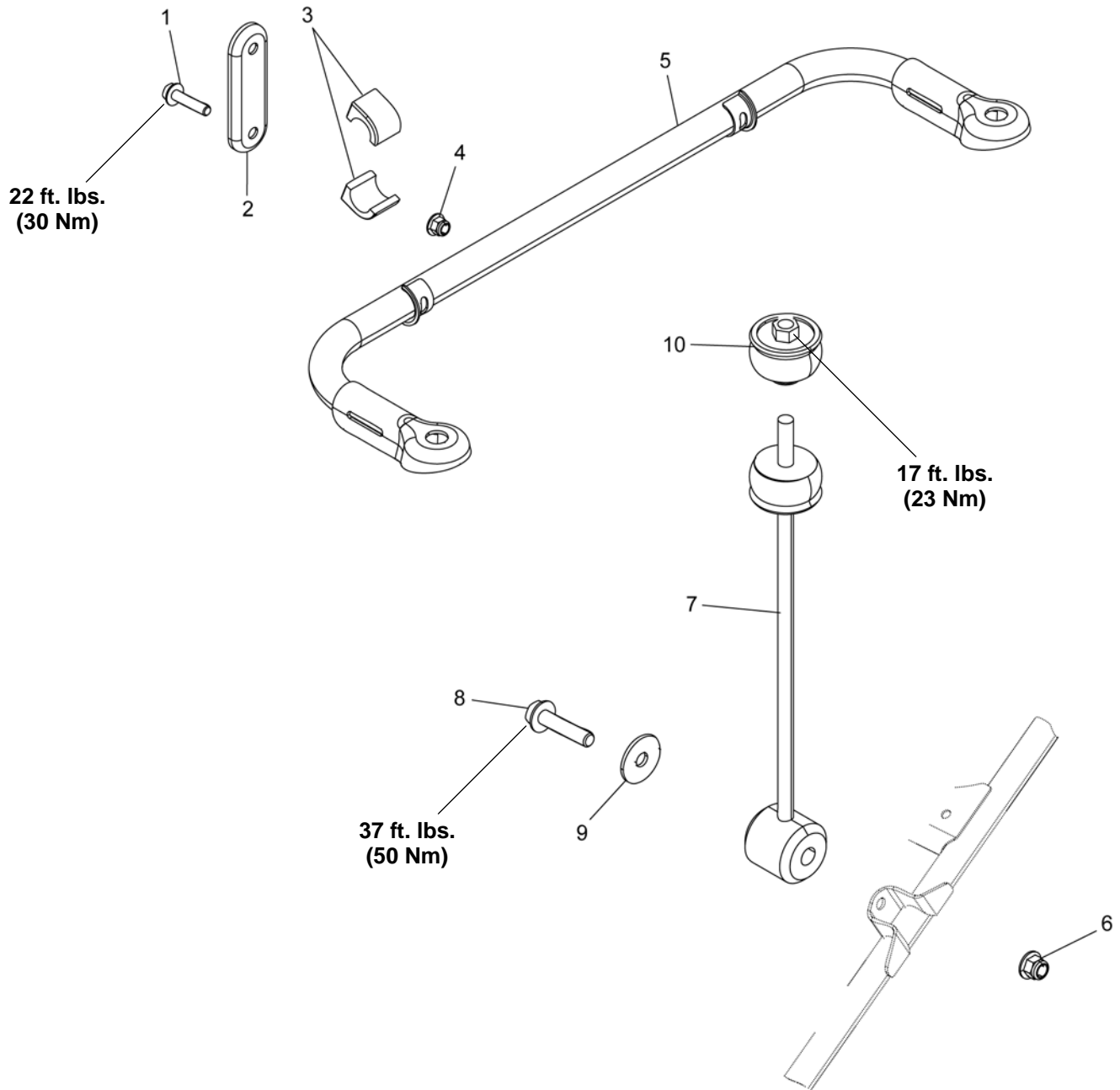

REF.	DESCRIPTION	REF.	DESCRIPTION
1	Bolt	6	Nut
2	Stabilizer Bar Bracket	7	Linkage, Stabilizer Bar
3	Bushing, Stabilizer Bar	8	Bolt
4	Nut	9	Flat Washer
5	Stabilizer Bar	10	Bushing, Linkage

Linkage Removal / Installation

1. Elevate rear of vehicle and safely support machine under the frame area.



Serious injury may result if machine tips or falls. Be sure machine is secure before beginning this service procedure. Always wear eye protection.

2. Remove the (4) wheel nuts and remove the rear wheel.
3. Remove the upper linkage bushing.

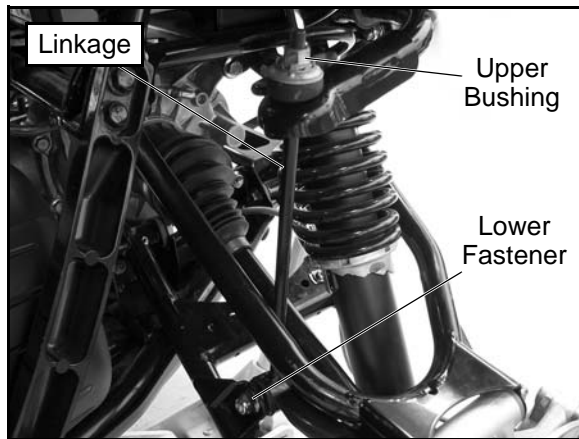

4. Remove the lower linkage fastener and remove the stabilizer linkage.
5. Reverse this procedure to reinstall the stabilizer linkage. Refer to the "REAR STABILIZER BAR - Exploded View" for torque values.

Stabilizer Bar Removal / Installation

1. Remove the (2) exhaust springs from the rear portion of the exhaust silencer.

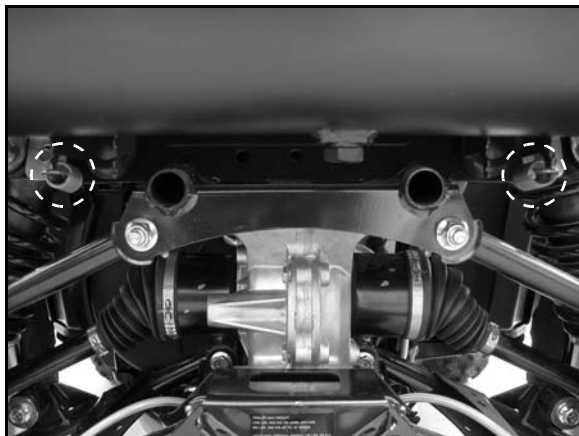

2. Remove the (2) exhaust springs that retain the exhaust pipe to the silencer.

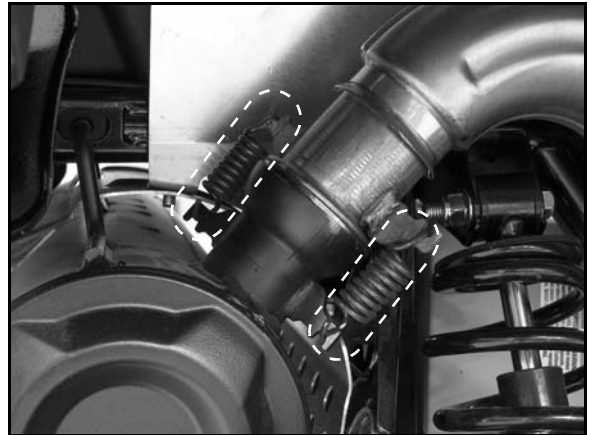

3. Remove the exhaust silencer from the vehicle through the right rear wheel well.

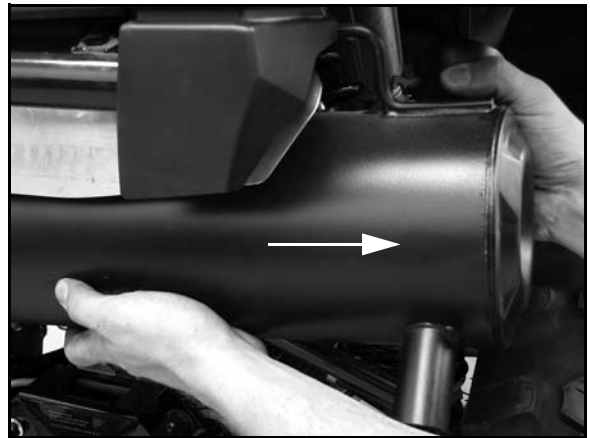

NOTE: Lift upward slightly on the exhaust pipe to allow for enough clearance to remove the silencer.

4. Remove the (4) screws retaining the exhaust heat shield and remove the shield from the chassis.

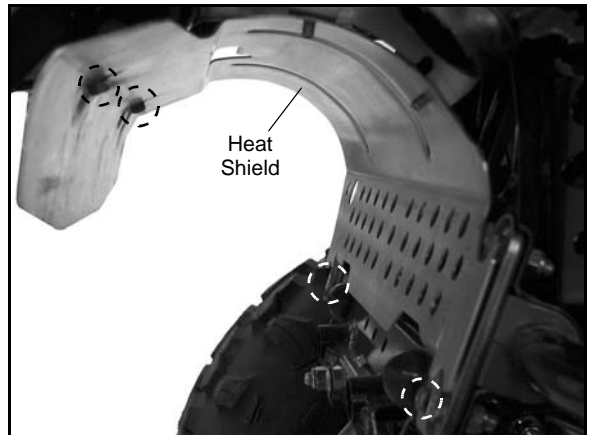

STEERING / SUSPENSION

- Remove the upper bushing from the stabilizer linkage on each side of the vehicle.

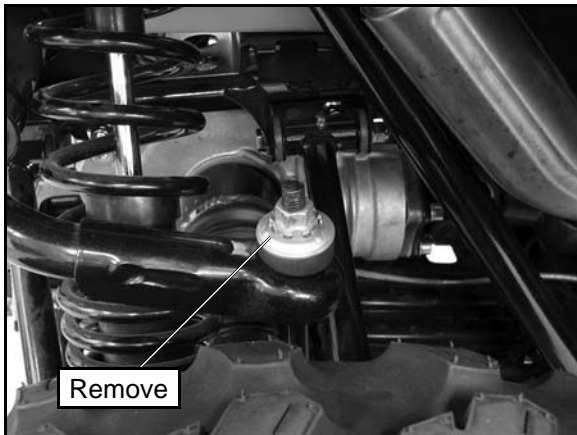

- Remove the (4) fasteners retaining the stabilizer bar bracket to the frame.

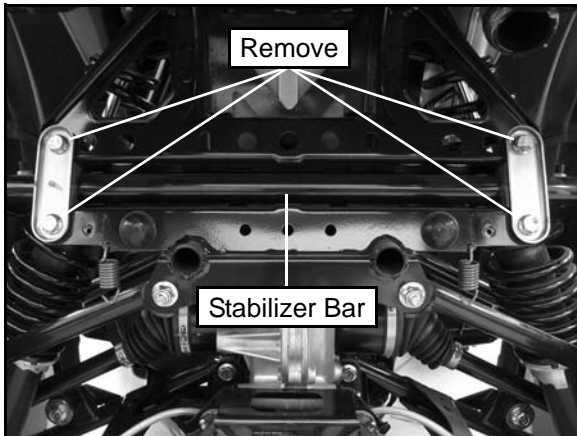

- Remove the stabilizer bar from the frame.
- Inspect the stabilizer bar for straightness. Inspect the bushings and replace if needed.
- Inspect the rubber bushings on the stabilizer linkage(s) and replace if needed.
- Reverse this procedure to reinstall the stabilizer bar. Refer to the "REAR STABILIZER BAR - Exploded View" for torque values.

SHOCKS / SPRINGS

Exploded View

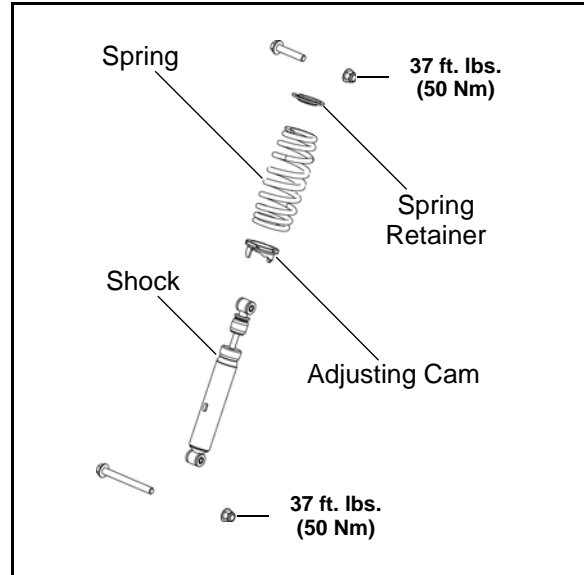

Shock Removal / Installation

- Elevate the vehicle off the ground to relieve the suspension load.
- Remove the upper and lower fasteners retaining the shock and remove the shock from the vehicle.
- Reverse the procedure to reinstall the shock. Torque new fasteners to **37 ft. lbs. (50 Nm)**.

Shock / Spring Replacement

- Using a spring compressor, compress the shock spring far enough to remove the spring retainer.

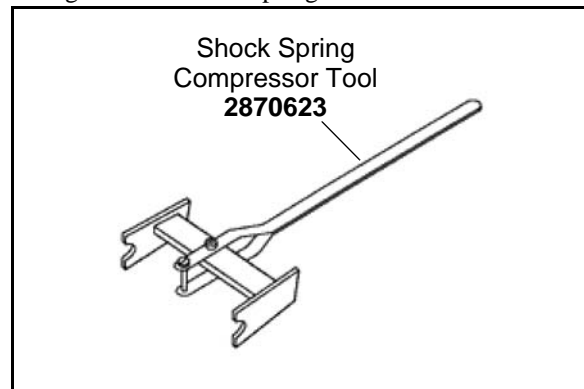

- Remove the spring and adjusting cam from the existing shock and install components onto the new shock.
- Compress the shock spring and install the spring retainer.
- Reinstall the shock onto the vehicle and torque new fasteners to **37 ft. lbs. (50 Nm)**.

CHAPTER 11

BRAKES

SPECIFICATIONS	11.2
GENERAL BRAKE SPECIFICATIONS	11.2
GENERAL TORQUE SPECIFICATIONS	11.2
SPECIAL TOOLS / BRAKE FLUID	11.2
BRAKE SYSTEM SERVICE NOTES	11.3
BRAKE NOISE TROUBLESHOOTING	11.3
HYDRAULIC BRAKE SYSTEM OPERATION	11.4
BRAKE SYSTEM EXPLODED VIEW	11.4
BRAKE CALIPER EXPLODED VIEW	11.5
HAND MASTER CYLINDER EXPLODED VIEW	11.5
BRAKE BLEEDING	11.6
FLUID REPLACEMENT	11.6
BLEEDING PROCEDURE	11.6
HAND BRAKE MASTER CYLINDER	11.8
REMOVAL / DISASSEMBLY / INSTALLATION	11.8
BRAKE SWITCH REPLACEMENT	11.8
FOOT BRAKE MASTER CYLINDER	11.9
FOOT MASTER CYLINDER REMOVAL / INSTALLATION	11.9
BRAKE PEDAL REMOVAL / INSTALLATION	11.9
BRAKE PADS	11.10
PAD REMOVAL / INSPECTION / INSTALLATION	11.10
BRAKE BURNISHING PROCEDURE	11.11
CALIPER SERVICE	11.11
CALIPER REMOVAL / DISASSEMBLY	11.11
CALIPER INSPECTION	11.12
CALIPER REASSEMBLY / INSTALLATION	11.13
BRAKE DISC SERVICE	11.14
DISC INSPECTION / REMOVAL / REPLACEMENT	11.14
TROUBLESHOOTING	11.16

sales@midwestmanuals.com

www.midwestmanuals.com

BRAKES**SPECIFICATIONS****General Brake Specifications****FRONT BRAKES**

Item	Standard	Service Limit
Brake Pad Thickness	--	.040" / 1 mm
Brake Disc Thickness	.187" / 4.75 mm	.167" / 4.24 mm
Brake Disc Thickness Variance Between Measurement	--	.002" / .051 mm
Brake Disc Runout	--	.010" / .254 mm
Caliper Piston Diameter	1.186" / 30.12 mm	1.184" / 30.07 mm
Caliper Bore Diameter	1.192" / 30.28 mm	1.194" / 30.33 mm

REAR BRAKES

Item	Standard	Service Limit
Brake Pad Thickness	--	.040" / 1 mm
Brake Disc Thickness	.187" / 4.75 mm	.167" / 4.24 mm
Brake Disc Thickness Variance Between Measurements	--	.002" / .051 mm
Brake Disc Runout	--	.010" / .254 mm
Caliper Piston Diameter	1.250" / 31.75 mm	1.246" / 31.65 mm
Caliper Bore Diameter	1.254" / 31.85 mm	1.256" / 31.90 mm

General Torque Specifications**TORQUE SPECIFICATIONS**

Item	Torque ft. lbs. (in. lbs.)	Torque (Nm)
Caliper Mounting Bolts	37	50
Handlebar Master Cylinder Clamp Bolts	(70 in. lbs.)	7-9
Hand Master Cylinder Reservoir Cover	(7 in. lbs.)	0.8
Brake Line Flare Fitting	12 - 15	16 - 20
Brake Line Banjo Bolt Fitting	15	20
Bleeder Screw	(47 in. lbs.)	5.3

Special Tools / Brake Fluid**SPECIAL TOOLS**

Part Number	Tool Description
2870975	Mity Vac™
2872189	DOT 4 Brake Fluid

BRAKE SYSTEM SERVICE NOTES

Disc brake systems are light weight, low maintenance, and perform well in the conditions this vehicle will routinely encounter. There are a few things to remember when replacing disc brake pads or performing brake system service to ensure proper system function and maximum pad service life.

- Do not over-fill the master cylinder fluid reservoir(s).
- Make sure the brake lever / pedal returns freely and completely.
- Adjust stop pin on calipers after pad service.
- Check and adjust master cylinder reservoir fluid level after pad service.
- Make sure atmospheric vent on reservoir is unobstructed.
- Test for brake drag after any brake system service and investigate cause if brake drag is evident.
- Make sure caliper moves freely on guide pins (where applicable).
- Inspect caliper piston seals for foreign material that could prevent caliper pistons from returning freely.
- Perform a brake burnishing procedure after installing new pads to maximize service life.
- DO NOT lubricate or clean the brake components with aerosol or petroleum products. Use only approved brake cleaning products.
- DO NOT allow brake cleaning products to contact painted surfaces. Paint damage will occur as a result.

BRAKE NOISE TROUBLESHOOTING

Dirt or dust buildup on the brake pads and disc is the most common cause of brake noise (squeal caused by vibration). If cleaning does not reduce the occurrence of brake noise, Permatex™ *Disc Brake Quiet* can be applied to the back of the pads. Follow directions on the package. This will keep pads in contact with caliper piston(s) to reduce the chance of squeaks caused by dirt or dust.

Brake Noise Troubleshooting	
Possible Cause	Remedy
Dirt, dust, or imbedded material on pads or disc	Spray disc and pads with CRC Brakeleen™ or an equivalent non-flammable aerosol brake cleaner. Remove pads and/or disc hub to clean imbedded material from disc or pads.
Pad(s) dragging on disc (noise or premature pad wear) because of improper adjustment Master cylinder reservoir overfilled Master cylinder compensating port restricted Master cylinder piston not returning completely Caliper piston not returning Operator error (riding the brake)	Adjust pad stop Set to proper level Clean compensating port Clean, inspect, and repair as necessary Clean piston seals and inspect the seal grooves Educate operator
Loose wheel hub or bearings	Check wheel and hub for abnormal movement (see Chapter 8).
Brake disc warped or excessively worn	Replace disc
Brake disc misaligned or loose	Inspect and repair as necessary
Noise is from other source (axle, hub, disc or wheel)	If noise does not change when brake is applied check other sources. Inspect and repair as necessary

BRAKES

HYDRAULIC BRAKE SYSTEM OPERATION

The brake system consists of the following components or assemblies: hand brake master cylinder w/lever, foot brake master cylinder w/pedal, brake fluid reservoirs, brake lines, brake calipers, brake pads, and brake discs, which are secured to the drive line.

When the brake lever or pedal is applied, it moves the hydraulic piston within the master cylinder. As the master cylinder piston moves inward it closes a small opening (compensating port) within the cylinder and starts to build pressure within the brake system. As the pressure within the system is increased, the pistons located in the brake calipers move outward and apply pressure to the moveable brake pads. These pads contact the brake discs and move the calipers in their floating bracket, pulling the stationary side pads into the brake discs. The resulting friction reduces brake disc and vehicle speed.

The friction applied to the brake pads will cause the pads to wear. As these pads wear, the piston within the caliper moves further outward and becomes self adjusting. Fluid from the reservoir fills the additional area created when the caliper piston moves outward.

Brake fluid level is critical to proper system operation. Too little fluid will allow air to enter the system and cause the brakes to feel spongy. Too much fluid could cause brakes to drag due to fluid expansion.

Located within the master cylinder is the compensating port which is opened and closed by the master cylinder piston assembly. As the temperature within the hydraulic system changes, this port compensates for fluid expansion or contraction. Due to the high temperatures created within the system during heavy braking, it is very important that the master cylinder reservoir have adequate space to allow for fluid expansion. **Never overfill the reservoir! Do not fill the reservoir beyond the MAX LEVEL line!**

When servicing Polaris brake systems use only **Polaris DOT 4 Brake Fluid (PN 2872189)**. **WARNING:** Once a bottle is opened, use what is necessary and discard the rest in accordance with local laws. Do not store or use a partial bottle of brake fluid. Brake fluid is hygroscopic, meaning it rapidly absorbs moisture. This causes the boiling temperature of the brake fluid to drop, which can lead to early brake fade and the possibility of serious injury.

BRAKE SYSTEM EXPLODED VIEW

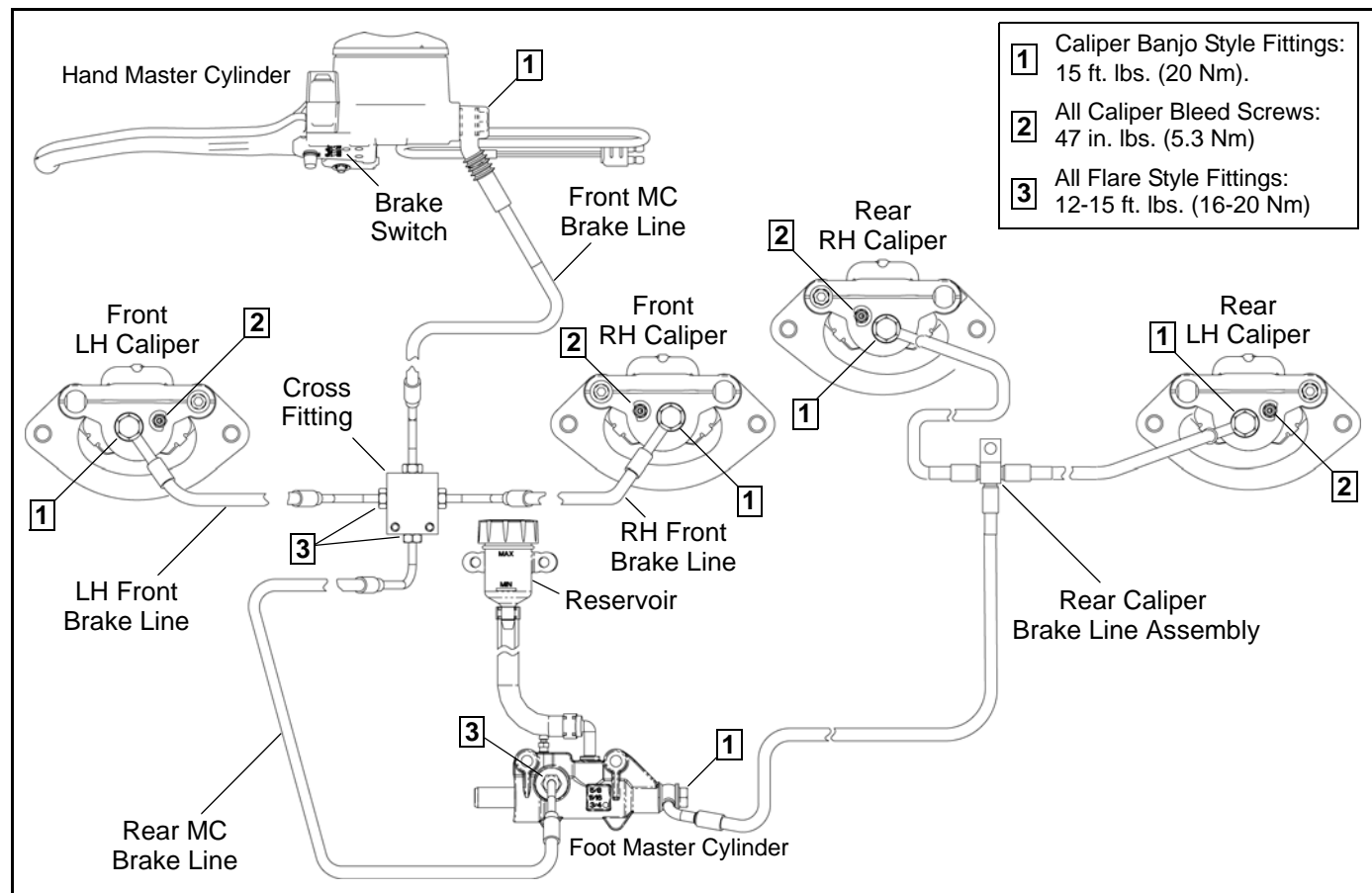

Brake Caliper Exploded View

Apply Polaris DOT 4 Brake Fluid to Component

Apply Polaris All Purpose Grease

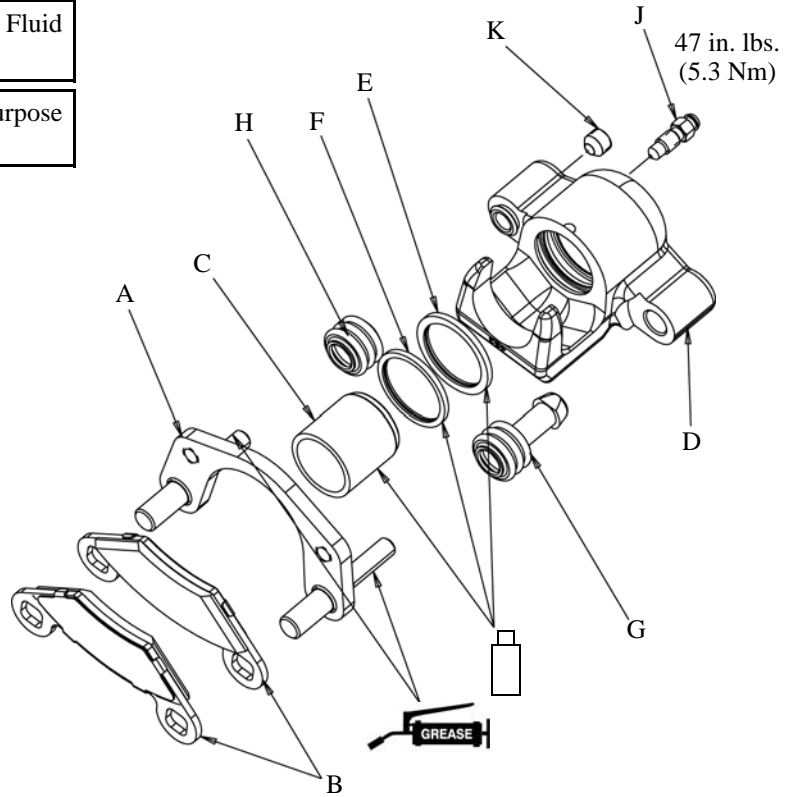

- A. Caliper Mount
- B. Brake Pads
- C. Piston
- D. Caliper Assy.
- E. Square O-ring (thick)
- F. Square O-ring (thin)
- G. Boot, Pin Bushing
- H. Boot, Pin Seal
- J. Bleeder Screw
- K. Adjustment Set Screw

Hand Master Cylinder Exploded View

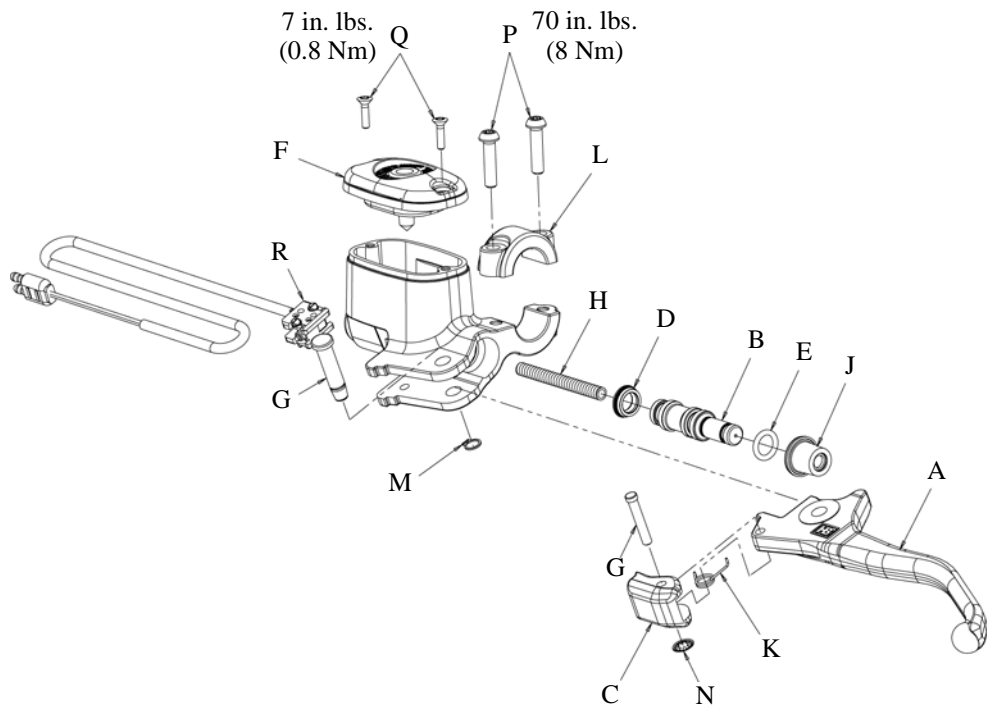

- A. Lever
- B. Piston
- C. Locking Lever
- D. Primary Cup
- E. O-ring
- F. Reservoir Cover
- G. Pivot Pin
- H. Piston Return Spring
- J. Dust Boot
- K. Lever Return Spring
- L. Clamp
- M. Retaining Ring
- N. Locking Push On
- P. Torx Screws
- Q. Cover Screws
- R. Brake Switch

BRAKES

BRAKE BLEEDING

Fluid Replacement

NOTE: When bleeding the brakes or replacing the fluid, always start with the caliper farthest from the master cylinder.

⚠ CAUTION

Always wear safety glasses during these procedures.
 Brake fluid will damage finished surfaces.
 Do not allow brake fluid to come in contact with finished surfaces.

This procedure should be used to change fluid or bleed brakes during regular maintenance.

1. Clean reservoir cover thoroughly.
2. Remove screws, cover and diaphragm from master cylinder reservoir.

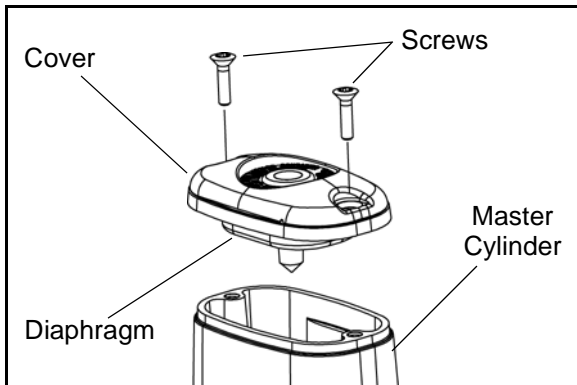

3. Inspect vent slots in cover and remove any debris or blockage.
4. If changing fluid, remove old fluid from reservoir and lines at the bleeders with a Mity Vac™ or similar tool.

NOTE: Do not move brake lever when reservoir fluid level is low.

5. Add brake fluid to .25" - .30" (6 - 8 mm) from the top of the reservoir.

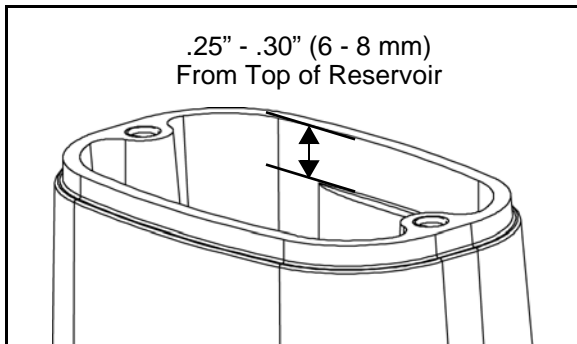

Polaris DOT 4 Brake Fluid
PN: 2872189

Bleeding Procedure

Front Brake System Bleeding

1. Remove the reservoir cover from the hand brake master cylinder and verify fluid is at specified level.
2. If fluid level is low, add brake fluid to .25" - .30" (6 - 8 mm) from the top of the reservoir.
3. Install a box end wrench on foot master cylinder bleeder screw. Attach a clean, clear hose to fitting and place the other end in a container. Be sure the hose fits tightly on fitting.

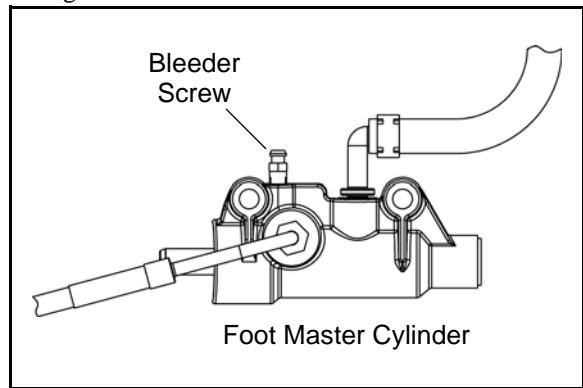

NOTE: Install diaphragm and cover onto the hand master cylinder reservoir to prevent spills. Do not tighten the cover.

4. Slowly pump the hand brake lever until pressure builds and holds.
5. While maintaining lever pressure, open bleeder screw.
6. Close bleeder screw and release brake lever

NOTE: Do not release lever before bleeder screw is tight or air may be drawn into caliper.

7. Repeat procedure until clean fluid appears in bleeder hose and all air has been purged. Add fluid as necessary to maintain level in reservoir.

⚠ CAUTION

Maintain at least 1/2" (1.27 cm) of brake fluid in the reservoir to prevent air from entering the master cylinder.

8. Tighten bleeder screw securely and remove bleeder hose. Torque the bleeder screw to **47 in. lbs. (5.3 Nm)**.

9. Repeat the procedure on the two remaining front calipers.
10. Add DOT 4 brake fluid to .25" - .30" (6 - 8 mm) from the top of the reservoir.
11. Install diaphragm, cover and screws. Torque the screws to 7 in. lbs. (0.8 Nm).

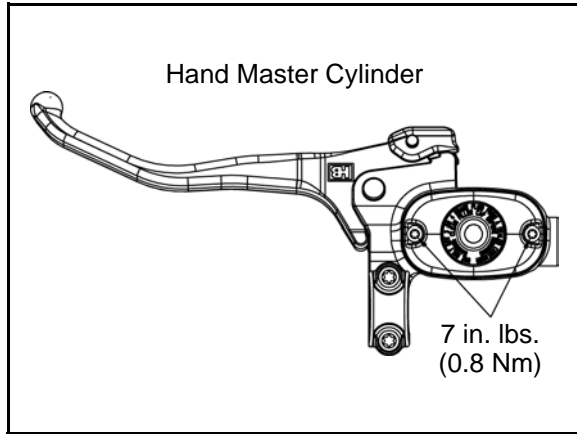

12. Proceed to "Rear Brake System Bleeding" to complete bleeding procedure.

Rear Brake System Bleeding

Remove the front rack and locate the foot brake fluid reservoir for the foot master cylinder (see the following illustration).

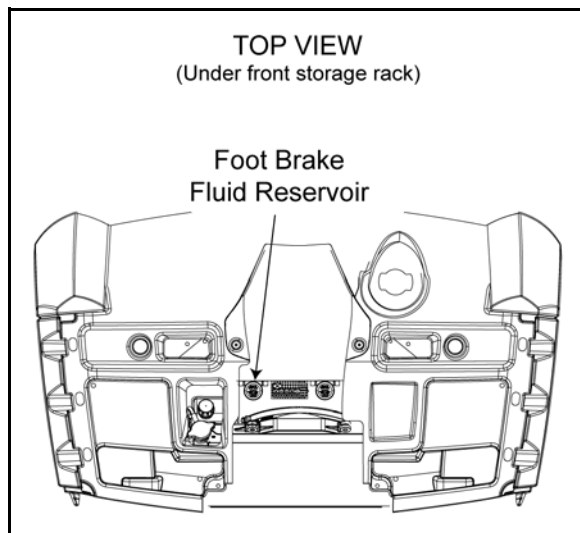

1. Thoroughly clean the fluid reservoir cover before removal.
2. Remove the cap and diaphragm from the reservoir and verify fluid level is at the MAX level mark.
3. If changing fluid, remove old fluid from reservoir with a Mity Vac™ (PN 2870975) or similar tool.

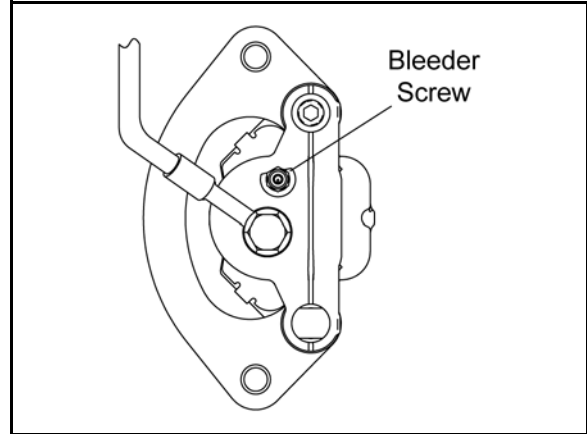

4. Using a funnel, add brake fluid to the MAX level mark on the reservoir.
5. Install a box end wrench on the rear caliper bleeder screw. Attach a clean, clear hose to fitting and place the other end in a container. Be sure the hose fits tightly on fitting.
6. Slowly pump the foot brake pedal until pressure builds and holds.
7. While maintaining pedal pressure, open bleeder screw.
8. Close bleeder screw and release brake pedal.

NOTE: Do not release pedal before bleeder screw is tight or air may be drawn into caliper.

9. Repeat procedure until clean fluid appears in bleeder hose and all air has been purged. Add fluid as necessary to maintain level in reservoir.
10. Tighten bleeder screw securely and remove bleeder hose. Torque the bleeder screw to **47 in. lbs. (5.3 Nm)**.
11. Repeat the procedure on the remaining rear caliper.
12. Using a funnel, add brake fluid to the MAX level mark on the reservoir.
13. Field test machine at low speed before putting into service. Check for proper braking action and lever reserve. With lever firmly applied, lever reserve should be no less than 1/2", (1.3 cm) from handlebar.
14. Check brake system for fluid leaks and inspect all hoses and lines for wear or abrasion. Replace hose if wear or abrasion is found.

BRAKES

HAND BRAKE MASTER CYLINDER

Removal

1. Clean master cylinder and reservoir assembly. Make sure you have a clean work area to disassemble brake components.
2. Place a shop towel or suitable catch container under the master cylinder brake line connection. Remove the banjo bolt fitting that connects the brake line to the master cylinder. Discard the sealing washers.

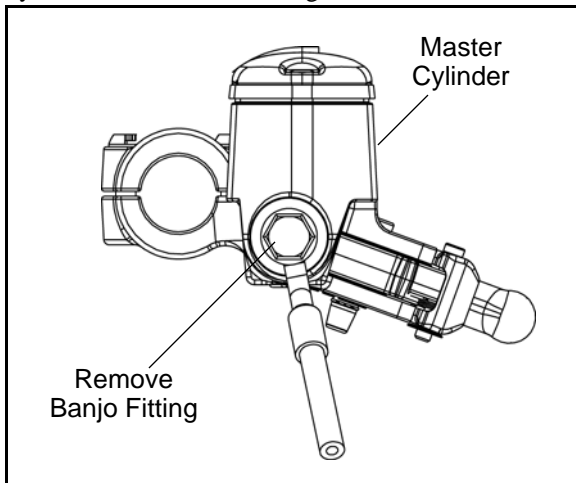

CAUTION

Brake fluid will damage finished surfaces.
Do not allow brake fluid to come in contact with finished surfaces.

3. Remove the Torx screws from the master cylinder clamp.
4. Hold master cylinder upright and lift the master cylinder from the handlebars. Cover brake line orifice to avoid spilling fluid.

Disassembly

The hand master cylinder is a serviceable component. Polaris offers a number of service kits to rebuild this style of master cylinder. Refer to the Polaris Electronic Parts Catalog.

Installation

NOTE: Use only OEM parts that were designed for the model ATV being serviced. There are different hand master cylinders for the different Polaris ATV models. Refer to the Electronic Parts Catalog.

NOTE: Some master cylinders are not serviceable and are replaced only as an assembly.

1. Install master cylinder on handlebars. Torque bolt furthest from the reservoir first, followed by the bolt closest to the reservoir. Torque clamp bolts to **70 in. lbs. (8 Nm)**.

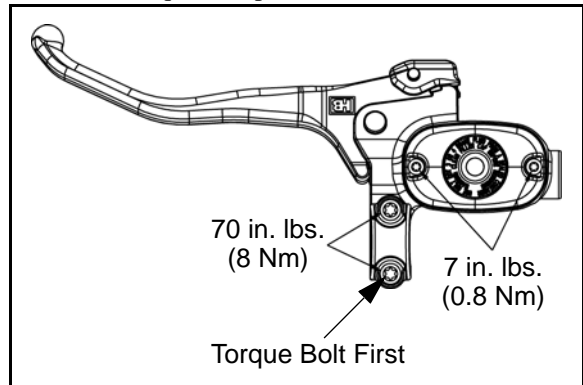

NOTE: Speed up brake bleeding by purging air before brake line is attached. Fill with DOT 4 Brake Fluid and pump lever slowly 2 to 3 times with finger over the outlet end to purge master cylinder of air.

2. Place new sealing washers on each side of banjo line and torque banjo bolt to specification.



Brake Line Banjo Bolt:
15 ft. lbs. (20 Nm)

3. Fill reservoir with DOT 4 brake fluid (PN 2872189).
4. Follow brake bleeding procedures. Check all connections for leaks and repair if necessary.

Brake Switch Replacement

1. Set the parking brake lock and locate the brake switch behind the hand brake lever.
2. Using a small screwdriver or similar tool, push up on the mounting tabs through the holes on the bottom side while rotating the switch to disengage the tabs from the holes.

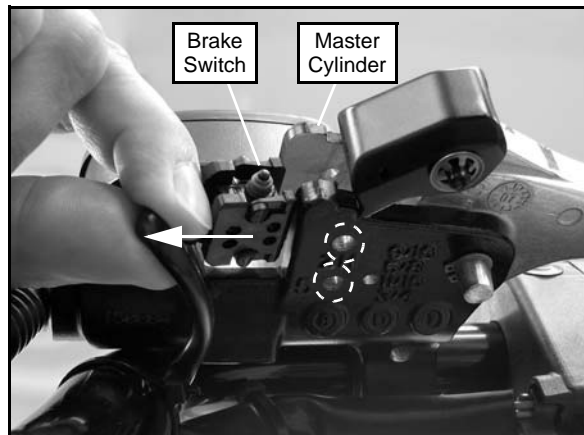

3. Install the new switch. The tabs should snap in place.

FOOT BRAKE MASTER CYLINDER

Operation Overview

When the brake pedal is applied it contacts the piston of the foot brake master cylinder. As the pressure within the system is increased, the pistons located in the rear brake calipers move outward and apply equal pressure to the brake pads.

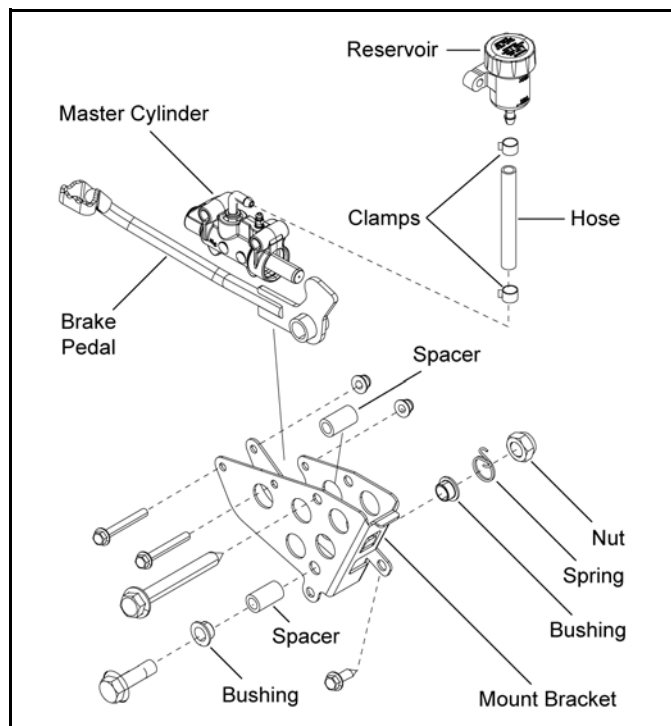

Foot Master Cylinder Removal / Installation

1. Remove the RH mud guard and footwell (see Chapter 9).
2. Remove the front and rear brake line from the master cylinder. Use a suitable container to catch the brake fluid. Dispose of brake fluid properly.

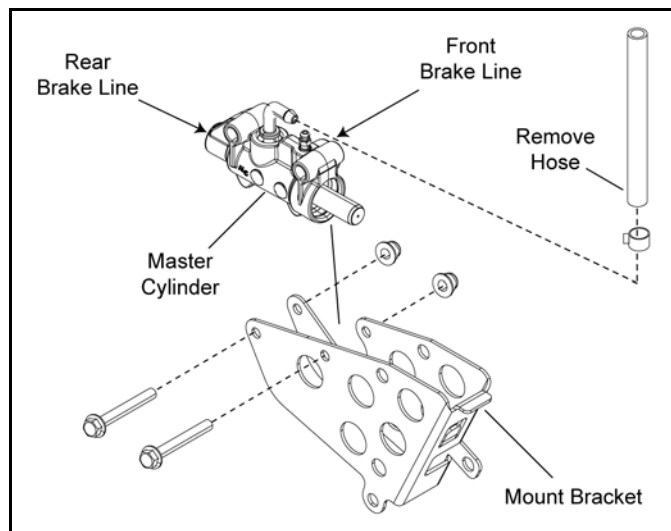

3. Remove the (2) through-bolts retaining the master cylinder to the mount bracket. Replace components as needed.
4. Reverse this procedure when reinstalling and torque mounting fasteners to specification.

 = T
Master Cylinder Mounting Fasteners: 8 ft. lbs. (11 Nm)

5. Reinstall the brake line and torque the banjo bolt (with new sealing washers installed) to specification.

 = T
Brake Line Banjo Bolts: 15 ft. lbs. (20 Nm)

6. Bleed the master cylinder following the procedure outlined in the "Brake Bleeding" section of this chapter.

Brake Pedal Removal / Installation

1. Remove the RH mud guard and footwell (see Chapter 9).
2. Remove the through-bolt retaining the brake pedal to the mount bracket.
3. Remove the bolt, bushings, spacer, spring and brake lever.

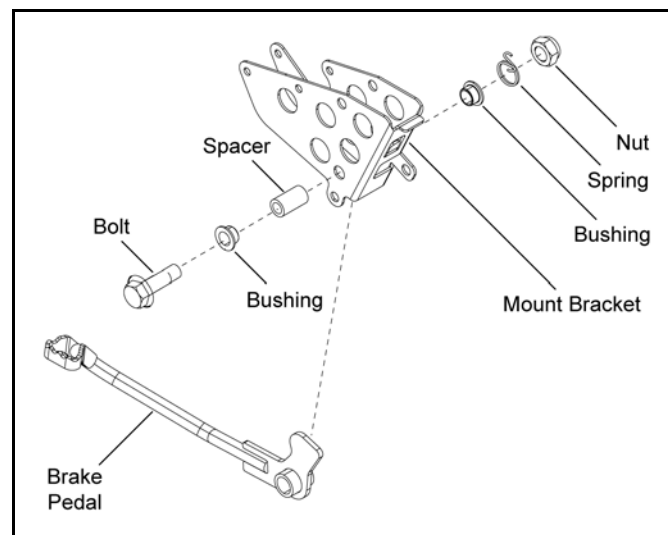

4. Inspect and replace components as needed.
5. Reverse this procedure when reinstalling and torque mounting fastener to specification.

 = T
Brake Pedal Mounting Fastener: 38 ft. lbs. (52 Nm)

BRAKES

BRAKE PADS

Pad Removal

1. Loosen the (4) wheel nuts.
2. Elevate and support the side of the ATV in which the caliper brake pads are being serviced.

⚠ CAUTION

Use care when supporting vehicle so that it does not tip or fall. Severe injury may occur if machine tips or falls.

3. Remove the wheel nuts and wheel.
4. Remove the (2) brake caliper mounting bolts and caliper.

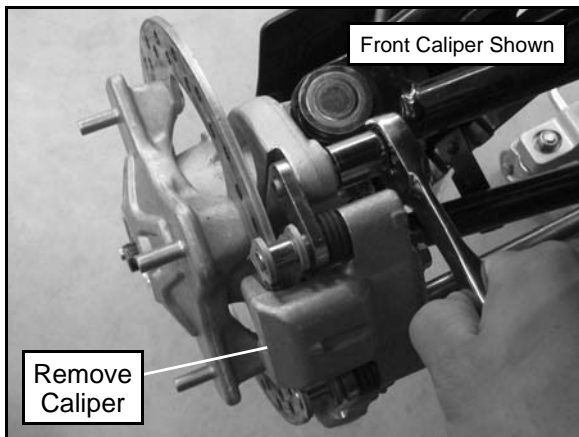

5. Push mounting bracket inward and slip the outer brake pad past the edge of the pin. Remove the inner brake pad.



Pad Inspection

1. Measure the thickness of the pad material. Replace pads if worn beyond the service limit.

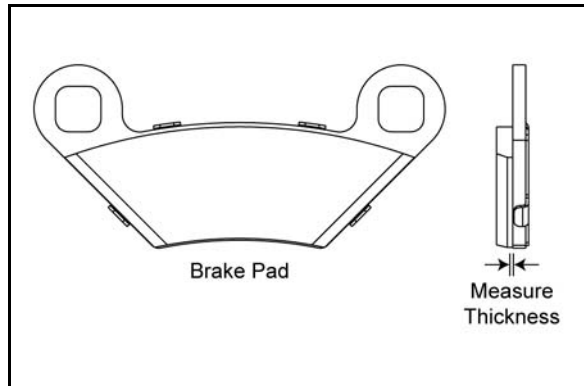

= In. / mm.

Brake Pad Material Thickness
Service Limit: .040" (1 mm)

Pad Installation

1. Lubricate mounting bracket pins and external slide pin O-ring with a light film of Polaris Premium All Season Grease (PN 2871423).

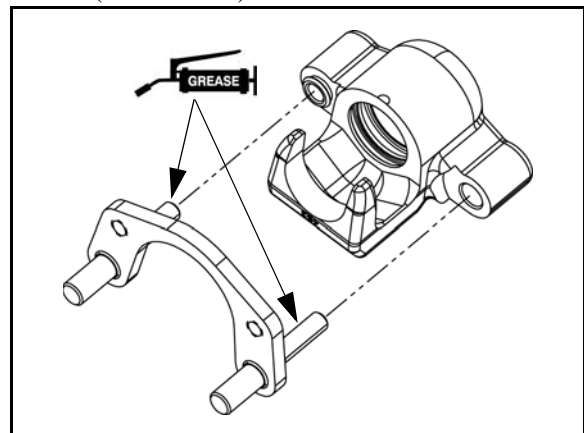

2. Compress mounting bracket. Install pads with friction material facing each other.

⚠ WARNING

If the brake pads are contaminated with grease, oil, or liquid soaked do not use the pads. Use only new clean brake pads.

3. Install the caliper and torque new mounting bolts to specification.

⚠ CAUTION

New bolts have a pre-applied locking agent which is destroyed upon removal. Always use new brake caliper mounting bolts upon assembly.

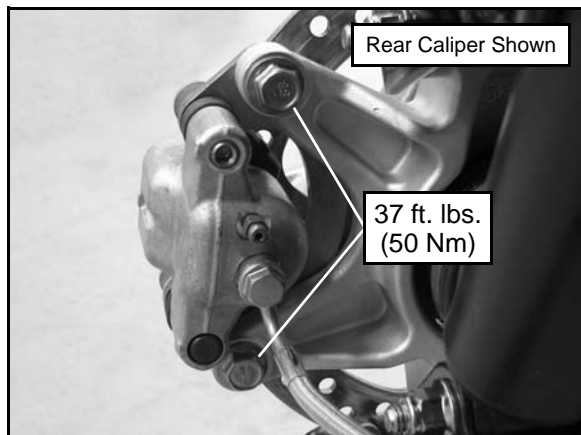

4. Slowly pump the brake lever/pedal until pressure has been built up. Maintain at least 1/2, (12.7 mm) of brake fluid in the reservoir to prevent air from entering the brake system.
5. Verify fluid level in reservoir is at specified level inside reservoir and install reservoir cap.
6. Install the wheel(s) and wheel nuts. Torque wheel nuts to specification.

⚙ = T

Wheel Nuts:
Steel Wheels: 45 ft. lbs. (61 Nm)
Aluminum Wheels: 75 ft. lbs. (102 Nm)

Brake Burnishing Procedure

It is required that a burnishing procedure be performed after installation of new brake pads to extend service life and reduce noise.

Start machine and slowly increase speed to 30 mph. Gradually apply brakes to stop machine. Allow pads and disc to cool sufficiently during the procedure. Do not allow pads or disc to become hot or warping may result. Repeat this procedure 10 times.

CALIPER SERVICE

Caliper Removal

1. Loosen the (4) wheel nuts.
2. Elevate and support the side of the ATV in which the caliper is being serviced.

⚠ CAUTION

Use care when supporting vehicle so that it does not tip or fall. Severe injury may occur if machine tips or falls.

3. Remove the wheel nuts and wheel.
4. Place a suitable container under the caliper to catch brake fluid draining from brake line. Using a wrench, loosen and remove brake line from the caliper.

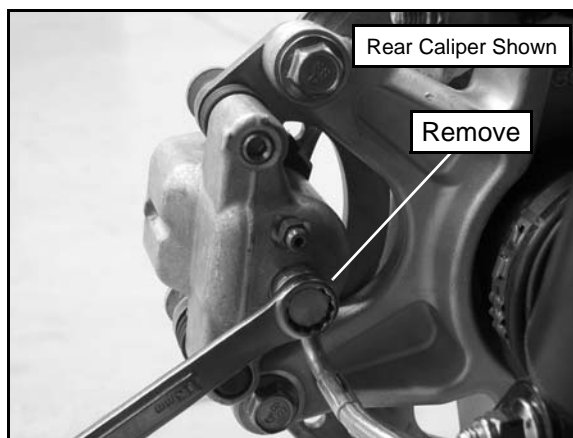

5. Remove (2) caliper mounting bolts and remove the caliper assembly from the bearing carrier.

Caliper Disassembly

1. Push mounting bracket inward and slip the outer brake pad past the edge of the pin. Remove the inner brake pad.

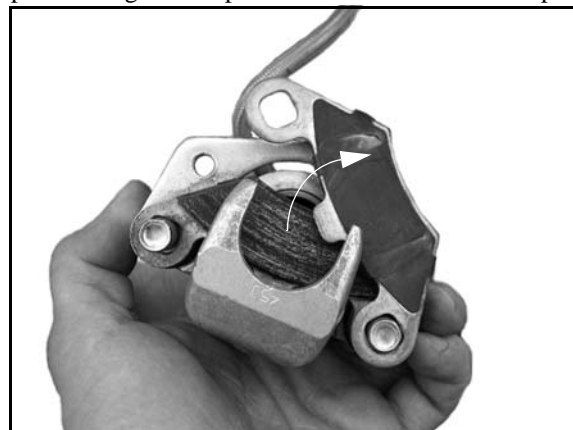

BRAKES

- Remove mounting bracket, pin assembly and dust boot.

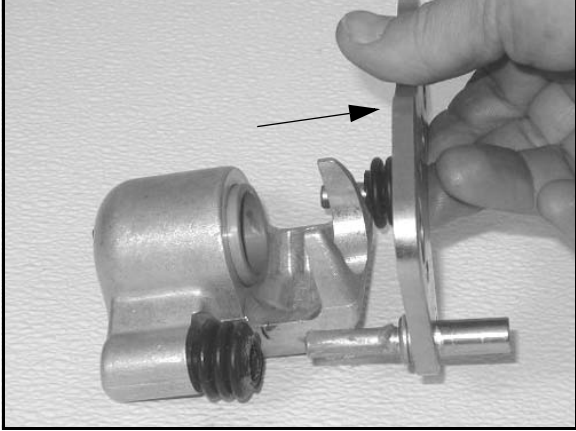

- Using a hammer and a small punch, remove the piston from the caliper body, then remove the square O-rings (see "BRAKE CALIPER - Exploded View").

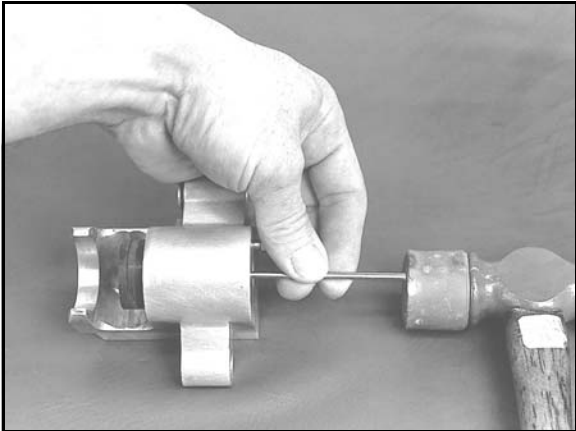

- Clean the caliper body, piston, and mounting bracket with brake cleaner or denatured alcohol.

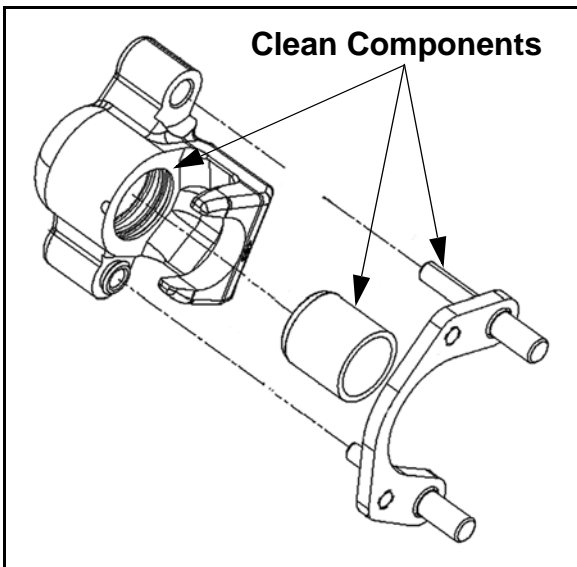

NOTE: Be sure to thoroughly clean the seal grooves in the caliper body.

Caliper Inspection

- Inspect caliper body for nicks, scratches or wear. Measure bore size and compare to specifications. Replace if damage is evident or if worn beyond service limit.

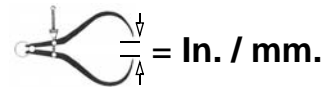

Front Calipers:

Caliper Bore I.D.

Std: 1.192" (30.28 mm)

Service Limit: 1.194" (30.33 mm)

Rear Calipers:

Caliper Bore I.D.

Std: 1.254" (31.85 mm)

Service Limit: 1.256" (31.90 mm)

- Inspect piston for nicks, scratches, wear or damage. Measure diameter and replace if damaged or worn beyond service limit.



- Inspect the brake pad and disc as outlined in this chapter (see "Pad Inspection" and "Brake Disc Inspection").

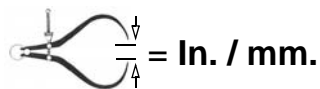

Front Calipers:
Caliper Piston O.D.
 Std: 1.186" (30.12 mm)
 Service Limit: 1.184" (30.07 mm)

Rear Calipers:
Caliper Piston O.D.
 Std: 1.250" (31.75 mm)
 Service Limit: 1.246" (31.65 mm)

4. Compress the mounting bracket and make sure the dust seals are fully seated.
5. Install the brake pads.
6. Clean the disc and pads with brake parts cleaner or denatured alcohol to remove any dirt, oil or grease.

Caliper Installation

1. Install caliper assembly over the brake disc and onto the bearing carrier. Torque mounting bolts to specification.

CAUTION

New bolts have a pre-applied locking agent which is destroyed upon removal. Always use new brake caliper mounting bolts upon assembly.

Caliper Reassembly

1. Install new O-rings (A) in the caliper body (B). Be sure grooves are clean or brakes may drag upon assembly.

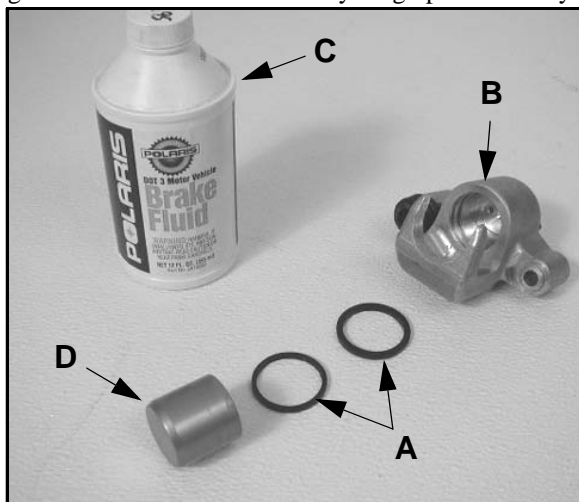

2. Coat piston with DOT 4 Brake Fluid (C). Install piston (D) with a twisting motion while pushing inward. Piston should slide in and out of the bore smoothly, with light resistance.
3. Lubricate the mounting bracket pins with Polaris Premium All Season Grease (PN 2871423), and install the rubber dust seal boots.

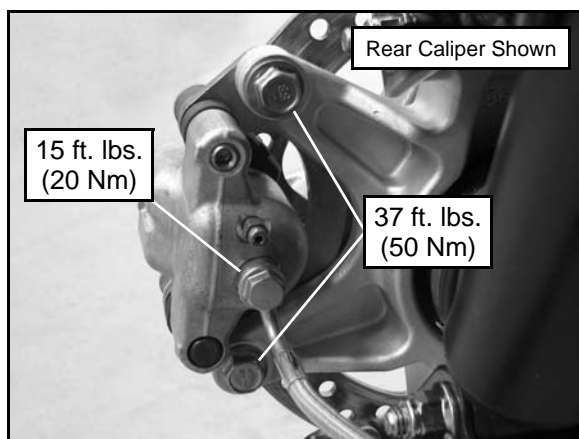
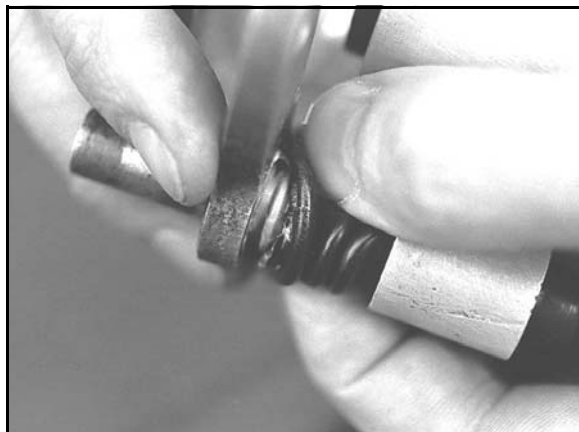

2. Install brake line and torque the banjo bolt fitting to specification.
3. Perform brake bleeding procedure as outlined earlier in this chapter.
4. Install the wheel and (4) wheel nuts. Torque wheel nuts to specification.

= T

Wheel Nuts:
Steel Wheels: 45 ft. lbs. (61 Nm)
Aluminum Wheels: 75 ft. lbs. (102 Nm)

BRAKES

BRAKE DISC SERVICE

Disc Inspection

1. Visually inspect the brake disc for scoring, scratches, or gouges. Replace the disc if any deep gouges are evident.

Measure the disc thickness at 8 different points around the pad contact surface using a 0–1” micrometer. Replace disc if worn beyond service limit.

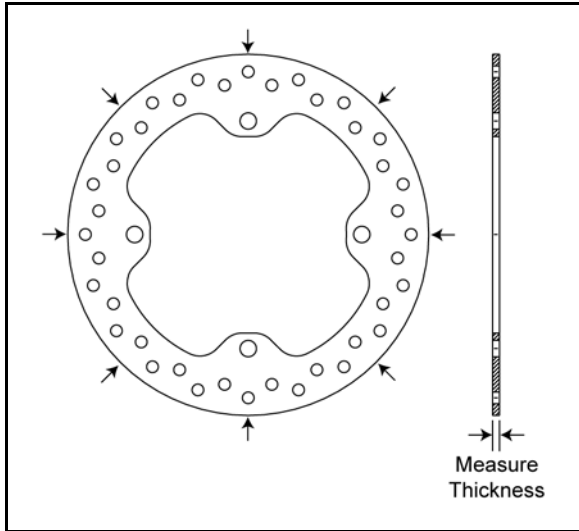

Brake Disc Thickness
 New: .187" (4.75 mm)
 Service Limit: .167" (4.24 mm)

Brake Disc Thickness Variance
 Service Limit: .002" (.051 mm)
 (difference between measurements)

2. Mount a dial indicator as shown and measure disc runout. Slowly rotate the disc and read total runout on the dial indicator. Replace the disc if runout exceeds specification.

Brake Disc Runout
 Service Limit: .010" (.254 mm)

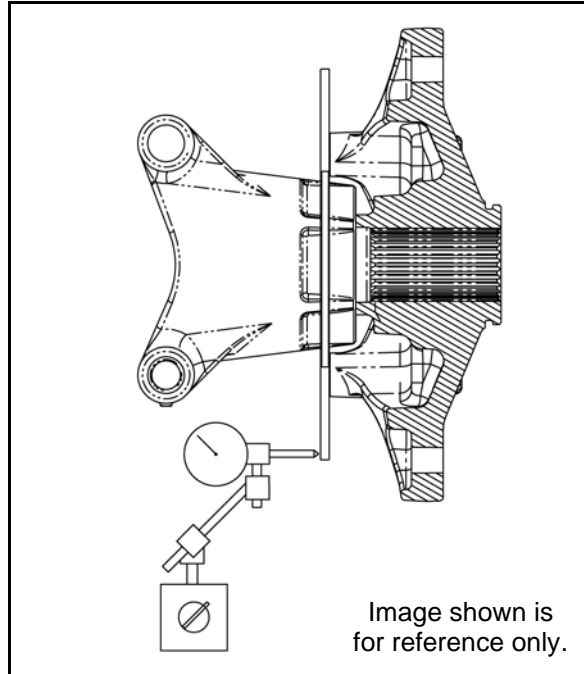

Disc Removal / Replacement

1. Loosen the (4) wheel nuts.
2. Elevate and support the side of the ATV in which the brake disc is being serviced.

CAUTION

Use care when supporting vehicle so that it does not tip or fall. Severe injury may occur if machine tips or falls.

3. Remove the wheel nuts and wheel.
4. Remove the cotter pin, castle nut and cone washers.

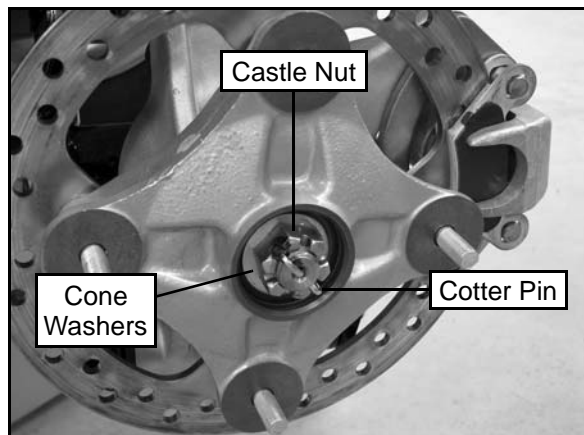

- Remove the two brake caliper mounting bolts.
CAUTION: Do not hang the caliper by the brake line. Use wire to hang caliper to prevent damage to the brake line.

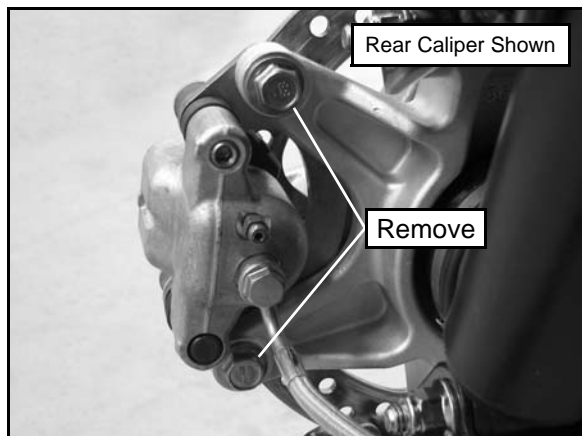

- Remove the wheel hub assembly from the bearing carrier.
- Press out the wheel studs and remove the brake disc.

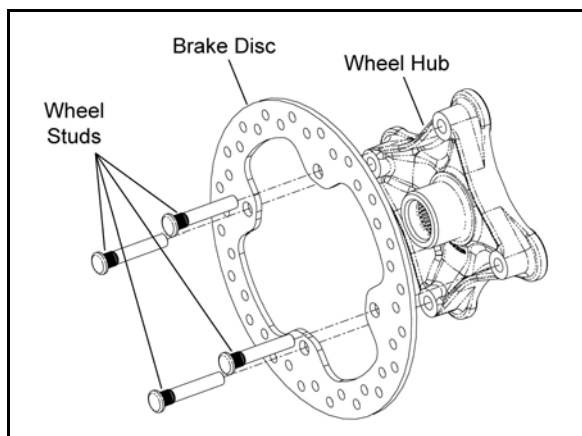

- Clean the wheel hub mating surface
- Install the new disc and press new wheel studs into the hub until they are flush with the mating surface.

⚠ CAUTION

Always use new wheel studs if removed from the wheel hub assembly.

- Install wheel hub assembly, cone washers, and hand tighten the castle nut. Install washers with domed side out.

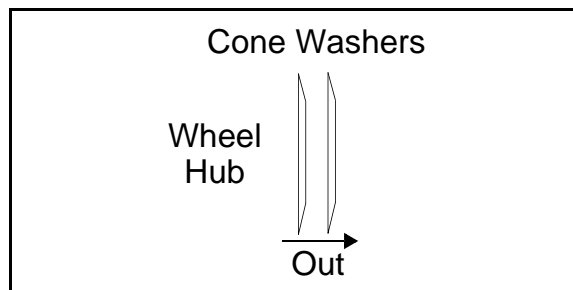

- Install the brake caliper and torque the new mounting bolts to specification.

⚠ CAUTION

New bolts have a pre-applied locking agent which is destroyed upon removal. Always use new brake caliper mounting bolts upon assembly.

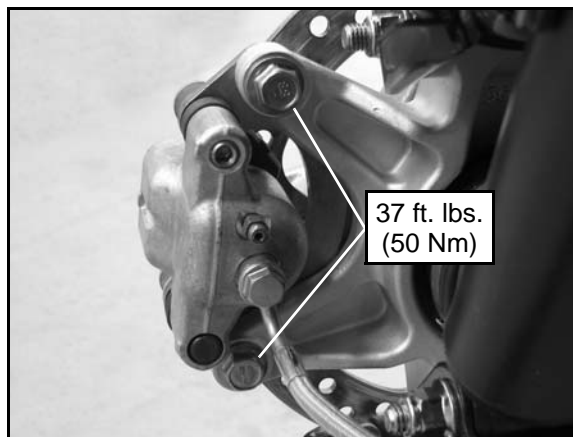

⚙ = T

Caliper Mounting Bolts:
37 ft. lbs. (50 Nm)

BRAKES

12. Torque wheel hub nut to specification and install a new cotter pin. Tighten nut slightly if necessary to align cotter pin holes.

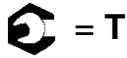
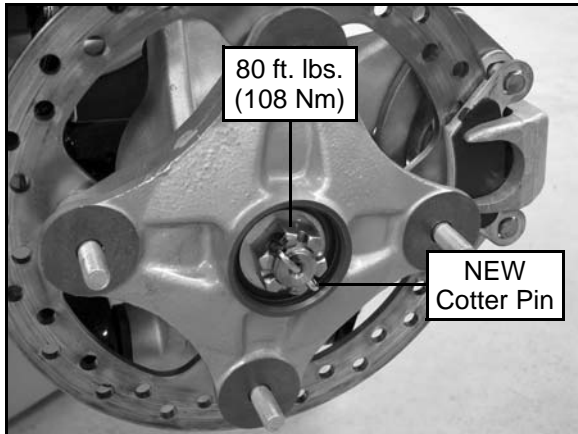

Wheel Hub Castle Nut:
80 ft. lbs. (108 Nm)

13. Install the wheel and (4) wheel nuts. Torque wheel nuts to specification.

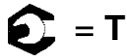

Wheel Nuts:
Steel Wheels: 45 ft. lbs. (61 Nm)
Aluminum Wheels: 75 ft. lbs. (102 Nm)

14. Field test the ATV for proper braking action before putting into service. Inspect for fluid leaks and firm brakes. Make sure the brake is not dragging when lever is released. If the brake drags, re-check assembly and installation.

TROUBLESHOOTING

Brake Squeal

- Dirty/contaminated friction pads
- Improper alignment
- Worn disc
- Worn caliper
- Glazed brake pads

Poor Brake Performance

- Air in system
- Water in system (brake fluid contaminated)
- Caliper/disc misaligned
- Caliper dirty or damaged
- Brake line damaged or lining ruptured
- Worn disc and/or friction pads
- Incorrectly adjusted stationary pad
- Worn or damaged master cylinder or components

Lever / Pedal Vibration

- Disc damaged
- Disc worn / warped (runout or thickness variance exceeds service limit)

Caliper Overheats (Brakes Drag)

- Compensating port plugged
- Brake lever or pedal binding or unable to return fully
- Parking brake left on
- Residue build up under caliper seals
- Operator riding brakes

Brakes Lock

- Alignment of caliper to disc
- Reservoir is overfilled with fluid
- Master cylinder compensating port plugged
- Caliper piston is stuck
- Parking brake left on

WIRE DIAGRAM

2009 SPORTSMAN XP 850 (PAGE 2 OF 2)

Table with 5 columns: CWT #, COLOR, MM SQ, FROM CONNECTOR, WIRE TERMINATION TABLE, TO CONNECTOR, CAVITY, FUNCTION. Contains detailed wiring information for various components.

Table with 5 columns: CWT #, COLOR, MM SQ, FROM CONNECTOR, WIRE TERMINATION TABLE, TO CONNECTOR, CAVITY, FUNCTION. Contains detailed wiring information for various components.

WIRE IDENTIFIER PREFIXES, MANUFACTURER, PART NO., DESCRIPTION, CONNECTIONS, and ABBREVIATIONS tables.

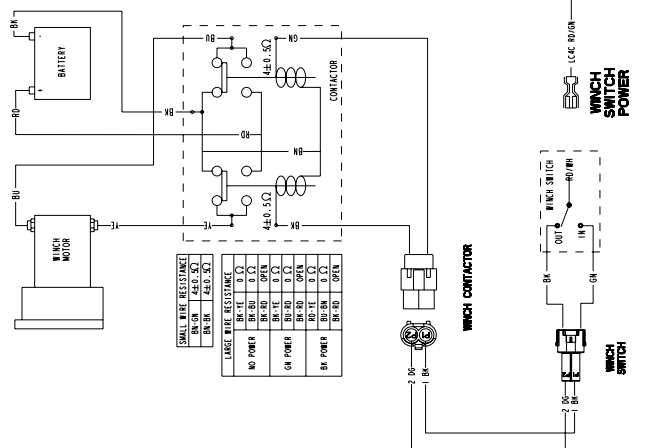
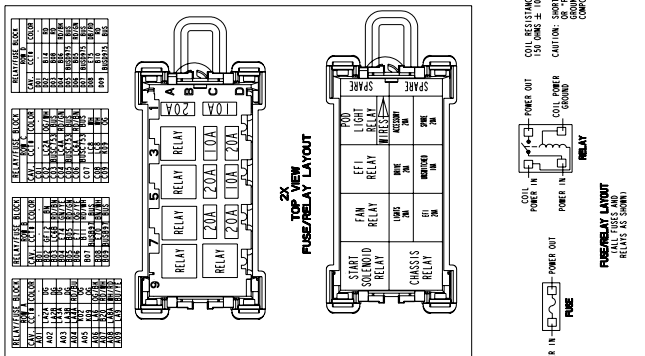

2009 SPORTSMAN XP 850 (AWD / ADC)

2009 SPORTSMAN XP 850 - AWD/ADC
 D6G 20080821A

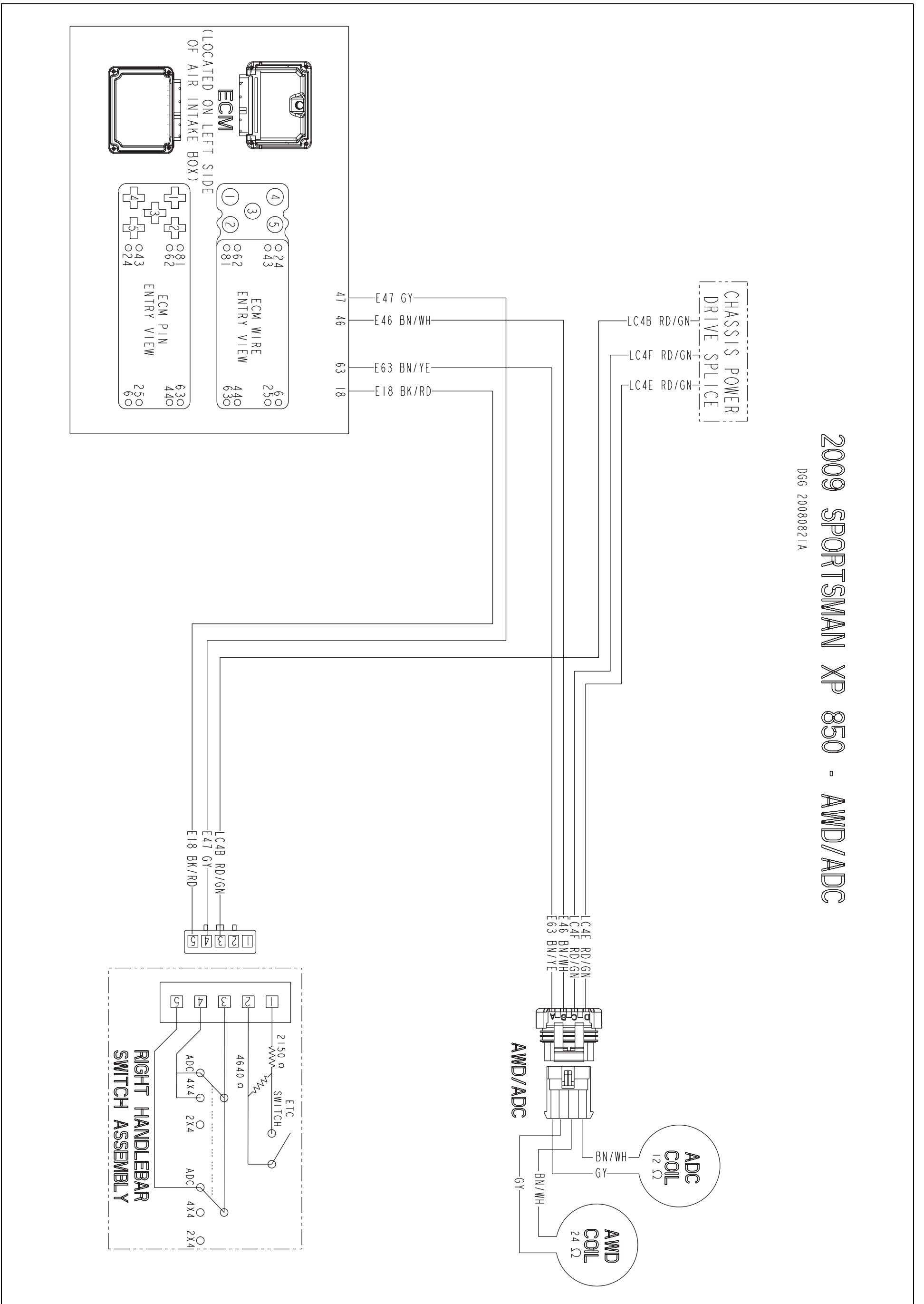

2009 SPORTSMAN XP 850 (BATTERY CHARGING)

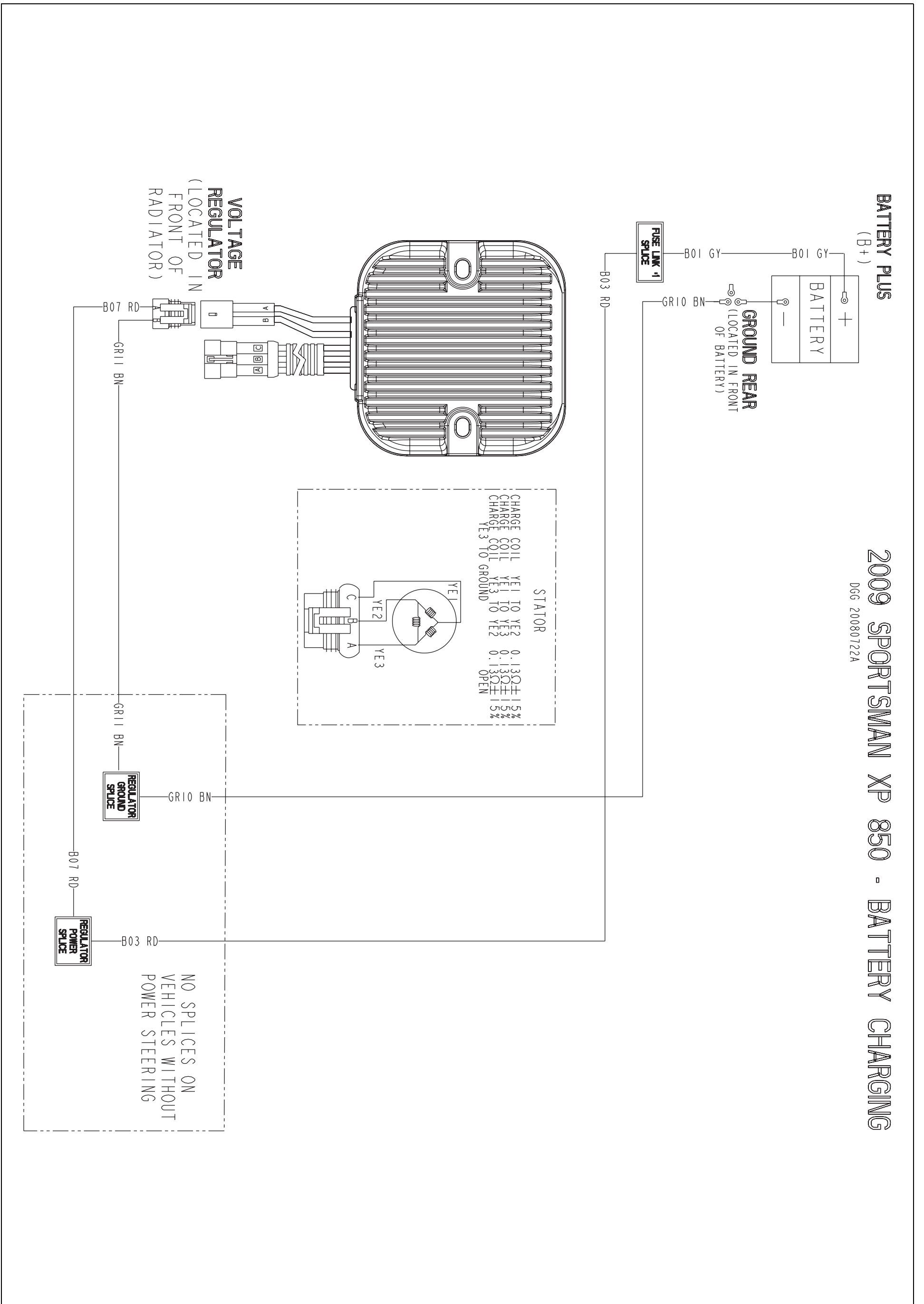

2009 SPORTSMAN XP 850 (BATTERY PLUS)

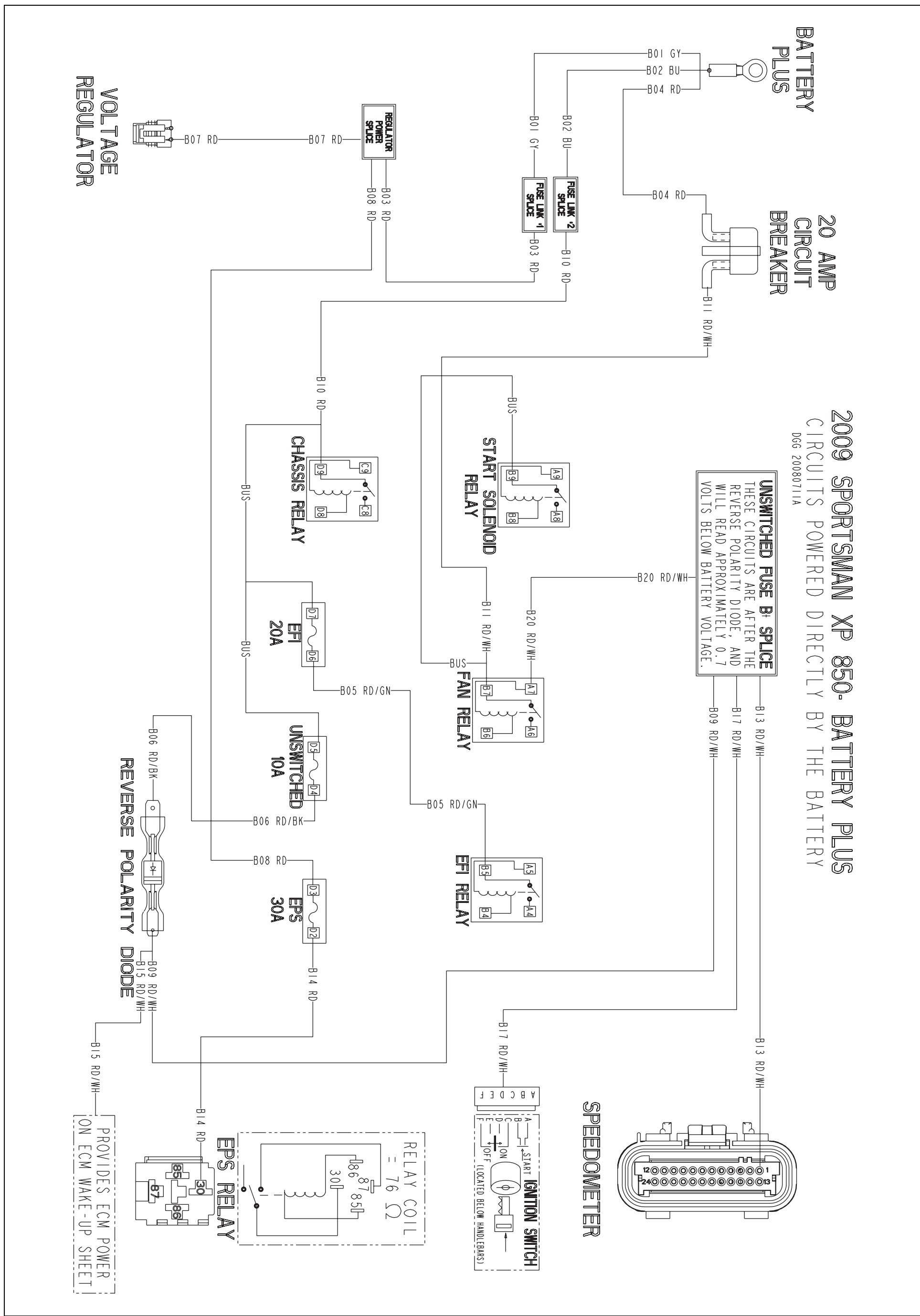

2009 SPORTSMAN XP 850- BATTERY PLUS
 CIRCUITS POWERED DIRECTLY BY THE BATTERY
 D66 20080711A

2009 SPORTSMAN XP 850 (BRAKE LAMPS-START)

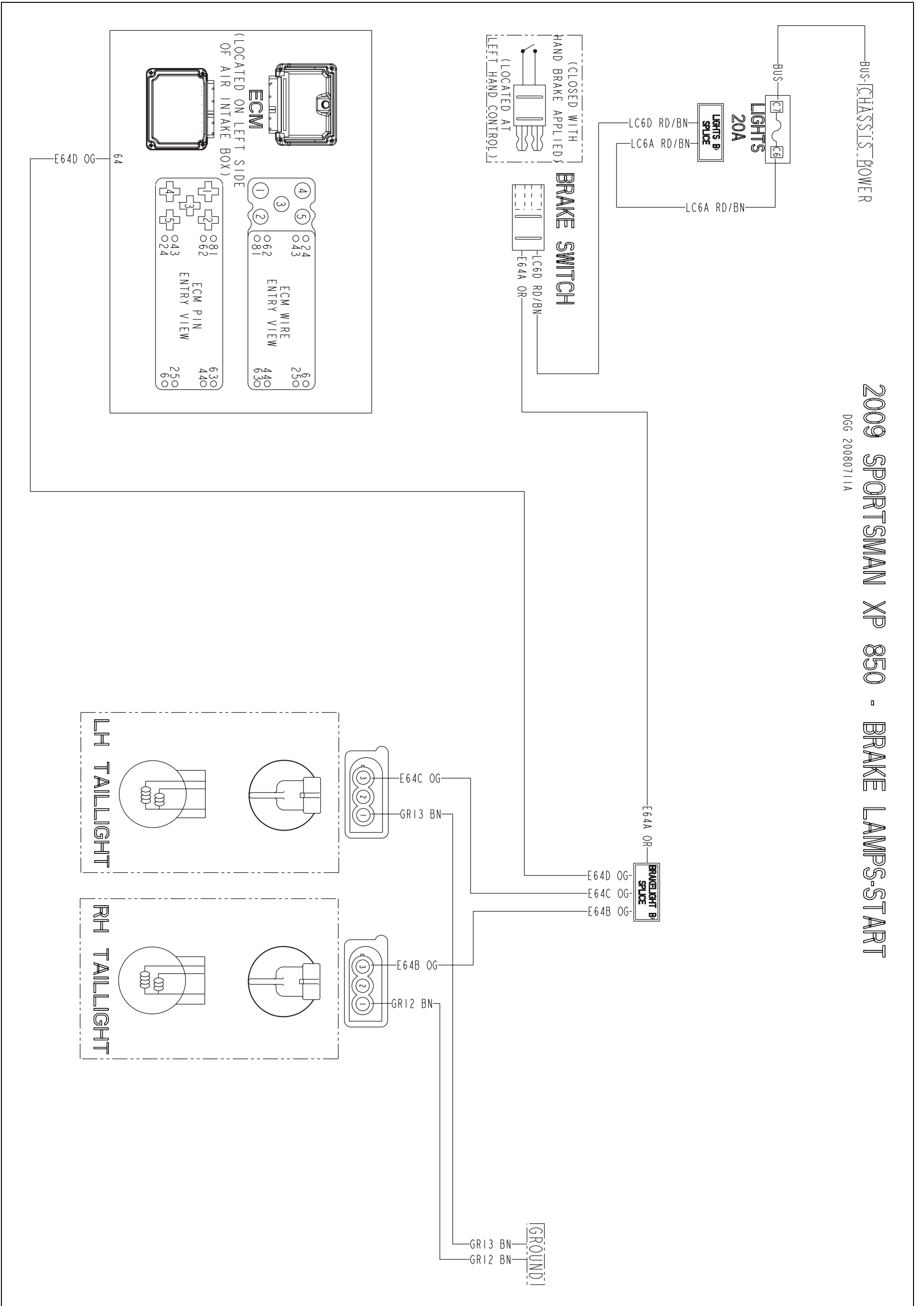

2009 SPORTSMAN XP 850 (CHASSIS POWER)

2009 SPORTSMAN XP 850 - CHASSIS POWER

THESE CIRCUITS WILL BE POWERED WHEN:

1. THE BATTERY IS CONNECTED (SEE BATTERY PLUS)
 2. THE KEY SWITCH AND RUN THE RUN/STOP SWITCH ARE CLOSED (SEE KEY-ON POWER)
 3. THE CHASSIS RELAY CLOSES
- DGG 20080821A

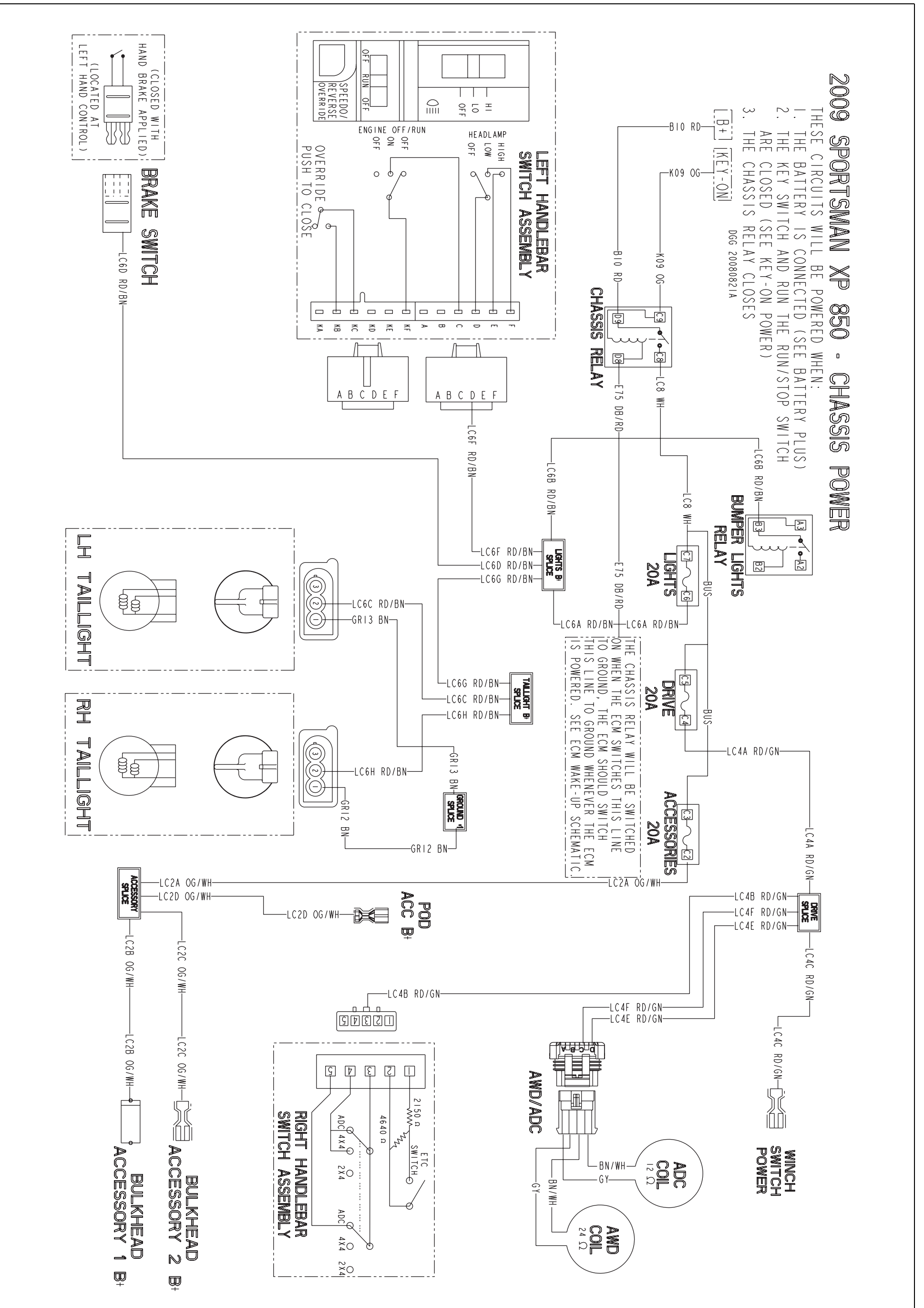

2009 SPORTSMAN XP 850 (COOLING FAN)

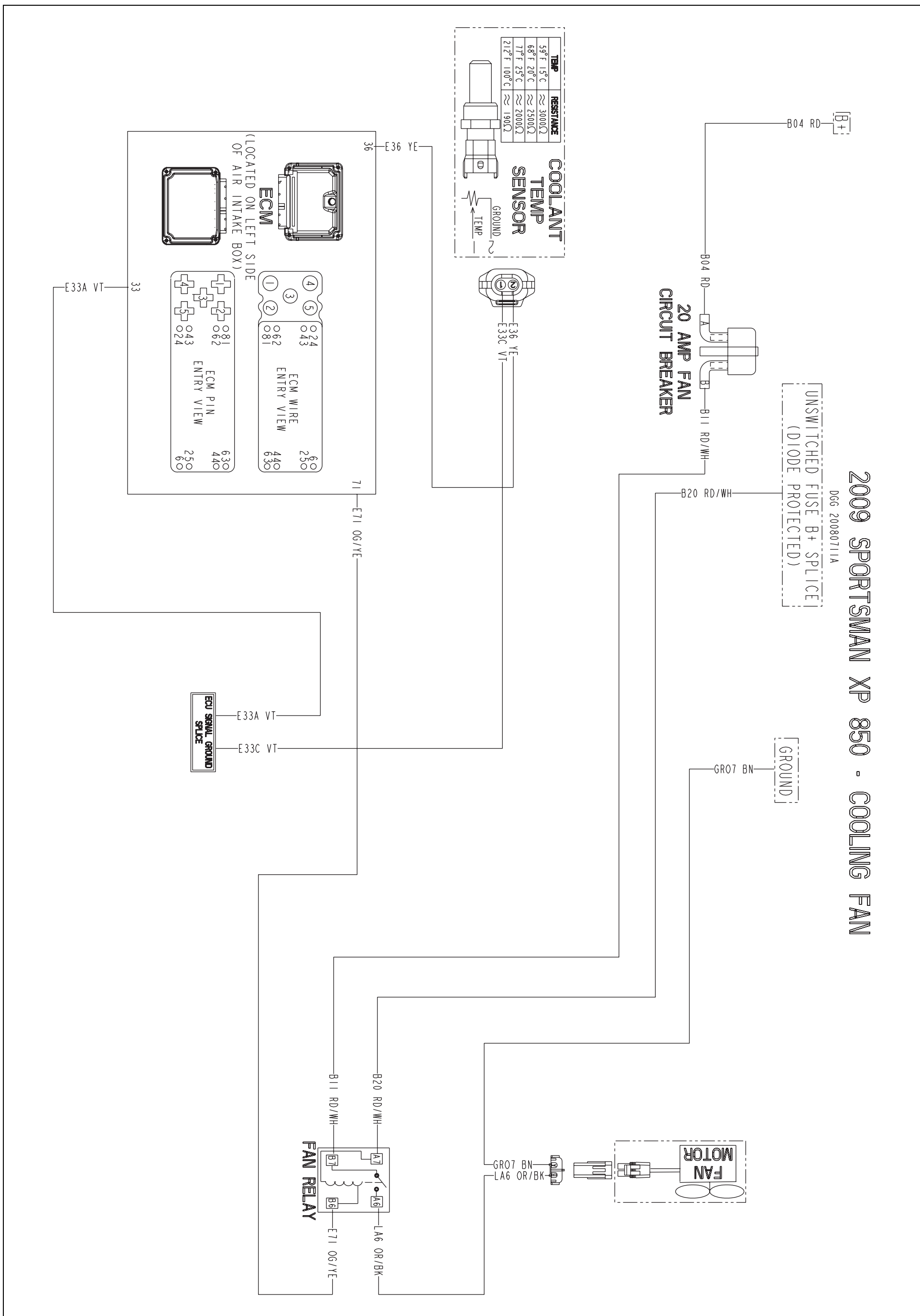

2009 SPORTSMAN XP 850 (ECM WAKE-UP)

2009 SPORTSMAN XP 850 - ECM WAKE-UP
DGG 20080711A

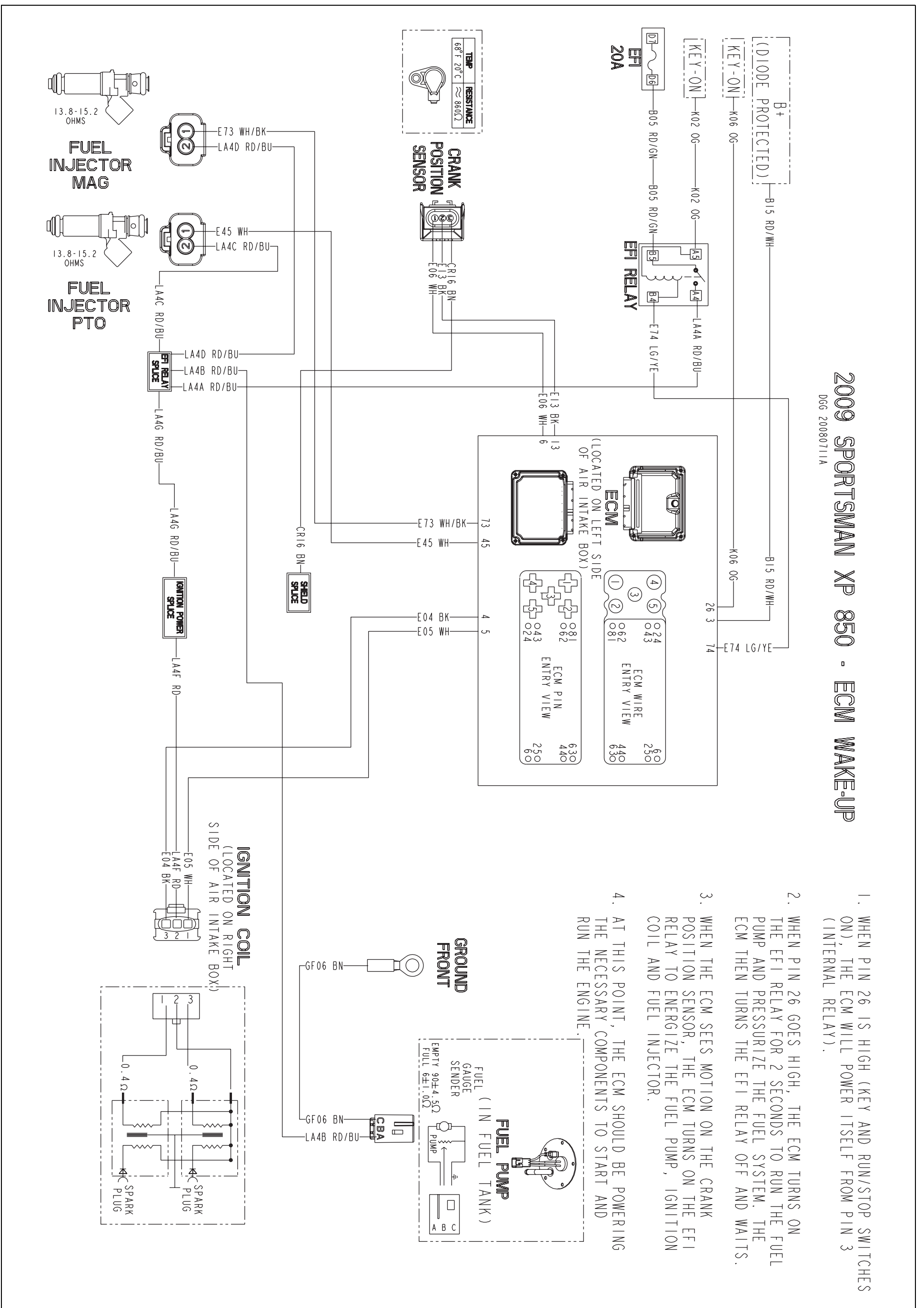

2009 SPORTSMAN XP 850 (EFI)

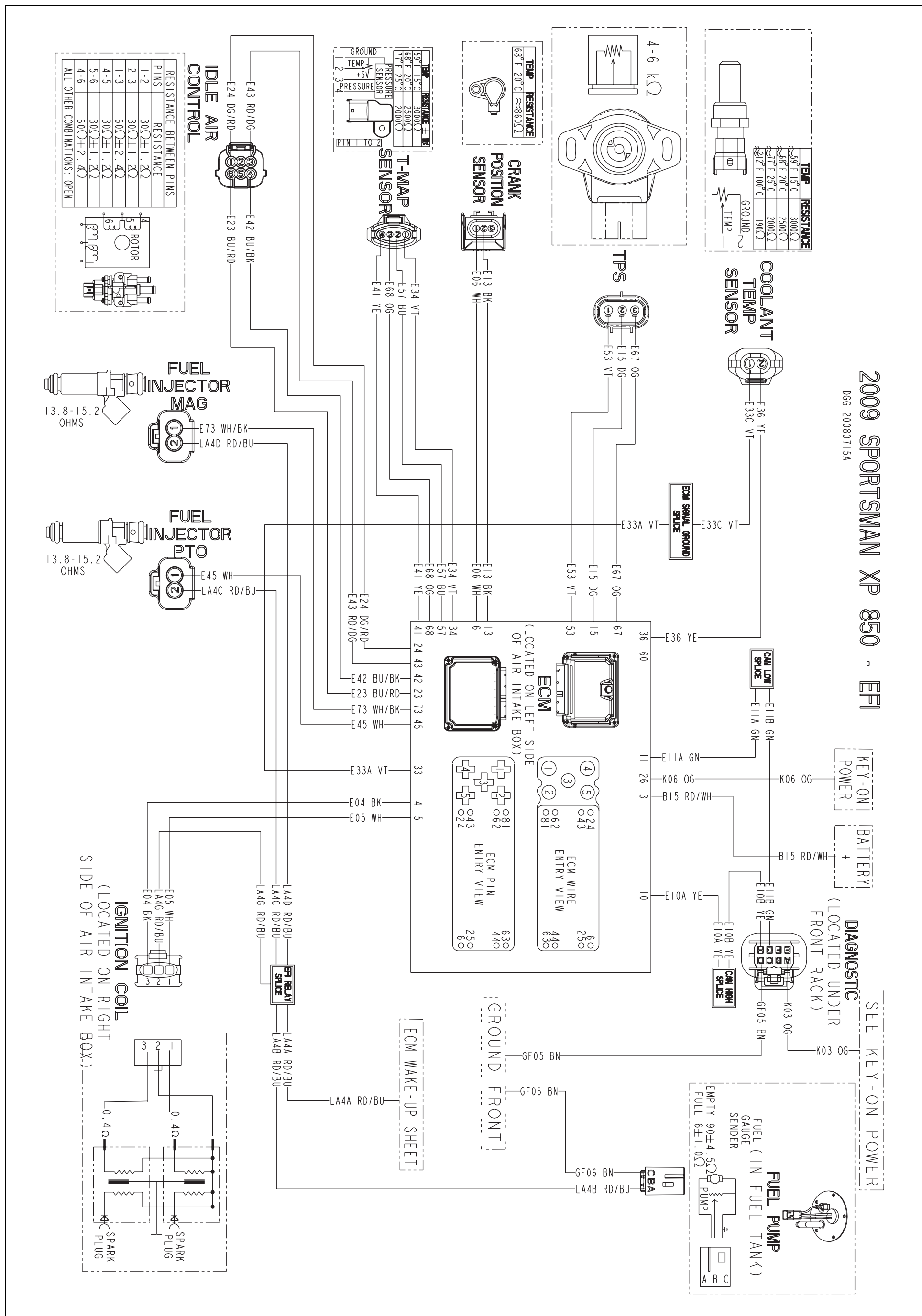

2009 SPORTSMAN XP 850 (ENGINE CRANK)

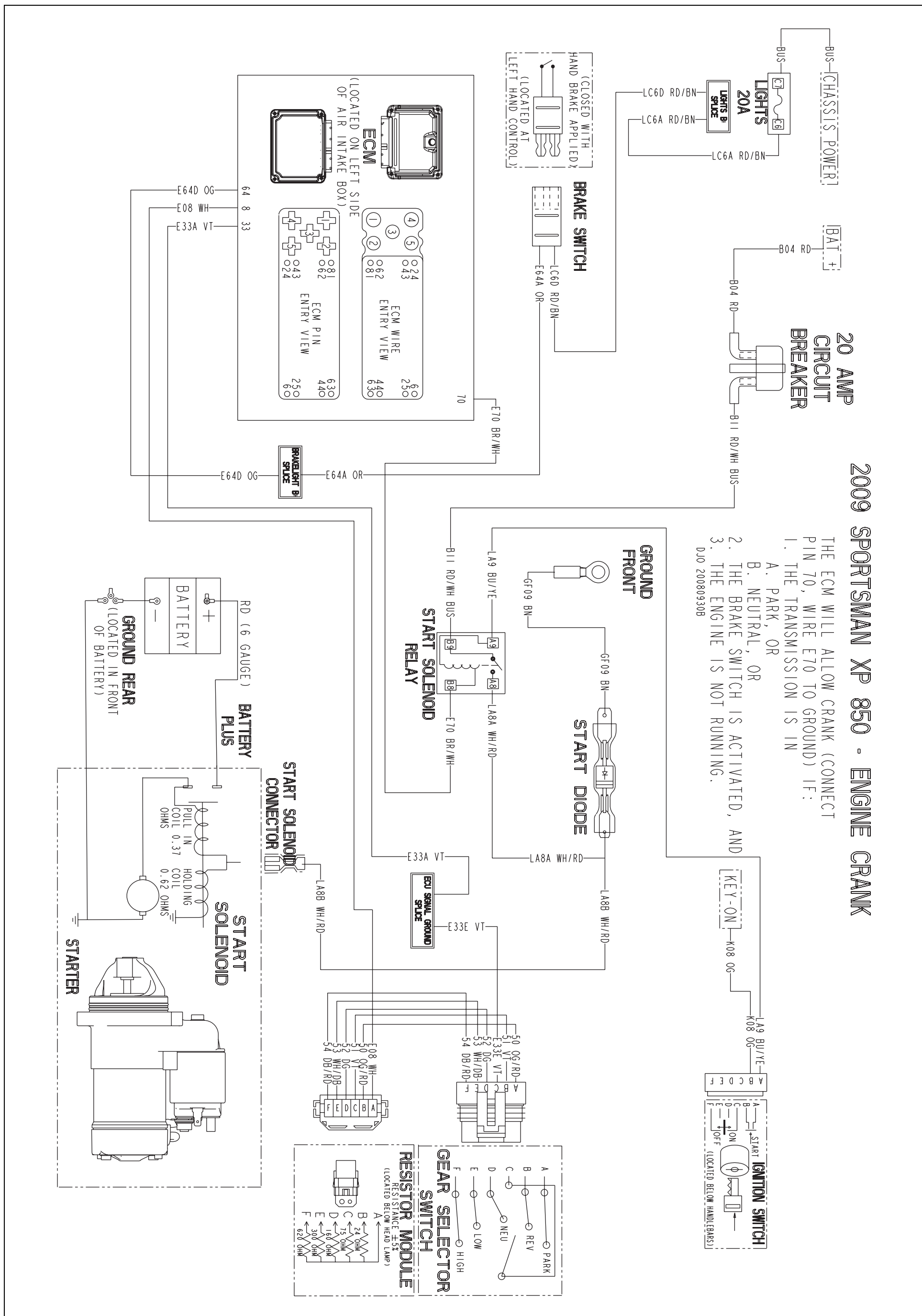

2009 SPORTSMAN XP 850 (EPS)

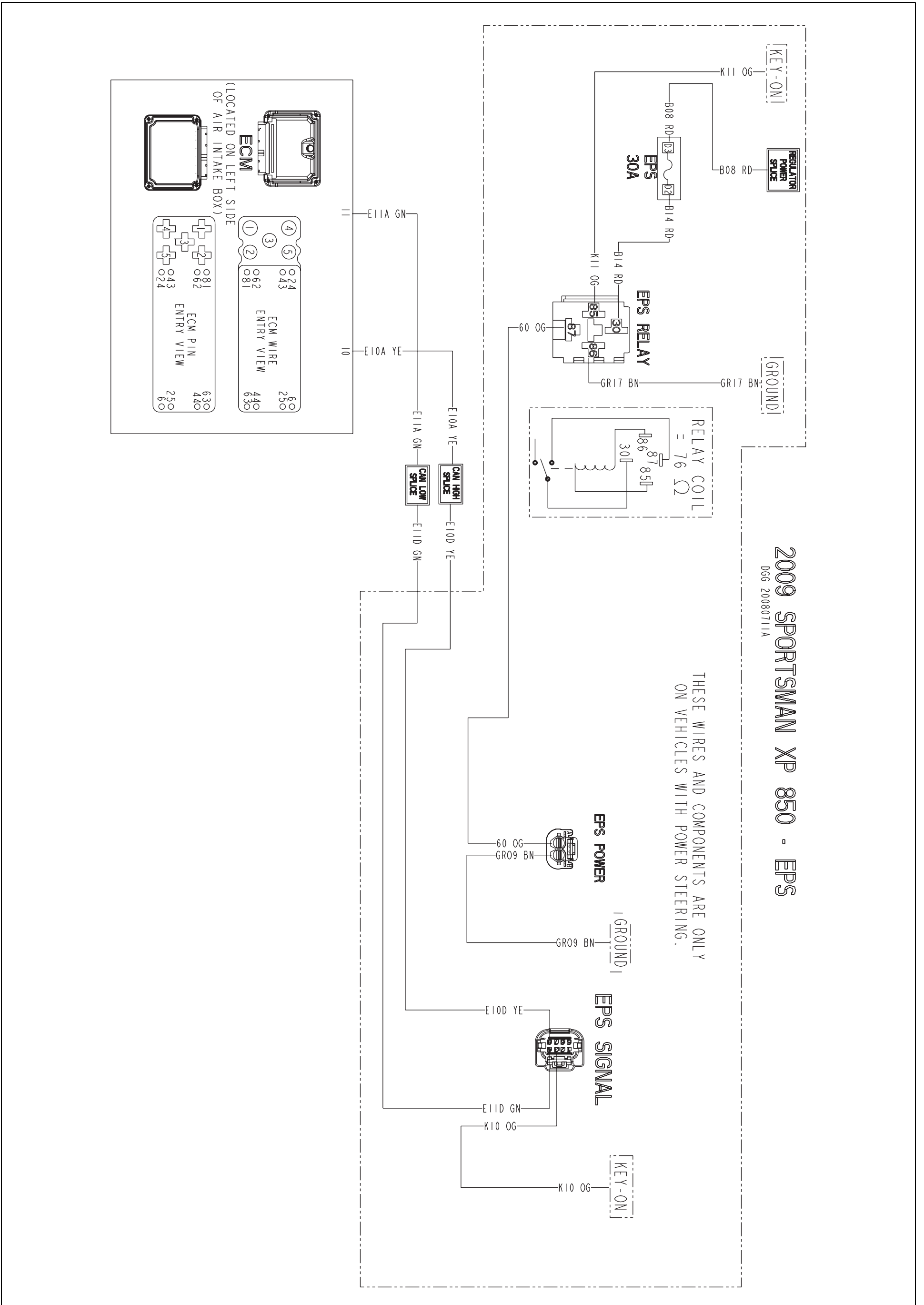

2009 SPORTSMAN XP 850 (FUEL PUMP & LEVEL)

2009 SPORTSMAN XP 850 - FUEL PUMP & LEVEL
DGG 20080715A

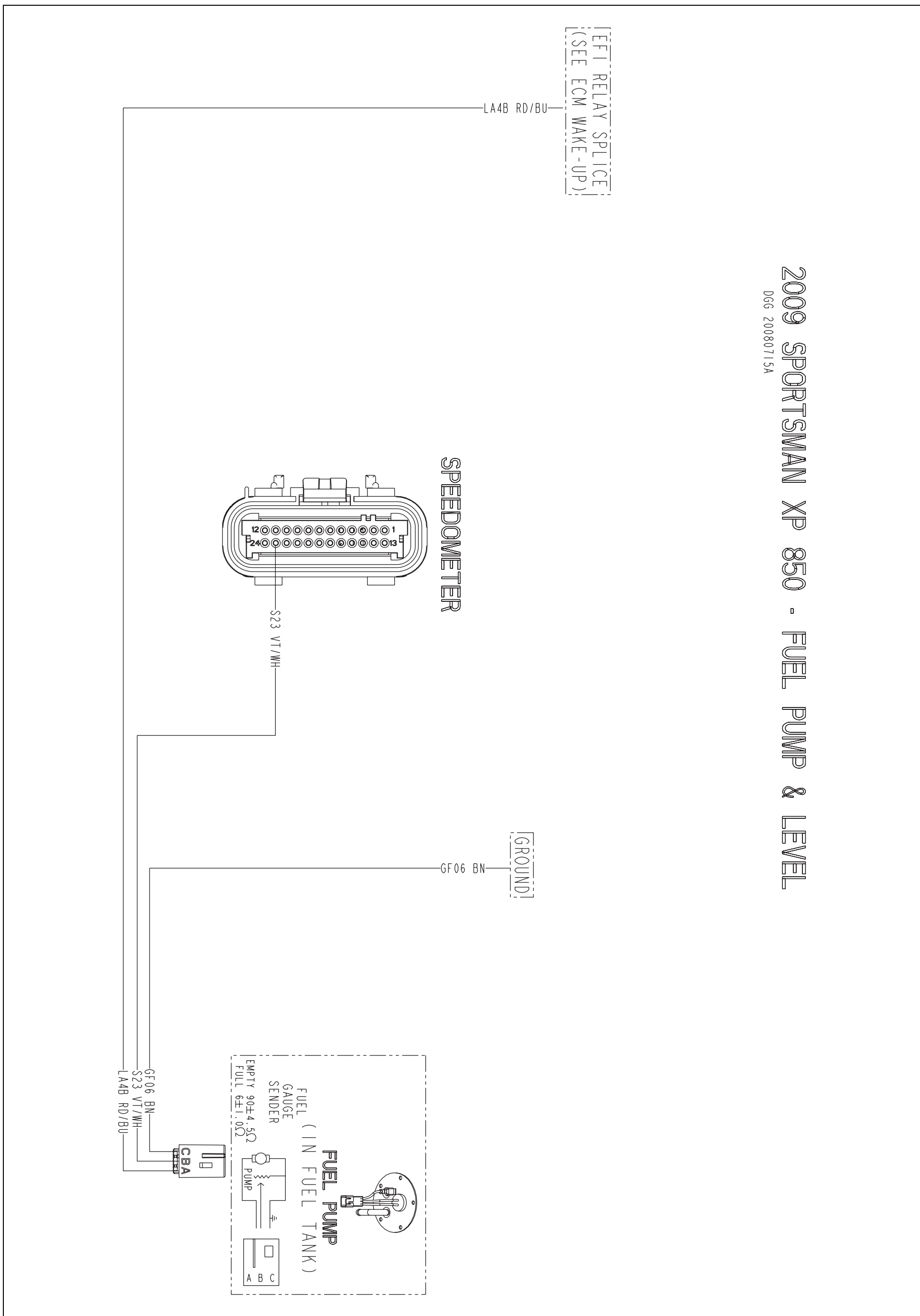

2009 SPORTSMAN XP 850 (GEAR SENSOR)

2009 SPORTSMAN XP 850 - GEAR SENSE
DJ0 20080930B

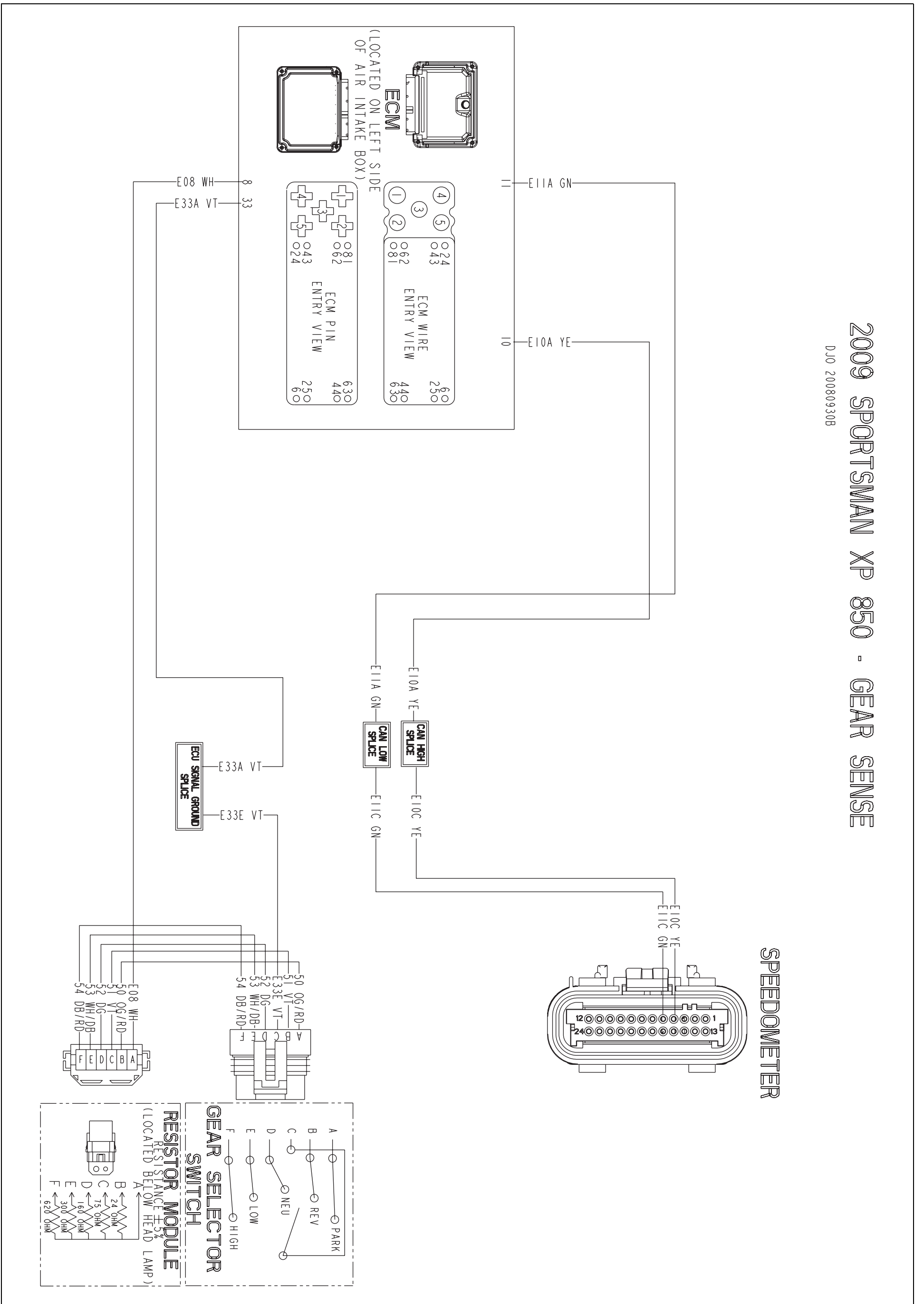

2009 SPORTSMAN XP 850 (GROUND SPEED SENSOR)

2009 SPORTSMAN XP 850 - GROUND SPEED
 DGG 20080821A

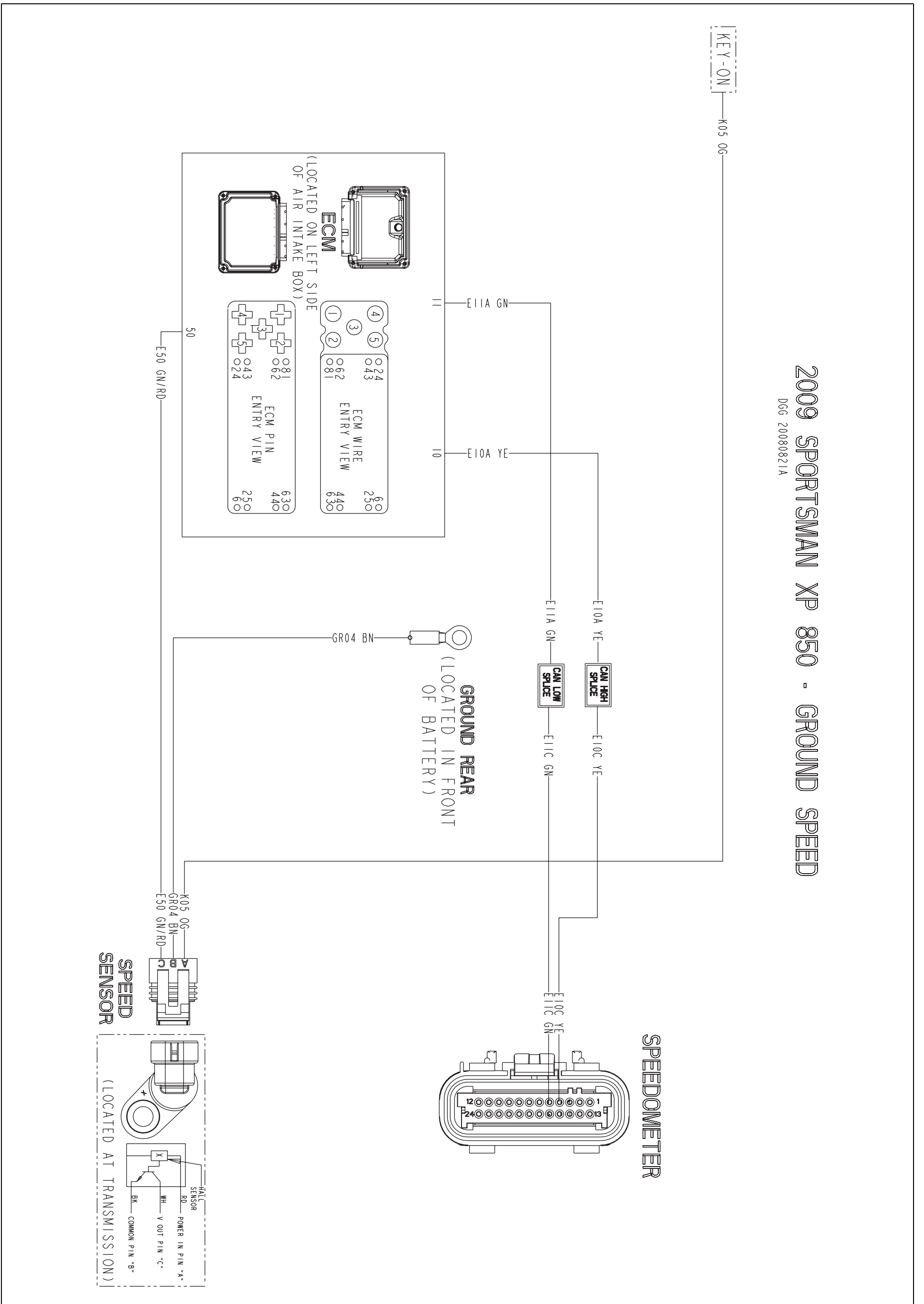

2009 SPORTSMAN XP 850 (KEY ON POWER)

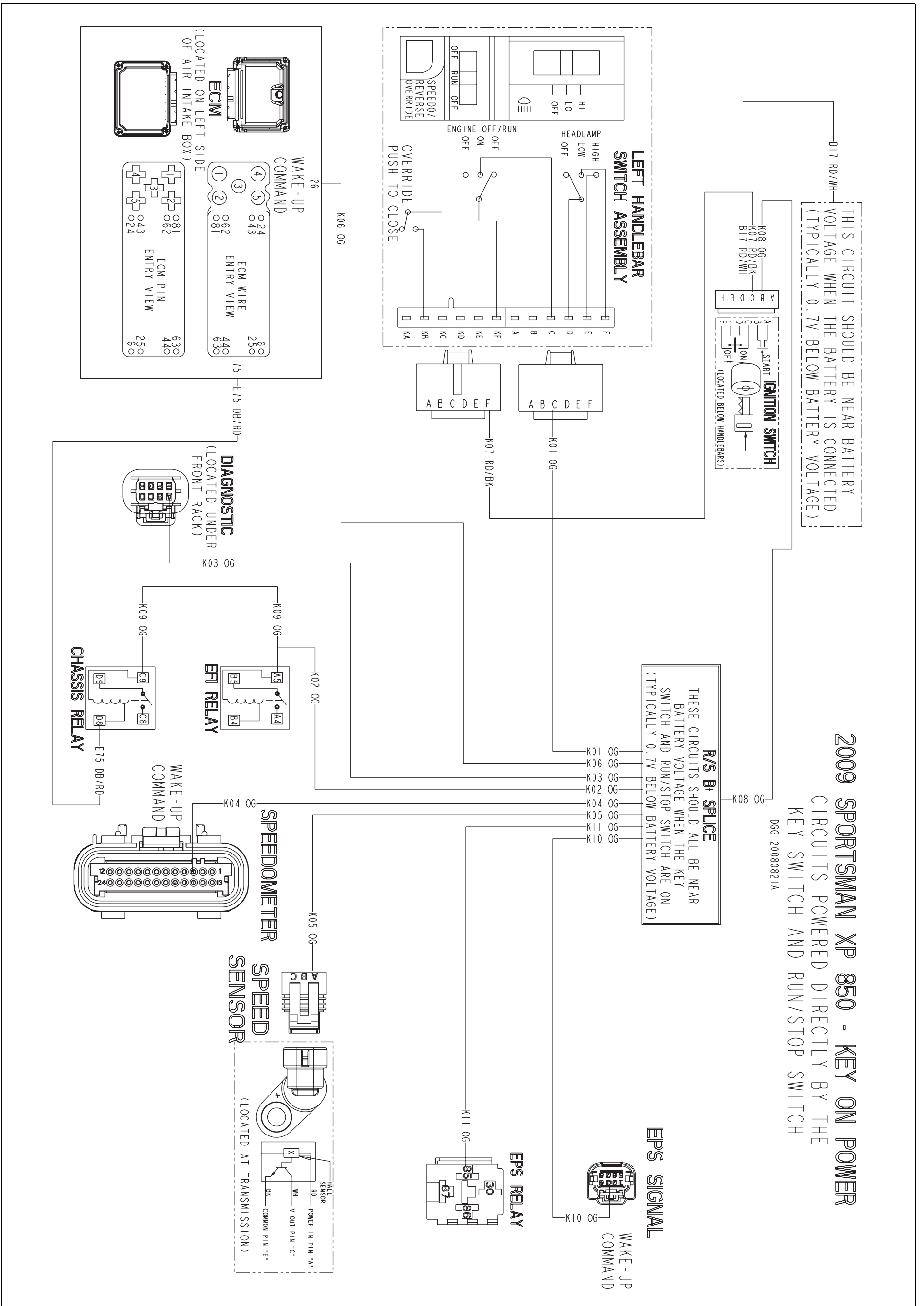

2009 SPORTSMAN XP 850 (HEADLAMPS)

