

**YAMAHA**

**YFM660RN  
YFM660RNC**

**SERVICE MANUAL**

---

## NOTICE

This manual was produced by the Yamaha Motor Company primarily for use by Yamaha dealers and their qualified mechanics. It is not possible to include all the knowledge of a mechanic in one manual, so it is assumed that anyone who uses this book to perform maintenance and repairs on Yamaha machine has a basic understanding of the mechanical ideas and the procedures of machine repair. Repairs attempted by anyone without this knowledge are likely to render the machine unsafe and unfit for use.

Yamaha Motor Company, Ltd. is continually striving to improve all its models. Modifications and significant changes in specifications or procedures will be forwarded to all authorized Yamaha dealers and will appear in future editions of this manual where applicable.

**NOTE:**

---

Designs and specifications are subject to change without notice.

---

## IMPORTANT INFORMATION

Particularly important information is distinguished in this manual by the following notations.



The Safety Alert Symbol means ATTENTION! BECOME ALERT! YOUR SAFETY IS INVOLVED!

**WARNING**

Failure to follow WARNING instructions could result in severe injury or death to the machine operator, a bystander or a person inspecting or repairing the machine.

**CAUTION:**

A CAUTION indicates special precautions that must be taken to avoid damage to the machine.

**NOTE:**

A NOTE provides key information to make procedures easier or clearer.

# HOW TO USE THIS MANUAL

## MANUAL ORGANIZATION

This manual consists of chapters for the main categories of subjects. (See “Illustrated symbols”)

1st title ①: This is the title of the chapter with its symbol in the upper right corner of each page.

2nd title ②: This title indicates the section of the chapter and only appears on the first page of each section. It is located in the upper left corner of the page.

3rd title ③: This title indicates a sub-section that is followed by step-by-step procedures accompanied by corresponding illustrations.

## EXPLODED DIAGRAMS

To help identify parts and clarify procedure steps, there are exploded diagrams at the start of each removal and disassembly section.

1. An easy-to-see exploded diagram ④ is provided for removal and disassembly jobs.
2. Numbers ⑤ are given in the order of the jobs in the exploded diagram. A number that is enclosed by a circle indicates a disassembly step.
3. An explanation of jobs and notes is presented in an easy-to-read way by the use of symbol marks ⑥. The meanings of the symbol marks are given on the next page.
4. A job instruction chart ⑦ accompanies the exploded diagram, providing the order of jobs, names of parts, notes in jobs, etc.
5. For jobs requiring more information, the step-by-step format supplements ⑧ are given in addition to the exploded diagram and the job instruction chart.

②

CLUTCH

①

ENG

④

⑤

⑥

⑦

Order	Job name/Part name	Qty	Remarks
<b>Removing the clutch cover</b>			
	Engine assembly		Remove the parts in the order below. Refer to "ENGINE REMOVAL".
1	Oil filter bolt	1	
2	Union bolt	2	
3	Copper washer	4	
4	Oil delivery pipe 1	1	
5	Union bolt	2	
6	Copper washer	4	
7	Oil delivery pipe 2	1	
8	Clutch cover	1	Refer to "REMOVING/INSTALLING THE CLUTCH".
9	Clutch cover gasket	1	
10	Dowel pin	2	For installation, reverse the removal procedure.

③

CLUTCH ENG

**REMOVING THE CLUTCH**

1. Remove:

- Clutch cover

**NOTE:**  
Loosen each bolt 1/4 of a turn at a time, in stages and in a crisscross pattern. After all of the bolts are fully loosened, remove them.

2. Straighten the lock washer tab.

3. Loosen:

- Clutch boss nut ①

**NOTE:**  
While holding the clutch boss ② with the clutch holding tool ③, loosen the clutch boss nut.

**Clutch holding tool:**  
P/N. YM-91042, 90890-04086

**REMOVING THE PRIMARY DRIVE GEAR AND BALANCER DRIVEN GEAR**

1. Straighten the lock washer tabs.

2. Loosen:

- Primary drive gear nut ①
- Balancer driven gear nut ②

**NOTE:**  
Place an aluminum plate ④ between the teeth of the balancer drive gear ⑤ and balancer driven gear ⑥.

5 - 43

5 - 47

**ILLUSTRATED SYMBOLS**

Illustrated symbols ① to ⑨ are printed on the top right of each page and indicate the subject of each chapter.

- ① General information
- ② Specifications
- ③ Periodic checks and adjustments
- ④ Chassis
- ⑤ Engine
- ⑥ Cooling system
- ⑦ Carburetion
- ⑧ Electrical
- ⑨ Troubleshooting

Illustrated symbols ⑩ to ⑰ are used to identify the specifications appearing in the text.

- ⑩ Can be serviced with engine mounted
- ⑪ Filling fluid
- ⑫ Lubricant
- ⑬ Special tool
- ⑭ Torque
- ⑮ Wear limit, clearance
- ⑯ Engine speed
- ⑰  $\Omega$ , V, A

Illustrated symbols ⑱ to ⑳ in the exploded diagrams indicate the types of lubricants and lubrication points.







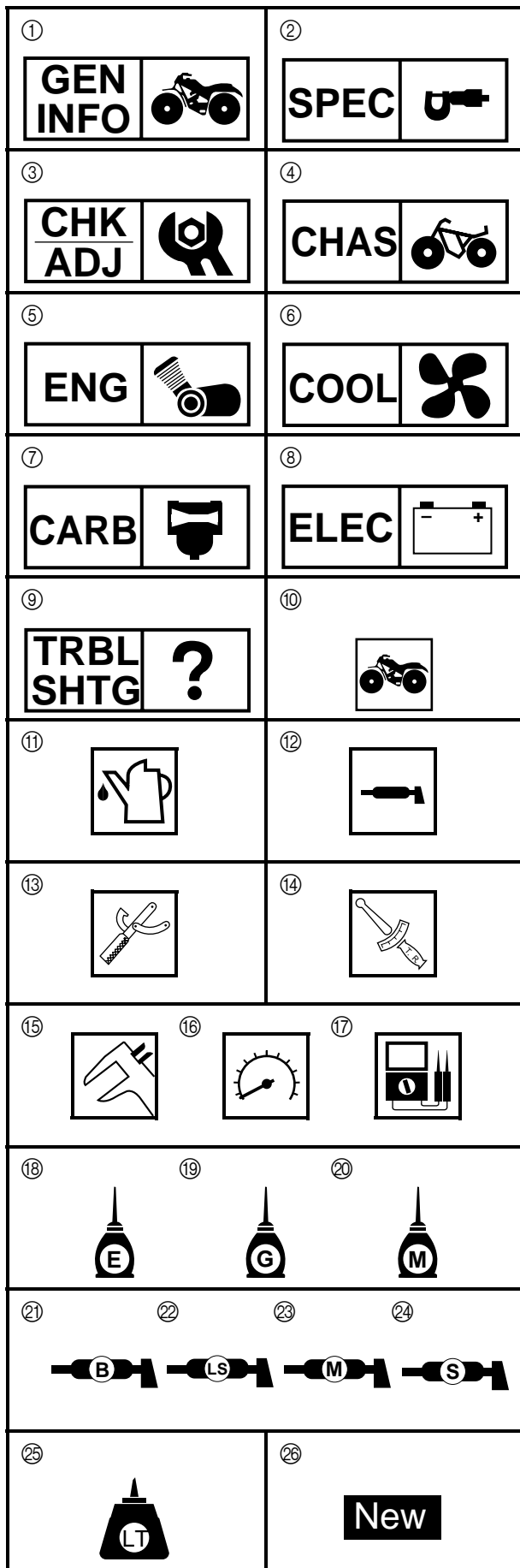

- ⑱ Apply engine oil
- ⑲ Apply gear oil
- ⑳ Apply molybdenum disulfide oil
- ㉑ Apply wheel bearing grease
- ㉒ Apply lightweight lithium soap base grease
- ㉓ Apply molybdenum disulfide grease
- ㉔ Apply silicon grease

Illustrated symbols ㉕ to ㉖ in the exploded diagrams indicate where to apply a locking agent ㉕ and when to install a new part ㉖.

- ㉕ Apply the locking agent (LOCTITE®)
- ㉖ Replace



# TABLE OF CONTENTS

<b>GENERAL INFORMATION</b>	
	<b>GEN INFO 1</b>
<b>SPECIFICATIONS</b>	
	<b>SPEC 2</b>
<b>PERIODIC CHECKS AND ADJUSTMENTS</b>	
	<b>CHK ADJ 3</b>
<b>CHASSIS</b>	
	<b>CHAS 4</b>
<b>ENGINE</b>	
	<b>ENG 5</b>
<b>COOLING SYSTEM</b>	
	<b>COOL 6</b>
<b>CARBURETION</b>	
	<b>CARB 7</b>
<b>ELECTRICAL</b>	
	<b>ELEC 8</b>
<b>TROUBLESHOOTING</b>	
	<b>TRBL SHTG 9</b>

---

## CHAPTER 1. GENERAL INFORMATION









<b>MACHINE IDENTIFICATION</b> .....	1-1
VEHICLE IDENTIFICATION NUMBER .....	1-1
MODEL LABEL .....	1-1
<b>IMPORTANT INFORMATION</b> .....	1-2
PREPARATION FOR REMOVAL PROCEDURES .....	1-2
REPLACEMENT PARTS .....	1-2
GASKETS, OIL SEALS AND O-RINGS .....	1-2
LOCK WASHERS/PLATES AND COTTER PINS .....	1-3
BEARINGS AND OIL SEALS .....	1-3
CIRCLIPS .....	1-3
<b>CHECKING OF CONNECTIONS</b> .....	1-4
<b>SPECIAL TOOLS</b> .....	1-5

## CHAPTER 2. SPECIFICATIONS

<b>GENERAL SPECIFICATIONS</b> .....	2-1
<b>MAINTENANCE SPECIFICATIONS</b> .....	2-4
ENGINE .....	2-4
CHASSIS .....	2-14
ELECTRICAL .....	2-18
<b>HOW TO USE THE CONVERSION TABLE</b> .....	2-20
<b>GENERAL TORQUE SPECIFICATIONS</b> .....	2-20
<b>LUBRICATION POINTS AND LUBRICANT TYPES</b> .....	2-21
ENGINE .....	2-21
<b>COOLANT FLOW DIAGRAMS</b> .....	2-22
<b>OIL FLOW DIAGRAMS</b> .....	2-23
<b>CABLE ROUTING</b> .....	2-27

## CHAPTER 3. PERIODIC CHECKS AND ADJUSTMENTS

<b>INTRODUCTION</b> .....	3-1
<b>PERIODIC MAINTENANCE/LUBRICATION INTERVALS</b> .....	3-1
<b>SEAT, FENDERS AND FUEL TANK</b> .....	3-3
SEAT, FRONT PANEL, FOOTREST GUARDS AND ENGINE SKID PLATE .....	3-3
HEADLIGHTS AND FRONT FENDER .....	3-4
REAR FENDER .....	3-5
FUEL TANK .....	3-6
<b>ENGINE</b> .....	3-8
ADJUSTING THE VALVE CLEARANCE .....	3-8
ADJUSTING THE TIMING CHAIN .....	3-11
ADJUSTING THE IDLING SPEED .....	3-11
ADJUSTING THE THROTTLE LEVER FREE PLAY .....	3-12
ADJUSTING THE SPEED LIMITER .....	3-14
ADJUSTING THE STARTER CABLE .....	3-15
CHECKING THE SPARK PLUG .....	3-16
CHECKING THE IGNITION TIMING .....	3-17
MEASURING THE COMPRESSION PRESSURE .....	3-18
CHECKING THE ENGINE OIL LEVEL .....	3-19
CHANGING THE ENGINE OIL .....	3-20
ADJUSTING THE CLUTCH CABLE .....	3-23
CLEANING THE AIR FILTER .....	3-24
CHECKING THE COOLANT LEVEL .....	3-27
CHANGING THE COOLANT .....	3-27
CHECKING THE COOLANT TEMPERATURE WARNING LIGHT .....	3-31
CLEANING THE SPARK ARRESTER .....	3-31
<b>CHASSIS</b> .....	3-33
ADJUSTING THE FRONT BRAKE .....	3-33
ADJUSTING THE REAR BRAKE .....	3-33
ADJUSTING THE PARKING BRAKE .....	3-34
CHECKING THE BRAKE FLUID LEVEL .....	3-35
CHECKING THE FRONT BRAKE PAD .....	3-36
CHECKING THE REAR BRAKE PAD .....	3-36
ADJUSTING THE REAR BRAKE LIGHT SWITCH .....	3-36
CHECKING THE BRAKE HOSE .....	3-37
BLEEDING THE HYDRAULIC BRAKE SYSTEM .....	3-38
ADJUSTING THE SHIFT PEDAL .....	3-39
ADJUSTING THE REVERSE CONTROL CABLE .....	3-40
ADJUSTING THE DRIVE CHAIN SLACK .....	3-40
CHECKING THE STEERING SYSTEM .....	3-42
ADJUSTING THE TOE-IN .....	3-42
ADJUSTING THE FRONT SHOCK ABSORBER .....	3-44
ADJUSTING THE REAR SHOCK ABSORBER .....	3-45

	
<b>GEN INFO</b>	<b>1</b>
	
<b>SPEC</b>	<b>2</b>
	
<b>CHK ADJ</b>	<b>3</b>
	
<b>CHAS</b>	<b>4</b>
	
<b>ENG</b>	<b>5</b>
	
<b>COOL</b>	<b>6</b>
	
<b>CARB</b>	<b>7</b>
	
<b>ELEC</b>	<b>8</b>
	
<b>TRBL SHTG</b>	<b>9</b>

---

CHECKING THE TIRE .....	3-47
CHECKING THE WHEEL .....	3-49
CHECKING AND LUBRICATING THE CABLE .....	3-49
LUBRICATING THE LEVERS AND PEDAL .....	3-50
<b>ELECTRICAL</b> .....	3-51
CHECKING THE BATTERY .....	3-51
CHECKING THE FUSE .....	3-56
ADJUSTING THE HEADLIGHT BEAM .....	3-58
REPLACING THE HEADLIGHT BULB .....	3-58

## CHAPTER 4. CHASSIS

<b>FRONT WHEELS</b> .....	4-1
FRONT WHEELS .....	4-1
CHECKING THE WHEEL .....	4-3
CHECKING THE WHEEL HUB .....	4-3
CHECKING THE BRAKE DISC .....	4-4
INSTALLING WHEEL HUB .....	4-5
INSTALLING THE WHEEL .....	4-5
<b>REAR WHEELS, WHEEL AXLE AND HUB</b> .....	4-6
REAR WHEELS .....	4-6
WHEEL AXLE AND HUB .....	4-7
REMOVING THE REAR AXLE .....	4-9
CHECKING THE WHEEL .....	4-10
CHECKING THE WHEEL HUB .....	4-10
CHECKING THE REAR AXLE .....	4-10
CHECKING THE HUB .....	4-11
CHECKING THE BRAKE DISC .....	4-11
INSTALLING THE NUTS (REAR AXLE) .....	4-11
INSTALLING THE WHEEL HUB .....	4-12
INSTALLING THE WHEEL .....	4-12
<b>FRONT AND REAR BRAKES</b> .....	4-13
FRONT BRAKE PADS .....	4-13
REAR BRAKE PADS .....	4-14
REPLACING THE FRONT BRAKE PAD .....	4-15
REPLACING THE REAR BRAKE PAD .....	4-17
FRONT BRAKE MASTER CYLINDER .....	4-19
REAR BRAKE MASTER CYLINDER .....	4-21
CHECKING THE MASTER CYLINDER .....	4-24
ASSEMBLING THE FRONT AND REAR BRAKE MASTER CYLINDER .....	4-25
INSTALLING THE FRONT BRAKE MASTER CYLINDER .....	4-25
INSTALLING THE REAR BRAKE MASTER CYLINDER .....	4-27
FRONT BRAKE CALIPERS .....	4-29
REAR BRAKE CALIPER .....	4-31
DISASSEMBLING THE FRONT AND REAR BRAKE CALIPER .....	4-34



CHECKING THE FRONT AND REAR BRAKE CALIPER .....	4-34
ASSEMBLING THE FRONT BRAKE CALIPER .....	4-35
ASSEMBLING THE REAR BRAKE CALIPER .....	4-36
INSTALLING THE FRONT BRAKE CALIPER .....	4-37
INSTALLING THE REAR BRAKE CALIPER .....	4-38
<b>STEERING SYSTEM</b> .....	4-40
HANDLEBAR .....	4-40
REMOVING THE FRONT BRAKE SWITCH, PARK SWITCH AND CLUTCH SWITCH .....	4-42
REMOVING THE HANDLEBAR GRIP .....	4-42
CHECKING THE HANDLEBAR .....	4-42
INSTALLING THE HANDLEBAR .....	4-43
INSTALLING THE HANDLEBAR GRIP .....	4-43
INSTALLING THE CLUTCH LEVER .....	4-43
INSTALLING THE BRAKE MASTER CYLINDER .....	4-44
STEERING STEM .....	4-45
REMOVING THE BEARING RETAINER .....	4-47
CHECKING THE STEERING STEM .....	4-47
INSTALLING THE BEARING RETAINER .....	4-47
INSTALLING THE LOCK WASHER .....	4-47
TIE-ROD AND STEERING KNUCKLE .....	4-48
REMOVING THE STEERING KNUCKLE .....	4-49
CHECKING THE TIE-ROD .....	4-49
CHECKING THE STEERING KNUCKLE .....	4-49
INSTALLING THE TIE-ROD .....	4-49
<b>FRONT ARMS AND FRONT SHOCK ABSORBERS</b> .....	4-50
REMOVING THE FRONT ARM .....	4-52
CHECKING THE FRONT ARM .....	4-52
CHECKING THE FRONT SHOCK ABSORBER .....	4-52
CHECKING THE BALL JOINT .....	4-53
INSTALLING THE FRONT ARM .....	4-54
<b>REAR SHOCK ABSORBER AND RELAY ARM</b> .....	4-55
HANDLING THE REAR SHOCK ABSORBER AND GAS CYLINDER .....	4-57
DISPOSING OF A REAR SHOCK ABSORBER AND GAS CYLINDER .....	4-57
REMOVING THE REAR SHOCK ABSORBER .....	4-58
CHECKING THE REAR SHOCK ABSORBER .....	4-58
CHECKING THE RELAY ARM AND CONNECTING ARM .....	4-58
INSTALLING THE RELAY ARM AND CONNECTING ARM .....	4-59
INSTALLING THE REAR SHOCK ABSORBER .....	4-59
<b>SWINGARM AND DRIVE CHAIN</b> .....	4-60
REMOVING THE SWINGARM .....	4-62
CHECKING THE SWINGARM .....	4-62
CHECKING THE DRIVE CHAIN .....	4-63
INSTALLING THE SWINGARM .....	4-65
INSTALLING THE DRIVE SPROCKET .....	4-65

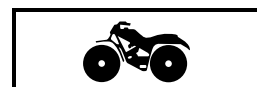

**GEN  
INFO** **1**



**SPEC** **2**



**CHK  
ADJ** **3**



**CHAS** **4**



**ENG** **5**



**COOL** **6**



**CARB** **7**



**ELEC** **8**











**TRBL  
SHTG** **9**

---

## CHAPTER 5. ENGINE

<b>ENGINE REMOVAL</b> .....	5-1
MUFFLER AND EXHAUST PIPES .....	5-1
LEFT FOOTREST .....	5-2
LEADS, CABLES AND HOSES .....	5-3
ENGINE MOUNTING BOLTS .....	5-5
INSTALLING THE ENGINE .....	5-7
<b>CYLINDER HEAD COVER</b> .....	5-8
REMOVING THE CYLINDER HEAD COVER .....	5-10
CHECKING THE CYLINDER HEAD COVER .....	5-10
CHECKING THE TAPPET COVER .....	5-11
INSTALLING THE CYLINDER HEAD COVER .....	5-11
<b>ROCKER ARMS</b> .....	5-12
REMOVING THE ROCKER ARM .....	5-14
CHECKING THE ROCKER ARM .....	5-14
INSTALLING THE ROCKER ARM .....	5-15
<b>CAMSHAFT AND CYLINDER HEAD</b> .....	5-16
REMOVING THE CAMSHAFT AND CYLINDER HEAD .....	5-18
CHECKING THE CAMSHAFT .....	5-19
CHECKING THE CAMSHAFT SPROCKET .....	5-19
CHECKING THE DECOMPRESSION SYSTEM .....	5-19
CHECKING THE TIMING CHAIN GUIDE .....	5-20
CHECKING THE TIMING CHAIN TENSIONER .....	5-20
CHECKING THE CYLINDER HEAD .....	5-20
INSTALLING THE CAMSHAFT AND CYLINDER HEAD .....	5-21
<b>VALVES AND VALVE SPRINGS</b> .....	5-24
REMOVING THE VALVE AND VALVE SPRING .....	5-25
CHECKING THE VALVE AND VALVE SPRING .....	5-26
INSTALLING THE VALVE AND VALVE SPRING .....	5-30
<b>CYLINDER AND PISTON</b> .....	5-32
REMOVING THE PISTON .....	5-33
CHECKING THE CYLINDER AND PISTON .....	5-33
CHECKING THE PISTON RING .....	5-35
CHECKING THE PISTON PIN INSPECTION .....	5-36
INSTALLING THE PISTON .....	5-36
INSTALLING THE CYLINDER .....	5-37
<b>AC MAGNETO</b> .....	5-38
REMOVING THE AC MAGNETO ROTOR .....	5-40
CHECKING THE COIL .....	5-40
CHECKING THE STARTER CLUTCH .....	5-41
INSTALLING THE AC MAGNETO ROTOR .....	5-42

<b>CLUTCH</b> .....	5-43
REMOVING THE CLUTCH .....	5-47
REMOVING THE PRIMARY DRIVE GEAR AND BALANCER DRIVEN GEAR .....	5-47
CHECKING THE FRICTION PLATE .....	5-48
CHECKING THE CLUTCH PLATE .....	5-48
CHECKING THE CLUTCH SPRING .....	5-49
CHECKING THE CLUTCH HOUSING .....	5-49
CHECKING THE CLUTCH BOSS .....	5-49
CHECKING THE PRESSURE PLATE .....	5-49
CHECKING THE PULL LEVER SHAFT AND PULL ROD .....	5-50
CHECKING THE PRIMARY DRIVE .....	5-50
CHECKING THE BALANCER DRIVE .....	5-50
INSTALLING THE PRIMARY DRIVE GEAR AND BALANCER DRIVEN GEAR .....	5-51
INSTALLING THE CLUTCH .....	5-52
 <b>OIL PUMP</b> .....	5-54
CHECKING THE OIL PUMP .....	5-56
ASSEMBLING THE OIL PUMP .....	5-56
 <b>SHIFT SHAFT</b> .....	5-57
CHECKING THE SHIFT SHAFT .....	5-59
CHECKING THE STOPPER LEVER .....	5-59
CHECKING THE SHIFT GUIDE AND SHIFT LEVER .....	5-59
CHECKING THE SEGMENT .....	5-59
INSTALLING THE SHIFT LEVER .....	5-59
INSTALLING THE STOPPER LEVER .....	5-60
INSTALLING THE SHIFT SHAFT .....	5-61
 <b>CRANKCASE</b> .....	5-62
TIMING CHAIN AND SPEED SENSOR ROTOR .....	5-62
CRANKCASE .....	5-64
CRANKCASE BEARING .....	5-65
SEPARATING THE CRANKCASE .....	5-66
CHECKING THE TIMING CHAIN AND GUIDE .....	5-66
CHECKING THE OIL STRAINER .....	5-66
CHECKING THE CRANKCASE .....	5-67
CHECKING THE BEARINGS .....	5-67
ASSEMBLING THE CRANKCASE .....	5-67
 <b>CRANKSHAFT AND BALANCER</b> .....	5-69
REMOVING THE CRANKSHAFT .....	5-70
CHECKING THE CRANKSHAFT .....	5-70
INSTALLING THE CRANKSHAFT .....	5-71

	
<b>GEN INFO</b>	<b>1</b>
	
<b>SPEC</b>	<b>2</b>
	
<b>CHK ADJ</b>	<b>3</b>
	
<b>CHAS</b>	<b>4</b>
	
<b>ENG</b>	<b>5</b>
	
<b>COOL</b>	<b>6</b>
	
<b>CARB</b>	<b>7</b>
	
<b>ELEC</b>	<b>8</b>
<b>?</b>	
<b>TRBL SHTG</b>	<b>9</b>

---

<b>TRANSMISSION</b> .....	5-72
MAIN AXLE .....	5-74
DRIVE AXLE .....	5-75
CHECKING THE SHIFT FORK .....	5-77
CHECKING THE SHIFT DRUM .....	5-77
CHECKING THE TRANSMISSION .....	5-77
ASSEMBLING THE MAIN AXLE AND DRIVE AXLE .....	5-78
INSTALLING THE TRANSMISSION .....	5-79

## **CHAPTER 6. COOLING SYSTEM**









<b>RADIATOR</b> .....	6-1
CHECKING THE RADIATOR .....	6-3
INSTALLING THE RADIATOR .....	6-4
<b>THERMOSTAT</b> .....	6-5
CHECKING THE THERMOSTAT .....	6-7
ASSEMBLING THE THERMOSTAT .....	6-7
<b>WATER PUMP</b> .....	6-8
DISASSEMBLING THE WATER PUMP .....	6-11
CHECKING THE WATER PUMP .....	6-11
ASSEMBLING THE WATER PUMP .....	6-12

## **CHAPTER 7. CARBURETION**

<b>CARBURETORS</b> .....	7-1
DISASSEMBLING THE CARBURETOR .....	7-5
CHECKING THE CARBURETOR .....	7-5
ASSEMBLING THE CARBURETOR .....	7-7
ADJUSTING THE FUEL LEVEL .....	7-8

# CHAPTER 8. ELECTRICAL

<b>ELECTRICAL COMPONENTS</b> .....	8-1
<b>CHECKING THE SWITCH</b> .....	8-2
CHECKING THE SWITCH .....	8-2
CHECKING A SWITCH SHOWN IN THE MANUAL .....	8-2
CHECKING THE SWITCH CONTINUITY .....	8-3
<b>IGNITION SYSTEM</b> .....	8-5
CIRCUIT DIAGRAM .....	8-5
TROUBLESHOOTING .....	8-6
<b>ELECTRIC STARTING SYSTEM</b> .....	8-11
CIRCUIT DIAGRAM .....	8-11
STARTING CIRCUIT OPERATION .....	8-12
TROUBLESHOOTING .....	8-13
STARTER MOTOR .....	8-16
CHECKING THE STARTER MOTOR .....	8-17
ASSEMBLING THE STARTER MOTOR .....	8-18
<b>CHARGING SYSTEM</b> .....	8-19
CIRCUIT DIAGRAM .....	8-19
TROUBLESHOOTING .....	8-20
<b>LIGHTING SYSTEM</b> .....	8-22
CIRCUIT DIAGRAM .....	8-22
TROUBLESHOOTING .....	8-23
CHECKING THE LIGHTING SYSTEM .....	8-25
<b>SIGNAL SYSTEM</b> .....	8-27
CIRCUIT DIAGRAM .....	8-27
TROUBLESHOOTING .....	8-28
CHECKING THE SIGNAL SYSTEM .....	8-30
<b>COOLING SYSTEM</b> .....	8-36
CIRCUIT DIAGRAM .....	8-36
TROUBLESHOOTING .....	8-37

	<b>GEN INFO</b>	<b>1</b>
	<b>SPEC</b>	<b>2</b>
	<b>CHK ADJ</b>	<b>3</b>
	<b>CHAS</b>	<b>4</b>
	<b>ENG</b>	<b>5</b>
	<b>COOL</b>	<b>6</b>
	<b>CARB</b>	<b>7</b>
	<b>ELEC</b>	<b>8</b>
	<b>TRBL SHTG</b>	<b>9</b>

---

## CHAPTER 9. TROUBLESHOOTING

<b>STARTING FAILURE/HARD STARTING</b> .....	9-1
FUEL SYSTEM .....	9-1
ELECTRICAL SYSTEM .....	9-1
COMPRESSION SYSTEM .....	9-2
<b>POOR IDLE SPEED PERFORMANCE</b> .....	9-2
POOR IDLE SPEED PERFORMANCE .....	9-2
<b>POOR MEDIUM AND HIGH-SPEED PERFORMANCE</b> .....	9-2
POOR MEDIUM AND HIGH-SPEED PERFORMANCE .....	9-2
<b>FAULTY GEAR SHIFTING</b> .....	9-3
HARD SHIFTING .....	9-3
SHIFT PEDAL DOES NOT MOVE .....	9-3
JUMP-OUT GEAR .....	9-3
<b>CLUTCH SLIPPING/Dragging</b> .....	9-3
CLUTCH SLIPPING .....	9-3
CLUTCH DRAGGING .....	9-3
<b>OVERHEATING</b> .....	9-4
OVERHEATING .....	9-4
<b>OVER COOLING</b> .....	9-4
COOLING SYSTEM .....	9-4
<b>FAULTY BRAKE</b> .....	9-4
POOR BRAKING EFFECT .....	9-4
<b>SHOCK ABSORBER MALFUNCTION</b> .....	9-5
MALFUNCTION .....	9-5
<b>UNSTABLE HANDLING</b> .....	9-5
UNSTABLE HANDLING .....	9-5
<b>LIGHTING SYSTEM</b> .....	9-5
HEADLIGHT DARK .....	9-5
BULB BURNT OUT .....	9-5

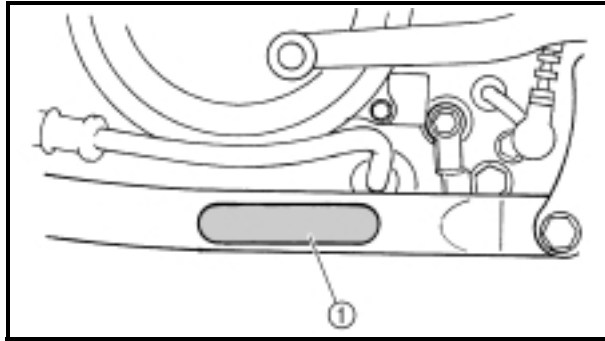

**GENERAL INFORMATION**  
**MACHINE IDENTIFICATION**

**VEHICLE IDENTIFICATION NUMBER**

The vehicle identification number ① is stamped into the left side of the frame.

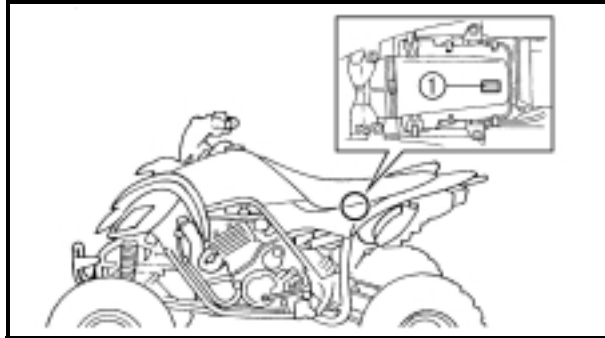

**MODEL LABEL**

The model label ① is affixed to the air filter case cover. This information will be needed to order spare parts.

EB101000

## **IMPORTANT INFORMATION PREPARATION FOR REMOVAL PROCEDURES**

1. Remove all dirt, mud, dust and foreign material before removal and disassembly.
2. Use proper tools and cleaning equipment. Refer to the "SPECIAL TOOLS" section.
3. When disassembling the machine, always keep mated parts together. This includes gears, cylinder, piston and other parts that have been "mated" through normal wear. Mated parts must always be reused or replaced as an assembly.
4. During machine disassembly, clean all parts and place them in trays in the order of disassembly. This will speed up assembly and allow for the correct installation of all parts.
5. Keep all parts away from any source of fire.

EB101010

## **REPLACEMENT PARTS**

1. Use only genuine Yamaha parts for all replacements. Use oil and grease recommended by Yamaha for all lubrication jobs. Other brands may be similar in function and appearance, but inferior in quality.

EB101020

## **GASKETS, OIL SEALS AND O-RINGS**

1. Replace all gaskets, seals and O-rings when overhauling the engine. All gasket surfaces, oil seal lips and O-rings must be cleaned.
2. Properly oil all mating parts and bearings during reassembly. Apply grease to the oil seal lips.



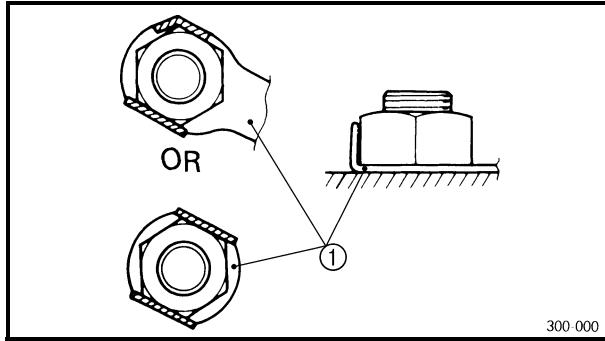

EB101030

**LOCK WASHERS/PLATES AND COTTER PINS**

1. Replace all lock washers/plates ① and cotter pins after removal. Bend lock tabs along the bolt or nut flats after the bolt or nut has been tightened to specification.

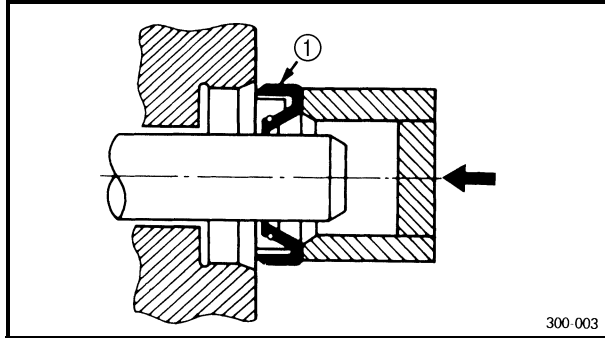

EB101040

**BEARINGS AND OIL SEALS**

1. Install bearings and oil seals so that the manufacturer's marks or numbers are visible. When installing oil seals, apply a light coating of lightweight lithium base grease to the seal lips. Oil bearings liberally when installing, if appropriate.

- ① Oil seal

**CAUTION:**

**Do not use compressed air to spin the bearings dry. This will damage the bearing surfaces.**

- ① Bearing

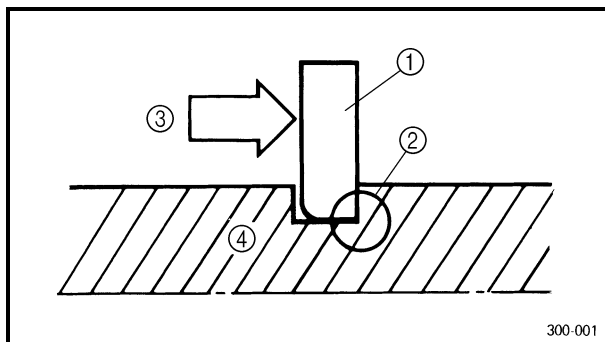
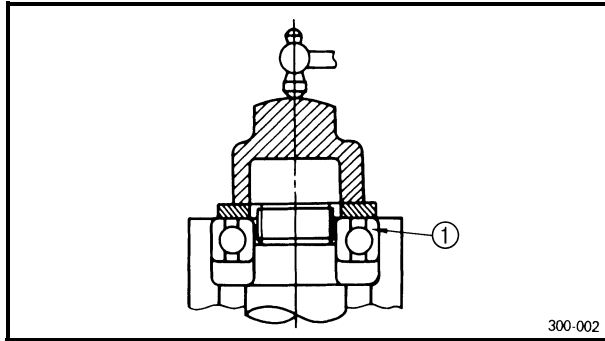

EB101050

**CIRCLIPS**

1. Check all circlips carefully before reassembly. Always replace piston pin clips after one use. Replace distorted circlips. When installing a circlip ①, make sure that the sharp-edged corner ② is positioned opposite the thrust ③ it receives. See sectional view.

- ④ Shaft

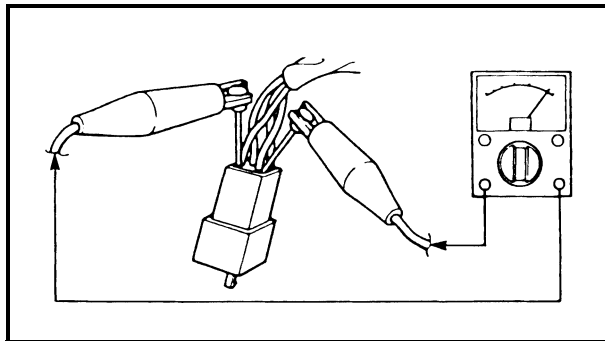
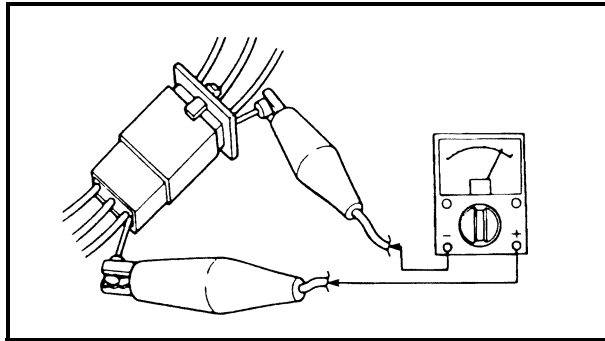
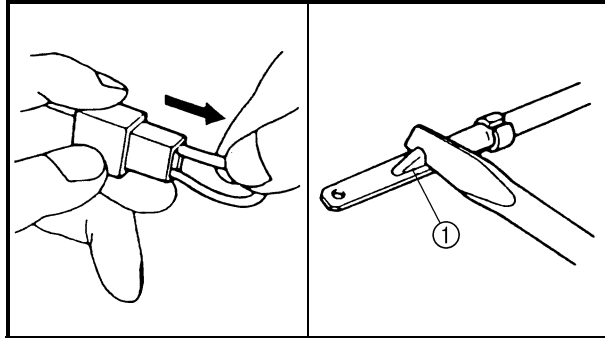
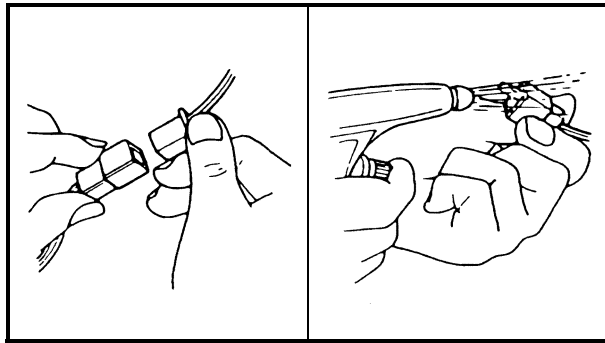

EB801000

## CHECKING OF CONNECTIONS

Check the connectors for stains, rust, moisture, etc.

### 1. Disconnect:

- Connector

### 2. Check:

- Connector

Moisture → Dry each terminal with an air blower.

Stains/rust → Connect and disconnect the terminals several times.

### 3. Check:

- Connector leads

Looseness → Bend up the pin ① and connect the terminals.

### 4. Connect:

- Connector terminals

### NOTE:

The two terminals “click” together.

### 5. Check:

- Continuity (using a pocket tester)

### NOTE:

- If there is no continuity, clean the terminals.
- When checking the wire harness be sure to perform steps 1 to 3.
- As a quick remedy, use a contact revitalizer available at most part stores.
- Check the connector with a pocket tester as shown.

EB102001

**SPECIAL TOOLS**

The following special tools are necessary for complete and accurate tune-up and assembly. Use only the appropriate special tools; this will help prevent damage caused by the use of inappropriate tools or improvised techniques. Special tools may differ by shape and part number from country to country. In such a case, two types are provided.

When placing an order, refer to the list provided below to avoid any mistakes.



For US and CDN

P/N. YM-, YU-, YS-, YK-, ACC-

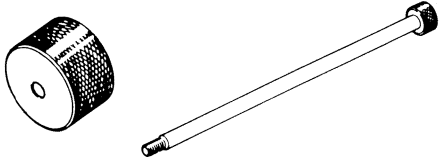
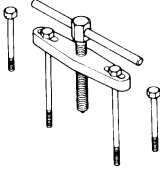
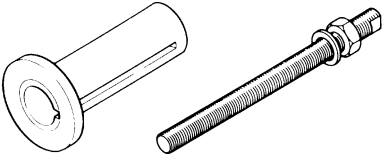
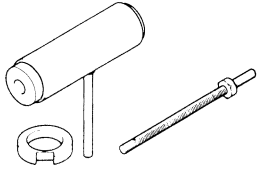
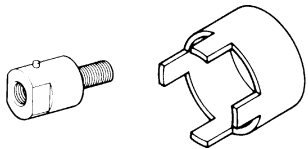
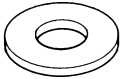

Except for US and CDN

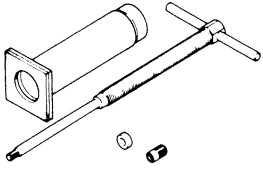
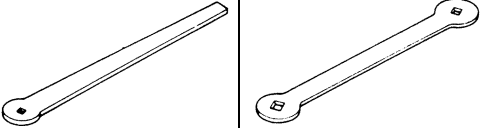
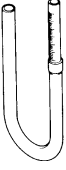
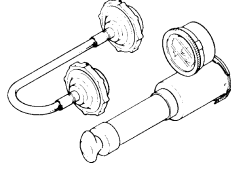
P/N. 90890-

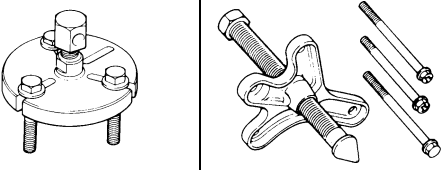
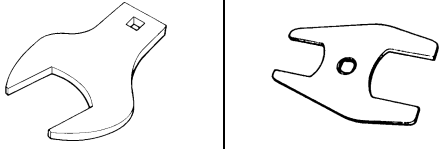
Tool No.	Tool name/How to use	Illustration
Bolt 90890-01083 Weight 90890-01084 Set YU-01083-A	Slide hammer bolt (M6)/weight/set  These tools are used to remove the rocker arm shaft.	
90890-01135 YU-01135-A	Crankcase separating tool  This tool is used to separate the crankcase.	
Pot 90890-01274 Bolt 90890-01275	Crankshaft installer pot Crankshaft installer bolt  These tools are used to install the crankshaft.	
YU-90050	Crankshaft installer set  These tools are used to install the crankshaft.	
Adapter 90890-04059 YM-90069 Spacer 90890-04081 YM-91044	Adapter Spacer (crankshaft installer)  These tools are used to install the crankshaft.	
90890-01016	Spacer  This tool is used to install the crankshaft.	

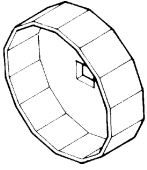
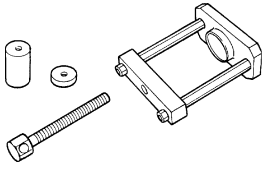
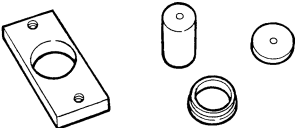
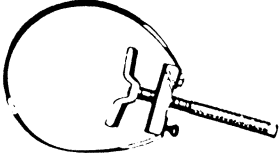
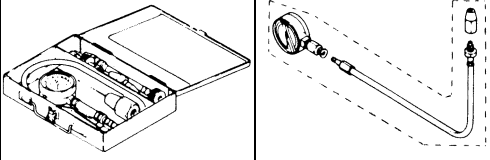
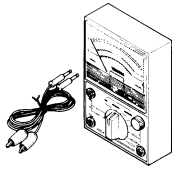
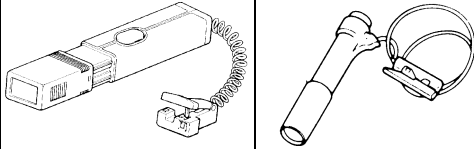
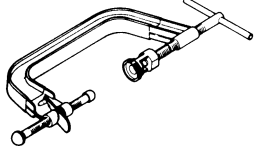
Tool No.	Tool name/How to use	Illustration
90890-01304 YU-01304	Piston pin puller  This tool is used to remove the piston pin.	
90890-01311 YM-08035	Tappet adjusting tool (3 mm)  This tool is necessary for adjusting the valve clearance.	
90890-01312 YM-01312-A	Fuel level gauge  This gauge is used to measure the fuel level in the float chamber.	
90890-01325 YU-24460-01	Radiator cap tester  This tool is used to check the cooling system.	
90890-01352 YU-33984	Adapter  This tool is used to check the cooling system.	
90890-01327 YM-01327	Damper rod holder (30 mm)  This tool is needed to loosen and tighten the steering stem bearing retainer.	
90890-01362 YU-33270	Flywheel puller  These tools are needed to remove the rotor.	
90890-01419 YM-37132	Axle nut wrench (50 mm)  This tool is needed to loosen or tighten the rear axle nut.	

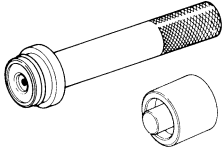
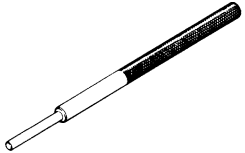
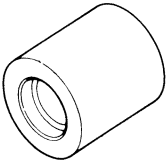
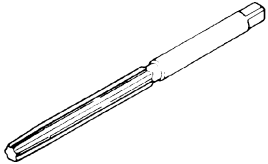
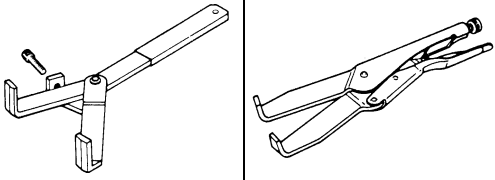
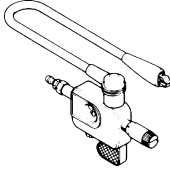
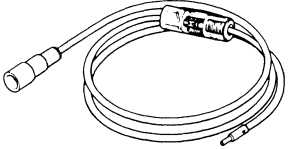
Tool No.	Tool name/How to use	Illustration
90890-01469 YM-01469	<p>Oil filter wrench</p> <p>This tool is needed to loosen or tighten the oil filter cartridge.</p>	
90890-01474 YM-01474	<p>Ball joint remover/installer set</p> <p>These tools are used to removing or installing the ball joint.</p>	
90890-01480 YM-01480	<p>Ball joint remover/installer attachment set</p> <p>These tools are used to removing or installing the ball joint.</p>	
90890-01701 YS-01880	<p>Sheave holder</p> <p>This tool is needed to hold the AC magneto rotor when removing or installing the AC magneto rotor bolts.</p>	
<p>Set 90890-03081 YU-33223 Adapter 90890-04082 YU-33223-3</p>	<p>Compression gauge set Adapter</p> <p>These tools are needed to measure engine compression.</p>	
90890-03112 YU-03112	<p>Pocket tester</p> <p>This instrument is needed for checking the electrical system.</p>	
90890-03141 YM-33277-A	<p>Timing light</p> <p>This tool is necessary for checking ignition timing.</p>	
<p>Compressor 90890-04019 YM-04019 Attachment 90890-01243</p>	<p>Valve spring compressor Valve spring compressor attachment</p> <p>This tool is needed to remove and install the valve assemblies.</p>	

Tool No.	Tool name/How to use	Illustration
Middle driven shaft bearing driver 90890-04058 YM-04058-1 Mechanical seal installer 90890-04078 YM-33221	Middle driven shaft bearing driver Mechanical seal installer  These tools are used to install the water pump seal.	
90890-04064 YM-4064-A	Valve guide remover (ø 6)  This tool is needed to remove and install the valve guide.	
90890-04065 YM-04065-A	Valve guide installer (ø 6)  This tool is needed to install the valve guide.	
90890-04066 YM-04066	Valve guide reamer (ø 6)  This tool is needed to rebores the new valve guide.	
90890-04086 YM-91042	Clutch holding tool  This tool is needed to hold the clutch carrier when removing or installing the carrier nut.	
90890-06754	Ignition checker  This instrument is necessary for checking the ignition system components.	
YM-34487	Dynamic spark tester  This instrument is necessary for checking the ignition system components.	
Bond 90890-85505 Sealant ACC-11001-05-01	Yamaha bond No. 1215 Sealant (Quick Gasket®)  This sealant (bond) is used on crankcase mating surfaces, etc.	



**SPECIFICATIONS**

**GENERAL SPECIFICATIONS**

Item	Standard
Model code:	5LP1 : (Except for California) 5LP3 : (For California)
Dimensions:	
Overall length	1,830 mm (72.0 in)
Overall width	1,100 mm (43.3 in)
Overall height	1,150 mm (45.3 in)
Seat height	860 mm (33.9 in)
Wheelbase	1,245 mm (49.0 in)
Minimum ground clearance	265 mm (10.4 in)
Minimum turning radius	3,300 mm (129.9 in)
Basic weight:	
With oil and full fuel tank	193 kg (426 lb)
Engine:	
Engine type	Liquid-cooled 4-stroke, SOHC
Cylinder arrangement	Forward-inclined single cylinder
Displacement	660 cm <sup>3</sup>
Bore × stroke	100.0 × 84.0 mm (3.94 × 3.31 in)
Compression ratio	9.2 : 1
Standard compression pressure (at sea level)	1,250 kPa (12.5 kg/cm <sup>2</sup> , 181 psi)
Starting system	Electric starter
Lubrication system:	Dry sump
Oil type or grade:	
Engine oil	
	API service SE, SF, SG type or higher
Oil capacity:	
Engine oil	
Periodic oil change	1.9 L (1.67 Imp qt, 2.01 US qt)
With oil filter replacement	1.95 L (1.72 Imp qt, 2.06 US qt)
Total amount	2.3 L (2.02 Imp qt, 2.43 US qt)
Radiator capacity (including all routes)	1.3 L (1.14 Imp qt, 1.37 US qt)
Air filter:	Wet type element
Fuel:	
Type	Unleaded fuel
Fuel tank capacity	12 L (2.64 Imp gal, 3.17 US gal)
Fuel reserve amount	2.6 L (0.57 Imp gal, 0.69 US gal)

# GENERAL SPECIFICATIONS

## SPEC



Item	Standard
Carburetor: Type/quantity Manufacturer	BSR33/2 MIKUNI
Spark plug: Type/manufacturer Spark plug gap	DPR8EA-9/NGK 0.8 ~ 0.9 mm (0.031 ~ 0.035 in)
Clutch type:	Wet, multiple disc
Transmission: Primary reduction system Primary reduction ratio Secondary reduction system Secondary reduction ratio Transmission type  Operation Gear ratio 1st gear 2nd gear 3rd gear 4th gear 5th gear Reverse gear	Spur gear 71/34 (2.088) Chain drive 40/13 (3.076) Constant mesh, 5-speed/forward. 1-speed/reverse Left foot operation           34/14 (2.428) 29/19 (1.526) 26/21 (1.238) 22/21 (1.047) 19/21 (0.904) 28/23 × 23 × 16 (1.750)
Chassis: Frame type Caster angle Camber angle Kingpin angle Kingpin offset Trail Tread (STD)                      front rear Toe-in	Steel tube frame 8° -1° 14.5° 5 mm (0.20 in) 47 mm (1.85 in) 925 mm (36.42 in) 840 mm (33.07 in) 0 ~ 10 mm (0 ~ 0.39 in)
Tire: Type Size                                  front rear Manufacturer                      front rear Type                                   front rear	Tubeless AT21 × 7-10 AT20 × 10-9 DUNLOP DUNLOP KT331 Radial KT335 Radial



# GENERAL SPECIFICATIONS

**SPEC**



Item	Standard								
Tire pressure (cold tire): Maximum load* Off-road riding <table style="margin-left: 200px; border: none;"> <tr> <td style="padding-right: 20px;">front</td> <td></td> </tr> <tr> <td>rear</td> <td></td> </tr> </table> *Load in total weight of cargo, rider and accessories	front		rear		100 kg (220 lb) 27.5 kPa (0.275 kg/cm <sup>2</sup> , 4.0 psi) 27.5 kPa (0.275 kg/cm <sup>2</sup> , 4.0 psi)				
front									
rear									
Brake: Front brake <table style="margin-left: 150px; border: none;"> <tr> <td style="padding-right: 20px;">type</td> <td></td> </tr> <tr> <td>operation</td> <td></td> </tr> </table> Rear brake <table style="margin-left: 150px; border: none;"> <tr> <td style="padding-right: 20px;">type</td> <td></td> </tr> <tr> <td>operation</td> <td></td> </tr> </table>	type		operation		type		operation		Dual disc brake Right hand operation Single disc brake Right foot operation
type									
operation									
type									
operation									
Suspension: Front suspension Rear suspension	Double wishbone Swingarm (link suspension)								
Shock absorber: Front shock absorber Rear shock absorber	Coil spring/oil damper Coil spring/gas-oil damper								
Wheel travel: Front wheel travel Rear wheel travel	230 mm (9.06 in) 220 mm (8.66 in)								
Electrical: Ignition system Generator system Battery type Battery capacity	DC-C.D.I. A.C. magneto YTX14-BS 12 V 12 Ah								
Headlight type:	Krypton bulb								
Bulb voltage/wattage × quantity: Headlight Tail/brake light Indicator and warning lights <table style="margin-left: 200px; border: none;"> <tr> <td style="padding-right: 20px;">Neutral</td> <td></td> </tr> <tr> <td>Reverse</td> <td></td> </tr> <tr> <td>Coolant temperature</td> <td></td> </tr> </table>	Neutral		Reverse		Coolant temperature		12 V 30 W/30 W × 2 12 V 5 W/21 W × 1 12 V 1.7 W × 1 12 V 1.7 W × 1 12 V 1.7 W × 1		
Neutral									
Reverse									
Coolant temperature									

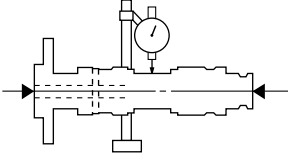
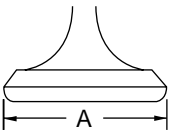
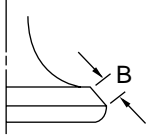
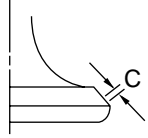
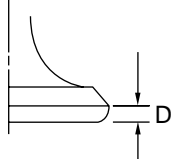

Item	Standard	Limit
Camshaft runout limit 	----	0.03 mm (0.0012 in)
Timing chain: Timing chain type/No. of links Timing chain adjustment method	75-RH2015/126 Automatic	---- ----
Rocker arm/rocker arm shaft: Shaft outside diameter Arm-to-shaft clearance	11.976 ~ 11.991 mm (0.4715 ~ 0.4721 in) 0.009 ~ 0.042 mm (0.0004 ~ 0.0017 in)	---- ----
Valve, valve seat, valve guide: Valve clearance (cold)	IN 0.10 ~ 0.15 mm (0.0039 ~ 0.0059 in) EX 0.15 ~ 0.20 mm (0.0059 ~ 0.0079 in)	---- ----
Valve dimensions    		
Head Diameter "A" head diameter	IN 29.9 ~ 30.1 mm (1.1772 ~ 1.1850 in) EX 31.9 ~ 32.1 mm (1.2559 ~ 1.2638 in)	---- ----
"B" face width	IN 2.25 mm (0.0886 in) EX 2.26 mm (0.0890 in)	---- ----
"C" seat width	IN 0.9 ~ 1.1 mm (0.0354 ~ 0.0433 in) EX 0.9 ~ 1.1 mm (0.0354 ~ 0.0433 in)	1.6 mm (0.0630 in) 1.6 mm (0.0630 in)
"D" margin thickness	IN 0.85 ~ 1.15 mm (0.0335 ~ 0.0453 in) EX 0.85 ~ 1.15 mm (0.0335 ~ 0.0453 in)	---- ----
Stem outside diameter	IN 5.975 ~ 5.990 mm (0.2352 ~ 0.2358 in) EX 5.960 ~ 5.975 mm (0.2346 ~ 0.2352 in)	5.945 mm (0.2341 in) 5.930 mm (0.2335 in)
Guide inside diameter	IN 6.000 ~ 6.012 mm (0.2362 ~ 0.2367 in) EX 6.000 ~ 6.012 mm (0.2362 ~ 0.2367 in)	6.040 mm (0.2378 in) 6.040 mm (0.2378 in)



Item		Standard	Limit
Stem-to-guide clearance	IN	0.010 ~ 0.037 mm (0.0004 ~ 0.0015 in)	0.08 mm (0.0031 in)
	EX	0.025 ~ 0.052 mm (0.0010 ~ 0.0020 in)	0.10 mm (0.0039 in)
Stem runout limit		----	0.01 mm (0.0004 in)
Valve seat width	IN	0.9 ~ 1.1 mm (0.0354 ~ 0.0433 in)	1.6 mm (0.0630 in)
	EX	0.9 ~ 1.1 mm (0.0354 ~ 0.0433 in)	1.6 mm (0.0630 in)
Valve spring:			
Free length	IN	35.95 mm (1.42 in)	34.15 mm (1.34 in)
	EX	37.75 mm (1.49 in)	35.86 mm (1.41 in)
Set length (valve closed)	IN	27.2 mm (1.07 in)	----
	EX	30.7 mm (1.21 in)	----
Compressed pressure (installed)	IN	149 ~ 173 N (15.19 ~ 17.64 kg, 33.50 ~ 38.89 lb)	----
	EX	165 ~ 191 N (16.83 ~ 19.49 kg, 37.09 ~ 42.94 lb)	----
Tilt limit *	IN		2.5°/1.6 mm (2.5°/0.06 in)
	EX		2.5°/1.6 mm (2.5°/0.06 in)
Direction of winding (top view)	IN	Clockwise	----
	EX	Clockwise	----

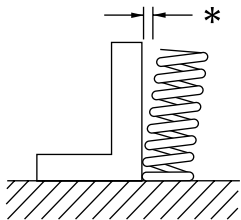
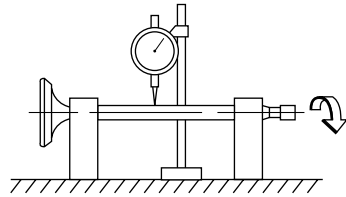

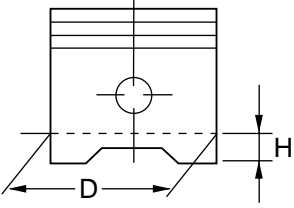
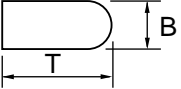
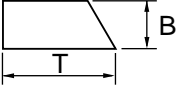
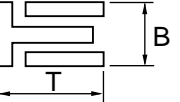
Item	Standard	Limit
<p>Piston:</p> <p>Piston to cylinder clearance</p> <p>Piston size "D"</p>  <p>Measuring point "H"</p> <p>Piston off-set</p> <p>Piston pin bore inside diameter</p> <p>Piston pin outside diameter</p>	<p>0.05 ~ 0.07 mm (0.0020 ~ 0.0028 in)</p> <p>99.945 ~ 99.995 mm (3.9348 ~ 3.9368 in)</p> <p>2.5 mm (0.10 in)</p> <p>1.0 mm (0.04 in)</p> <p>22.004 ~ 22.015 mm (0.8663 ~ 0.8667 in)</p> <p>21.991 ~ 22.000 mm (0.8658 ~ 0.8661 in)</p>	<p>0.15 mm (0.0059 in)</p> <p>----</p> <p>----</p> <p>22.045 mm (0.8679 in)</p> <p>21.971 mm (0.8650 in)</p>
<p>Piston rings:</p> <p>Top ring</p>  <p>Type</p> <p>Dimensions (B × T)</p> <p>End gap (installed)</p> <p>Side clearance (installed)</p> <p>2nd ring</p>  <p>Type</p> <p>Dimensions (B × T)</p> <p>End gap (installed)</p> <p>Side clearance</p> <p>Oil ring</p>  <p>Dimensions (B × T)</p> <p>End gap (installed)</p>	<p>Barrel</p> <p>1.2 × 3.8 mm (0.0472 × 0.1496 in)</p> <p>0.30 ~ 0.45 mm (0.0118 ~ 0.0177 in)</p> <p>0.04 ~ 0.08 mm (0.0016 ~ 0.0031 in)</p> <p>Taper</p> <p>1.2 × 4.0 mm (0.0472 × 0.1575 in)</p> <p>0.30 ~ 0.45 mm (0.0118 ~ 0.0177 in)</p> <p>0.03 ~ 0.07 mm (0.0012 ~ 0.0028 in)</p> <p>2.5 × 3.4 mm (0.0984 × 0.1339 in)</p> <p>0.2 ~ 0.7 mm (0.0079 ~ 0.0276 in)</p>	<p>----</p> <p>----</p> <p>0.70 mm (0.0276 in)</p> <p>0.13 mm (0.0051 in)</p> <p>----</p> <p>----</p> <p>0.80 mm (0.0315 in)</p> <p>0.13 mm (0.0051 in)</p> <p>----</p> <p>----</p>

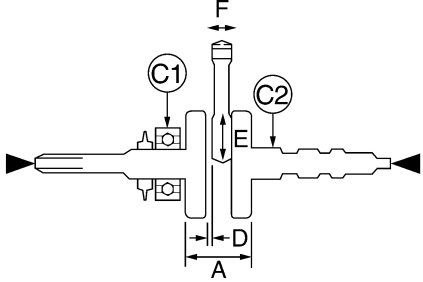
Item	Standard	Limit
<p>Crankshaft:</p>  <p>Crank width "A"</p> <p>Runout limit C1</p> <p>C2</p> <p>Big end side clearance "D"</p> <p>Big end radial clearance "E"</p> <p>Small end free play "F"</p>	<p>74.95 ~ 75.00 mm (2.9508 ~ 2.9528 in)</p> <p>----</p> <p>----</p> <p>0.32 ~ 0.64 mm (0.0126 ~ 0.0252 in)</p> <p>0.010 ~ 0.025 mm (0.0004 ~ 0.0010 in)</p> <p>0.8 mm (0.0315 in)</p>	<p>----</p> <p>0.03 mm (0.0012 in)</p> <p>0.03 mm (0.0012 in)</p> <p>1.0 mm (0.0394 in)</p> <p>----</p> <p>----</p>
<p>Balancer:</p> <p>Balancer drive method</p>	<p>Gear</p>	<p>----</p>
<p>Clutch:</p> <p>Friction plate 1</p> <p>Thickness</p> <p>Quantity</p> <p>Friction plate 2</p> <p>Thickness</p> <p>Quantity</p> <p>Clutch plate</p> <p>Thickness</p> <p>Quantity</p> <p>Max. warpage</p> <p>Clutch spring</p> <p>Free length</p> <p>Quantity</p> <p>Min. length</p> <p>Clutch release method</p>	<p>2.74 ~ 2.86 mm (0.108 ~ 0.113 in)</p> <p>6</p> <p>2.94 ~ 3.06 mm (0.116 ~ 0.120 in)</p> <p>2</p> <p>1.1 ~ 1.3 mm (0.043 ~ 0.051 in)</p> <p>7</p> <p>----</p> <p>42.8 mm (1.69 in)</p> <p>5</p> <p>----</p> <p>Outer pull, rack and pinion pull</p>	<p>2.6 mm (0.102 in)</p> <p>----</p> <p>2.8 mm (0.110 in)</p> <p>----</p> <p>----</p> <p>0.2 mm (0.008 in)</p> <p>40.7 mm (1.60 in)</p> <p>----</p> <p>40.8 mm (1.61 in)</p> <p>----</p>

# MAINTENANCE SPECIFICATIONS

**SPEC**



Item	Standard	Limit
<b>Transmission:</b>		
Main axle deflection limit	----	0.08 mm (0.0031 in)
Drive axle deflection limit	----	0.08 mm (0.0031 in)
<b>Shifter:</b>		
Shifter type	Shift drum and guide bar	----
<b>Decompression device:</b>		
Device type	Auto decomp	----
<b>Air filter oil grade:</b>		
	Engine oil	----
<b>Carburetors:</b>		
I. D. mark		----
Main jet (M.J)	5LP1 00 Carburetor #1 : #140 Carburetor #2 : #145	----
Main air jet (M.A.J)	#130	----
Jet needle (J.N)	5ND16-56-3	----
Needle jet (N.J)	P-6M (#826)	----
Pilot air jet (P.A.J.1)	Carburetor #1 : #80 Carburetor #2 : #150	----
Pilot air jet (P.A.J.2)	1.3	----
Pilot outlet (P.O)	Carburetor #1 : 1.0 Carburetor #2 : 0.9	----
Pilot jet (P.J)	#22.5	----
Bypass 1 (B.P.1)	0.8	----
Bypass 2 (B.P.2)	0.8	----
Valve seat size (V.S)	2.0	----
Starter jet (G.S.1)	#95	----
Starter jet (G.S.2)	0.5	----
Throttle valve size (Th.V)	#80	----
Float height (F.H)	13 mm (0.51 in)	----
Fuel level (F.L)	3 ~ 4 mm (0.12 ~ 0.16 in)	----
Engine idle speed	1,450 ~ 1,550 r/min	----
Intake vacuum	32.0 ~ 33.3 kPa (240 ~ 250 mmHg, 9.45 ~ 9.83 inHg)	----
<b>Oil pump:</b>		
Oil filter type	Paper	----
Oil pump type	Trochoid	----
Tip clearance "A" or "B"	0.12 mm (0.005 in)	0.2 mm (0.008 in)
Side clearance	0.03 ~ 0.08 mm (0.001 ~ 0.003 in)	----
Bypass valve setting pressure	80 ~ 120 kPa (0.8 ~ 1.2 kg/cm <sup>2</sup> , 11.6 ~ 17.4 psi)	----
Oil pressure (hot)	65 kPa (0.65 kg/cm <sup>2</sup> , 9.4 psi) at 1,500 r/min	----
Pressure check location	Cylinder head	----



Item	Standard	Limit
<b>Cooling system:</b>		
Radiator core		
Width	219 mm (8.62 in)	----
Height	300 mm (11.8 in)	----
Depth	16 mm (0.63 in)	----
Radiator cap opening pressure	95 ~ 125 kPa (0.95 ~ 1.25 kg/cm <sup>2</sup> , 13.8 ~ 18.1 psi)	----
Radiator capacity	0.55 L (0.48 Imp qt, 0.58 US qt)	----
Coolant reservoir		
Capacity	0.29 L (0.26 Imp qt, 0.31 US qt)	----
From low to full level	0.165 L (0.15 Imp qt, 0.17 US qt)	----
<b>Water pump:</b>		
Type	Single suction centrifugal pump	----
Reduction ratio	33/34 (0.971)	----

**Lubrication chart:**

- Pressure feed
- Splashed scavenge

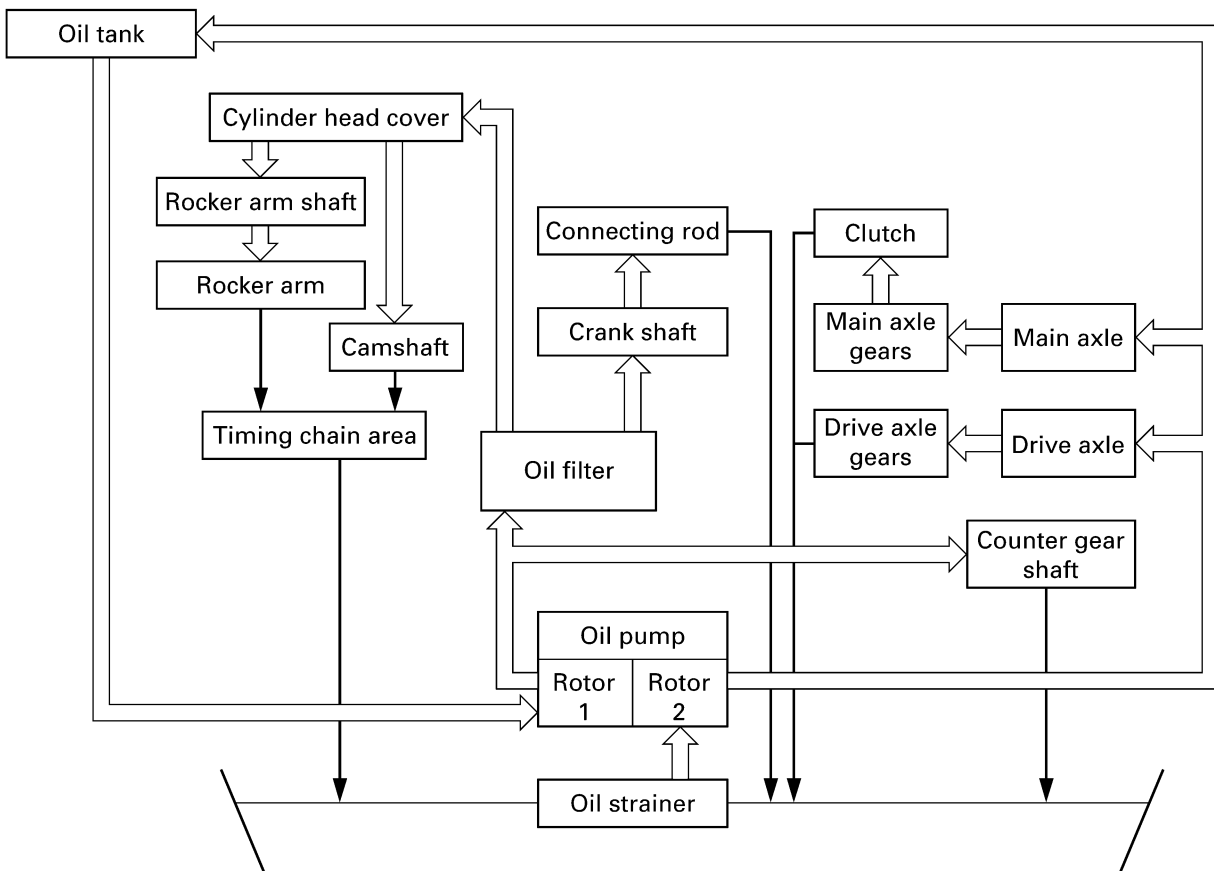





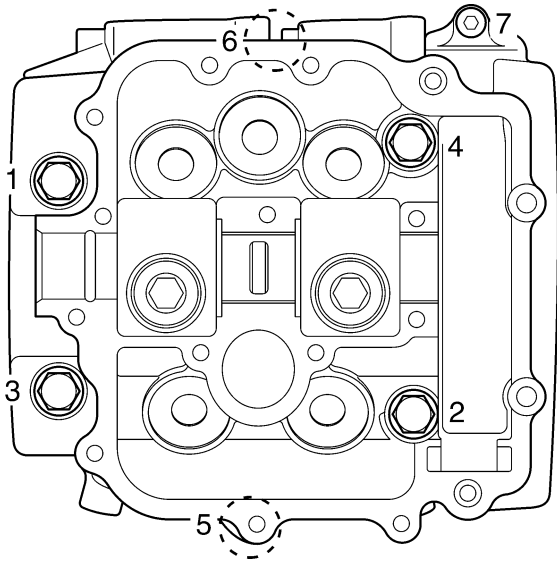

Item	Standard	Limit
<p>Cylinder head tightening sequence:</p> 		



**Tightening torques**

Part to be tightened	Part name	Thread size	Q'ty	Tightening torque			Remarks
				Nm	m·kg	ft·lb	
Cylinder head (exhaust pipe)	Stud bolt	M6	4	7	0.7	5.1	
Cylinder head	Bolt	M9	4	38	3.8	27	
	Bolt	M9	2	38	3.8	27	
	Bolt	M6	1	10	1.0	7.2	
	Bolt	M6	1	10	1.0	7.2	
Spark plug	—	M12	1	18	1.8	13	
Cylinder head cover	Bolt	M6	17	10	1.0	7.2	
Camshaft end cap	Bolt	M6	1	10	1.0	7.2	
Oil check bolt	—	M6	1	7	0.7	5.1	
Tappet cover (exhaust)	—	M32	2	12	1.2	8.7	
Tappet cover (intake)	Bolt	M6	4	10	1.0	7.2	
Cylinder	Bolt	M10	2	42	4.2	30	
	Bolt	M10	2	42	4.2	30	
	Bolt	M6	2	10	1.0	7.2	
Timing chain tensioner	Bolt	M6	2	10	1.0	7.2	
Timing chain tensioner cap	Bolt	M16	1	22	2.2	16	
Timing chain guide (intake)	Bolt	M6	2	8	0.8	5.8	
Camshaft sprocket	Bolt	M7	2	20	2.0	14	
Rocker arm shaft	Bolt	M6	2	10	1.0	7.2	
Valve adjusting screw	Nut	M6	5	14	1.4	10	
Radiator	Bolt	M6	2	7	0.7	5.1	
Coolant drain bolt	—	M6	1	10	1.0	7.2	
Engine oil drain bolt (oil tank)	—	M10	1	25	2.5	18	
Engine oil drain bolt (engine)	—	M14	1	30	3.0	22	
Oil filter bolt	Union bolt	M20	1	63	6.3	45	
Oil filter cartridge	—	M20	1	17	1.7	12	
Oil delivery pipe 1	Union bolt	M10	2	20	2.0	14	
Oil delivery pipe 2	Union bolt	M8	2	18	1.8	13	
Oil pipe joint	—	M14	1	50	5.0	36	
Oil pipe 1 and oil pipe joint	Nut	M16	1	35	3.5	25	
Oil pipe 2 and oil tank	Nut	M16	1	35	3.5	25	
Air filter case	Bolt	M6	2	7	0.7	5.1	
Carburetor clamp	Bolt	M4	4	5	0.5	3.6	
Exhaust pipe 1 and exhaust pipe 2	Bolt	M8	1	16	1.6	12	
Exhaust pipe protector	Bolt	M6	4	10	1.0	7.2	
Spark arrester	Bolt	M6	1	8	0.8	5.8	
Muffler and exhaust pipe 2	Bolt	M8	1	20	2.0	14	
Muffler	Bolt	M8	2	26	2.6	19	
Silencer cap	Bolt	M6	3	10	1.0	7.2	
Exhaust pipe	Nut	M6	4	10	1.0	7.2	

# MAINTENANCE SPECIFICATIONS

## SPEC



Part to be tightened	Part name	Thread size	Q'ty	Tightening torque			Remarks
				Nm	m·kg	ft·lb	
Bearing retainer	Screw	M6	4	7	0.7	5.1	
AC magneto rotor	Nut	M14	1	150	15.0	110	
Starter clutch	Bolt	M6	6	16	1.6	11	
Balancer driven gear	Nut	M18	1	140	14.0	100	 Use a lock washer.
Primary drive gear	Nut	M20	1	150	15.0	110	 Use a lock washer.
Clutch spring	Bolt	M6	5	8	0.8	5.8	
Clutch boss	Nut	M20	1	90	9.0	65	Use a lock washer.
Pull lever shaft	Bolt	M6	1	7	0.7	5.1	
Drive sprocket	Nut	M18	1	70	7.0	50	Use a lock washer.
Oil seal retainer	Bolt	M6	2	10	1.0	7.2	
Shift drum segment	Bolt	M8	1	30	3.0	22	
Shift guide	Bolt	M6	2	10	1.0	7.2	
Stopper lever	Bolt	M6	1	10	1.0	7.2	
Reverse shift lever	Bolt	M6	1	13	1.3	9.4	
Shift arm	Bolt	M6	1	10	1.0	7.2	
Shift pedal adjusting rod	Nut	M6	1	8	0.8	5.8	Left-hand threads
	Nut	M6	1	8	0.8	5.8	
Stator assembly	Bolt	M5	3	7	0.7	5.1	
Pick up coil	Bolt	M5	2	7	0.7	5.1	
AC magneto lead holder	Bolt	M6	2	10	1.0	7.2	
Ignition coil	Bolt	M6	2	7	0.7	5.1	
Starter motor	Bolt	M6	2	10	1.0	7.2	
Neutral switch	—	M10	1	20	2.0	14	
Reverse switch	—	M10	1	20	2.0	14	
Thermo switch 1	—	M18	1	28	2.8	20	
Thermo switch 2	—	M18	1	28	2.8	20	

**CHASSIS**

Item	Standard	Limit
Steering system: Steering bearing type	Ball and race bearing	----
Front suspension: Shock absorber travel	110 mm (4.33 in)	----
Fork spring free length	316.5 mm (12.46 in)	----
Spring fitting length	293.5 mm (11.56 in)	----
Spring rate (K1)	19.6 N/mm (2.00 kg/mm, 111.92 lb/in)	----
Spring rate (K2)	29.4 N/mm (3.00 kg/mm, 167.87 lb/in)	----
Optional spring	No	----
Rear suspension: Shock absorber travel	100 mm (3.94 in)	----
Spring free length	273 mm (10.75 in)	----
Spring fitting length	253 mm (9.96 in)	----
Spring rate (K1)	55 N/mm (5.61 kg/mm, 314.05 lb/in)	----
Stroke (K1)	0 ~ 100 mm (0 ~ 3.94 in)	----
Optional spring	No	----
Swingarm: Free play limit	end side	1 mm (0.04 in) 1 mm (0.04 in)
Front wheel: Type	Panel wheel	----
Rim size	10 × 5.5 AT	----
Rim material	Aluminum	----
Rim runout limit	radial	2 mm (0.08 in)
	lateral	2 mm (0.08 in)
Rear wheel: Type	Panel wheel	----
Rim size	9 × 8.5 AT	----
Rim material	Aluminum	----
Rim runout limit	radial	2 mm (0.08 in)
	lateral	2 mm (0.08 in)



**Tightening torques**

Part to be tightened	Thread size	Tightening torque			Remarks
		Nm	m·kg	ft·lb	
Engine bracket (upper) and frame	M8	33	3.3	24	
Engine bracket (upper) and engine	M10	40	4.0	29	
Engine bracket (lower) and frame	M10	56	5.6	40	
Engine bracket (lower) and engine	M10	56	5.6	40	
Engine bracket (middle and lower) and engine	M10	56	5.6	40	
Swingarm pivot shaft, engine and frame	M16	95	9.5	68	
Rear shock absorber and frame	M10	32	3.2	23	
Relay arm and swingarm	M10	32	3.2	23	
Connecting arm and frame	M10	32	3.2	23	
Relay arm and rear shock absorber	M10	32	3.2	23	
Relay arm and connecting arm	M10	32	3.2	23	
Drive chain guide and swingarm	M6	7	0.7	5.1	
Hub, brake caliper bracket and swingarm	M12	90	9.0	65	
Drive chain adjusting bolt and locknut	M8	16	1.6	11	
Front shock absorber and frame	M10	45	4.5	32	
Front shock absorber and front arm (lower)	M10	45	4.5	32	
Front arm (upper) and frame	M10	38	3.8	27	
Front arm (lower) and frame	M10	32	3.2	23	
Brake hose holder and front arm (upper)	M6	7	0.7	5.1	
Steering stem, pitman arm and frame	M14	110	11	80	
Steering stem bushing and frame	M8	23	2.3	17	Use a lock washer.
Steering stem and handlebar holder	M8	23	2.3	17	
Tie-rod end and locknut	M10	15	1.5	11	
Steering knuckle and front wheel hub	M14	70	7.0	50	
Steering knuckle and front arm (upper and lower)	M10	25	2.5	18	
Steering knuckle and tie-rod ball joint	M10	25	2.5	18	
Pitman arm and tie-rod ball joint	M10	25	2.5	18	
Frame and bearing retainer	M42	40	4.0	29	
Fuel tank and fuel cock	M6	4	0.4	2.9	
Fuel tank and frame	M6	7	0.7	5.1	
Front wheel and front wheel hub	M10	45	4.5	32	
Steering knuckle and front brake caliper	M8	28	2.8	20	
Front brake disc and front wheel hub	M8	28	2.8	20	
Rear axle and rear wheel hub	M14	120	12	85	
Rear brake caliper and brake caliper bracket	M8	28	2.8	20	
Rear wheel and rear wheel hub	M10	45	4.5	32	
Driven sprocket and sprocket bracket	M8	24	2.4	17	
Front brake pipe nut	M10	19	1.9	13	
Front brake master cylinder and handlebar	M6	7	0.7	5.1	

Part to be tightened	Thread size	Tightening torque			Remarks
		Nm	m·kg	ft·lb	
Front brake master cylinder and brake lever	M6	6	0.6	4.3	Use a lock washer.
Front brake master cylinder and brake hose	M10	27	2.7	19	
Brake hose joint and frame	M6	10	1.0	7.2	
Bleed screw	M8	6	0.6	4.3	
Front brake pad holding bolt	M10	18	1.8	13	
Front brake caliper and brake hose	M10	27	2.7	19	
Front brake caliper retaining bolt	M8	23	2.3	17	
Rear axle ring nut	M38	SEE NOTE			
Rear brake pad holding bolt	M10	18	1.8	13	
Rear brake caliper and brake hose	M10	30	3.0	22	
Rear brake master cylinder and frame	M8	20	2.0	14	
Rear brake master cylinder and brake hose	M10	30	3.0	22	
Parking brake adjusting bolt and locknut	M8	16	1.6	11	
Rear brake disc and brake disc bracket	M8	28	2.8	20	
Rear brake fluid reservoir cover and bracket	M6	4	0.4	2.9	
Rear brake fluid reservoir and bracket	M6	4	0.4	2.9	
Brake hose holder and swingarm	M6	7	0.7	5.1	
Front bumper and frame	M8	31	3.1	22	
Front fender bracket and frame	M8	16	1.6	11	
Rear carrier bar and frame	M8	23	2.3	17	
Footrest and frame	M10	65	6.5	48	
Footrest guard bracket and frame	M8	33	3.3	24	
Footrest and footrest guard bracket	M8	16	1.6	11	
Footrest guard bracket and rear fender	M6	7	0.7	5.1	
Battery holding bracket and frame	M6	7	0.7	5.1	
Air filter case and frame	M6	7	0.7	5.1	
Carburetor clamp screw	M4	5	0.5	3.6	
Tail/brake light bracket and frame	M6	7	0.7	5.1	
Tail/brake light bracket and tail/brake light	M6	7	0.7	5.1	
Swingarm skid plate and swingarm	M6	7	0.7	5.1	
Swingarm skid plate and swingarm	M8	16	1.6	11	
Drive chain tensioner and frame	M8	32	3.2	23	
Engine skid plate and frame	M6	7	0.7	5.1	
Main frame and rear frame	M10	53	5.3	38	

**NOTE:**

Apply locking agent (LOCTITE®) to ring nuts threads.

1st: Tighten the inside ring nut 55 Nm (5.5 m • kg, 40 ft • lb).

2nd: Tighten the outside ring nut while holding the inside ring nut 190 Nm (19 m • kg, 140 ft • lb).

3rd: Loosen the inside ring nut while holding the outside ring nut 240 Nm (24 m • kg, 170 ft • lb).



**ELECTRICAL**

Item	Standard	Limit
Voltage:	12 V	----
Ignition system:		
Ignition timing (B.T.D.C.)	12°/ 1,500 r/min	----
Advancer type	Digital type	----
C.D.I.:		
Magneto model/manufacture	F4T260/MITSUBISHI	----
Pickup coil resistance/color	445 ~ 545 Ω at 20 °C (68 °F)/ White/Red – White/Green	----
Rotor rotation direction detection coil resistance/color	0.069 ~ 0.085 Ω at 20 °C (68 °F)/ Red – White/Blue	----
C.D.I. unit model/manufacture	F8T37971/MITSUBISHI	----
Ignition coil:		
Model/manufacture	2JN/YAMAHA	----
Minimum spark gap	6 mm (0.24 in)	----
Primary winding resistance	0.18 ~ 0.28 Ω at 20 °C (68 °F)	----
Secondary winding resistance	6.32 ~ 9.48 kΩ at 20 °C (68 °F)	----
Spark plug cap:		
Type	Resin type	----
Resistance	10 kΩ	----
Charging system:		
Type	A.C. magneto generator	----
Model/manufacture	F4T260/MITSUBISHI	----
Nominal output	14 V 16 A at 5,000 r/min	----
Charging coil resistance/color	0.43 ~ 0.65 Ω at 20 °C (68 °F)/ White – White	----
Rectifier:		
Type	Semi conductor-short circuit	----
Model/manufacture	SH640E-11/SHINDENGEN	----
No load voltage (DC)	14.1 ~ 14.9 V	----
Capacity	14 A	----
Withstand voltage	200 V	----
Electric starter system:		
Type	Constantmesh type	----
Starter motor		
Model/manufacture	SM-13/MITSUBA	----
Output	0.8 kW	----
Armature coil resistance	0.025 ~ 0.035 Ω at 20 °C (68 °F)	----
Brush overall length	12.5 mm (0.49 in)	5 mm (0.20 in)
Spring force	7.65 ~ 10.01 N (27.54 ~ 36.03 oz)	----
Commutator diameter	28 mm (1.10 in)	27 mm (1.06 in)
Mica undercut	0.7 mm (0.03 in)	----



# MAINTENANCE SPECIFICATIONS

**SPEC**



Item	Standard	Limit
Starter relay		
Model/manufacture	MS5F-721/JIDECO	----
Amperage rating	180 A	----
Coil winding resistance	4.18 ~ 4.62 Ω at 20 °C (68 °F)	----
Thermostat switch:		
Thermostat switch 1		
Model/manufacture	5GH/NIPPON THERMOSTAT	----
Thermostat switch 2		
Model/manufacture	5LP/NIPPON THERMOSTAT	----
Circuit breaker:		
Type	Fuse	----
Amperage for individual circuit		
Fuse	20 A × 1	----
Reserve	20 A × 1	----

EB201000

## HOW TO USE THE CONVERSION TABLE

All specification data in this manual are listed in SI and METRIC UNITS.

Use this table to convert METRIC unit data to IMPERIAL unit data.

Ex.

METRIC	MULTIPLIER	=	IMPERIAL
** mm	× 0.03937	=	** in
2 mm	× 0.03937	=	0.08 in

### CONVERSION TABLE

METRIC TO IMPERIAL			
	Metric unit	Multiplier	Imperial unit
Torque	m·kg	7.233	ft·lb
	m·kg	86.794	in·lb
	cm·kg	0.0723	ft·lb
	cm·kg	0.8679	in·lb
Weight	kg	2.205	lb
	g	0.03527	oz
Speed	km/hr	0.6214	mph
Distance	km	0.6214	mi
	m	3.281	ft
	m	1.094	yd
	cm	0.3937	in
	mm	0.03937	in
Volume/ Capacity	cc (cm <sup>3</sup> )	0.03527	oz (IMP liq.)
	cc (cm <sup>3</sup> )	0.06102	cu·in
	lt (liter)	0.8799	qt (IMP liq.)
	lt (liter)	0.2199	gal (IMP liq.)
Misc.	kg/mm	55.997	lb/in
	kg/cm <sup>2</sup>	14.2234	psi (lb/in <sup>2</sup> )
	Centigrade (°C)	9/5+32	Fahrenheit (°F)

EB202001

## GENERAL TORQUE SPECIFICATIONS

This chart specifies torque for standard fasteners with standard I.S.O. pitch threads. Torque specifications for special components or assemblies are provided for each chapter of this manual. To avoid warpage, tighten multi-fastener assemblies in a crisscross fashion, in progressive stages, until the specified torque is reached. Unless otherwise specified, torque specifications require clean, dry threads. Components should be at room temperature.

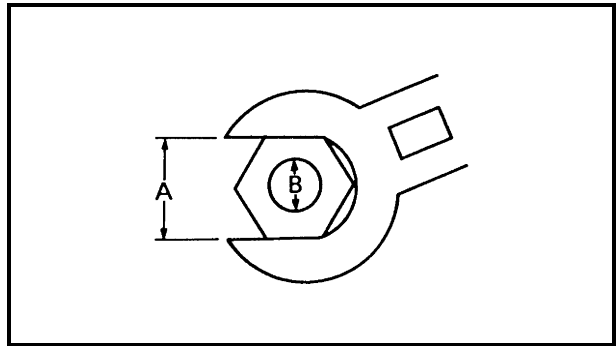

A: Distance between flats  
B: Outside thread diameter

A (nut)	B (bolt)	General torque specifications		
		Nm	m·kg	ft·lb
10 mm	6 mm	6	0.6	4.3
12 mm	8 mm	15	1.5	11
14 mm	10 mm	30	3.0	22
17 mm	12 mm	55	5.5	40
19 mm	14 mm	85	8.5	61
22 mm	16 mm	130	13.0	94



**LUBRICATION POINTS AND LUBRICANT TYPES**

**ENGINE**

Lubrication points	Lubricant type
Oil seal lips (all)	
O-ring (all)	
Bearings (all)	
Crank pin	
Connecting rod (bearing)	
Camshaft sprocket	
Crankshaft	
Piston surface/piston rings	
Piston pin	
Primary drive gear/primary driven gear	
Valve stem/valve stem end	
Rocker arm shaft	
Rocker arm	
Camshaft lobe/journal	
Oil pump shaft, rotor, housing	
Oil filter O-ring	
Starter idle gear/shaft	
Transmission gear (wheel/pinion)	
Axle (main/drive)	
Shift fork/guide bar	
Shift drum/shift shaft/shift cam stopper ball	
Shift lever/shift guide	
Crankcase mating surfaces	Sealant (Quick Gasket®) Yamaha bond No.1215
Cylinder head and cylinder head cover mating surfaces	Sealant (Quick Gasket®) Yamaha bond No.1215
AC magneto lead grommet (AC magneto cover)	Sealant (Quick Gasket®) Yamaha bond No.1215



**COOLANT FLOW DIAGRAMS**

- ① Radiator
- ② Radiator fan
- ③ Radiator outlet hose
- ④ Water pump inlet hose
- ⑤ Water pump
- ⑥ Water jacket outlet pipe
- ⑦ Thermostat inlet hose
- ⑧ Thermostat
- ⑨ Radiator inlet hose
- ⑩ Thermo switch 2
- ⑪ Thermo switch 1

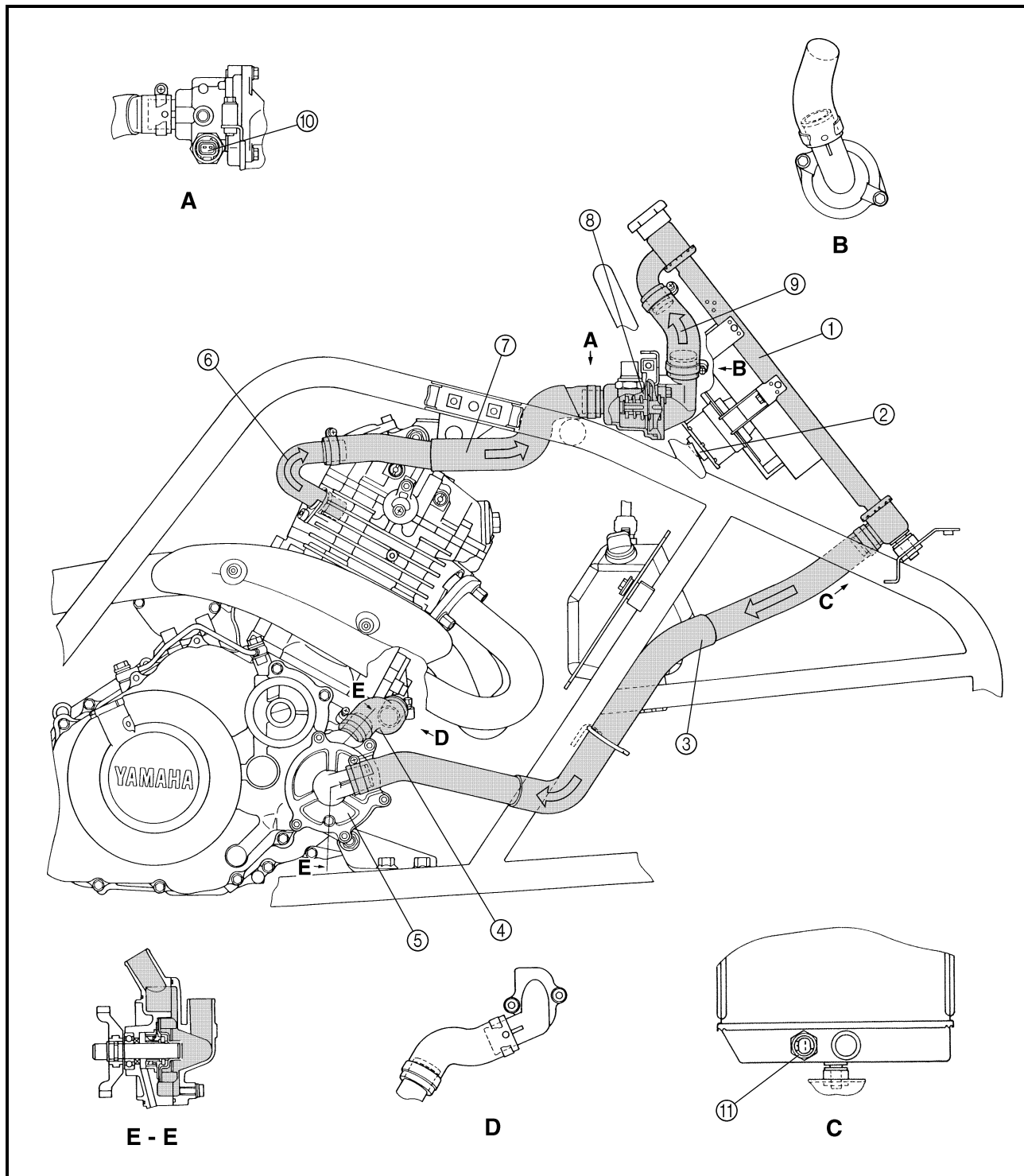

**OIL FLOW DIAGRAMS**

- ① Oil tank
- ② Oil pipe 2
- ③ Oil pipe 1

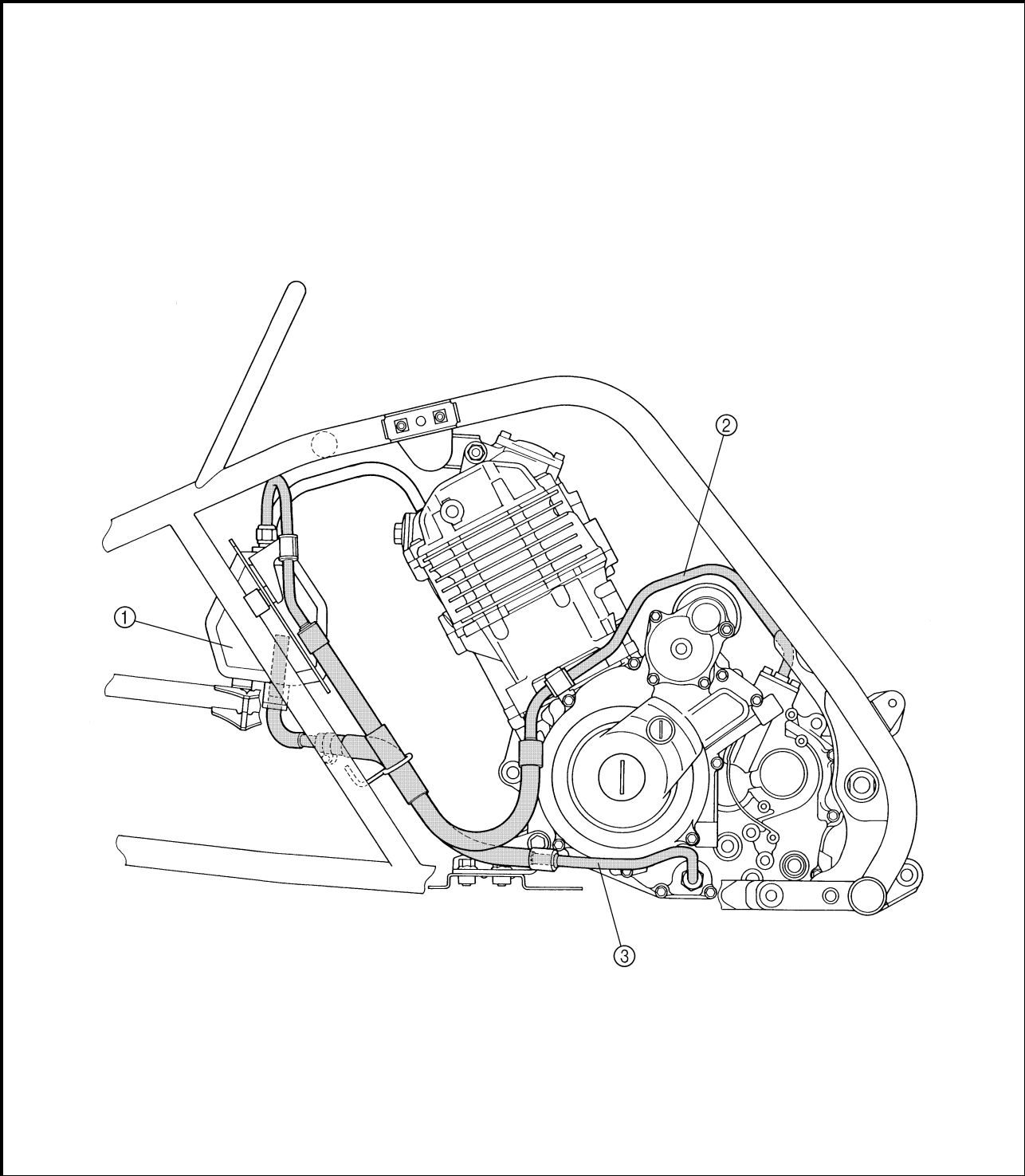

- ① Oil delivery pipe 2
- ② Oil delivery pipe 1
- ③ Oil filter
- ④ Crankshaft
- ⑤ Oil pump

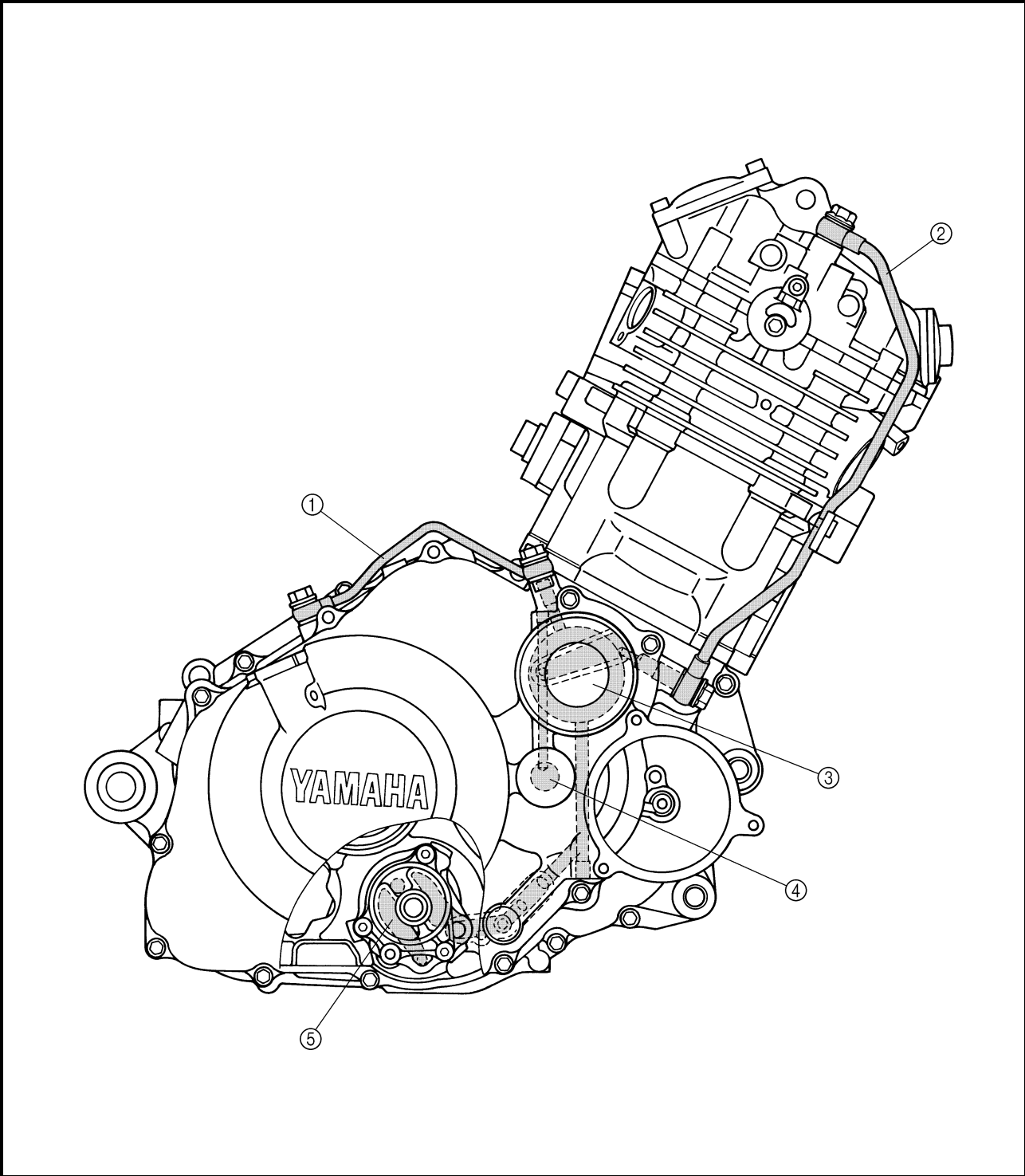



- ① Oil pipe 2
- ② Drive axle
- ③ Main axle
- ④ Engine oil drain bolt (engine)
- ⑤ Oil pipe 1
- ⑥ Oil strainer
- ⑦ Shift drum

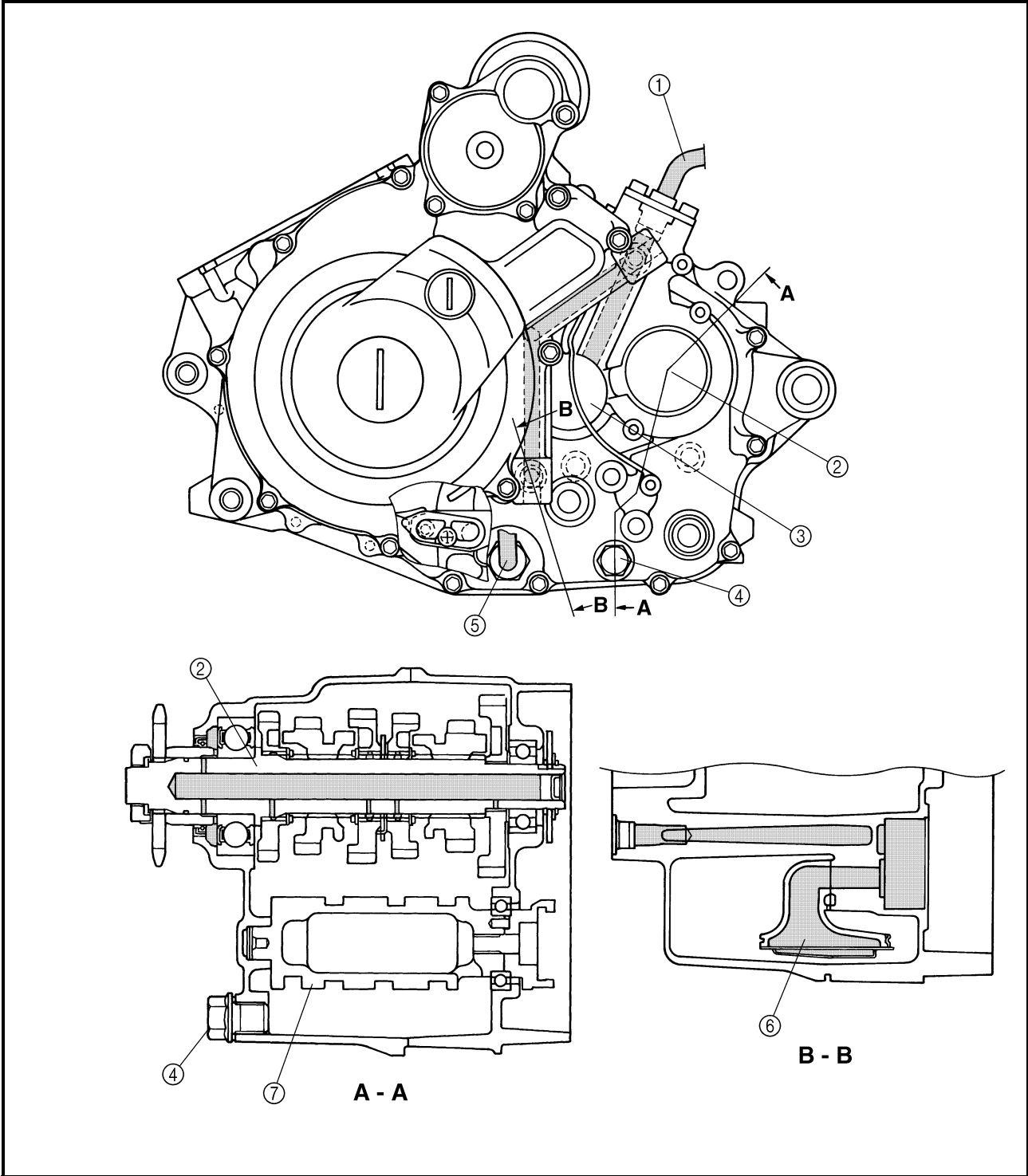

- ① Oil delivery pipe 2
- ② Oil filter cartridge
- ③ Oil pump rotor 1
- ④ Oil pump rotor 2
- ⑤ Oil pipe 1
- ⑥ Main axle

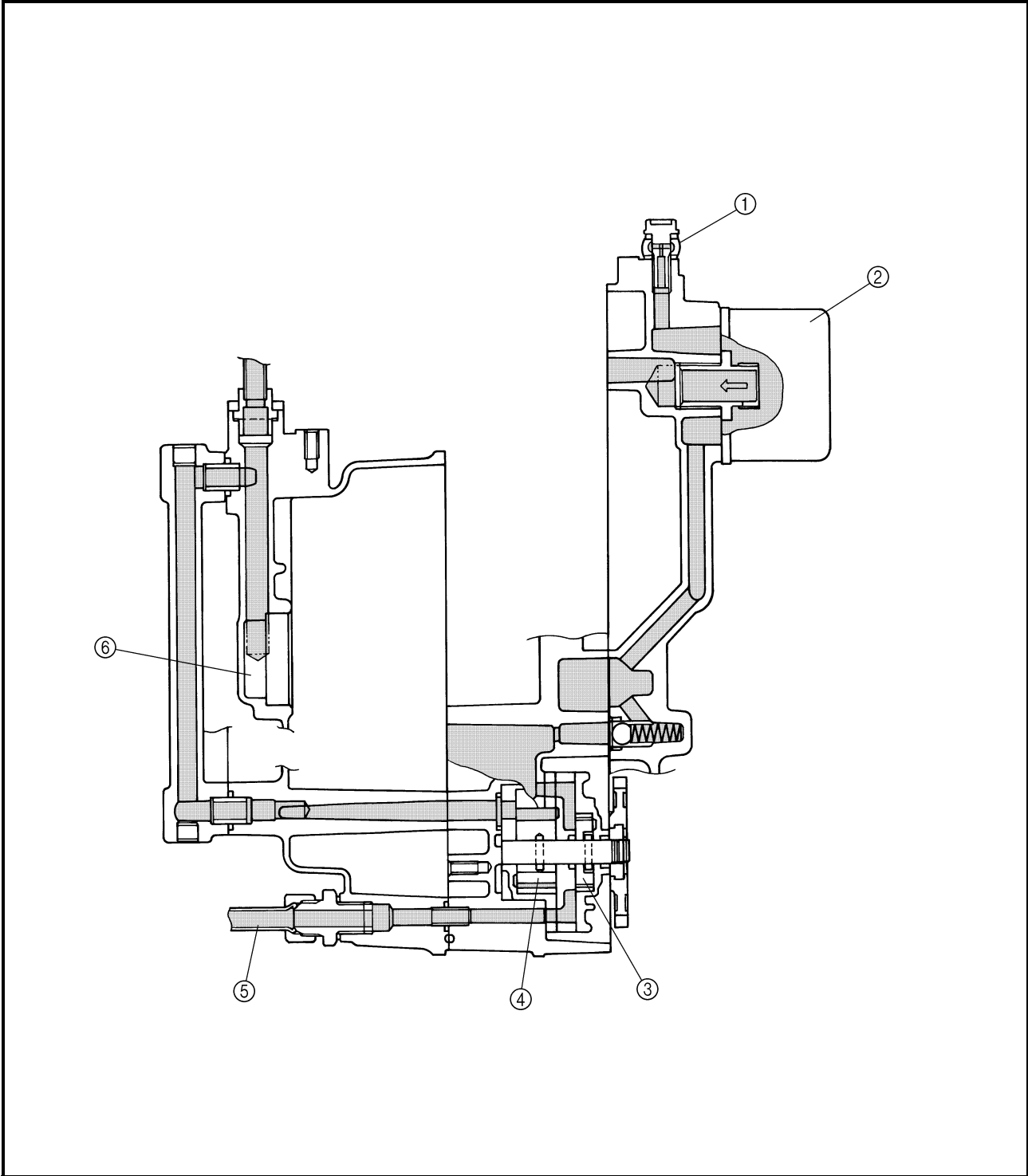





## CABLE ROUTING

- ① Parking brake cable
- ② Starter cable
- ③ Clutch cable
- ④ Throttle cable
- ⑤ Front brake hose
- ⑥ Front brake switch
- ⑦ Park switch

- A** Fasten the handlebar switch lead, park switch lead and clutch switch lead to the handlebar with the plastic band.
- B** Fasten the front brake switch lead to the handlebar with the plastic band.

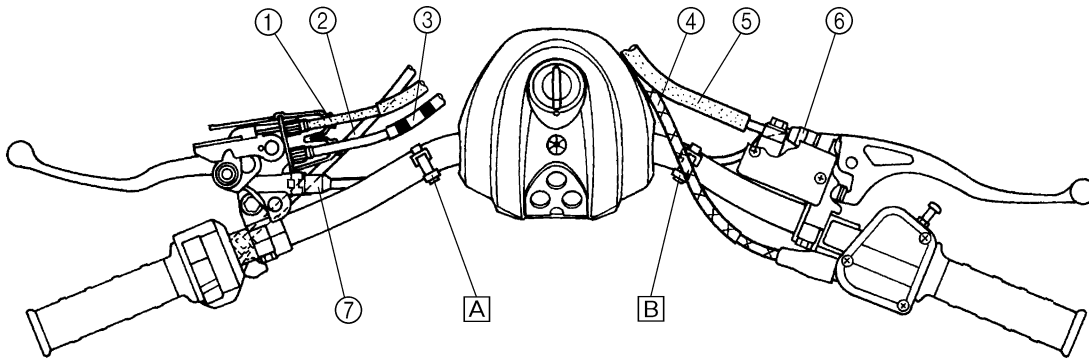



- ① Front brake hose
- ② Throttle cable
- ③ Main switch lead
- ④ Indicator light lead
- ⑤ Clutch cable
- ⑥ Parking brake cable
- ⑦ Starter cable
- ⑧ Coolant reservoir hose
- ⑨ Wire harness
- ⑩ Ignition coil lead
- ⑪ Headlight lead coupler (left)

- ⑫ Brake pipe
- ⑬ Headlight lead coupler (right)
- ⑭ Radiator fan breather hose
- ⑮ Headlight lead (right)

- A Pass the throttle cable through the cable guide.
- B Pass the clutch cable, parking brake cable and starter cable through the cable guide.
- C Fasten the left and right headlight lead, radiator fan lead and thermo switch 1 lead to the frame with the plastic band.

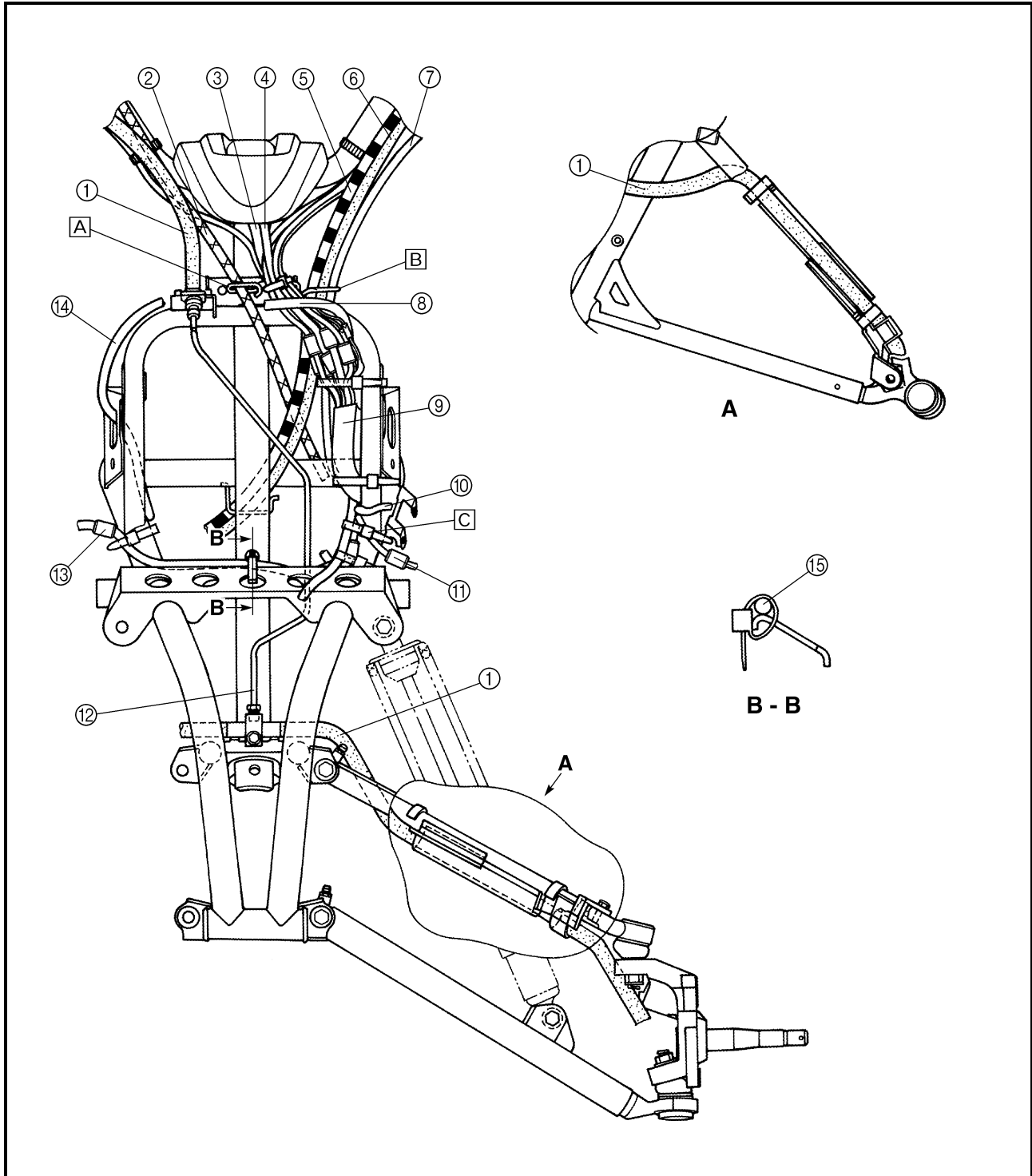



- ① Throttle cable
- ② Fuel tank breather hose
- ③ Fuel hose
- ④ Carburetor air vent hose
- ⑤ Negative battery lead
- ⑥ AC magneto lead
- ⑦ Thermo switch 1
- ⑧ Coolant reservoir hose
- ⑨ Starter cable

- A Put the wire harness and coolant reservoir hose with the plastic holder.
- B Fasten the wire harness, AC magneto lead, speed sensor lead, negative battery lead and rear brake switch lead with the plastic band.
- C 70 mm (2.76 in)
- D 25 ~ 35 mm (0.98 ~ 1.38 in)
- E 60 mm (2.36 in)
- F 0 ~ 5 mm (0 ~ 0.20 in)
- G 80 ~ 90 mm (3.15 ~ 3.54 in)

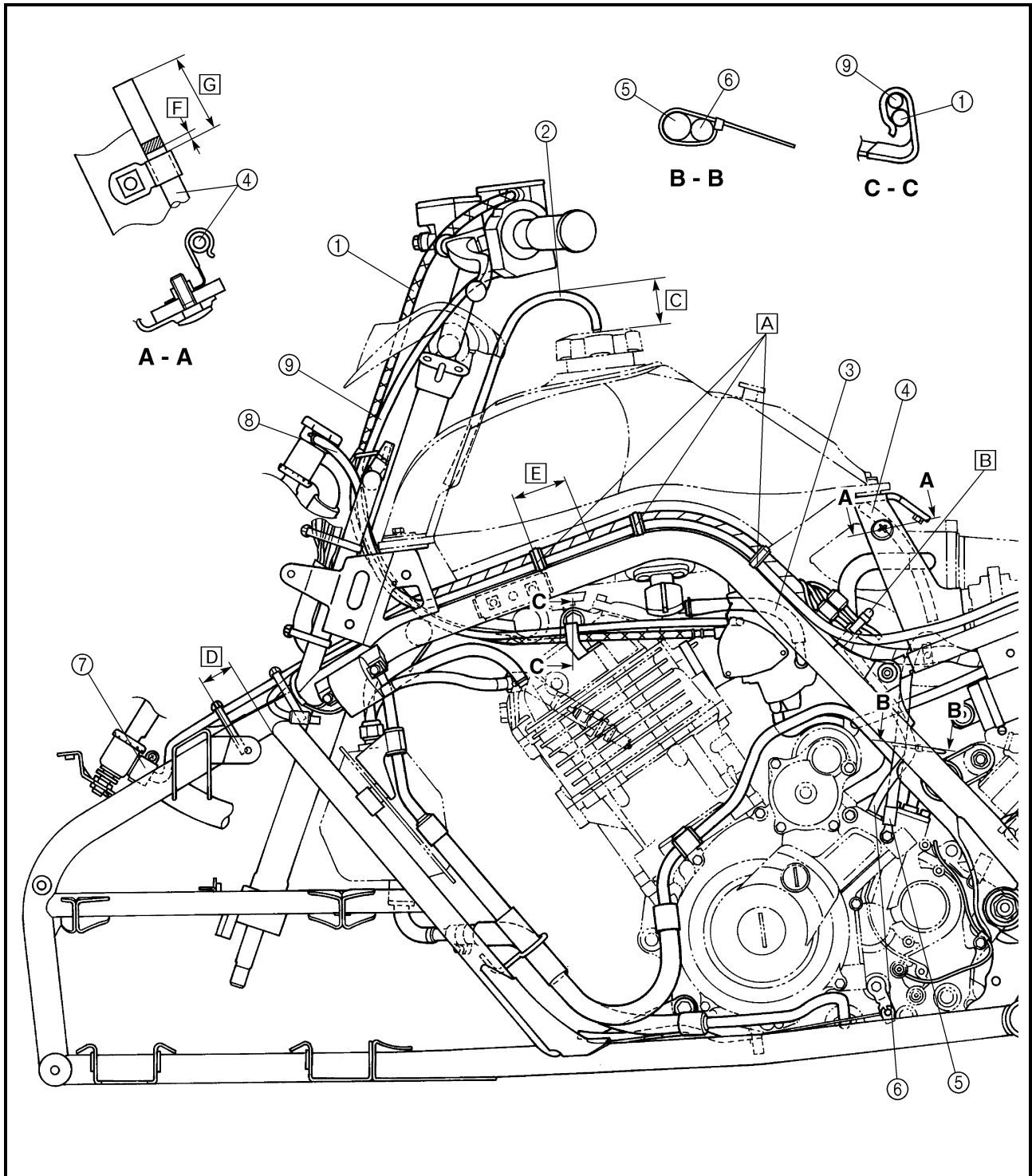

- ① Coolant reservoir hose
- ② Carburetor air vent hose
- ③ Reservoir tank breather hose
- ④ Rectifier/regulator
- ⑤ CDI unit
- ⑥ Negative battery lead
- ⑦ AC magneto lead
- ⑧ Wire harness
- ⑨ Starter motor lead
- ⑩ Tail/brake light lead
- ⑪ Rectifier/regulator lead

**A** Pass the negative battery lead between the wire harness and frame.

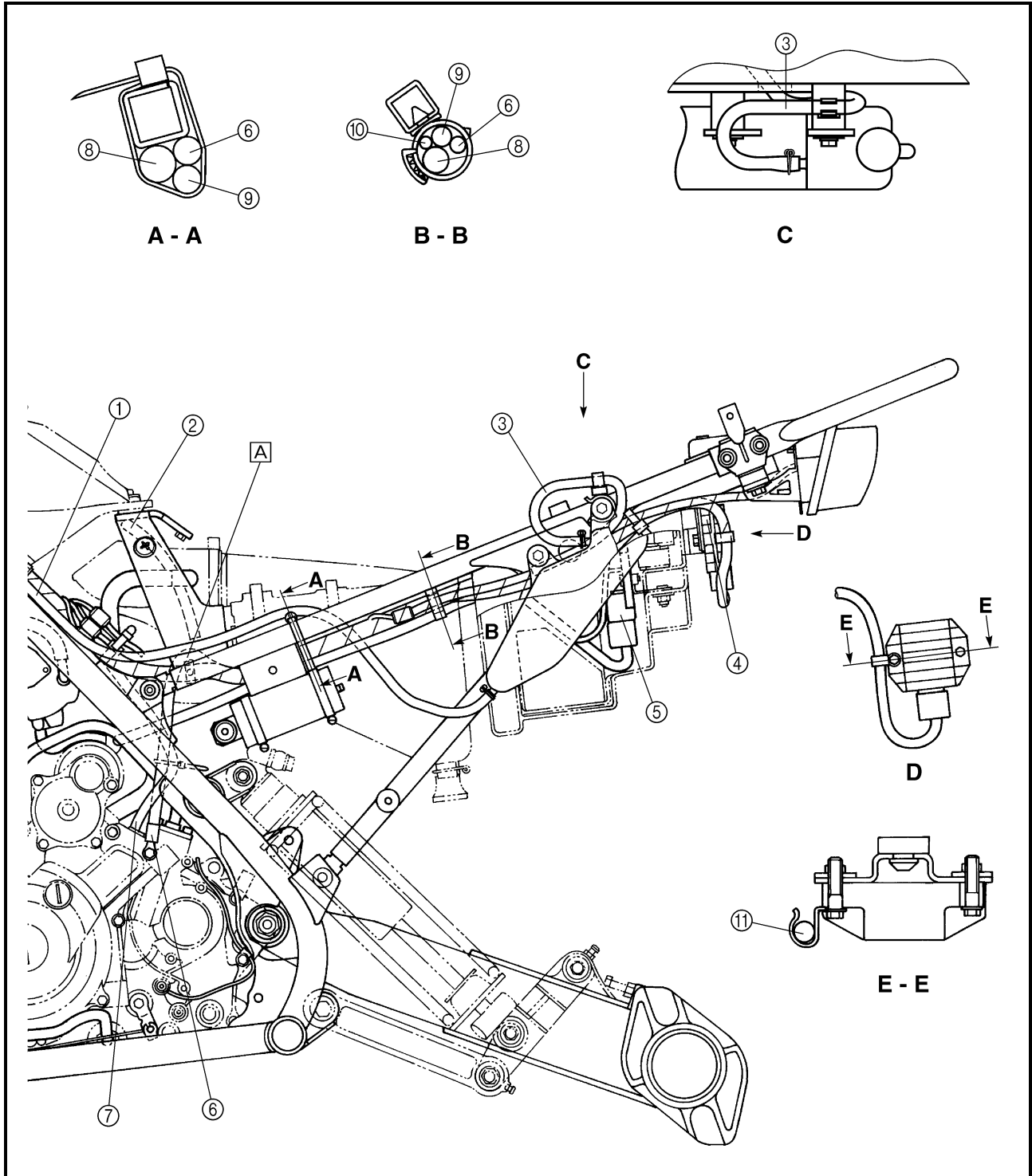



- ① Radiator fan breather hose
- ② Reverse control cable
- ③ Parking brake cable
- ④ Clutch cable

- Ⓐ Fasten the reverse control cable to the frame with the plastic band.
- Ⓑ 15 ~ 25 mm (0.59 ~ 0.98 in)

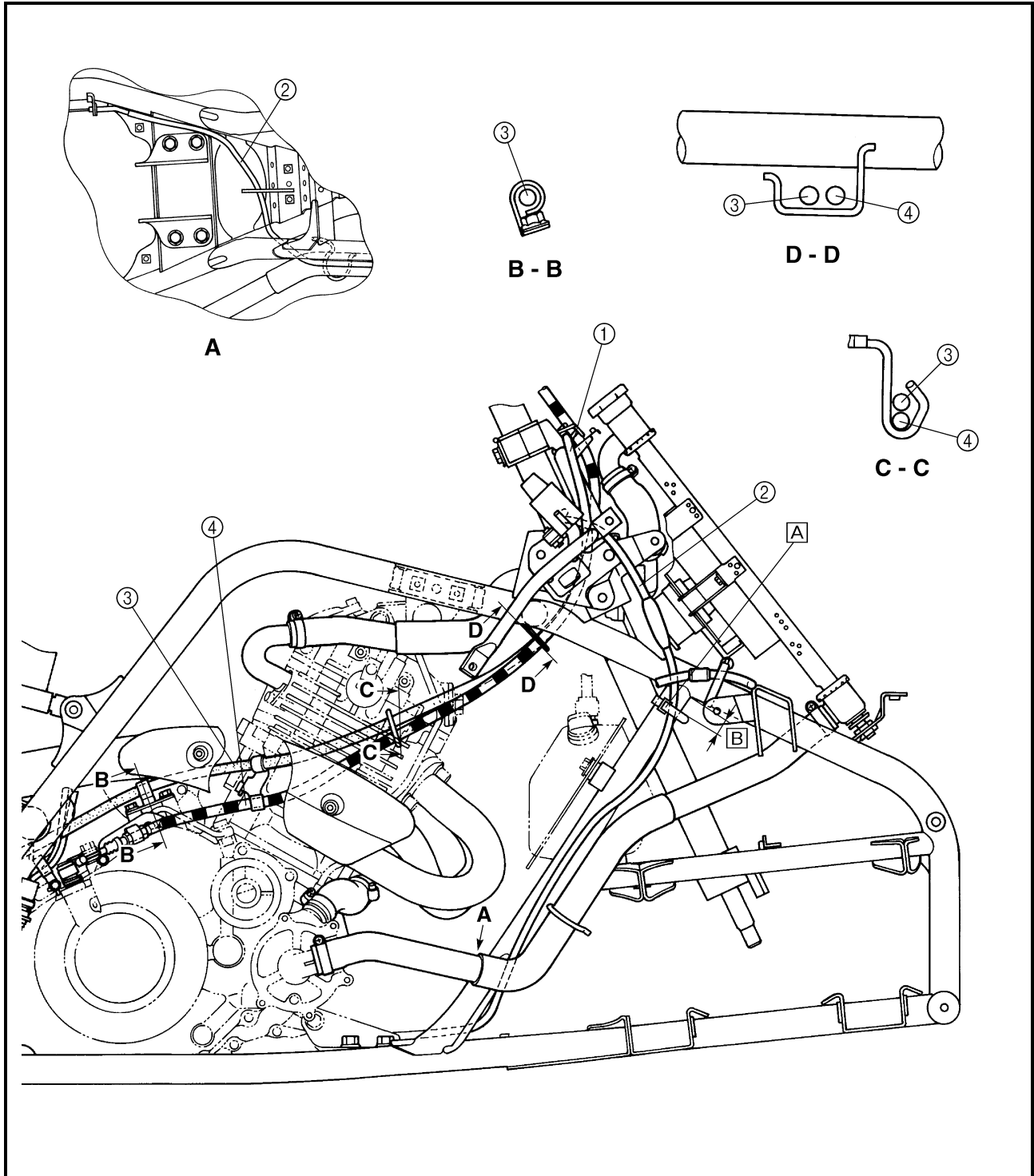



- ① Rear brake hose
- ② Parking brake cable
- ③ Negative battery lead
- ④ AC magneto lead
- ⑤ Crankcase breather hose
- ⑥ Carburetor drain hose
- ⑦ Rear brake switch
- ⑧ Speed sensor
- ⑨ Speed sensor lead
- ⑩ Rear brake switch lead

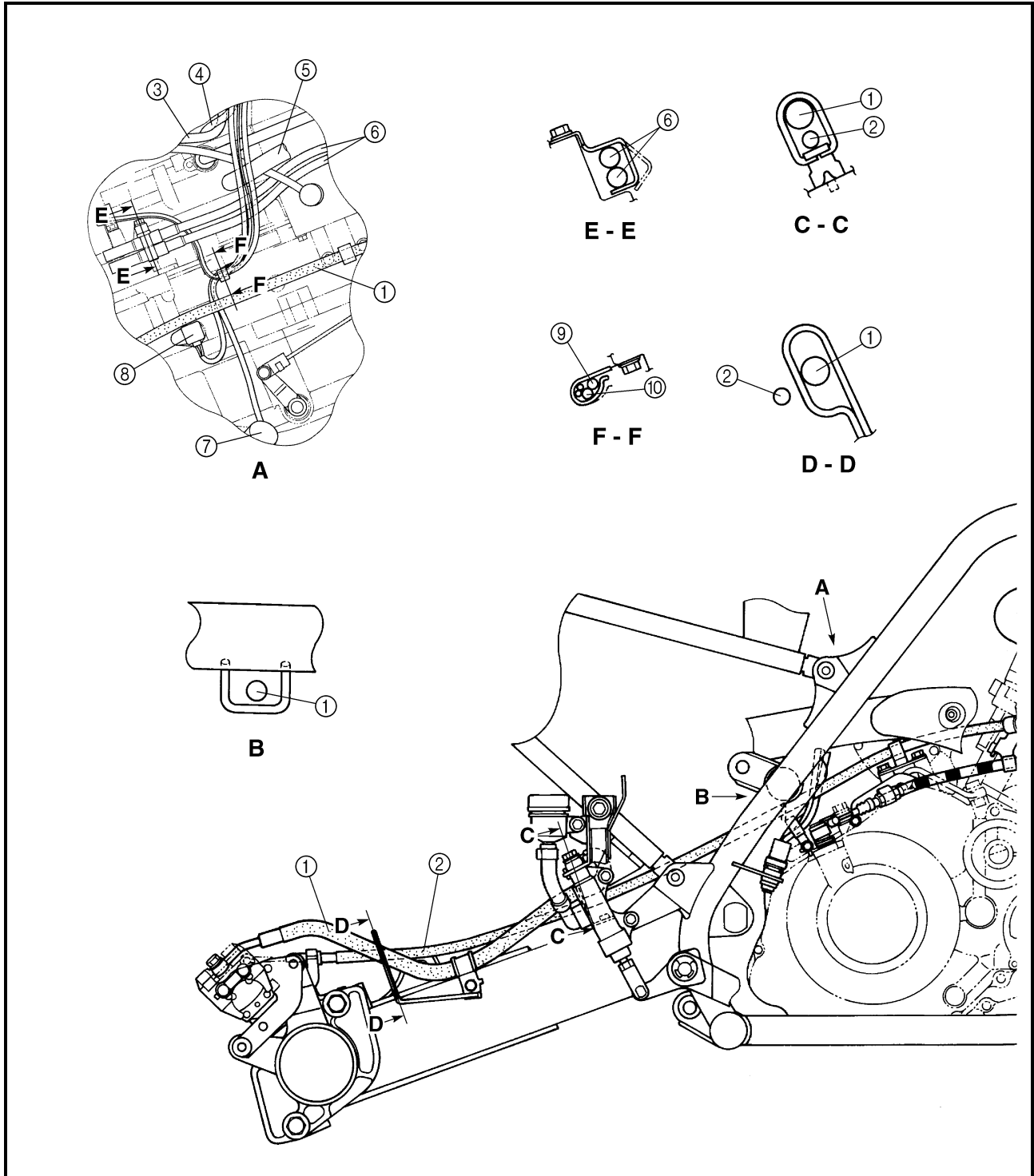



- ① Thermo switch 1 lead
- ② Headlight lead (right)
- ③ Radiator fan breather hose
- ④ Thermo switch 2 lead
- ⑤ Carburetor breather hose
- ⑥ Headlight lead (left)
- ⑦ Wire harness
- ⑧ Coolant reservoir hose

- Ⓐ Fasten the fan motor lead, headlight lead (right) and thermo switch 1 lead to the frame with the plastic band.

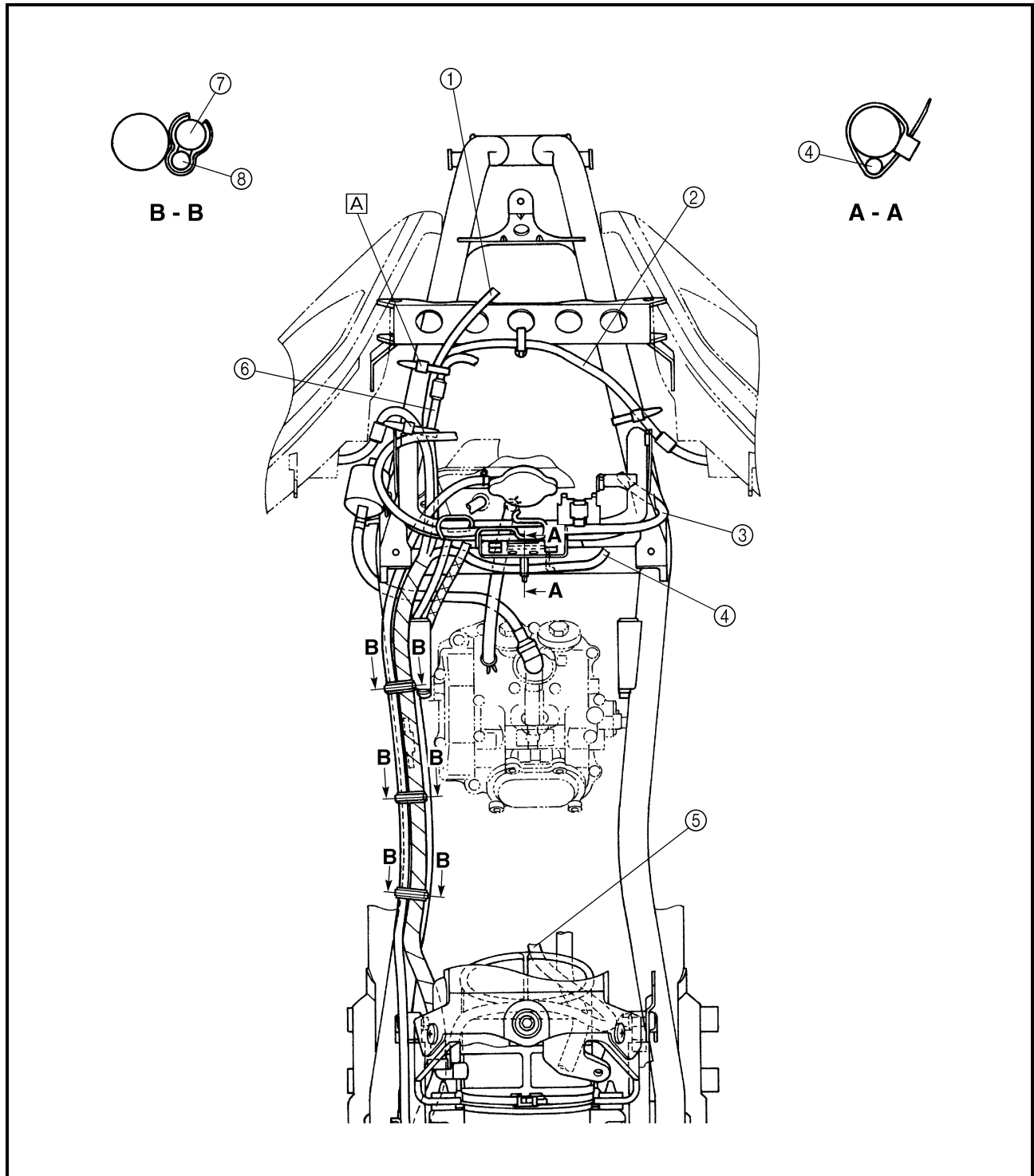



- ① Positive battery lead
- ② Tail/brake light lead
- ③ Coolant reservoir breather hose
- ④ Negative battery lead
- ⑤ Coolant reservoir hose
- ⑥ Starter motor lead
- ⑦ Wire harness
- ⑧ Rectifier/regulator lead

- A Fasten the wire harness with the plastic clamp.
- B Fasten the starter motor lead and starter relay lead with the plastic clamp.

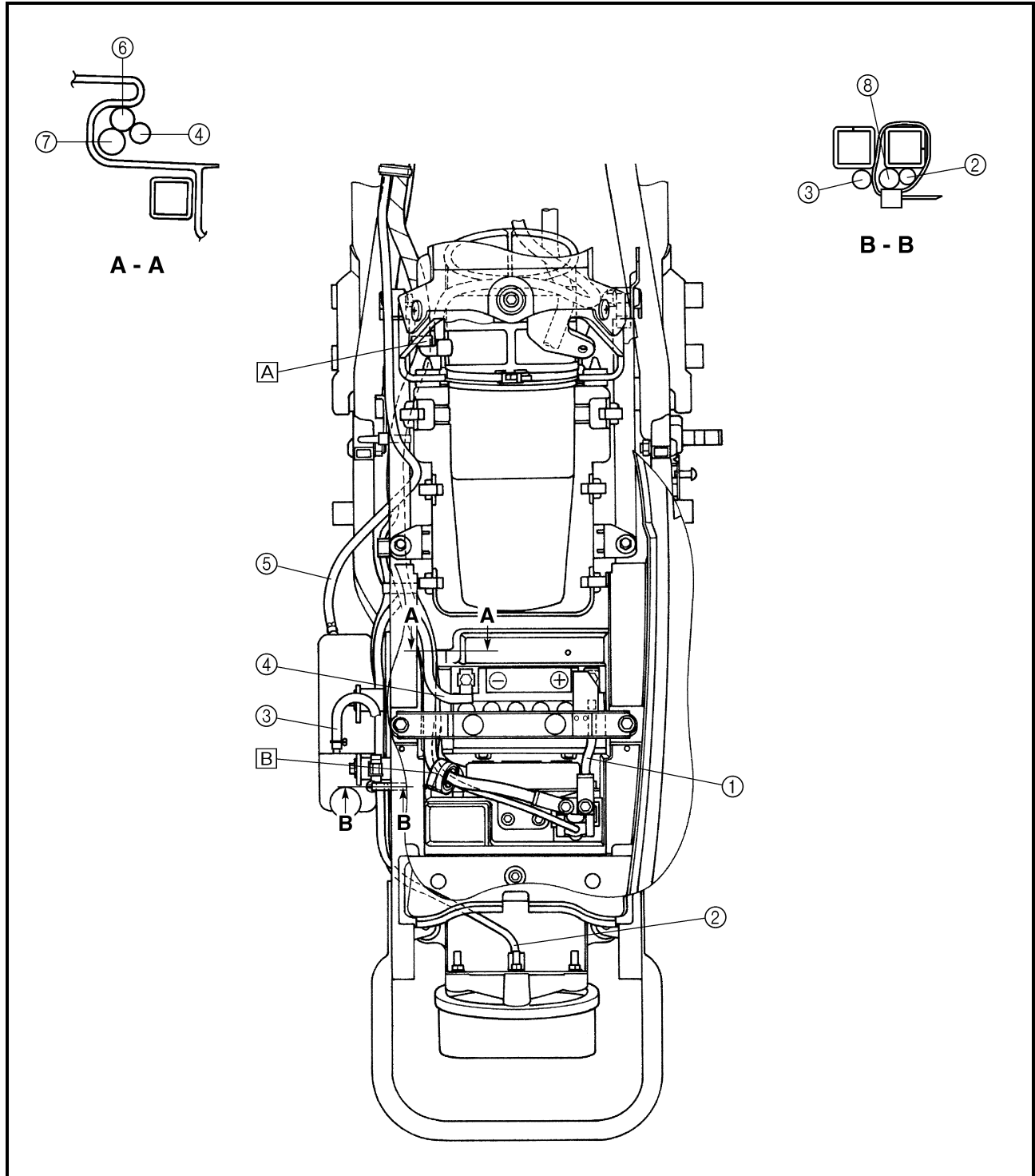



EB300000

## PERIODIC CHECKS AND ADJUSTMENTS

### INTRODUCTION

This chapter includes all information necessary to perform recommended inspections and adjustments. These preventive maintenance procedures, if followed, will ensure more reliable vehicle operation and a longer service life. The need for costly overhaul work will be greatly reduced. This information applies to vehicles already in service as well as to new vehicles that are being prepared for sale. All service technicians should be familiar with this entire chapter.

EB301000

### PERIODIC MAINTENANCE/LUBRICATION INTERVALS

ITEM	ROUTINE	INITIAL			EVERY	
		1 month	3 months	6 months	6 months	1 year
<b>Valves*</b> (See page 3-8.)	<ul style="list-style-type: none"> <li>• Check valve clearance.</li> <li>• Adjust if necessary.</li> </ul>	○		○	○	○
<b>Cooling system</b> (See page 3-27.)	<ul style="list-style-type: none"> <li>• Check coolant leakage.</li> <li>• Repair if necessary.</li> <li>• Replace coolant every 24 months.</li> </ul>	○	○	○	○	○
<b>Spark plug</b> (See page 3-16.)	<ul style="list-style-type: none"> <li>• Check condition.</li> <li>• Adjust gap and clean.</li> <li>• Replace if necessary.</li> </ul>	○	○	○	○	○
<b>Air filter</b> (See page 3-24.)	<ul style="list-style-type: none"> <li>• Clean.</li> <li>• Replace if necessary.</li> </ul>	Every 20~40 hours (More often in wet or dusty areas.)				
<b>Carburetor*</b> (See page 3-11.)	<ul style="list-style-type: none"> <li>• Check and adjust idle speed/starter operation.</li> <li>• Adjust if necessary.</li> </ul>		○	○	○	○
<b>Crankcase breather system*</b>	<ul style="list-style-type: none"> <li>• Check breather hose for cracks or damage.</li> <li>• Replace if necessary.</li> </ul>			○	○	○
<b>Exhaust system*</b>	<ul style="list-style-type: none"> <li>• Check for leakage.</li> <li>• Retighten if necessary.</li> <li>• Replace gasket if necessary.</li> </ul>			○	○	○
<b>Spark arrester</b> (See page 3-31.)	<ul style="list-style-type: none"> <li>• Clean.</li> </ul>			○	○	○
<b>Fuel line*</b>	<ul style="list-style-type: none"> <li>• Check fuel hose for cracks or damage.</li> <li>• Replace if necessary.</li> </ul>			○	○	○
<b>Engine oil</b> (See page 3-19.)	<ul style="list-style-type: none"> <li>• Replace (Warm engine before draining).</li> </ul>	○		○	○	○
<b>Engine oil filter</b>	<ul style="list-style-type: none"> <li>• Replace if necessary.</li> </ul>	○		○		○
<b>Drive chain</b> (See page 3-40.)	<ul style="list-style-type: none"> <li>• Check and adjust slack/alignment/clean/lube.</li> </ul>	○	○	○	○	○
<b>Brake*</b> (See page 3-33.)	<ul style="list-style-type: none"> <li>• Check operation/fluid leakage/See NOTE page 3-2.</li> <li>• Correct if necessary.</li> </ul>	○	○	○	○	○
<b>Clutch*</b> (See page 3-23.)	<ul style="list-style-type: none"> <li>• Check operation.</li> <li>• Adjust if necessary.</li> </ul>	○		○	○	○
<b>Wheels*</b> (See page 4-3.)	<ul style="list-style-type: none"> <li>• Check balance/damage/runout.</li> <li>• Replace if necessary.</li> </ul>	○		○	○	○
<b>Wheel bearings*</b>	<ul style="list-style-type: none"> <li>• Check bearing assembly for looseness/damage.</li> <li>• Replace if damaged.</li> </ul>	○		○	○	○
<b>Steering system*</b> (See page 3-42.)	<ul style="list-style-type: none"> <li>• Check operation.</li> <li>• Replace if damaged.</li> <li>• Check toe-in.</li> <li>• Adjust if necessary.</li> </ul>	○	○	○	○	○
<b>Upper and lower arm pivot and steering shaft*</b>	<ul style="list-style-type: none"> <li>• Lubricate every 6 months.**</li> </ul>			○	○	○
<b>Rear arm pivot*</b>	<ul style="list-style-type: none"> <li>• Lubricate every 6 months.**</li> </ul>			○	○	○
<b>Fittings and fasteners*</b>	<ul style="list-style-type: none"> <li>• Check all chassis fittings and fasteners.</li> <li>• Correct if necessary.</li> </ul>	○	○	○	○	○

\* It is recommended that these items be serviced by a Yamaha dealer.

\*\* Lithium soap base grease



**NOTE:**

- Recommended brake fluid: DOT 4
- Brake fluid replacement:
  1. When disassembling the master cylinder or caliper cylinder, replace the brake fluid. Normally check the brake fluid level and add fluid as required.
  2. On the inner parts of the master cylinder and caliper cylinder, replace the oil seals every two years.
  3. Replace the brake hoses every four years, or if cracked or damaged.

**⚠ WARNING**

**Indicates a potential hazard that could result in serious injury or death.**

## SEAT, FENDERS AND FUEL TANK

### SEAT, FRONT PANEL, FOOTREST GUARDS AND ENGINE SKID PLATE

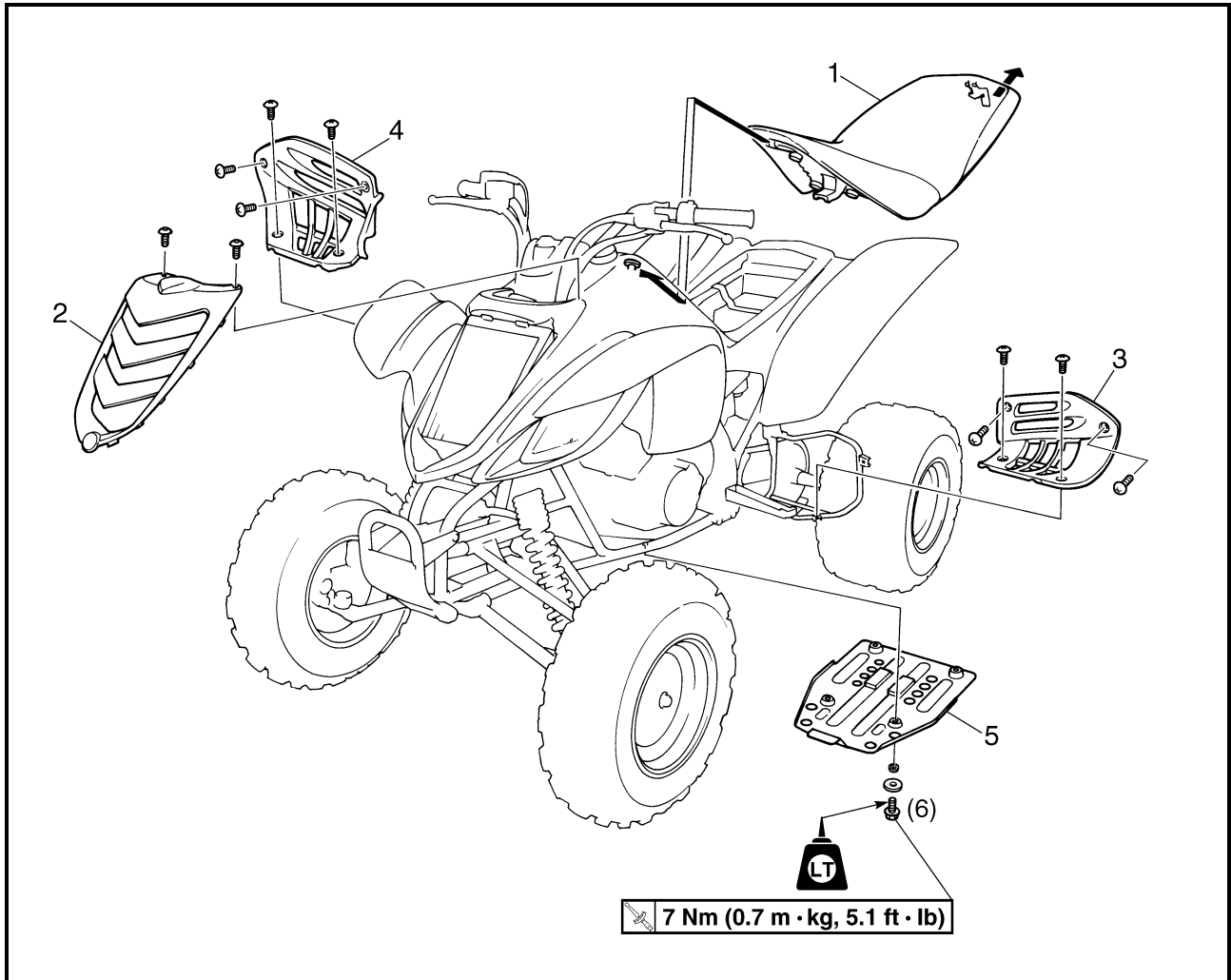

Order	Job name/Part name	Q'ty	Remarks
	<b>Removing the seat, front panel, footrest guard and engine skid plate</b>		Remove the parts in the order below.
1	Seat	1	<b>NOTE:</b> _____ Pull back the seat lock lever, than pull up on the rear of the seat.
2	Front panel	1	
3	Left footrest guard	1	
4	Right footrest guard	1	
5	Engine skid plate	1	
			For installation, reverse the removal procedure.

## HEADLIGHTS AND FRONT FENDER

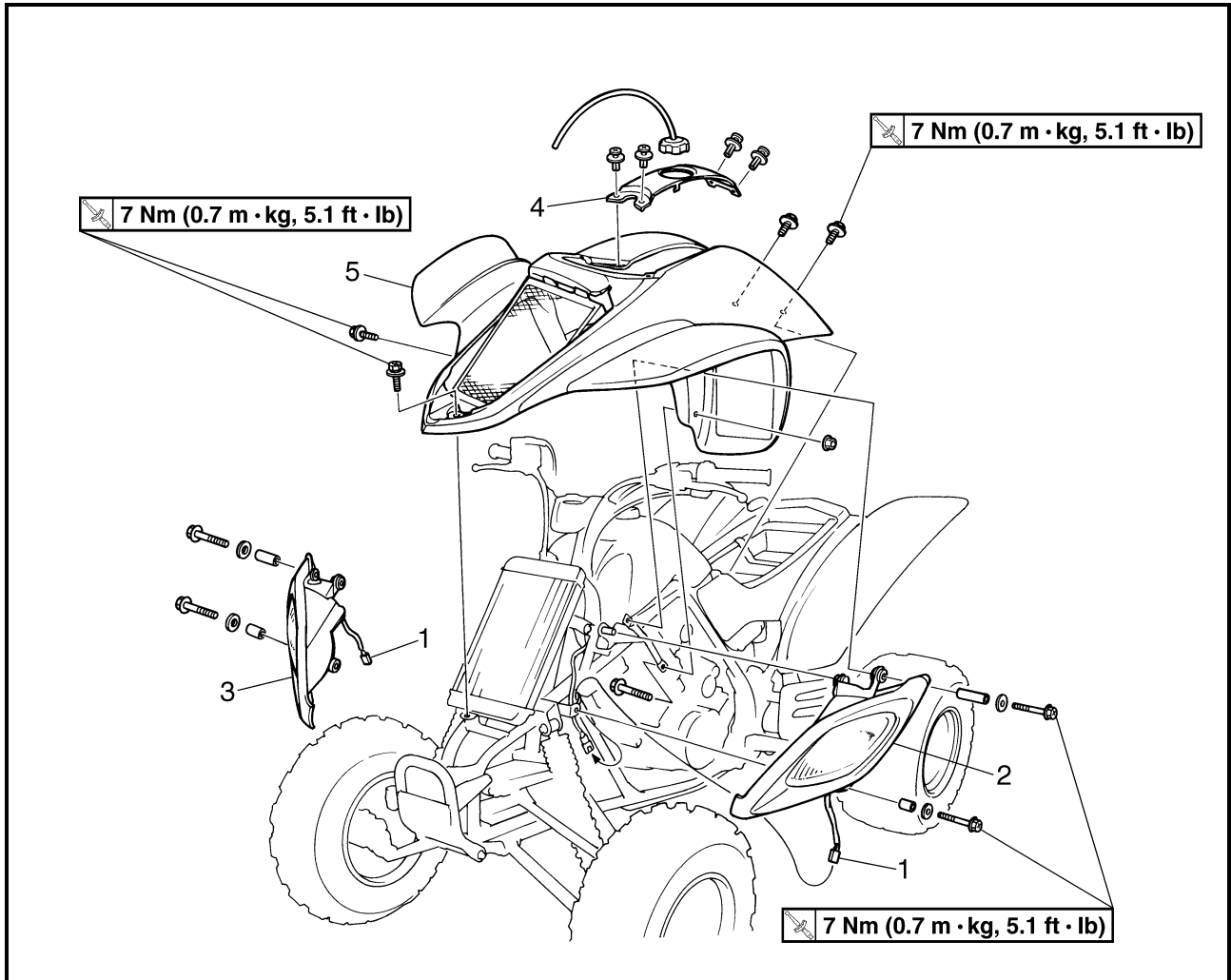

Order	Job name/Part name	Q'ty	Remarks
	<b>Removing the headlight and front fender</b>		Remove the parts in the order below.
	Seat and front panel		Refer to "SEAT, FRONT PANEL, FOOT-REST GUARDS AND ENGINE SKID PLATE".
1	Headlight coupler	2	Disconnect.
2	Left headlight	1	
3	Right headlight	1	
4	Fuel tank top panel	1	
5	Front fender	1	
			For installation, reverse the removal procedure.

REAR FENDER

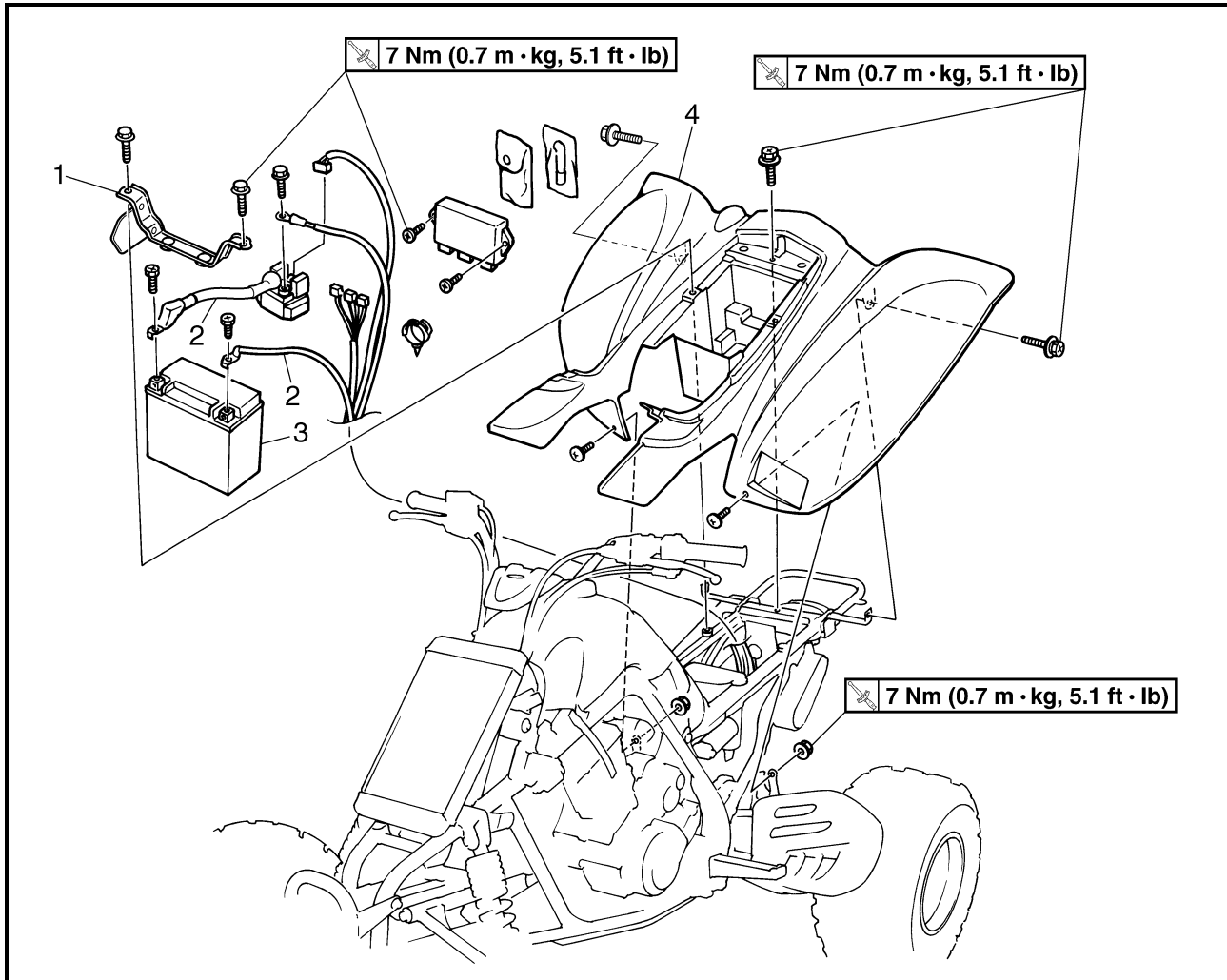

Order	Job name/Part name	Q'ty	Remarks
	<b>Removing the rear fender</b>		Remove the parts in the order below.
	Seat		Refer to "SEAT, FRONT PANEL, FOOT-REST GUARDS AND ENGINE SKID PLATE".
	Front fender		Refer to "HEADLIGHTS AND FRONT FENDER".
1	Battery holding bracket	1	
2	Battery lead	2	Disconnect.
			<b>CAUTION:</b> <u>First disconnect the negative lead, then disconnect the positive lead.</u>
3	Battery	1	
4	Rear fender	1	
			For installation, reverse the removal procedure.



## FUEL TANK

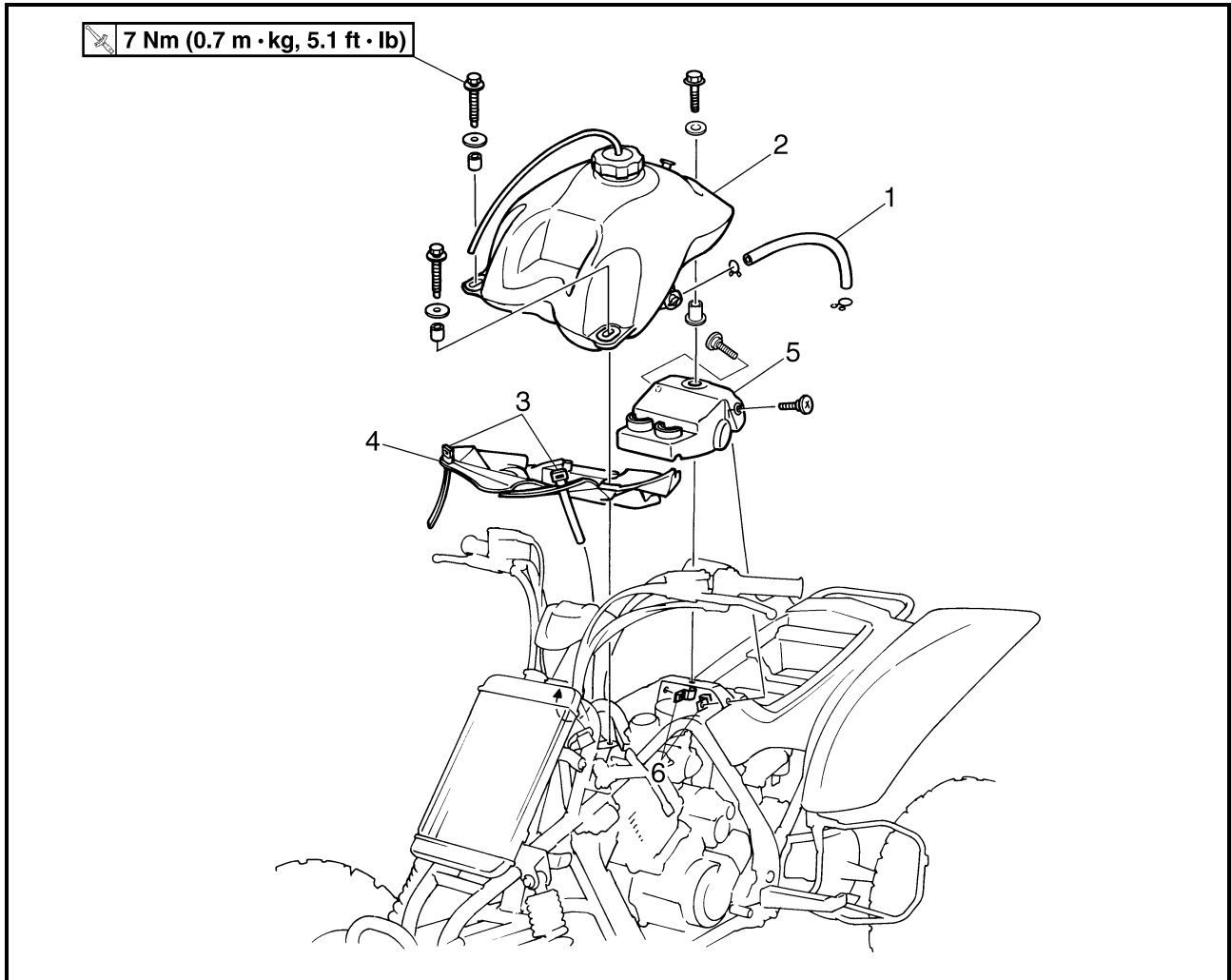

Order	Job name/Part name	Q'ty	Remarks
	<b>Removing the fuel tank</b>		
	Seat and front panel		Remove the parts in the order below. Refer to "SEAT, FRONT PANEL, FOOT-REST GUARDS AND ENGINE SKID PLATE".
	Front fender		Refer to "HEADLIGHTS AND FRONT FENDER".
1	Fuel hose	1	<b>NOTE:</b> _____ Before disconnecting the fuel hose, turn the fuel cock to "OFF".
2	Fuel tank	1	<b>NOTE:</b> _____ When installing the fuel tank, pass the fuel tank breather hose through the hole in the handlebar protector.
3	Plastic band	2	_____

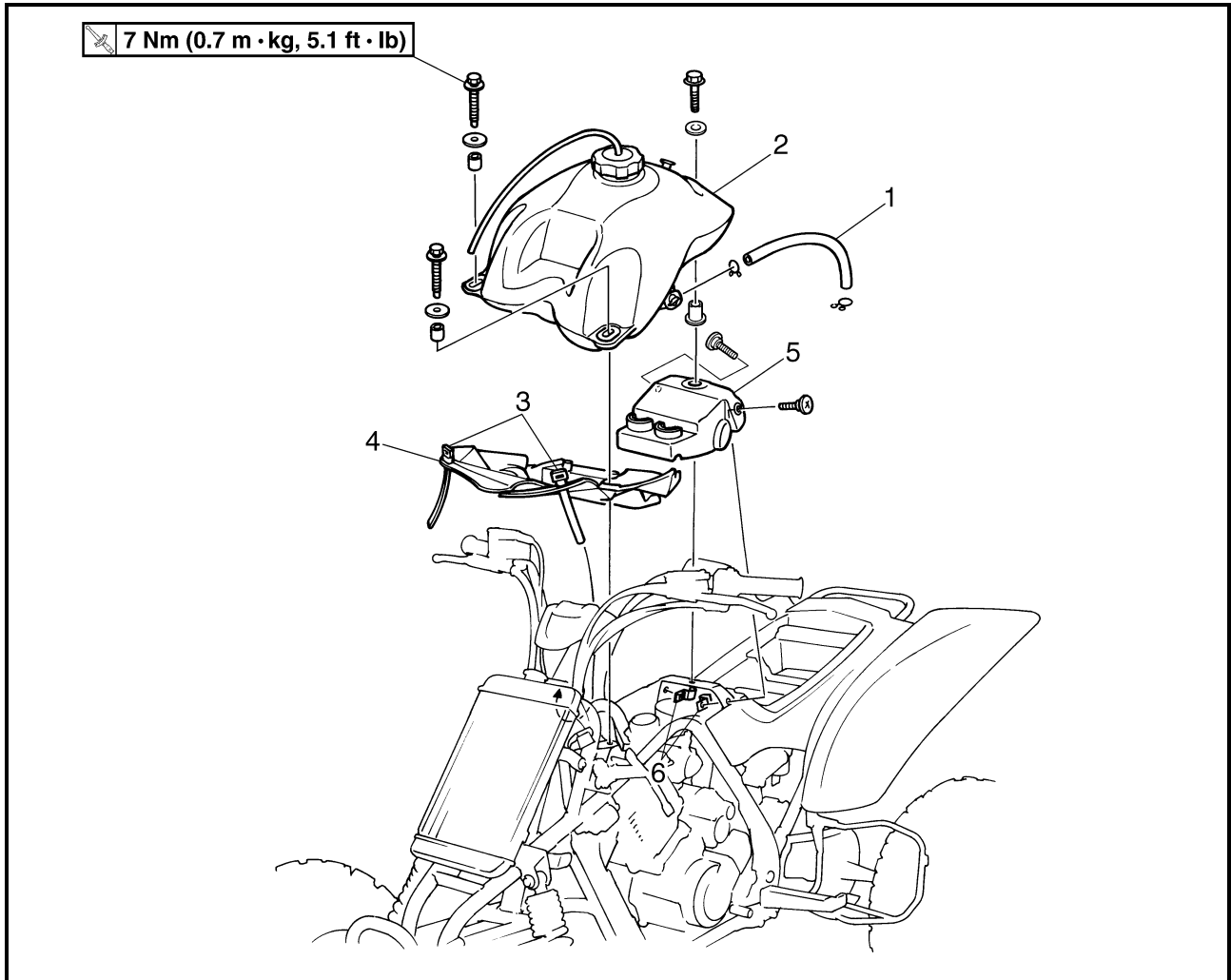

Order	Job name/Part name	Q'ty	Remarks
4	Rubber cover 1	1	For installation, reverse the removal procedure.
5	Rubber cover 2	1	
6	Hose holder	2	

## ENGINE

### ADJUSTING THE VALVE CLEARANCE

**NOTE:** \_\_\_\_\_

- The valve clearance must be adjusted when the engine is cool to the touch.
- Adjust the valve clearance when the piston is at the Top Dead Center (T.D.C.) on the compression stroke.

1.Remove:

- Seat
- Front fender
- Fuel tank

Refer to "SEAT, FENDERS AND FUEL TANK".

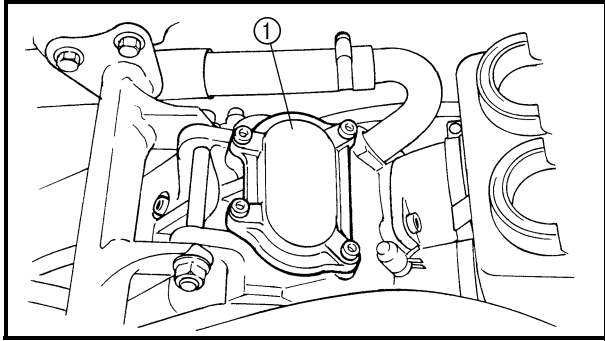

2.Remove:

- Tappet cover (intake) ①
- Tappet covers (exhaust) ②

3.Disconnect:

- Spark plug cap ③

4.Remove:

- Spark plug

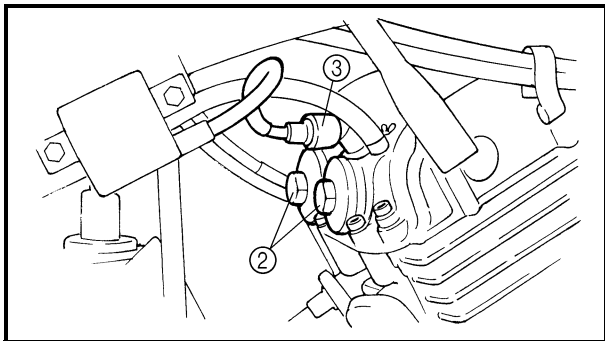

5.Remove:

- Crankshaft end accessing screw ①
- Timing mark accessing screw ②

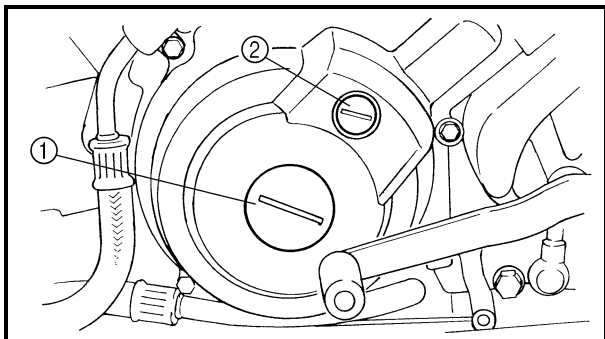



6. Check:
- Valve clearance  
Out of specification → Adjust.

	<b>Valve clearance (cold):</b> <b>Intake:</b> 0.10 ~ 0.15 mm (0.0039 ~ 0.0059 in) <b>Exhaust:</b> 0.15 ~ 0.20 mm (0.0059 ~ 0.0079 in)
---	---

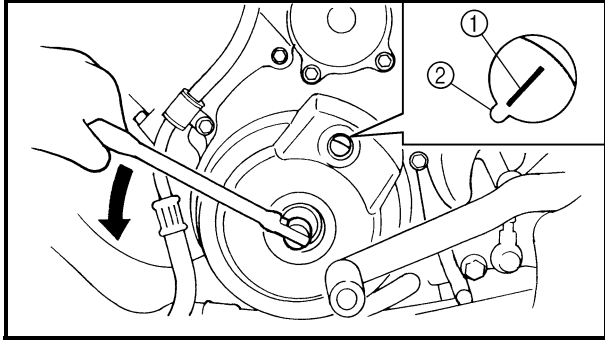

\*\*\*\*\*

**Checking steps:**

- Turn the crankshaft counterclockwise with a wrench.
- Align the “1” mark ① on the rotor with the stationary pointer ② on the crankcase cover. When the “1” mark is aligned with the stationary pointer, the piston is at the Top Dead Center (T.D.C.).

**NOTE:**

- When the piston is at the Top Dead Center (T.D.C.) on the compression stroke, there should be clearance between the valve stem tips and their respective rocker arm adjusting screws.
- If there is no clearance, rotate the crankshaft counterclockwise one turn.

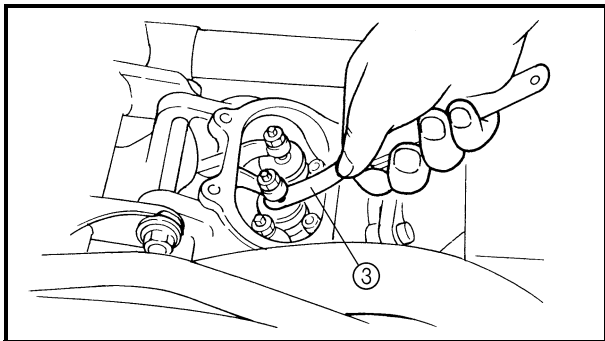

- Measure the valve clearance using a feeler gauge ③.

\*\*\*\*\*

# ADJUSTING THE VALVE CLEARANCE

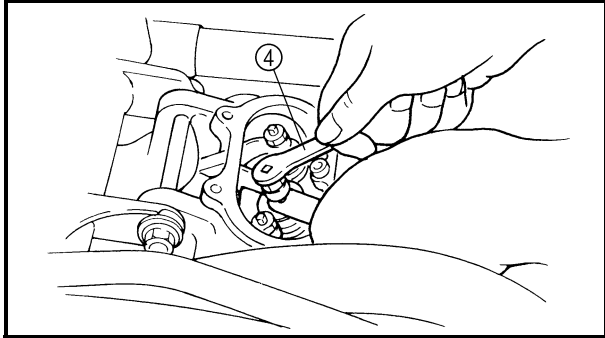
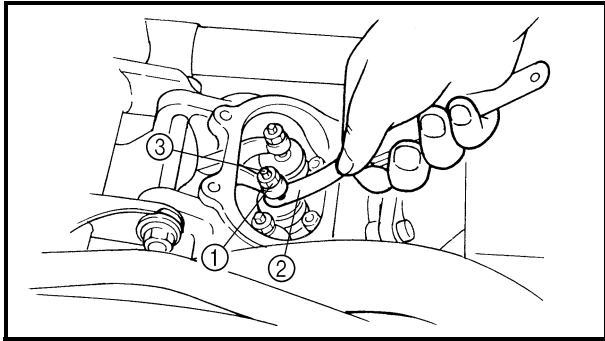

## 7.Adjust:

- Valve clearance

\*\*\*\*\*

### Adjustment steps:

- Loosen the locknut ①.
- Insert a feeler gauge ② between the adjuster end and the valve end.
- Turn the adjuster ③ clockwise or counter-clockwise with the tappet adjusting tool ④ until the proper clearance is obtained.



**Tappet adjusting tool:**  
P/N. YM-08035, 90890-01311

- Hold the adjuster to prevent it from moving and then tighten the locknut.



**Locknut:**  
14 Nm (1.4 m • kg, 10 ft • lb)

- Measure the valve clearance.
- If the clearance is incorrect, repeat the above steps until the proper clearance is obtained.

\*\*\*\*\*



## 8.Install:

- All removed parts

### NOTE:

Install all removed parts in the reverse order of their disassembly. Note the following points.

## 9.Install:

- Spark plug  18 Nm (1.8 m • kg, 13 ft • lb)
- Tappet cover (intake)  10 Nm (1.0 m • kg, 7.2 ft • lb)
- Tappet covers (exhaust)  12 Nm (1.2 m • kg, 8.7 ft • lb)



10. Install:

- Fuel tank
- Front fender
- Seat

Refer to "SEAT, FENDERS AND FUEL TANK".

### **ADJUSTING THE TIMING CHAIN**

Adjustment free.

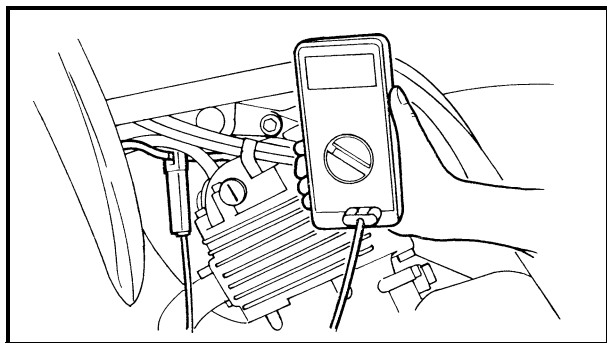

### **ADJUSTING THE IDLING SPEED**

1. Start the engine and let it warm up for several minutes.

2. Attach:

- Tachometer  
(to the spark plug lead)

3. Check:

- Engine idling speed  
Out of specification → Adjust.



**Engine idling speed:  
1,450 ~ 1,550 r/min**

# ADJUSTING THE IDLING SPEED/ ADJUSTING THE THROTTLE LEVER FREE PLAY

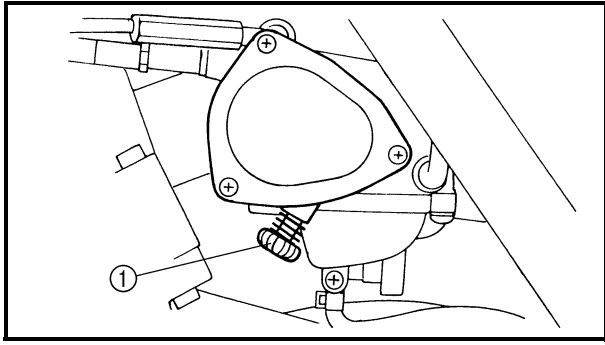

- 4.Adjust:
- Engine idling speed

\*\*\*\*\*

**Adjustment steps:**

- Turn the throttle stop screw ① in or out until the specified idling speed is obtained.

Turning in	Idling speed becomes higher.
Turning out	Idling speed becomes lower.

\*\*\*\*\*

5.Detach:

- Tachometer

6.Adjust:

- Throttle lever free play  
Refer to “ADJUSTING THE THROTTLE LEVER FREE PLAY”.

## ADJUSTING THE THROTTLE LEVER FREE PLAY

**NOTE:** \_\_\_\_\_

Engine idling speed should be adjusted properly before adjusting the throttle lever free play.

\_\_\_\_\_

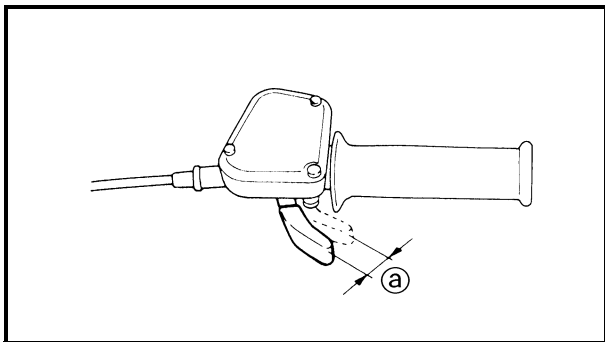

1.Check:

- Throttle lever free play ①  
Out of specification → Adjust.

	<b>Throttle lever free play: 3 ~ 5 mm (0.12 ~ 0.20 in)</b>
--	--

# ADJUSTING THE THROTTLE LEVER FREE PLAY

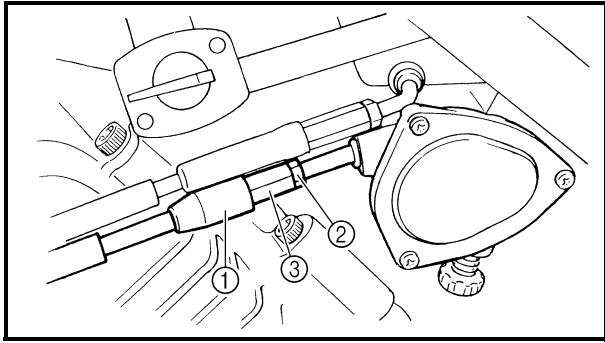

- 2.Adjust:
- Throttle lever free play

\*\*\*\*\*

**Adjustment steps:**

**First step:**

- Pull back the adjuster cover ①.
- Loosen the locknut ② on the carburetor side.
- Turn the adjuster ③ in or out until the correct free play is obtained.

Turning in	Free play is increased.
Turning out	Free play is decreased.

- Tighten the locknut ②.
- Push in the adjuster cover ①.

**NOTE:** \_\_\_\_\_

If the free play cannot be adjusted here, adjust it at the throttle lever side of the cable.

**Second step:**

- Pull back the adjuster cover ④.
- Loosen the locknut ⑤.
- Turn the adjuster ⑥ in or out until the correct free play is obtained.

Turning in	Free play is increased.
Turning out	Free play is decreased.

- Tighten the locknut ⑤.
- Push in the adjuster cover ④.

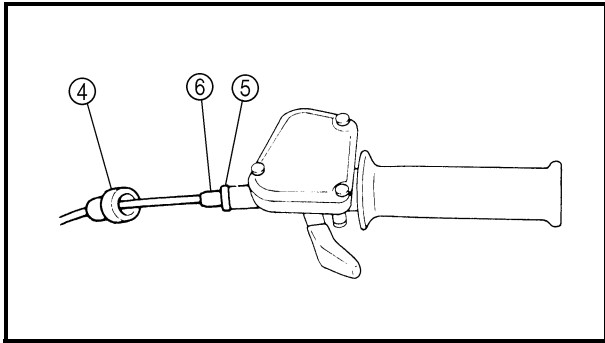

**⚠ WARNING** \_\_\_\_\_

After adjusting the free play, turn the handlebar to the right and left to make sure that the engine idling speed does not increase.

\*\*\*\*\*

## ADJUSTING THE SPEED LIMITER

The speed limiter keeps the carburetor throttle from becoming fully-opened even when the throttle lever is applied to the maximum position. Screwing in the adjuster stops the engine speed from increasing.

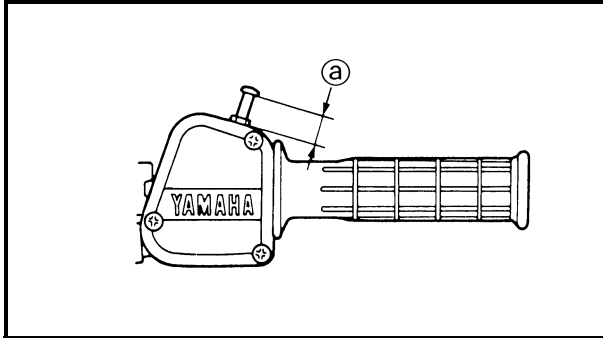

1. Check:

- Speed limiter length ①
- Out of specification → Adjust.

	<b>Speed limiter length:</b> 12 mm (0.47 in)
---	---

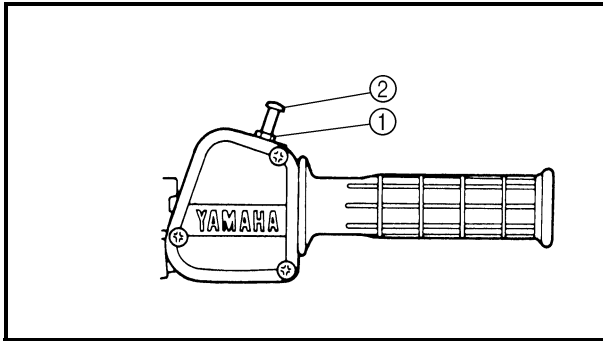

2. Adjust:

- Speed limiter length

\*\*\*\*\*

### Speed limiter length adjustment steps:

- Loosen the locknut ①.
- Turn the adjuster ② in or out until the specified speed limiter length is obtained.

Turning in	Speed limiter length is decreased.
Turning out	Speed limiter length is increased.

- Tighten the locknut.

### **⚠ WARNING**

- Particularly for a beginner rider, the speed limiter should be screwed in completely. Screw it out little by little as their riding technique improves. Never remove the speed limiter for a beginning rider.
- For proper throttle lever operation do not turn out the adjuster more than 12 mm (0.47 in). Also, always adjust the throttle lever free play to 3 ~ 5 mm (0.12 ~ 0.20 in).

\*\*\*\*\*

# ADJUSTING THE STARTER CABLE

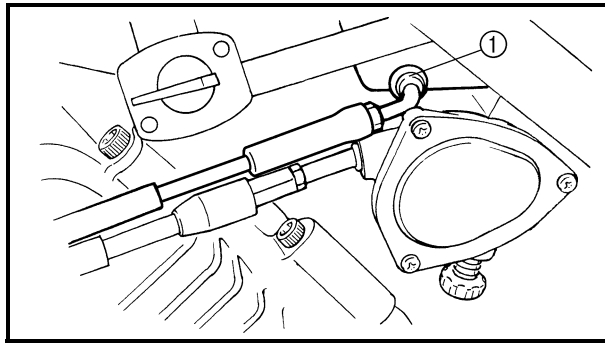

## ADJUSTING THE STARTER CABLE

1. Adjust:

- Starter cable

\*\*\*\*\*

### Adjustment steps:

- Disconnect the starter cable ① from the carburetor body.

### NOTE:

Do not remove the starter plunger ② from the starter cable.

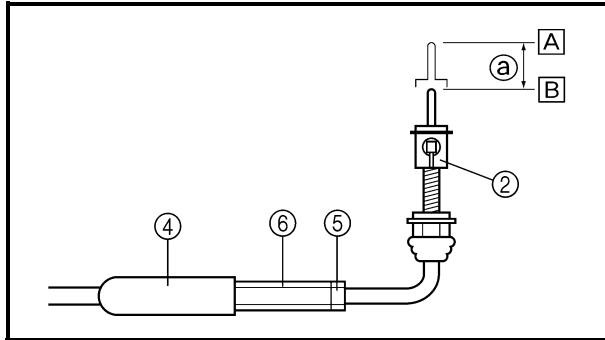

- Measure the starter plunger stroke distance ① of the starter lever ③ fully close-to-fully open position.

If the distance is out of specification adjust it as described below.

	<b>Starter plunger stroke distance ①:</b> <b>15 mm (0.59 in)</b>
--	---

Ⓐ Fully closed position

Ⓑ Fully open position

- Pull back the boot ④.
- Loosen the locknut ⑤.
- Turn the adjuster ⑥ in or out until the correct distance is obtained.

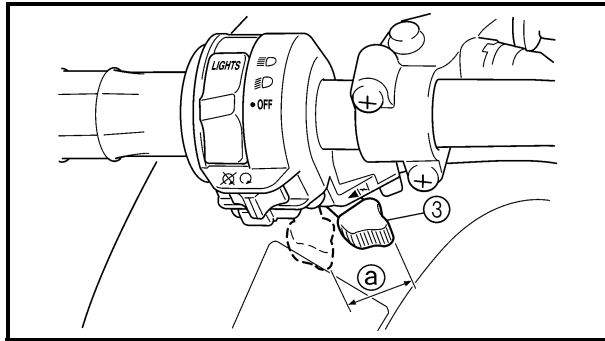

Turning in	Distance increased.
Turning out	Distance decreased.

- Tighten the locknut ⑤.
- Push in the boot ④.
- Connect the starter cable.

### ⚠ WARNING

After adjusting the cable, turn the handlebar to right to left, and make sure that the engine idling speed does not increase.

\*\*\*\*\*

## CHECKING THE SPARK PLUG

1. Remove:

- Spark plug

2. Check:

- Spark plug type  
Incorrect → Replace.

**Standard spark plug:  
DPR8EA-9/NGK**

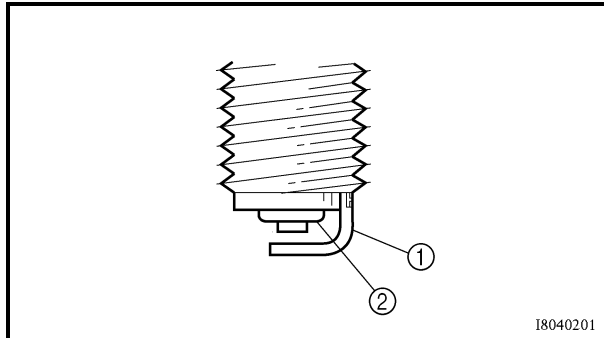

3. Check:

- Electrode ①  
Wear/damage → Replace.
  - Insulator ②  
Abnormal color → Replace.  
Normal color is a medium-to-light tan color.
4. Clean the spark plug with a spark plug cleaner or wire brush.

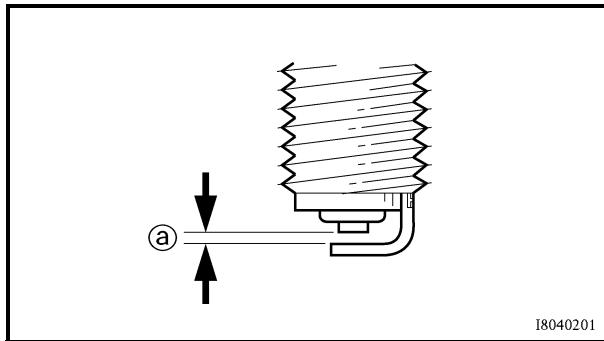

5. Measure:

- Plug gap ①  
Use a wire gauge or feeler gauge.  
Out of specification → Regap.

	<b>Spark plug gap: 0.8 ~ 0.9 mm (0.031 ~ 0.035 in)</b>
---	--

6. Tighten:

- Spark plug  **18 Nm (1.8 m • kg, 13 ft • lb)**

**NOTE:** \_\_\_\_\_

Before installing a spark plug, clean the gasket surface and plug surface.



## CHECKING THE IGNITION TIMING

**NOTE:** \_\_\_\_\_

Engine idling speed and throttle cable free play should be adjusted properly before checking the ignition timing.

1. Attach:

- Tachometer
- Timing light  
(to spark plug lead)



**Timing light:**  
P/N. YM-33277-A, 90890-03141

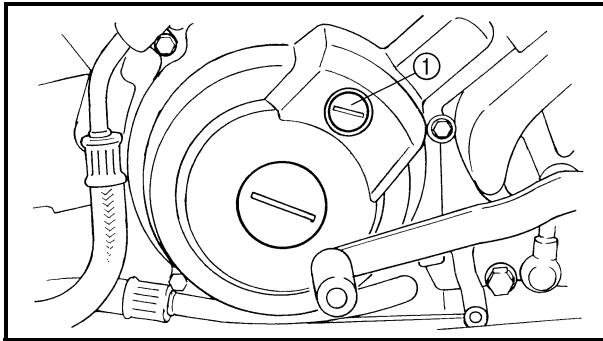

2. Check:

- Ignition timing

\*\*\*\*\*

**Checking steps:**

- Warm up the engine and keep it at the specified speed.



**Engine speed:**  
**1,450 ~ 1,550 r/min**

- Remove the timing mark accessing screw ①.
- Visually check the stationary pointer ② to verify it is within the required firing range ③ indicated on the flywheel.

Incorrect firing range → Check the pulser coil assembly.

- Install the timing mark accessing screw.

\*\*\*\*\*

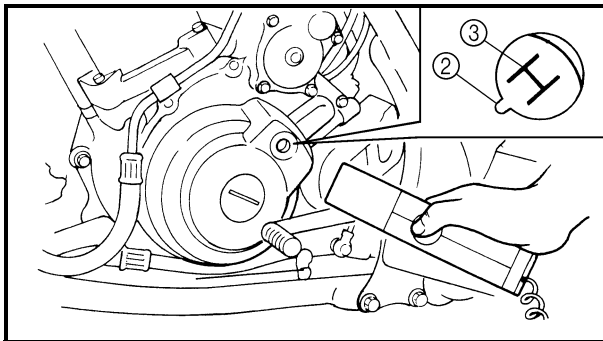

3. Detach:

- Timing light
- Tachometer

## MEASURING THE COMPRESSION PRESSURE

**NOTE:**

Insufficient compression pressure will result in a loss of performance.

1. Check:

- Valve clearance  
Out of specification → Adjust.  
Refer to “ADJUSTING THE VALVE CLEARANCE”.

2. Start the engine and let it warm up for several minutes.

3. Stop the engine.

4. Remove:

- Spark plug

5. Attach:

- Adapter
- Compression gauge ①

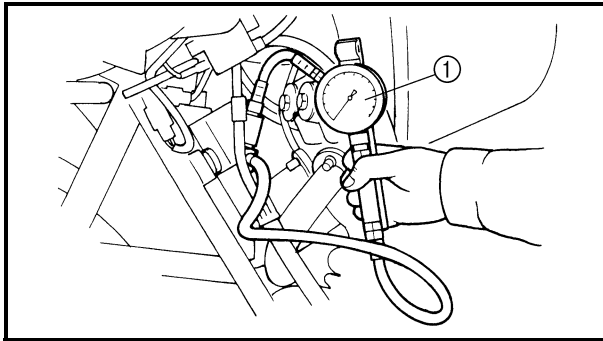

**Compression gauge:**  
P/N. YU-33223, 90890-03081  
**Adapter:**  
P/N. YU-33223-3, 90890-04082

6. Measure:

- Compression pressure  
Above the maximum pressure:  
Inspect the cylinder head, valve surfaces, and piston crown for carbon deposits.  
Below the minimum pressure:  
Squirt a few drops of oil into the affected cylinder and measure again.
- Refer to the table below.

Compression pressure (with oil introduced into cylinder)	
Reading	Diagnosis
Higher than without oil	Worn or damaged piston, rings or cylinder wall.
Same as without oil	Defective valves or cylinder head gasket.

**Compression pressure (at sea level):**  
**Standard:**  
1,250 kPa (12.5 kg/cm<sup>2</sup>, 181 psi)  
**Minimum:**  
1,050 kPa (10.5 kg/cm<sup>2</sup>, 149 psi)  
**Maximum:**  
1,350 kPa (13.5 kg/cm<sup>2</sup>, 192 psi)

\*\*\*\*\*

**Measurement steps:**

- Crank over the engine with the electric starter (be sure the battery is fully charged) with the throttle fully-open until the compression reading on the gauge stabilizes.

**⚠ WARNING**

**When cranking the engine, ground the spark plug lead to prevent sparking.**

\*\*\*\*\*

**7. Install:**

- Spark plug  **18 Nm (1.8 m • kg, 13 ft • lb)**

**CHECKING THE ENGINE OIL LEVEL**

1. Place the machine on a level surface.
2. Start the engine, warm it up until the engine oil has reached a normal temperature of 60 °C (140 °F), let it continue to idle for ten seconds, and then turn the engine off.

**NOTE:**

To achieve the proper engine oil temperature for an accurate oil level reading, the engine must have first completely cooled down, and then warmed up again for several minutes to normal operating temperature.

# CHECKING THE ENGINE OIL LEVEL/ CHANGING THE ENGINE OIL

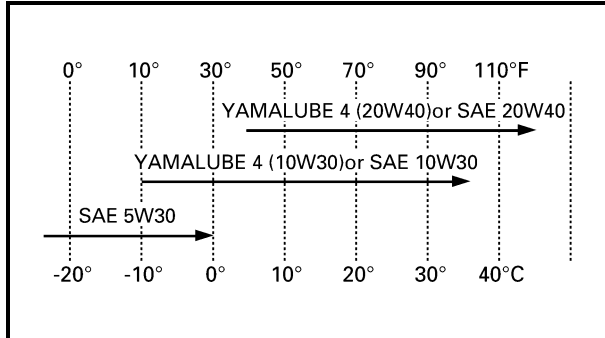
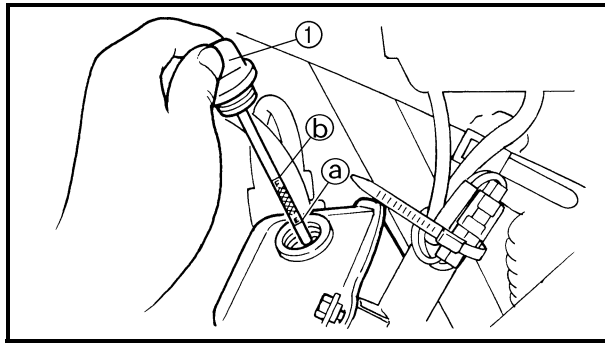
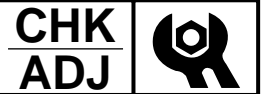

### 3. Check:

- Engine oil level  
Oil level should be between the minimum level mark (a) and the maximum level mark (b).  
Low oil level → Add oil to the proper level.

### NOTE:

- Wait a few minutes until the oil settles before inspecting the oil level.
- Do not screw the dipstick (1) in when inspecting the oil level.



**Recommended oil:**  
Follow the left chart.

### NOTE:

Recommended oil classification:  
API Service "SE", "SF", "SG" type or equivalent (e.g. "SF-SE-CC", "SF-SE-SD" etc.)

### CAUTION:

- Do not add any chemical additives. Engine oil also lubricates the clutch and additives could cause clutch slippage.
- Do not allow foreign material to enter the crankcase.

4. Start the engine and let it warm up for several minutes.
5. Stop the engine and inspect the oil level again.

### NOTE:

Wait a few minutes until the oil settles before inspecting the oil level.

## CHANGING THE ENGINE OIL

### 1. Remove:

- Engine skid plate  
Refer to "SEAT, FENDERS AND FUEL TANK".
2. Start the engine and let it warm up for several minutes.
  3. Stop the engine and place a container under the engine oil drain bolt.

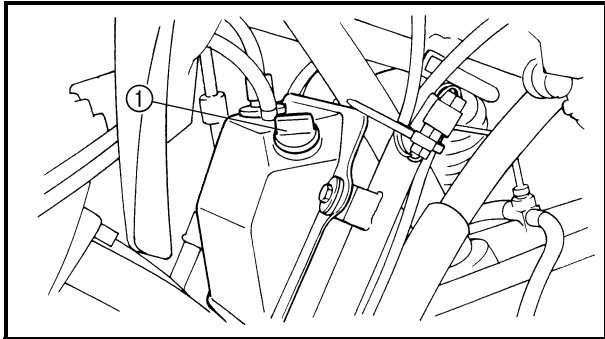

- 4.Remove:
- Dipstick ①

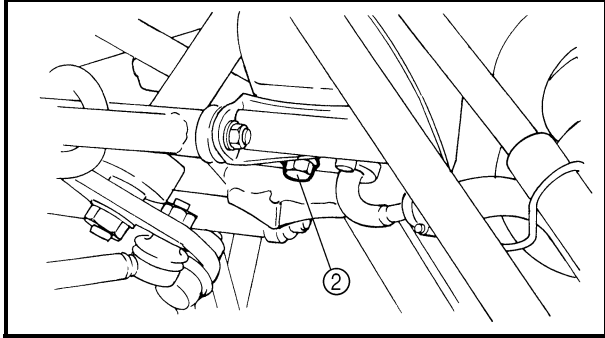

- Engine oil drain bolt (oil tank) ②

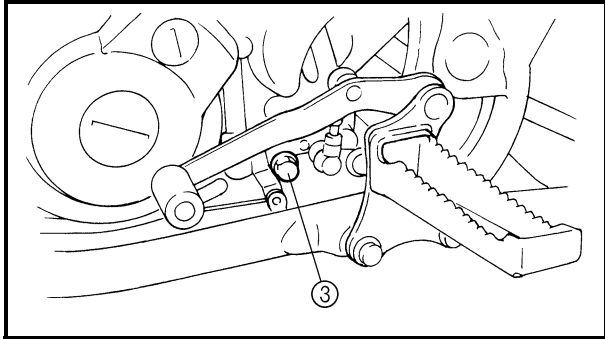

- Engine oil drain bolt (crankcase) ③  
Drain the engine oil from the oil tank and crankcase.

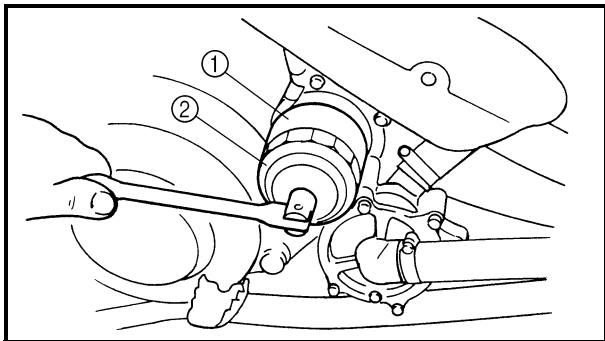

5.If the oil filter cartridge is also to be replaced, perform the following procedure.

\*\*\*\*\*

**Replacement steps:**

- Remove the oil filter cartridge ① with an oil filter wrench ②.



**Oil filter wrench:**  
P/N. YM-01469, 90890-01469

- Apply a thin coat of engine oil to the O-ring ③ of the new oil filter cartridge.

**CAUTION:**

**Make sure that the O-ring ③ is properly seated in the groove of the oil filter cartridge.**

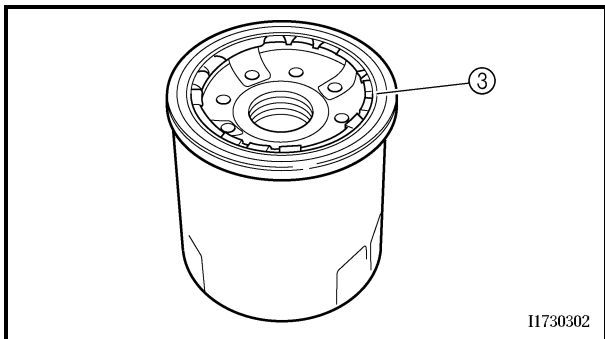

I1730302

- Tighten the new oil filter cartridge to specification with an oil filter wrench.

	<b>Oil filter cartridge:</b> <b>17 Nm (1.7 m • kg, 12 ft • lb)</b>
---	---

\*\*\*\*\*

6. Install:

- Engine oil drain bolt (crankcase)

	<b>30 Nm (3.0 m • kg, 22 ft • lb)</b>
---	---------------------------------------

- Engine oil drain bolt (oil tank)

	<b>25 Nm (2.5 m • kg, 18 ft • lb)</b>
---	---------------------------------------

7. Fill:

- Oil tank  
(with the specified amount of the recommended engine oil)

	<b>Quantity:</b> <b>Total amount:</b> <b>2.3 L (2.02 Imp qt, 2.43 US qt)</b> <b>Periodic oil replacement:</b> <b>1.9 L (1.67 Imp qt, 2.01 US qt)</b> <b>With oil filter cartridge replacement:</b> <b>1.95 L (1.72 Imp qt, 2.06 US qt)</b>
---	--

**NOTE:** \_\_\_\_\_

- Pour the engine oil in several stages.
- First, pour in 1.75 L (1.54 Imp qt, 1.85 US qt) of oil, and then start the engine and rev it 3 to 5 times. Stop the engine, and then pour in the remainder of the specified amount.

**CAUTION:** \_\_\_\_\_

**When starting the engine make sure the dipstick is securely fitted into the oil tank.**

8. Install:

- Dipstick

9. Warm up the engine for a few minutes, then stop the engine.

10. Check:

- Engine  
(for engine oil leaks)
- Oil level  
Refer to “CHECKING THE ENGINE OIL LEVEL”.

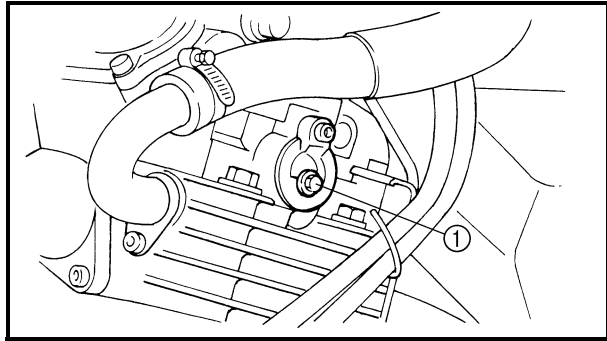

11. Check:

- Engine oil pressure

\*\*\*\*\*

- Slightly loosen the oil gallery bolt ①.
- Start the engine and keep it idling until engine oil starts to seep from the oil gallery bolt. If no engine oil comes out after one minute, turn the engine off so that it will not seize.
- Check the engine oil passages, the oil filter cartridge and the oil pump for damage or leakage.  
Refer to "OIL PUMP" in CHAPTER 5.
- Start the engine after solving the problem(s) and check the engine oil pressure again.
- Tighten the oil gallery bolt to specification.



**Oil gallery bolt:  
7 Nm (0.7 m • kg, 5.1 ft • lb)**

\*\*\*\*\*

12. Install:

- Engine skid plate  
Refer to "SEAT, FENDERS AND FUEL TANK".

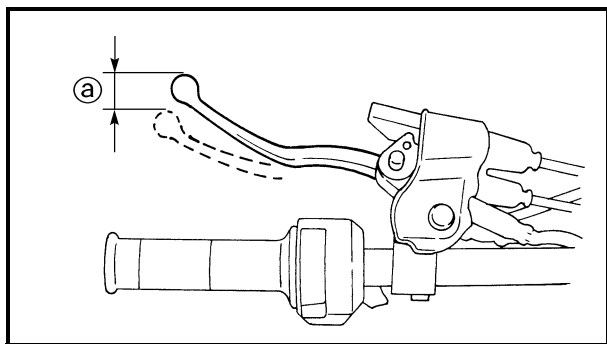

**ADJUSTING THE CLUTCH CABLE**

1. Check:

- Clutch lever free play ①  
Out of specification → Adjust.



**Clutch lever free play  
(at the clutch lever end):  
5 ~ 10 mm (0.20 ~ 0.39 in)**

# ADJUSTING THE CLUTCH CABLE/ CLEANING THE AIR FILTER

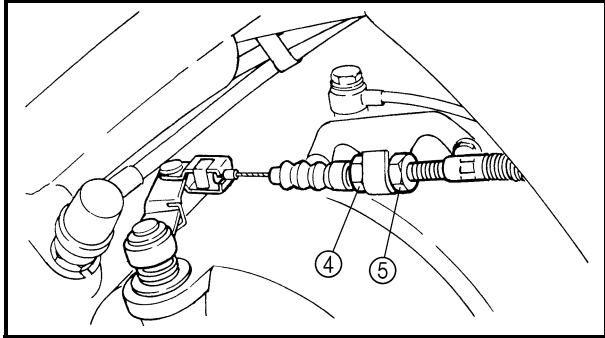
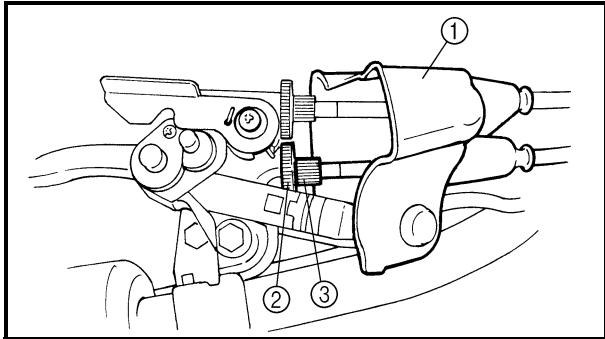

## 2.Adjust:

- Clutch lever free play

\*\*\*\*\*

### Adjustment steps:

- Pull the rubber cover ① off.
- Loosen the locknut ② and finger tighten the adjusting bolt ③.
- Loosen the locknut ④.
- Turn the adjusting nut ⑤ until the clutch lever free play is within the specified limits.



**Clutch lever free play  
(at the clutch lever end):  
5 ~ 10 mm (0.20 ~ 0.39 in)**

- Tighten the locknut ④.

### NOTE:

If the specified clutch lever free play cannot be obtained on it, use the adjusting bolt ③.

- Turn the adjusting bolt ③ until the clutch lever free play is within the specified limits.
- Tighten the locknut ②.
- Pull the rubber cover ① in.

\*\*\*\*\*

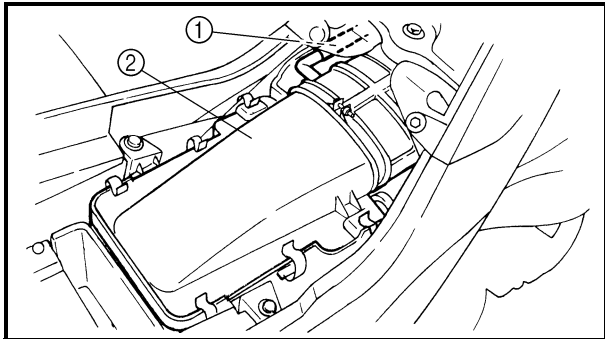
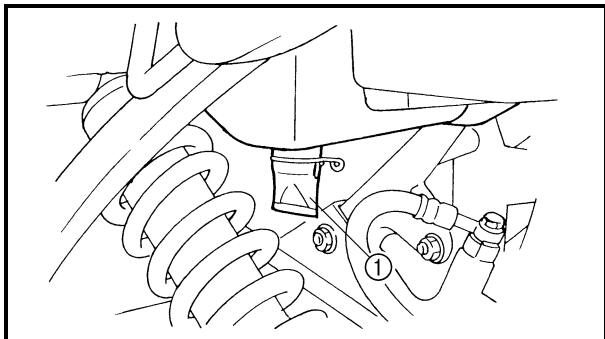

## CLEANING THE AIR FILTER

### NOTE:

There is a check hose ① at the bottom of the air filter case. If dust and/or water collects in this hose, clean the air filter element and air filter case.

### 1.Remove:

- Seat  
Refer to "SEAT, FENDERS AND FUEL TANK".

### 2.Disconnect:

- Crankcase breather hose ①

### 3.Remove:

- Air filter case cover ②



# CLEANING THE AIR FILTER

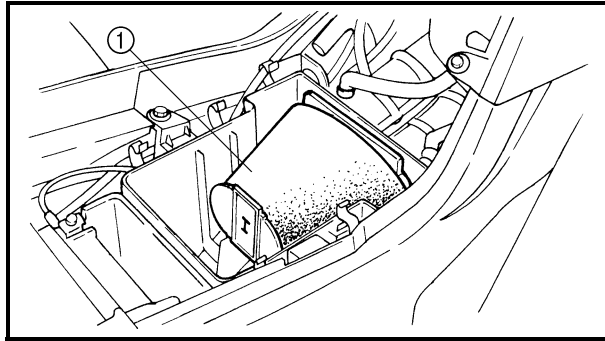

- 4.Remove:
- Air filter element assembly ①
  - Air filter element cap ②
  - Air filter element ③

**NOTE:**

When removing the air filter element, rotate the air filter element cap 1/4 of a turn and remove the element.

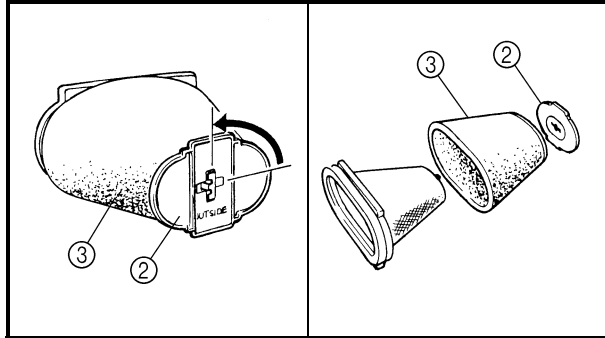

**CAUTION:**

Never operate the engine with the air filter element removed. This will allow unfiltered air to enter, causing rapid wear and possible engine damage. Additionally, operation without the filter element will affect carburetor tuning with subsequent poor performance and possible engine overheating.

5.Check:

- Air filter element  
Damaged → Replace.

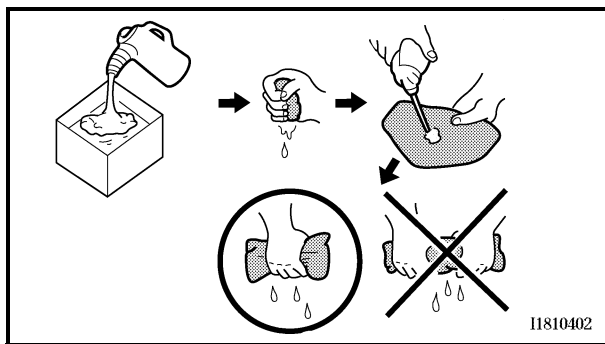

6.Clean:

- Air filter element

\*\*\*\*\*

**Cleaning steps:**

- Wash the element gently, but thoroughly in solvent.

**⚠ WARNING**

Use a cleaning solvent which is designed to clean parts only. Never use gasoline or low flash point solvents as they may cause a fire or explosion.

- Squeeze the excess solvent out of the element and let it dry.

**CAUTION:** \_\_\_\_\_

Do not twist or wring out the element. This could damage the foam material.

- Apply engine oil to the element.
- Squeeze out the excess oil.

**NOTE:** \_\_\_\_\_

The element should be wet but not dripping.

\*\*\*\*\*

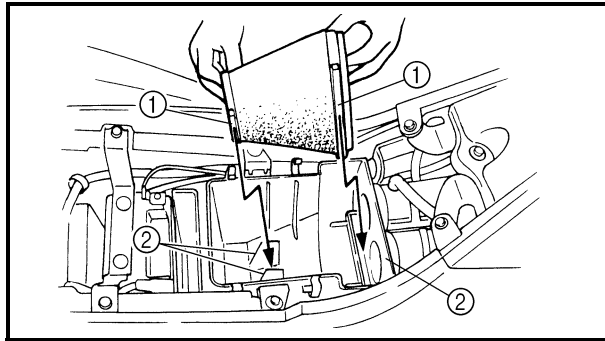

7. Install:

- Air filter element
- Air filter case cover

**NOTE:** \_\_\_\_\_

- Insert the lobes ① on the filter element into the receptacles ② on the filter case.
- To prevent air leaks make sure that the sealing surface of the element matches the sealing surface of the case.

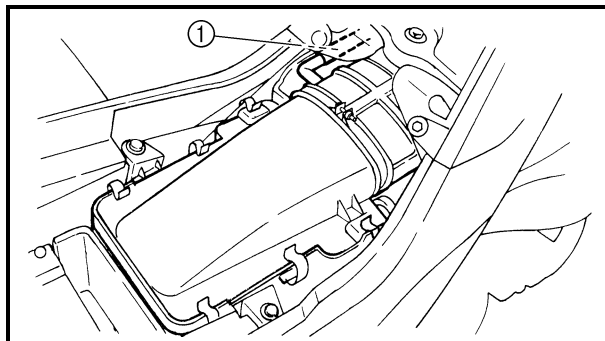

8. Connect:

- Crankcase breather hose ①

9. Install:

- Seat  
Refer to "SEAT, FENDERS AND FUEL TANK".

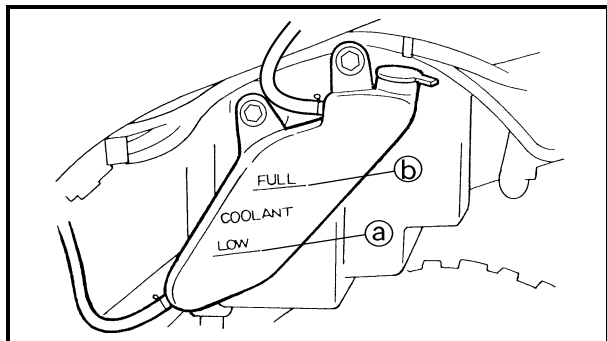

## CHECKING THE COOLANT LEVEL

1. Place the machine on a level surface.
2. Check:

- Coolant level  
The coolant level should be between the minimum level mark (a) and maximum level mark (b).  
Below the minimum level mark → Add the recommended coolant to the proper level.

### CAUTION:

- Adding water instead of coolant lowers the antifreeze content of the coolant. If water is used instead of coolant, check and if necessary, correct the antifreeze concentration of the coolant.
- Use only distilled water. However, soft water may be used if distilled water is not available.

3. Start the engine, warm it up for several minutes, and then turn it off.

4. Check:

- Coolant level

### NOTE:

Before inspecting the coolant level, wait a few minutes until the coolant has settled.

## CHANGING THE COOLANT

1. Remove:

- Front panel  
Refer to "SEAT, FENDERS AND FUEL TANK".

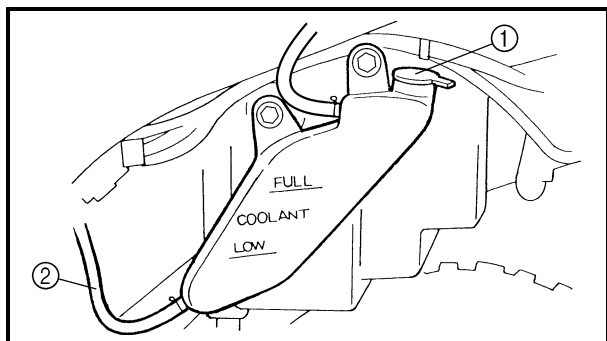

2. Remove:

- Coolant reservoir cap (1)

3. Disconnect:

- Coolant reservoir hose (2)

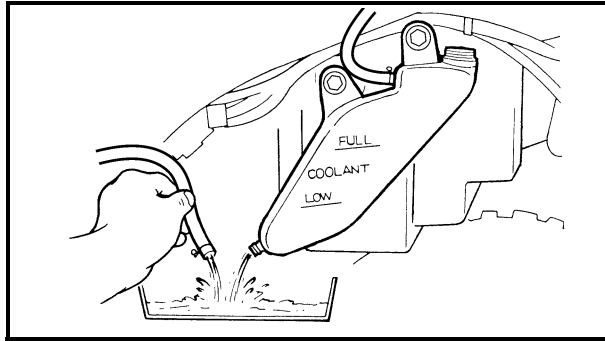

4. Drain:
- Coolant  
(from the coolant reservoir)
5. Connect:
- Coolant reservoir hose

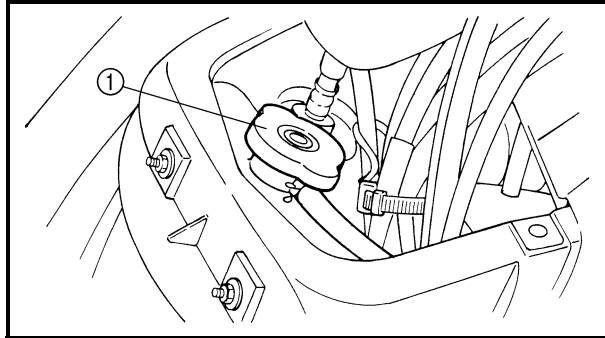

6. Remove:
- Radiator cap ①

**⚠ WARNING**

A hot radiator is under pressure. Therefore, do not remove the radiator cap when the engine is hot. Scalding hot fluid and steam may be blown out, which could cause serious injury. When the engine has cooled, open the radiator cap as follows:

Place a thick rag or a towel over the radiator cap and slowly turn the radiator cap counterclockwise toward the detent to allow any residual pressure to escape. When the hissing sound has stopped, turn the radiator cap counterclockwise while pressing down on it and then remove it.

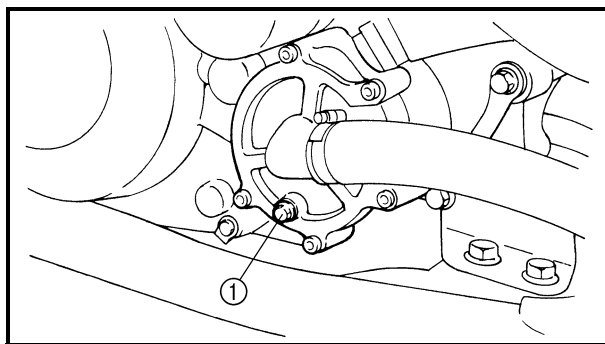

7. Remove:
- Coolant drain bolt ①  
(along with the copper washer)
8. Drain:
- Coolant

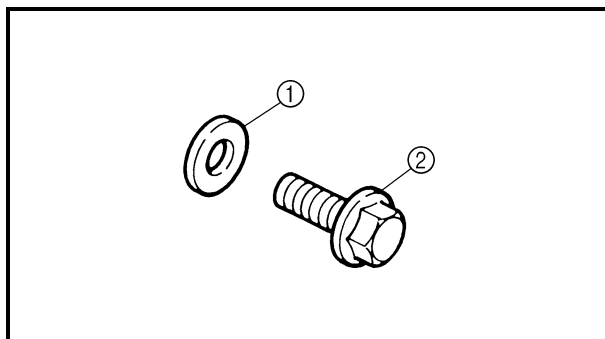

9. Check:
- Copper washer ① **New**
  - Coolant drain bolt ②  
Damage → Replace.
10. Install:
- Coolant drain bolt

10 Nm (1.0 m • kg, 7.2 ft • lb)

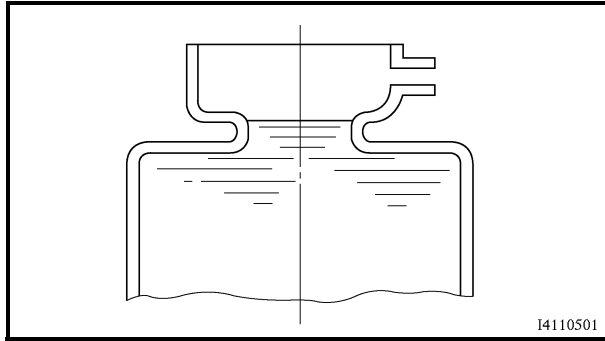

**11.Fill:**

- Cooling system  
(with the specified amount of the recommended coolant)



**Recommended antifreeze:**  
High-quality ethylene glycol antifreeze containing corrosion inhibitors for aluminum engines

**Mixing ratio:**

1:1 (antifreeze:water)

**Quantity:**

**Total amount:**

1.3 L

(1.14 Imp qt, 1.37 US qt)

**Coolant reservoir capacity:**

0.29 L

(0.26 Imp qt, 0.31 US qt)

**Handling notes for coolant**

Coolant is potentially harmful and should be handled with special care.

**⚠ WARNING**

- If coolant splashes in your eyes, thoroughly wash them with water and consult a doctor.
- If coolant splashes on your clothes, quickly wash it away with water and then with soap and water.
- If coolant is swallowed, induce vomiting and get immediate medical attention.

**CAUTION:**

- Adding water instead of coolant lowers the antifreeze content of the coolant. If water is used instead of coolant, check, and if necessary, correct the antifreeze concentration of the coolant.
- Use only distilled water. However, soft water may be used if distilled water is not available.
- If coolant comes into contact with painted surfaces, immediately wash them with water.
- Do not mix different types of antifreeze.

**12.Install:**

- Radiator cap

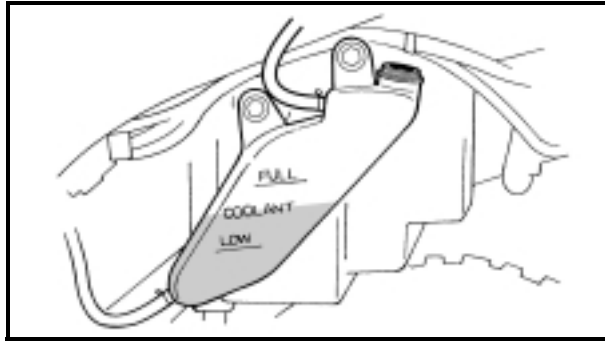

13.Fill:

- Coolant reservoir  
(with the recommended coolant to the proper level)

14.Install:

- Coolant reservoir cap

15.Start the engine, warm it up for several minutes, and then turn it off.

16.Check:

- Coolant level

Refer to "CHECKING THE COOLANT LEVEL".

**NOTE:** \_\_\_\_\_

Before inspecting the coolant level, wait a few minutes until the coolant has settled.

---

17.Install:

- Front panel

Refer to "SEAT, FENDERS AND FUEL TANK".

# CHECKING THE COOLANT TEMPERATURE WARNING LIGHT/CLEANING THE SPARK ARRESTER

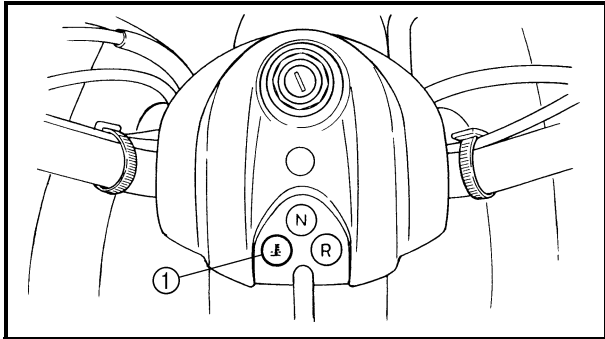

## CHECKING THE COOLANT TEMPERATURE WARNING LIGHT

① Coolant temperature warning light

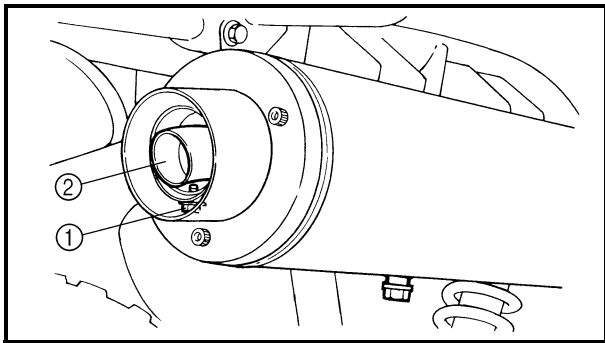
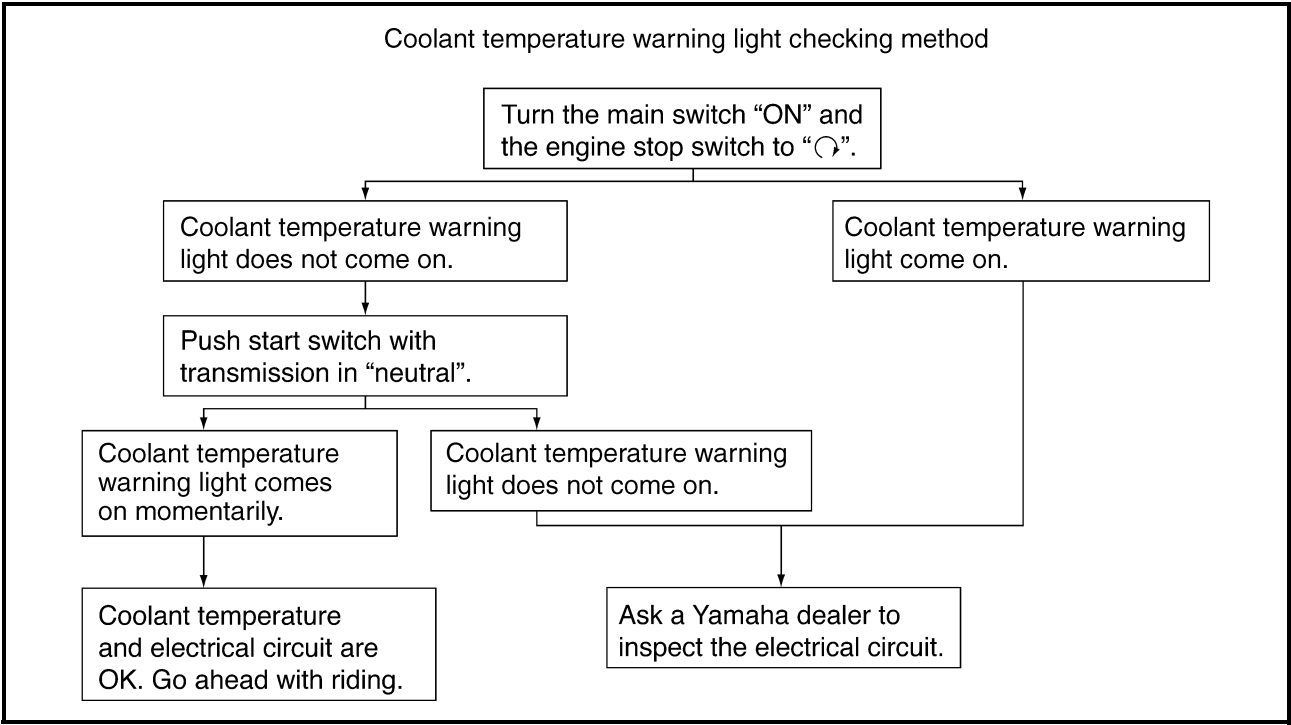

## CLEANING THE SPARK ARRESTER

1. Clean:

- Spark arrester

\*\*\*\*\*

Cleaning steps:

### ⚠ WARNING

- Select a well-ventilated area free of combustible materials.
- Always let the exhaust system cool before performing this operation.
- Do not start the engine when removing the tailpipe from the muffler.

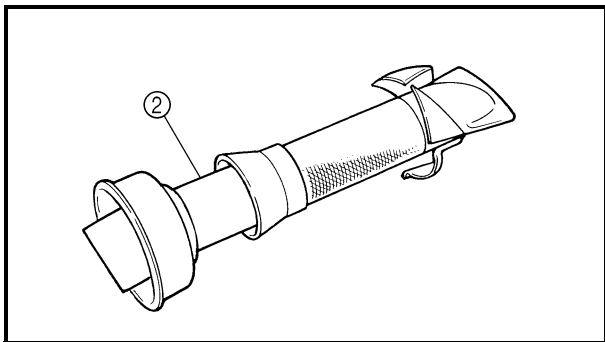

- Remove the bolt ①.
- Remove the tailpipe ② by pulling it out of the muffler.

## CLEANING THE SPARK ARRESTER

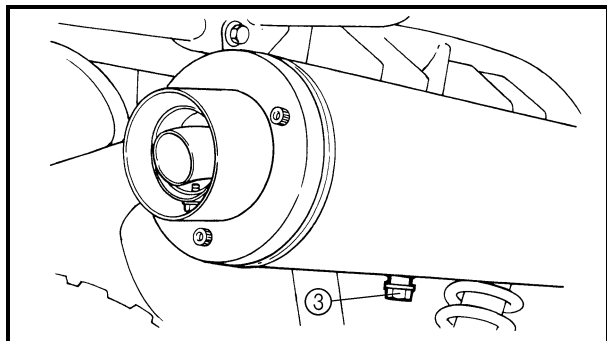

- Tap the tailpipe lightly with a soft-face hammer or suitable tool, then use a wire brush to remove any carbon deposits from the spark arrester portion of the tailpipe and the inner contact surfaces of the muffler.
- Insert the tailpipe into the muffler and align the bolt holes.
- Insert the bolt and tighten it.
- Remove the purging bolt ③.
- Start the engine and rev it up approximately twenty times while momentarily creating exhaust system back pressure by blocking the end of the muffler with a shop towel.
- Stop the engine and allow the exhaust pipe to cool.
- Install the purging bolt ③ and tighten it.

\*\*\*\*\*



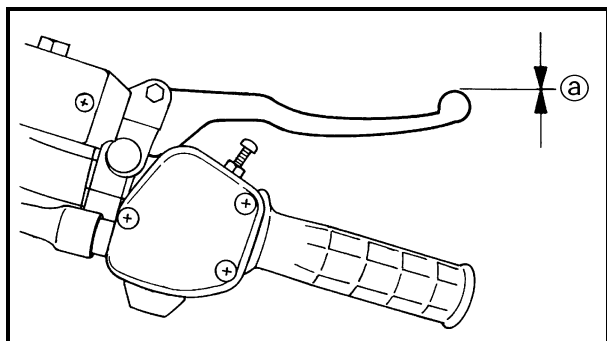

**CHASSIS**

**ADJUSTING THE FRONT BRAKE**

1. Check:

- Brake lever free play (a)
  - Out of specification → Bleed the front brake system.
  - Refer to “AIR BLEEDING (HYDRAULIC BRAKE SYSTEM)”.



**Brake lever free play (at the brake lever end):**  
**0 mm (0 in)**

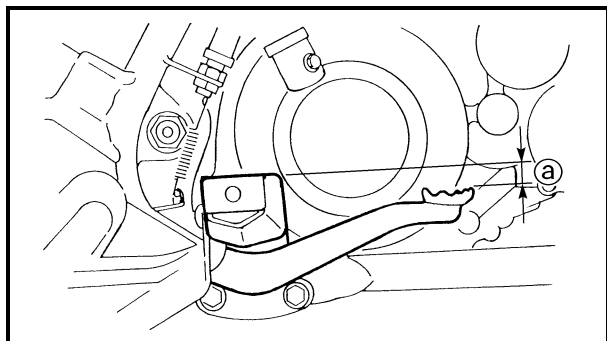

**ADJUSTING THE REAR BRAKE**

1. Check:

- Rear brake pedal height (a)
  - Out of specification → Adjust.



**Rear brake pedal height:**  
**4 mm (0.16 in)**

2. Adjust:

- Rear brake pedal height

\*\*\*\*\*

**Adjustment steps:**

- Loosen the locknut (1).
- Turn the adjusting bolt (2) until the brake pedal height is within the specified limits.

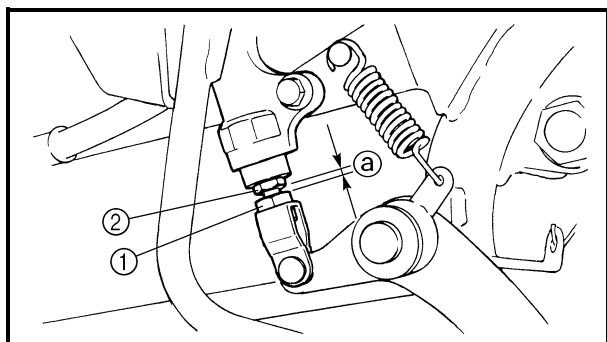

**Brake pedal height:**  
**4 mm (0.16 in)**

- Tighten the locknut (1).

**NOTE:**

When adjusting the brake pedal height make sure the locknut-to-adjusting bolt clearance (a) does not exceed 2.2 ~ 3.2 mm (0.09 ~ 0.13 in).



**⚠ WARNING**

After this adjustment is performed, lift the rear wheels off the ground by placing a block under the engine, and spin the rear wheels to ensure there is no brake drag. If any brake drag is noticed perform the above steps again.

\*\*\*\*\*

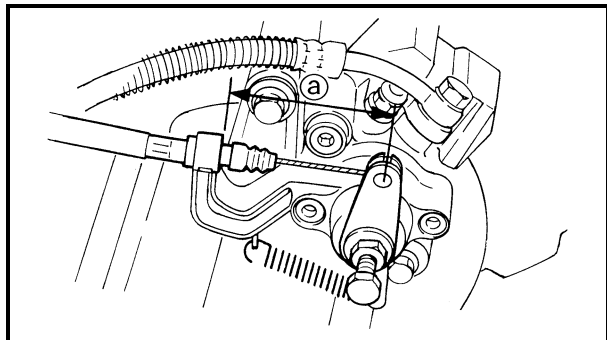

**ADJUSTING THE PARKING BRAKE**

1. Check:

- Parking brake cable end length ①
- Out of specification → Adjust.



**Parking brake cable end length:**  
64 ~ 68 mm (2.5 ~ 2.7 in)

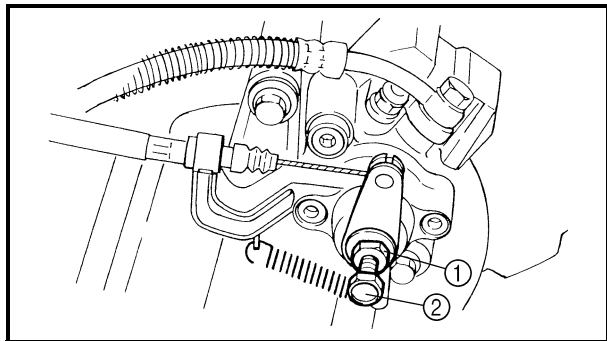

2. Adjust:

- Parking brake cable end length

\*\*\*\*\*

**Adjustment steps:**

- Loosen the locknut ① and adjusting bolt ②.
- Pull the rubber cover ③ off.
- Loosen the locknut ④.
- Turn the adjuster ⑤ in or out until the specified brake cable end length is obtained.
- Tighten the locknut ④.
- Slowly turn the adjusting bolt ② clockwise until resistance is felt.
- Turn it 1/8 counterclockwise.
- Tighten the locknut ①.

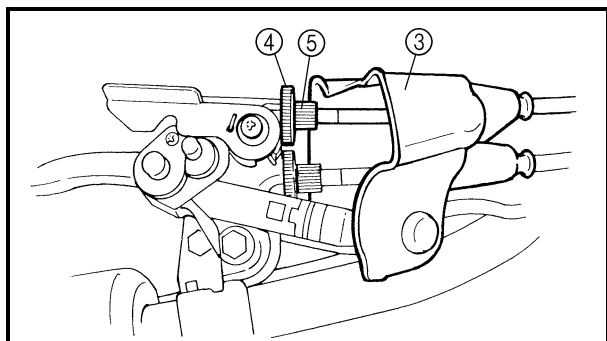

**Locknut:**  
16 Nm (1.6 m • kg, 11 ft • lb)

- Check the parking brake cable free play ①.



**Free play (parking brake cable):**  
0 mm (0 in)  
at parking brake lever pivot

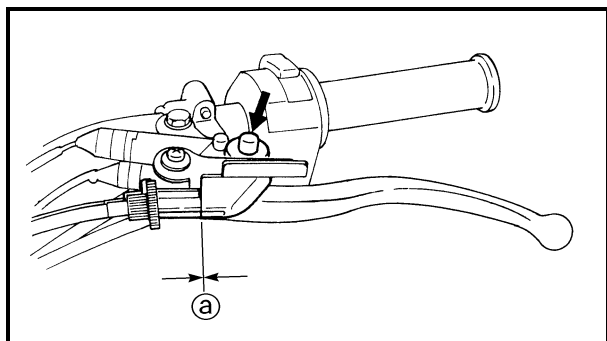

- If the free play is incorrect, adjust the free play by adjuster ⑤.
- Pull the rubber cover ③ in.

**⚠ WARNING**

After this adjustment is performed, lift the rear wheels off the ground by placing a block under the engine, and spin the rear wheels to ensure there is no brake drag. If any brake drag is noticed perform the above steps again.

\*\*\*\*\*

## CHECKING THE BRAKE FLUID LEVEL

1. Place the machine on a level surface.

**NOTE:**

When inspecting the brake fluid level, make sure that the top of the brake fluid reservoir top is horizontal.

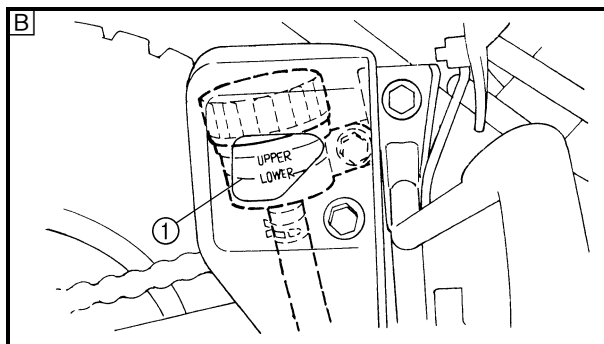
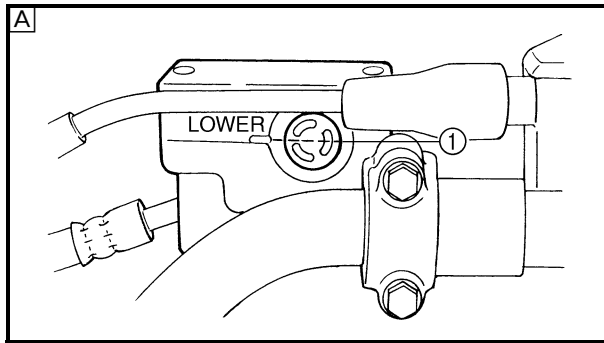

2. Check:

- Brake fluid level  
Fluid level is below the “LOWER” level line  
① → Add the recommended brake fluid to the proper level.

	<b>Recommended brake fluid: DOT 4</b>
---	---

- A** Front brake
- B** Rear brake

**CAUTION:**

Brake fluid may erode painted surfaces or plastic parts. Always clean up spilled fluid immediately.

**⚠ WARNING**

- Use only the designated quality brake fluid: Otherwise, the rubber seals may deteriorate, causing leakage and poor brake performance.
- Refill with the same type of brake fluid: Mixing fluids may result in a harmful chemical reaction and lead to poor performance.
- Be careful that water does not enter the master cylinder when refilling. Water will significantly lower the boiling point of the fluid and may result in a vapor lock.

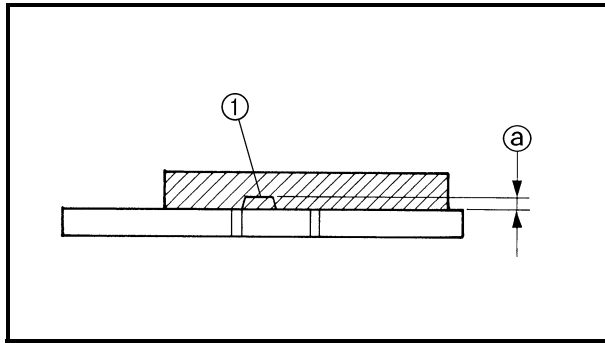

### CHECKING THE FRONT BRAKE PAD

1. Remove:

- Front wheels

2. Check:

- Brake pad

Wear indicators ① almost in contact with the brake disc → Replace the brake pads as a set.

Refer to “FRONT AND REAR BRAKES” in CHAPTER 4.



**Brake pad wear limit ②:**  
**1 mm (0.04 in)**

3. Operate the brake lever.

4. Install:

- Front wheels

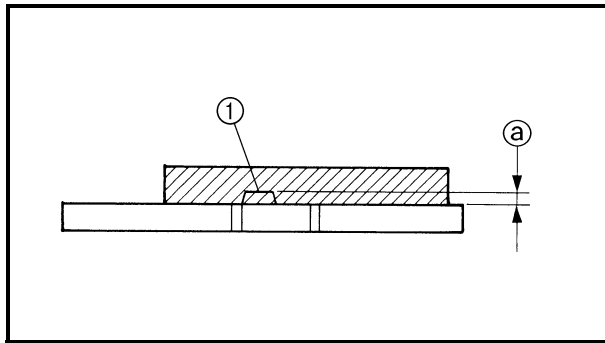

### CHECKING THE REAR BRAKE PAD

1. Check:

- Brake pad

Wear indicators ① almost in contact with the brake disc → Replace the brake pads as a set.

Refer to “FRONT AND REAR BRAKES” in CHAPTER 4.



**Brake pad wear limit ②:**  
**1 mm (0.04 in)**

2. Operate the brake pedal.

### ADJUSTING THE REAR BRAKE LIGHT SWITCH

**NOTE:** \_\_\_\_\_

The rear brake light switch is operated by movement of the brake pedal.

The rear brake light switch is properly adjusted when the brake light comes on just before the braking effect starts.

# ADJUSTING THE REAR BRAKE LIGHT SWITCH/ CHECKING THE BRAKE HOSE

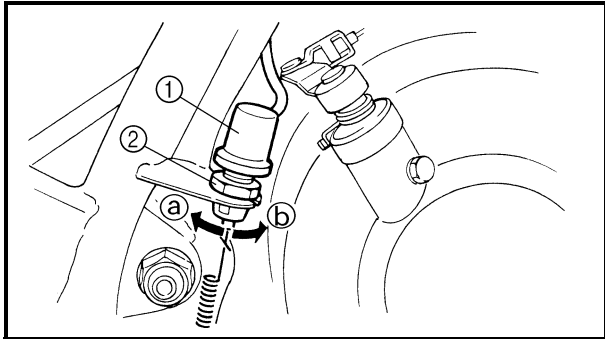

1. Check:
  - Rear brake light operation timing  
Incorrect → Adjust.
2. Adjust:
  - Rear brake light operation timing

\*\*\*\*\*

- Hold the main body ① of the rear brake light switch so that it does not rotate and turn the adjusting nut ② in direction ③ or ④ until the rear brake light comes on at the proper time.

Direction ③	Brake light comes on sooner.
Direction ④	Brake light comes on later.

\*\*\*\*\*

## CHECKING THE BRAKE HOSE

1. Remove:
  - Seat
  - Front fender  
Refer to "SEAT, FENDERS AND FUEL TANK".

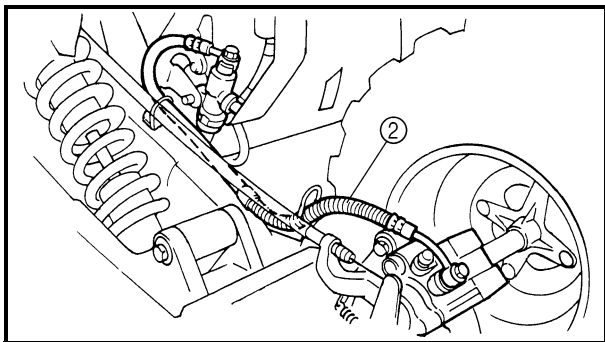
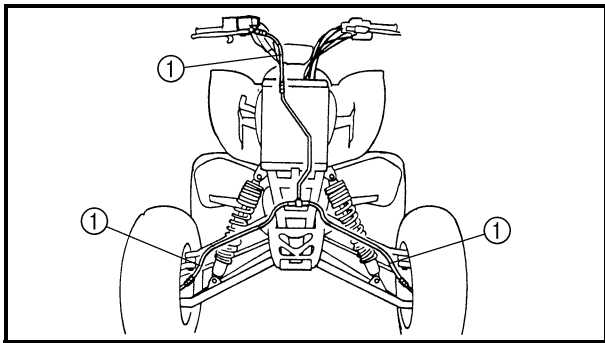

2. Check:
  - Front brake hoses ①
  - Rear brake hoses ②  
Cracks/wear/damage → Replace.
3. Check:
  - Brake hose clamp  
Loosen → Tighten.
4. Hold the machine in an upright position and apply the front or rear brake.
5. Check:
  - Brake hoses  
Apply the brake lever several times.  
Fluid leakage → Replace the hose.  
Refer to "FRONT AND REAR BRAKE" in CHAPTER 4.

6. Install:

- Front fender
- Seat

Refer to “SEAT, FENDERS AND FUEL TANK”.

**BLEEDING THE HYDRAULIC BRAKE SYSTEM**

**⚠ WARNING**

**Bleed the brake system if:**

- The system has been disassembled.
- A brake hose or brake pipe have been loosened or removed.
- The brake fluid has been very low.
- The brake operation has been faulty.

**A loss of braking performance may occur if the brake system is not properly bled.**

1. Bleed:

- Brake system

\*\*\*\*\*

**Air bleeding steps:**

- Add the proper brake fluid to the reservoir.
  - Install the diaphragm. Be careful not to spill any fluid or allow the reservoir to overflow.
  - Connect the clear plastic hose ① tightly to the caliper bleed screw ②.
- A** Front  
**B** Rear
- Place the other end of the hose into a container.
  - Slowly apply the brake lever or pedal several times.
  - Pull the lever in or push down on the pedal and hold it.
  - Loosen the bleed screw and allow the lever or pedal to travel towards its limit.
  - Tighten the bleed screw when the lever or pedal limit has been reached, then release the lever or pedal.
  - Repeat steps (e) to (h) until all the air bubbles have disappeared from the fluid.

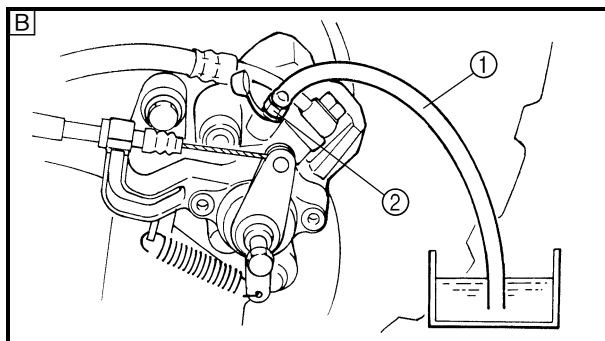
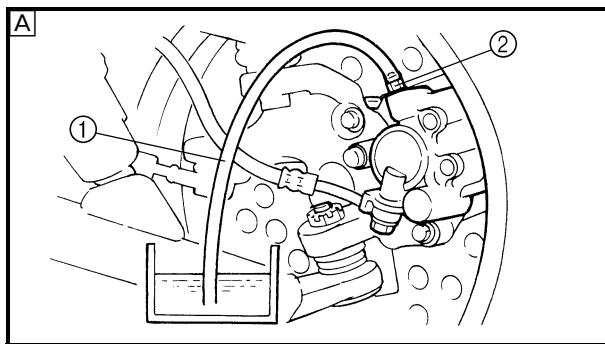

j. Tighten the bleed screw.

	<b>Bleed screw:</b> <b>6 Nm (0.6 m • kg, 4.3 ft • lb)</b>
---	--

**NOTE:** \_\_\_\_\_  
If bleeding is difficult, it may be necessary to let the brake fluid settle for a few hours. Repeat the bleeding procedure when the tiny bubbles in the system have disappeared.

k. Add brake fluid to the proper level.  
Refer to “CHECKING THE BRAKE FLUID LEVEL”.

**⚠ WARNING** \_\_\_\_\_  
**Check the operation of the brake after bleeding the brake system.**

\*\*\*\*\*

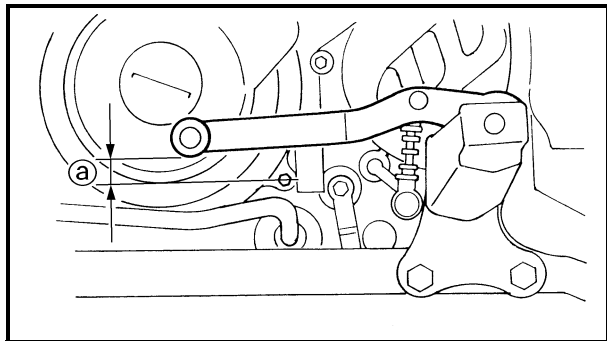

**ADJUSTING THE SHIFT PEDAL**

1. Check:  
● Shift pedal height ①  
Out of specification → Adjust.

	<b>Shift pedal height:</b> <b>22 mm (0.89 in)</b>
---	--

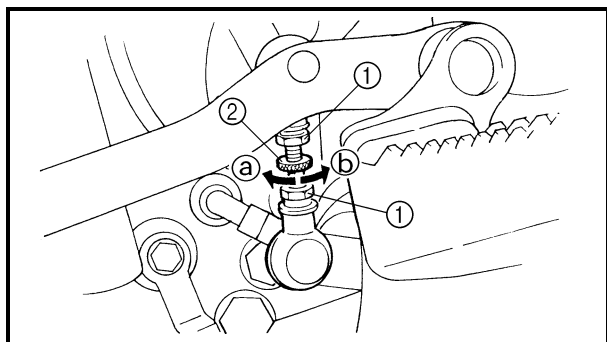

2. Adjust:  
● Shift pedal height

\*\*\*\*\*

**Adjustment steps:**  
● Loosen the locknuts ①.  
● Turn the adjusting rod ② in direction ① or ② until the specified shift pedal position obtained.

<b>Direction ①</b>	<b>Shift pedal position is down.</b>
<b>Direction ②</b>	<b>Shift pedal position is up.</b>

● Tighten the locknuts.

	<b>Locknut:</b> <b>8 Nm (0.8 m • kg, 5.8 ft • lb)</b>
---	--

\*\*\*\*\*

# ADJUSTING THE REVERSE CONTROL CABLE/ ADJUSTING THE DRIVE CHAIN SLACK

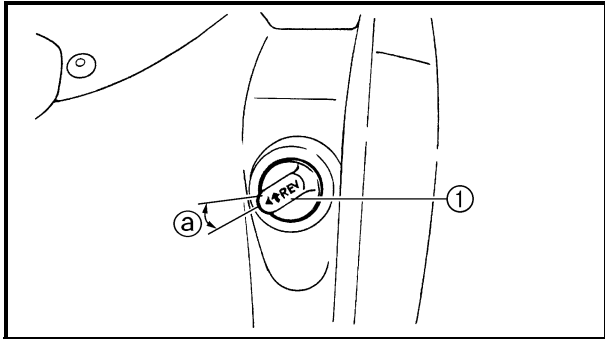

## ADJUSTING THE REVERSE CONTROL CABLE

1. Check:

- Reverse knob free play (a)  
Out of specification → Adjust.

	<b>Reverse knob free play:</b> 0 mm (0 in)
--	---

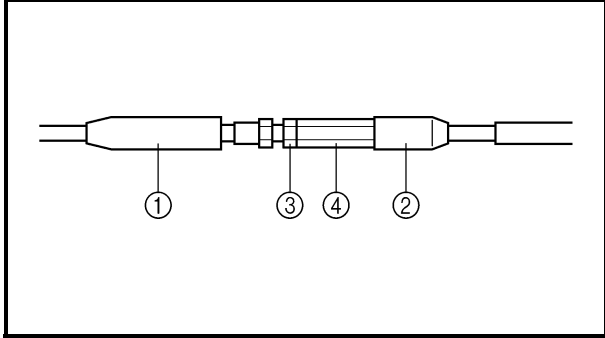

2. Adjust:

\*\*\*\*\*

### Adjustment steps:

- Pull the boots (1) and (2) off.
- Loosen the locknut (3).
- Turn the adjusting nut (4) until the reverse control cable (5) is taut or the length (a) is 135 mm (5.31 in).

### NOTE:

Be sure to hold the reverse shift lever (6) when make this adjustment so that it does not move.

- Tighten the locknut (3).
- Pull the boots (1) and (2) in.

\*\*\*\*\*

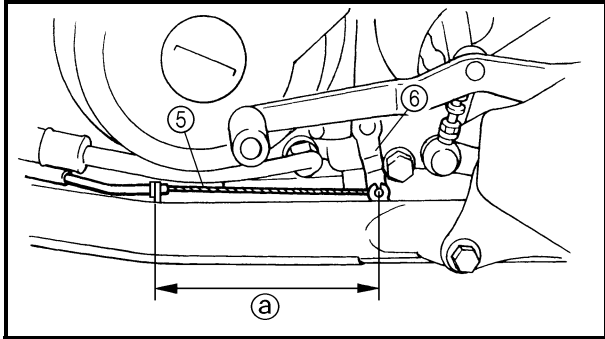

## ADJUSTING THE DRIVE CHAIN SLACK

### NOTE:

The drive chain slack must be checked at the tightest point on the chain.

### CAUTION:

A drive chain that is too tight will overload the engine and other vital parts, and one that is too loose can skip and damage the swingarm or cause an accident. Therefore, keep the drive chain slack within the specified limits.

1. Elevate the rear wheels by placing the suitable stand under the frame.
2. Rotate the rear wheel several times and check the drive chain to locate its tightest point.



# ADJUSTING THE DRIVE CHAIN SLACK

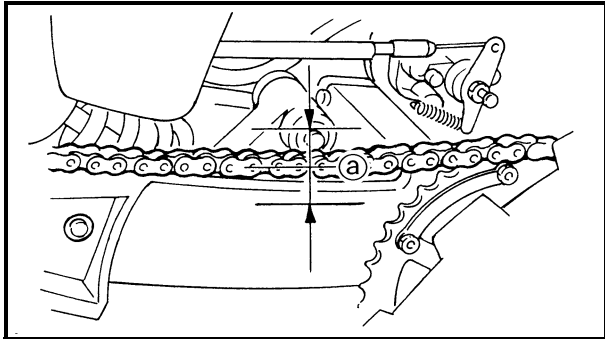

### 3.Measure:

- Drive chain slack (a)
- Out of specification → Adjust.

	<b>Drive chain slack:</b> 30 ~ 45 mm (1.18 ~ 1.77 in)
---	--

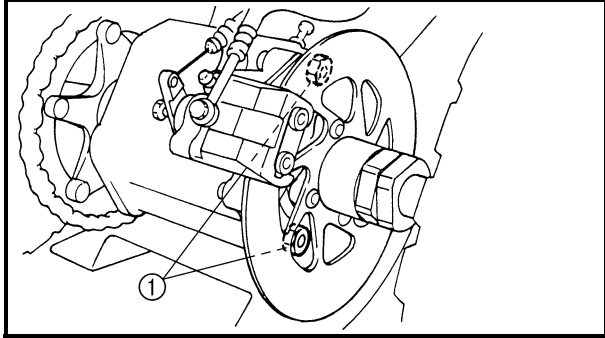

### 4.Adjust:

- Drive chain slack

\*\*\*\*\*

#### Adjustment steps:

- Loosen the hub nuts (1).
- Loosen the locknuts (2).
- Turn both adjusting bolts (3) in direction (a) or (b) until the specified drive chain slack is obtained.

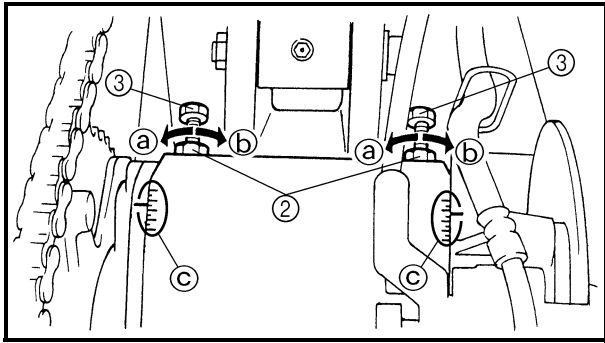

Direction (a)	Drive chain slack is reduced.
Direction (b)	Drive chain slack is increased.

#### NOTE:

To maintain the proper axle alignment, adjust both sides evenly. (There are marks (c) on each side of hub.)

#### CAUTION:

Excessive chain slack will overload the engine and other vital parts; keep the slack within the specified limits.

- If the chain slack cannot be adjusted, replace the sprockets and drive chain as a set.
- Tighten the hub nuts and locknuts.

	<b>Hub nut:</b> 90 Nm (9.0 m • kg, 65 ft • lb)
	<b>Locknut (chain puller):</b> 16 Nm (1.6 m • kg, 11 ft • lb)

#### NOTE:

The chain should be cleaned and lubricated after every use of the machine.

\*\*\*\*\*

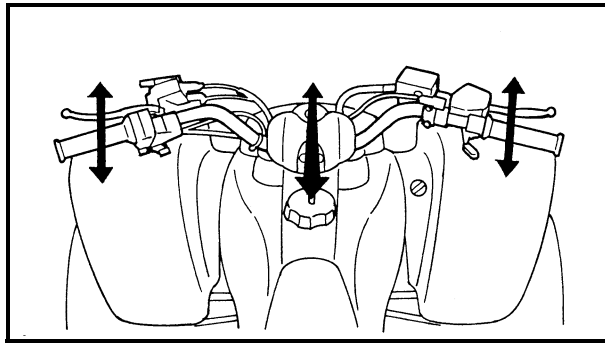

## CHECKING THE STEERING SYSTEM

1. Place the machine on a level surface.

2. Check:

- Steering assembly bushings  
Move the handlebar up and down, and/or back and forth.  
Excessive play → Replace the steering stem bushings.

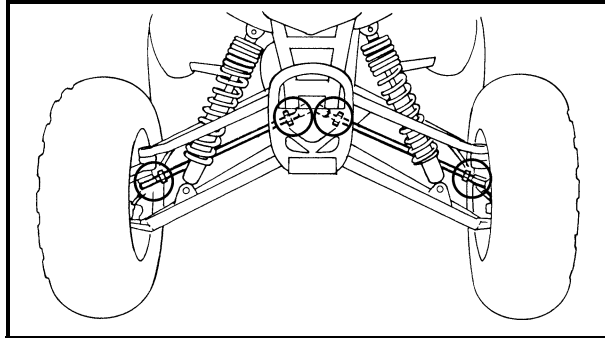

3. Check:

- Tie-rod ends  
Turn the handlebar to the left and/or right until it stops completely, then move the handlebar from the left to the right slightly. Tie-rod end has any vertical play → Replace the tie-rod end(s).

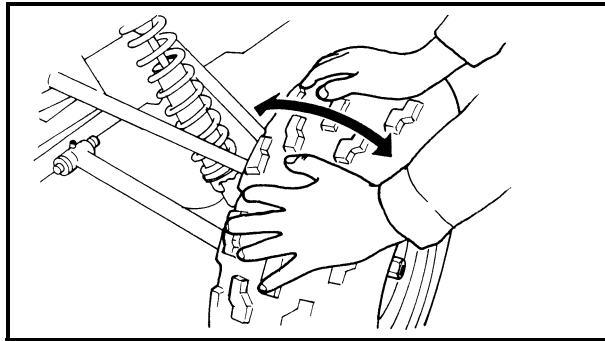

4. Raise the front end of the machine so that there is no weight on the front wheels.

5. Check:

- Ball joints and/or wheel bearings  
Move the wheels laterally back and forth.  
Excessive free play → Replace the front arms (upper and lower) and/or wheel bearings.

## ADJUSTING THE TOE-IN

1. Place the machine on a level surface.

2. Measure:

- Toe-in  
Out of specification → Adjust.



**Toe-in:**  
**0 ~ 10 mm (0 ~ 0.39 in)**

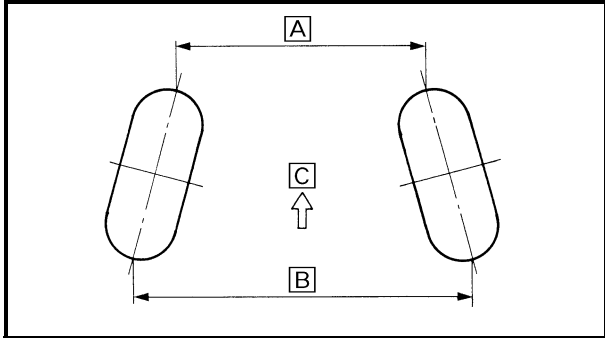
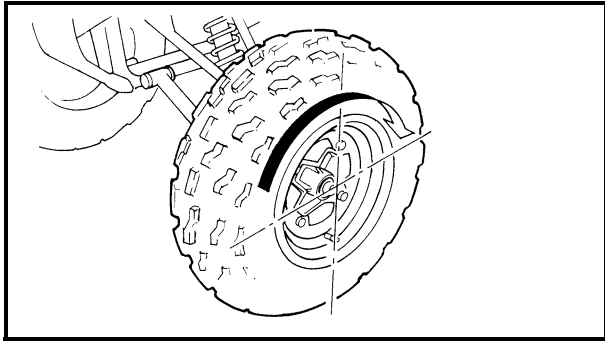

\*\*\*\*\*

### Toe-in measurement steps:

**NOTE:** \_\_\_\_\_  
 Before measuring the toe-in, make sure that the tire pressure is correct.

- Mark both front tire tread centers.
- Raise the front end of the machine so that there is no weight on the front tires.
- Face the handlebar straight ahead.
- Measure the width **A** between the marks.
- Rotate the front tires 180° until the marks are exactly opposite one another.
- Measure the width **B** between the marks.
- Calculate the toe-in using the formula given below.

$$\text{Toe-in} = \text{B} - \text{A}$$

- If the toe-in is incorrect, adjust it.

**C** Forward

\*\*\*\*\*

### 3. Adjust:

- Toe-in

### **⚠ WARNING**

- Be sure that both tie-rods are turned the same amount. If not, the machine will drift right or left even though the handlebar is positioned straight. This may lead to mis-handling and an accident.
- After setting the toe-in to specification, run the machine slowly for some distance with both hands lightly holding the handlebar and check that the handlebar responds correctly. If not, turn either the right or left tie-rod within the toe-in specification.

# ADJUSTING THE TOE-IN/ ADJUSTING THE FRONT SHOCK ABSORBER

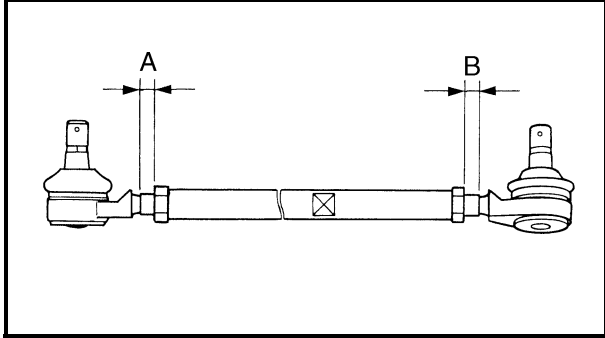
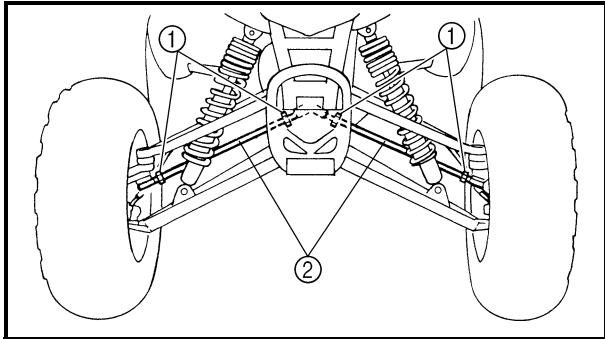

\*\*\*\*\*

### Adjustment steps:

- Mark both tie-rod ends.  
This reference point will be needed during adjustment.
- Loosen the locknuts (tie-rod end) ① of both tie-rods.
- The same number of turns should be given to both the right and left tie-rods ② until the specified toe-in is obtained. This is to keep the length of the rods the same.
- Tighten the rod end locknuts of both tie rods.

	<b>Locknut (rod end):</b> <b>15 Nm (1.5 m • kg, 11 ft • lb)</b>
--	--

**NOTE:** \_\_\_\_\_  
Adjust the rod ends so that A and B are equal.

\*\*\*\*\*

## ADJUSTING THE FRONT SHOCK ABSORBER

### **⚠ WARNING** \_\_\_\_\_

Always adjust both front shock absorber spring preload to the same setting. Uneven adjustment can cause poor handling and loss of stability.

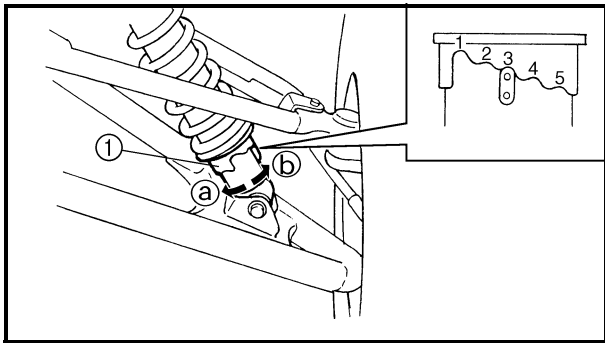

1. Adjust:
- Spring preload  
Turn the adjuster ① in direction ① or ②.

Direction ①	Spring preload is increased (suspension is harder).
Direction ②	Spring preload is decreased (suspension is softer).

<b>Standard position: 3</b> <b>Minimum position: 1</b> <b>Maximum position: 5</b>
---

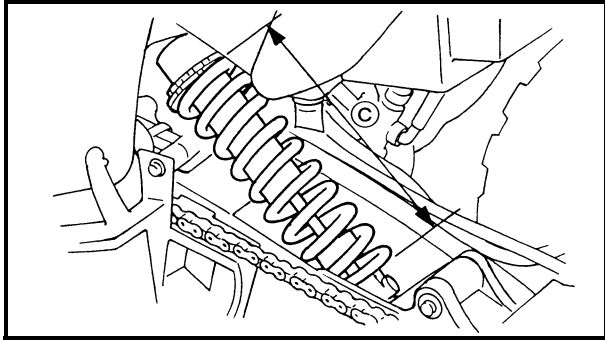
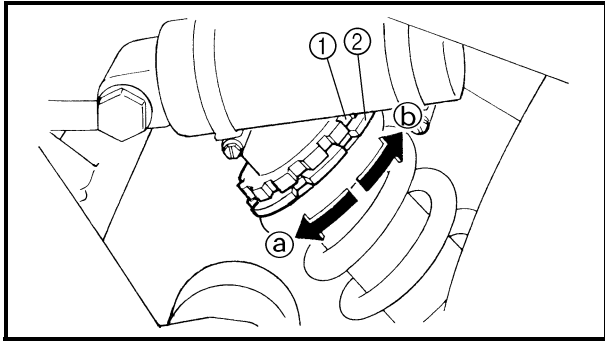

## ADJUSTING THE REAR SHOCK ABSORBER

1. Adjust:

- Spring preload

\*\*\*\*\*

### Adjustment steps:

- Elevate the rear wheels by placing a suitable stand under the frame.
- Loosen the locknut ①.
- Turn the adjusting ring ② in direction ③ or ④.

Direction ③	Spring preload is increased (suspension is harder).
Direction ④	Spring preload is decreased (suspension is softer).

**Adjusting length ⑤:**  
**Standard: 253 mm (9.96 in)**  
**Minimum: 245 mm (9.65 in)**  
**Maximum: 260 mm (10.24 in)**

### NOTE:

- Be sure to remove all dirt and mud from around the locknut and adjusting ring before adjustment.
- The length of the spring (installed) changes 1.5 mm (0.06 in) per turn of the adjuster.

### CAUTION:

**Never attempt to turn the adjusting ring beyond the maximum or minimum setting.**

- Tighten the locknut ①.

**Locknut:**  
**42 Nm (4.2 m • kg, 30 ft • lb)**

### NOTE:

Always tighten the locknut against the adjusting ring, then torque it to specification.

\*\*\*\*\*

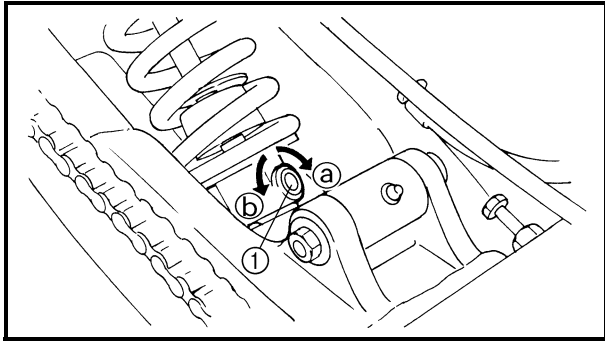

2.Adjust:

- Rebound damping force

\*\*\*\*\*

**Adjustment steps:**

- Turn the adjusting screw ① in direction ① or ②.

Direction ①	Rebound damping force is increased.
Direction ②	Rebound damping force is decreased.

**From the fully turned-in position:**  
**Standard: 10 clicks out**  
**Minimum: 20 clicks out**  
**Maximum: 3 clicks out**

**CAUTION:** \_\_\_\_\_  
 Do not force the adjuster past the minimum or maximum extent of adjustment. The adjuster may be damaged.

\*\*\*\*\*

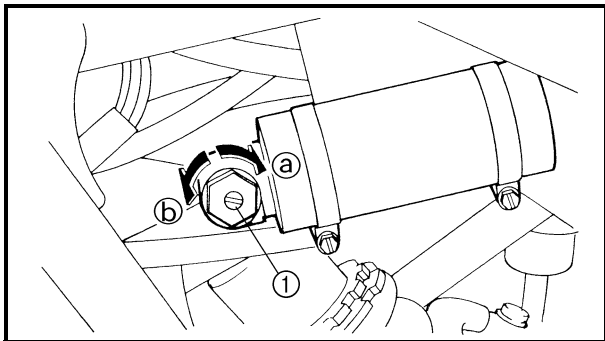

3.Adjust:

- Compression damping force

\*\*\*\*\*

**Adjustment steps:**

- Turn the adjusting screw ① in direction ① or ②.

Direction ①	Compression damping force is increased.
Direction ②	Compression damping force is decreased.

**From the fully turned-out position:**  
**Standard: 7 clicks in**  
**Minimum: 1 click in**  
**Maximum: 12 clicks in**

**CAUTION:**  
Do not forc the adjuster past the minimum or maximum extent of adjustment. The adjuster may be damaged.

\*\*\*\*\*

CHECKING THE TIRE

**⚠ WARNING**

This model is equipped with low pressure tires. It is important that they be inflated correctly and maintained at the proper pressures.

• TIRE CHARACTERISTICS

1)Tire characteristics influence the handling of ATV's. The tires listed below have been approved by Yamaha Motor Co., Ltd. for this model. If other tire combinations are used, they can adversely affect your machine's handling characteristics and are therefore not recommended.

	Manufacturer	Size	Type
Front	DUNLOP	AT21×7-10	KT311 Radial
Rear	DUNLOP	AT20×10-9	KT335 Radial

• TIRE PRESSURE

- 1)Recommended tire pressure  
 Front 27.5 kPa (0.275 kg/cm<sup>2</sup>, 4.0 psi)  
 Rear 27.5 kPa (0.275 kg/cm<sup>2</sup>, 4.0 psi)
- 2)Tire pressure below the minimum specification could cause the tire to dislodge from the rim under severe riding conditions.  
 The following are minimums:  
 Front 24.5 kPa (0.245 kg/cm<sup>2</sup>, 3.5 psi)  
 Rear 24.5 kPa (0.245 kg/cm<sup>2</sup>, 3.5 psi)
- 3)Use no more than  
 Front 250 kPa (2.5 kg/cm<sup>2</sup>, 36 psi)  
 Rear 250 kPa (2.5 kg/cm<sup>2</sup>, 36 psi)  
 when seating the tire beads. Higher pressures may cause the tire to burst. Inflate the tires slowly and carefully. Fast inflation could cause the tire to burst.

- **MAXIMUM LOADING LIMIT**
- 1) Vehicle load limit (total weight of cargo, rider and accessories, and tongue weight): 100 kg (220 lb)

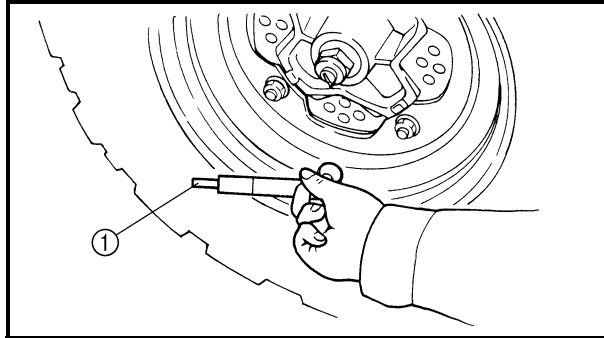

1. Measure:

- Tire pressure (cold tire pressure)  
Out of specification → Adjust.

**NOTE:**

- The low-pressure tire gauge ① is included as standard equipment.
- If dust or the like is stuck to this gauge, it will not provide the correct readings. Therefore, take two measurements of the tire's pressure and use the second reading.

Cold tire pressure	Front	Rear
Standard	27.5 kPa (0.275 kg/cm <sup>2</sup> , 4.0 psi)	27.5 kPa (0.275 kg/cm <sup>2</sup> , 4.0 psi)
Minimum	24.5 kPa (0.245 kg/cm <sup>2</sup> , 3.5 psi)	24.5 kPa (0.245 kg/cm <sup>2</sup> , 3.5 psi)
Maximum	30.5 kPa (0.305 kg/cm <sup>2</sup> , 4.4 psi)	30.5 kPa (0.305 kg/cm <sup>2</sup> , 4.4 psi)

**⚠ WARNING**

Uneven or improper tire pressure may adversely affect the handling of this machine and may cause loss of control.

- Maintain proper tire pressures.
- Set tire pressures when the tires are cold.
- Tire pressures must be equal in both front tires and equal in both rear tires.



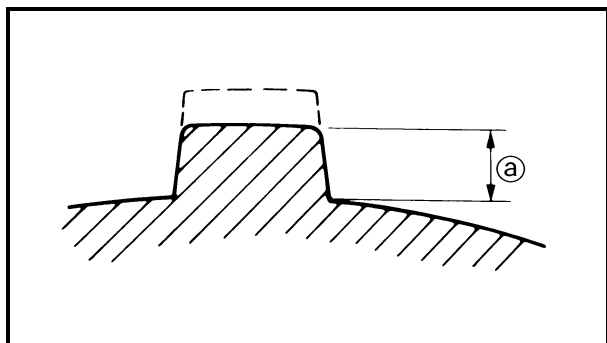

2. Check:

- Tire surfaces  
Wear/damage → Replace.



**Tire wear limit ①:**  
Front and rear: 3.0 mm (0.12 in)

**⚠ WARNING**

It is dangerous to ride with a worn-out tire. When tire wear is out of specification, replace the tire immediately.

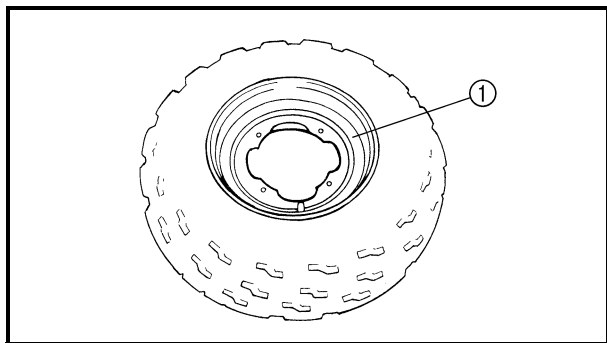

**CHECKING THE WHEEL**

1. Check:

- Wheels ①  
Damage/bends → Replace.

**NOTE:**

Always balance the wheel when a tire or wheel has been changed or replaced.

**⚠ WARNING**

- Never attempt even small repairs to the wheel.
- Ride conservatively after installing a tire to allow it to seat itself properly on the rim.

**CHECKING AND LUBRICATING THE CABLE**

**⚠ WARNING**

A damaged cable sheath may cause corrosion and interfere with the cable movement. An unsafe condition may result so replace a damaged cable as soon as possible.

## CHECKING AND LUBRICATING THE CABLE/ LUBRICATING THE LEVERS AND PEDAL

CHK  
ADJ



1. Check:
  - Cable sheath  
Damage → Replace.
2. Check:
  - Cable operation  
Unsmooth operation → Lubricate or replace.



**Recommended lubricant:**  
Yamaha chain and cable lube or  
Engine oil

**NOTE:** \_\_\_\_\_  
Hold the cable end up and apply several drops  
of lubricant to the cable.

3. Apply:
  - Lithium soap base grease  
(onto end of the cable)

### LUBRICATING THE LEVERS AND PEDAL

1. Lubricate the pivoting parts.



**Recommended lubricant:**  
Lithium soap base grease

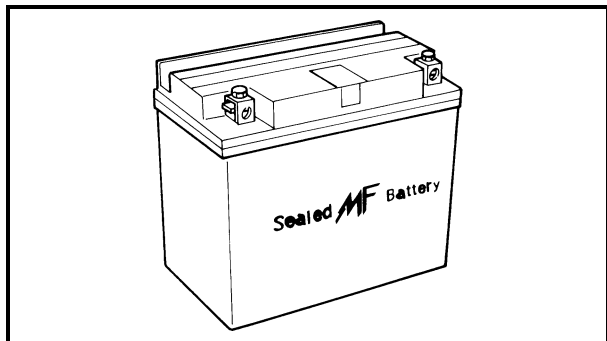

EB305000

**ELECTRICAL****CHECKING THE BATTERY****NOTE:**

Since the MF battery is a sealed type battery, it is not possible to measure the specific gravity of the electrolyte in order to check the charge state of the battery. Therefore the charge of the battery has to be checked by measuring the voltage at the battery terminals.

**CAUTION:****CHARGING METHOD**

- This is a sealed type battery. Never remove the sealing caps. If the sealing caps have been removed, the balance will not be maintained and battery performance will deteriorate.
- Charging time, charging current and charging voltage for the MF battery are different from those of general type batteries. The MF battery should be charged as explained in "CHARGING METHOD". If the battery is overcharged, the electrolyte level will drop considerably. Therefore, take special care when charging the battery.

**⚠ WARNING**

Battery electrolyte is dangerous; it contains sulfuric acid which is poisonous and highly caustic.

Always follow these preventive measures:

- Avoid bodily contact with electrolyte as it can cause severe burns or permanent eye injury.
- Wear protective eye gear when handling or working near batteries.

**Antidote (EXTERNAL):**

- SKIN - Wash with water.
- EYES - Flush with water for 15 minutes and get immediate medical attention.

**Antidote (INTERNAL):**

- Drink large quantities of water or milk followed with milk of magnesia, beaten egg or vegetable oil. Get immediate medical attention.

Batteries generate explosive hydrogen gas. Always follow these preventive measures:

- Charge batteries in a well-ventilated area.
- Keep batteries away from fire, sparks or open flames (e.g., welding equipment, lighted cigarettes, etc.).
- **DO NOT SMOKE** when charging or handling batteries.

**KEEP BATTERIES AND ELECTROLYTE OUT OF REACH OF CHILDREN.**

1. Remove:

- Seat
  - Battery holding bracket
- Refer to “SEAT, FENDERS AND FUEL TANK”.

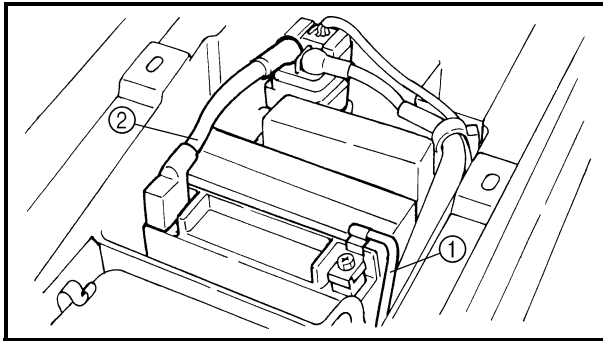

2. Disconnect:

- Battery leads

**CAUTION:**

**First disconnect the negative lead ①, then disconnect the positive lead ②.**

3. Remove:

- Battery

4. Check:

- Battery condition

\*\*\*\*\*

**Battery condition checking steps:**

- Connect a digital voltmeter to the battery terminals.

**Tester (+) lead → battery (+) terminal**  
**Tester (-) lead → battery (-) terminal**

**NOTE:**

The charge state of an MF battery can be checked by measuring the open-circuit voltage (i.e. the voltage when the positive terminal is disconnected).

Open-circuit voltage	Charging time
<b>12.8 V or higher</b>	<b>No charging is necessary.</b>

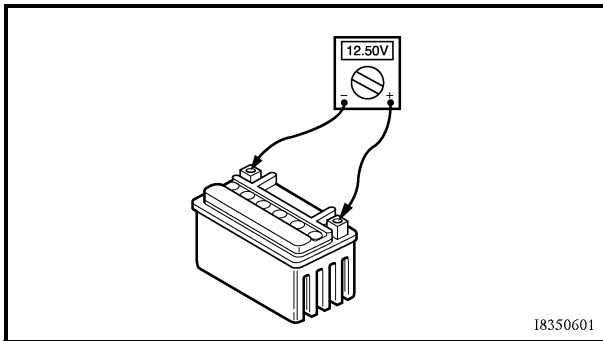

18350601

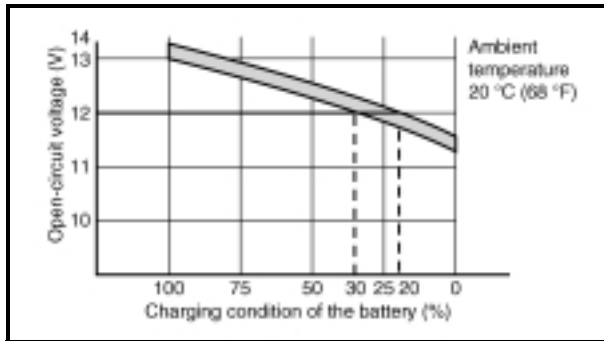
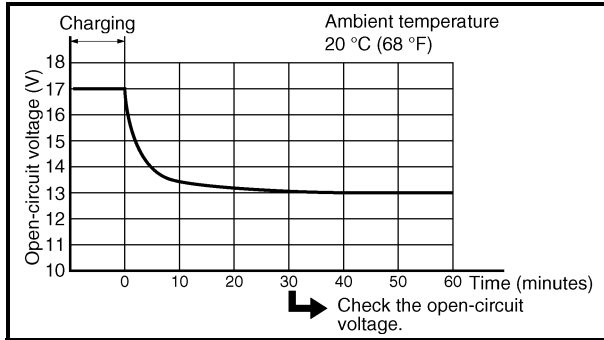
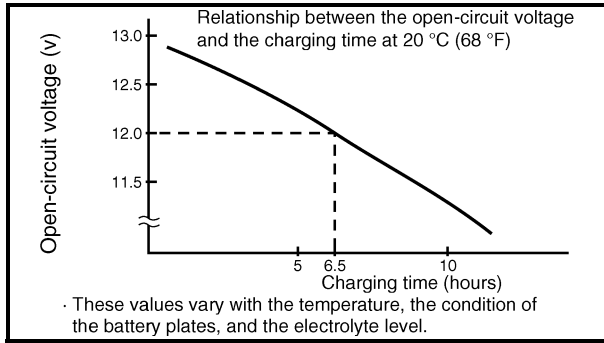

● Check the condition of the battery using the following charts.

**Example:**

- Open-circuit voltage = 12.0 V
- Charging time = 6.5 hours
- Charge condition of the battery = 20 ~ 30%
- Charging method for MF batteries

**CAUTION:**

- If it is impossible to set the standard charging current, be careful not to over-charge.
- When charging the battery, be sure to remove it from the motorcycle. (If charging has to be done with the battery mounted on the motorcycle, be sure to disconnect the wire at the negative terminal.)
- Never remove the sealing caps of an MF battery.
- Make sure that the charging clips are in full contact with the terminal and that they are not shorted together. (A corroded clip on the charger may cause the battery to generate heat in the contact area. A weak clip spring may cause sparks.)
- Before removing the clips from the battery terminals, be sure to turn off the charger's power switch.
- The open-circuit voltage variation for the MF battery, after charging, is shown below. As shown in the figure, the open-circuit voltage stabilizes about 30 minutes after charging has been completed. Therefore, wait 30 minutes after charging is completed before measuring the open-circuit voltage.

\*\*\*\*\*

## Charging method using a variable voltage charger

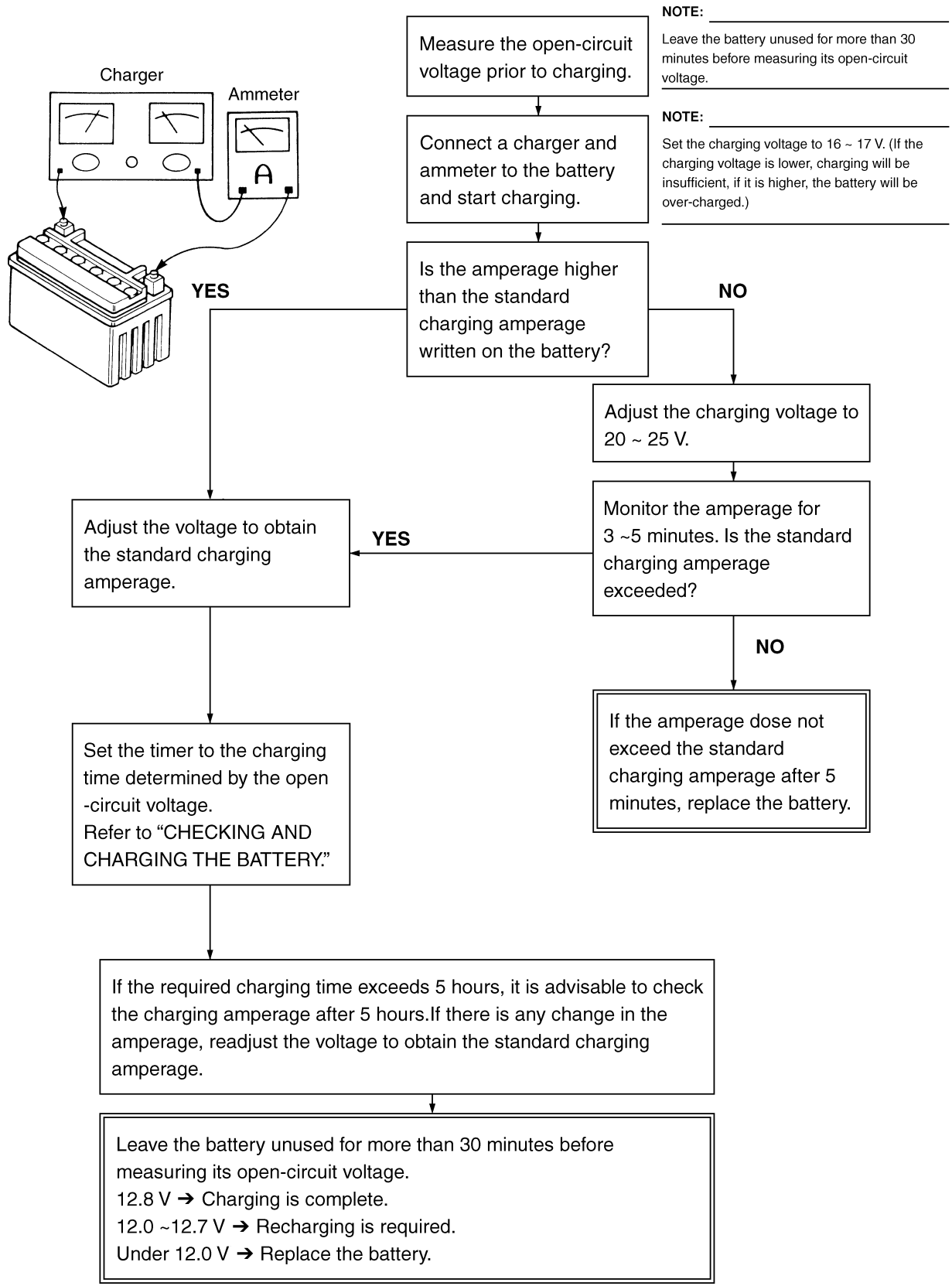

## Charging method using a constant voltage charger

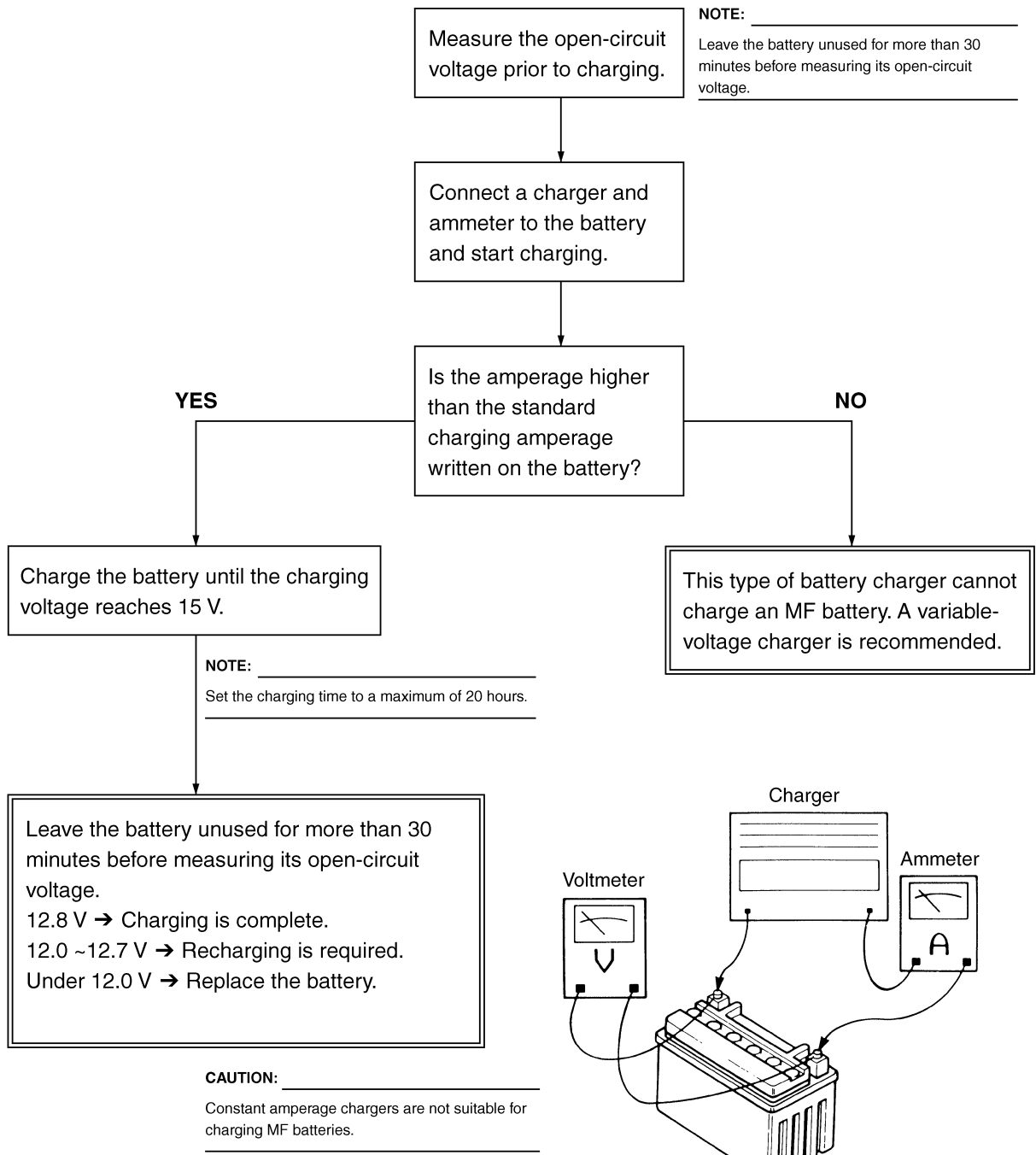

5. Check:

- Battery terminals  
Dirty → Clean with a wire brush.  
Poor connection → Correct.

**NOTE:** \_\_\_\_\_

After cleaning the terminals, apply a light coat of grease.

---

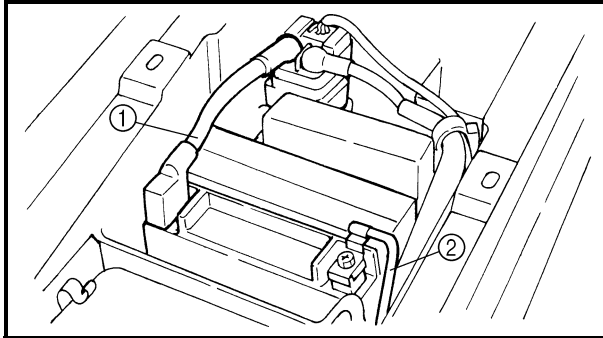

6. Install:

- Battery

7. Connect:

- Battery leads

**CAUTION:** \_\_\_\_\_

First, connect the positive lead ①, then connect the negative lead ②.

---

8. Install:

- Battery holding bracket

- Seat

Refer to "SEAT, FENDERS AND FUEL TANK".

## CHECKING THE FUSE

**CAUTION:** \_\_\_\_\_

Always turn off the main switch when checking or replacing a fuse. Otherwise, a short circuit may occur.

---

1. Remove:

- Seat

Refer to "SEAT, FENDERS AND FUEL TANK".

2. Check:

- Fuse

\*\*\*\*\*

**Checking steps:**

- Connect the pocket tester to the fuse and check it for continuity.

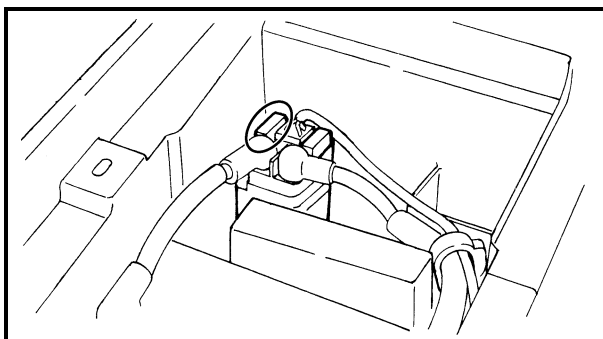



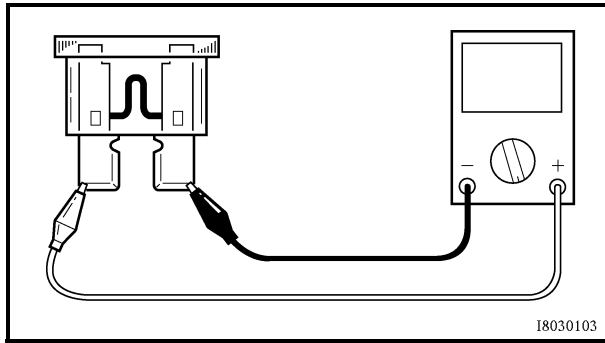

**NOTE:** \_\_\_\_\_  
Set the tester to the “ $\Omega \times 1$ ” position.



**Pocket tester:**  
**P/N. YU-03112, 90890-03112**

- If the tester indicates 0, replace the fuse.

\*\*\*\*\*

3. Replace:

- Blown fuse

\*\*\*\*\*

**Replacement steps:**

- Turn off the ignition.
- Install a new fuse of the proper amperage.
- Turn on switches to verify operation of the related electrical devices.
- If the fuse immediately blows again, check the electrical circuit.

\*\*\*\*\*

Description	Current rating	Quantity
Main	20 A	1
Reserve	20 A	1

**⚠ WARNING** \_\_\_\_\_

Never use a fuse with a rating other than that specified. Never use other materials in place of a fuse. An improper fuse may cause extensive damage to the electrical system, a malfunction of the lighting and ignition systems and could possibly cause a fire.

4. Install:

- Seat  
Refer to “SEAT, FENDERS AND FUEL TANK”.

# ADJUSTING THE HEADLIGHT BEAM/ REPLACING THE HEADLIGHT BULB

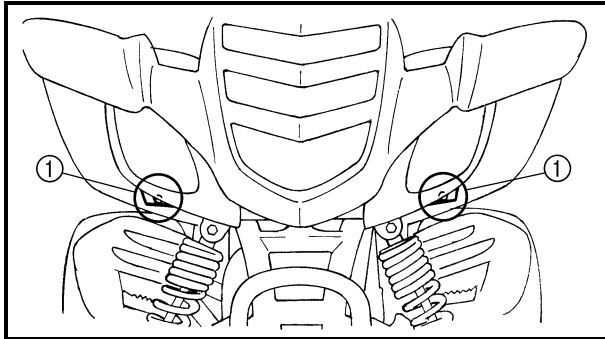

## ADJUSTING THE HEADLIGHT BEAM

1. Adjust:

- Headlight beam (vertically)

\*\*\*\*\*

### Adjustment steps:

- Loosen the screw ①.
- Slide the headlight lens unit under.

Slide forward	Headlight beam raises.
Slide backward	Headlight beam lowers.

- Tighten the screw ①.

\*\*\*\*\*

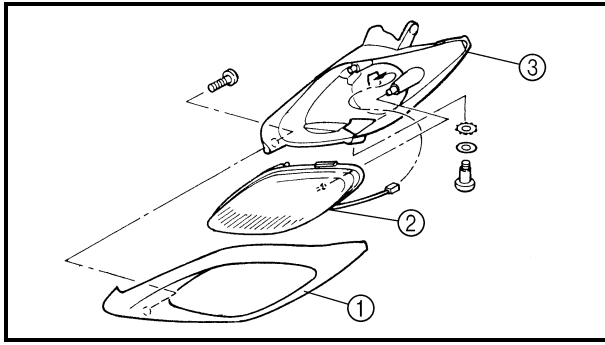

## REPLACING THE HEADLIGHT BULB

1. Remove:

- Headlight  
Refer to "SEAT, FENDERS AND FUEL TANK".

2. Remove:

- Cover ①
- Headlight unit ②
- Case ③

**NOTE:** \_\_\_\_\_  
Pull outward on the rear of the headlight unit ②, and then pull out ward on the front.

## REPLACING THE HEADLIGHT BULB

CHK  
ADJ

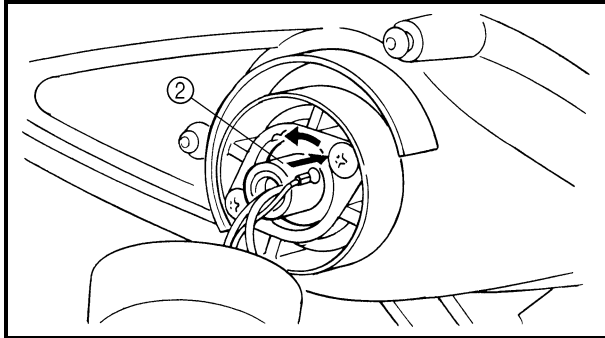
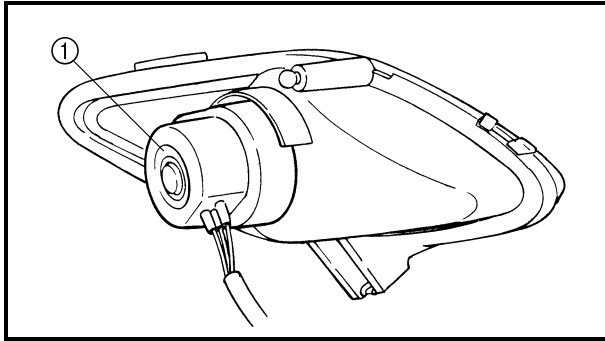

3.Remove:

- Cover ①
- Bulb holder ②
- Bulb

**NOTE:** \_\_\_\_\_

Turn the bulb holder counterclockwise and remove the defective bulb.

### **⚠ WARNING** \_\_\_\_\_

Keep flammable products and your hands away from the bulb while it is on, since it will be hot. Do not touch the bulb until it cools down.

4.Install:

- Bulb **New**

Secure the new bulb with the headlight unit.

### **CAUTION:** \_\_\_\_\_

Avoid touching the glass part of the bulb. Keep it free from oil; otherwise, the transparency of the glass, life of the bulb, and luminous flux will be adversely affected. If oil gets on the bulb, thoroughly clean it with a cloth moistened with alcohol or lacquer thinner.

5.Install:

- Bulb holder
- Cover
- Cover

6.Install:

- Headlight

Refer to "SEAT, FENDERS AND FUEL TANK".



CHASSIS

FRONT WHEELS

FRONT WHEELS

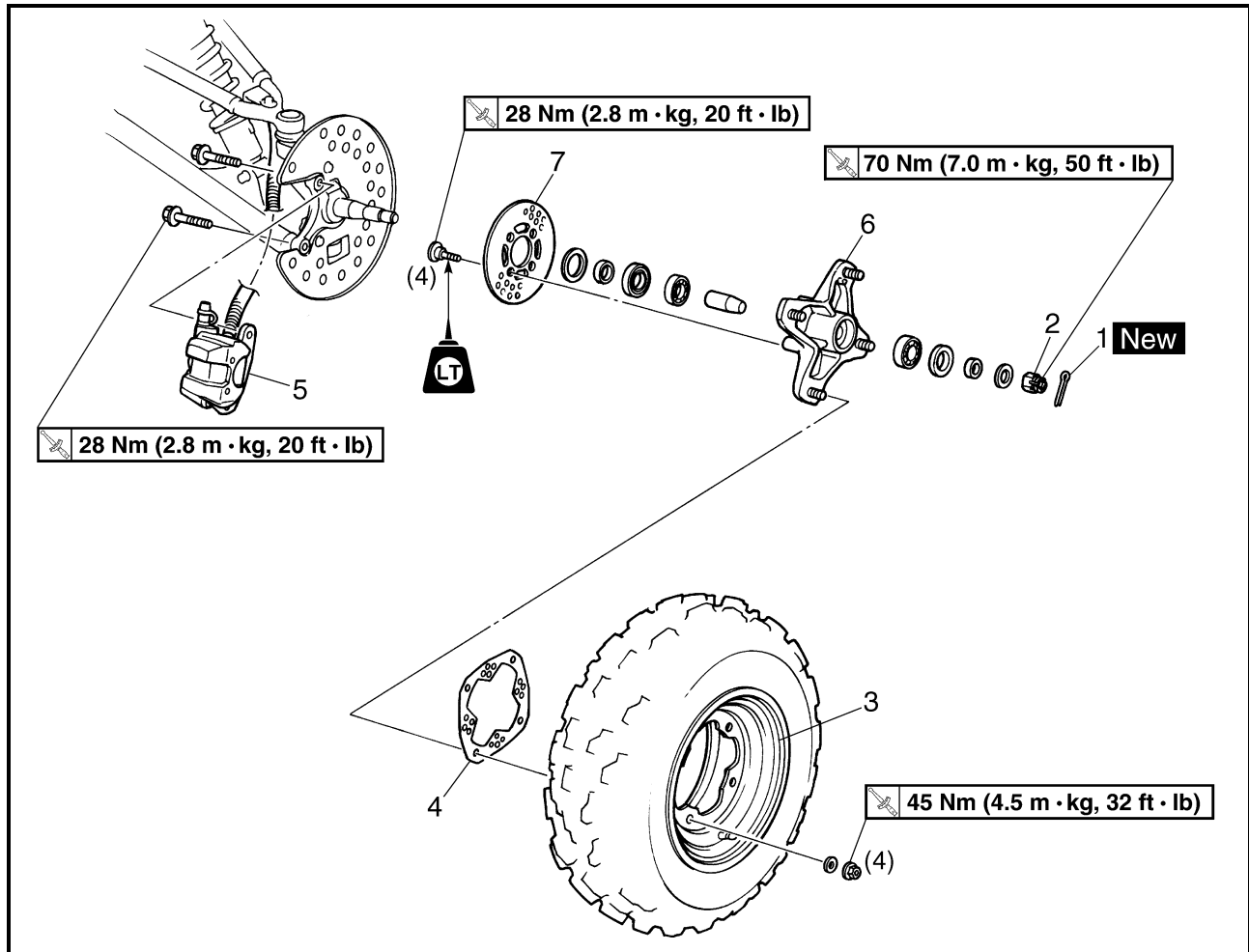

Order	Job name/Part name	Q'ty	Remarks
	<b>Removing the front wheel</b>		Remove the parts in the order below. Place the machine on a level surface.
			<b>⚠ WARNING</b> _____ <b>Securely support the machine so there is no danger of it falling over.</b>
1	Cotter pin	1	Refer to "INSTALLING THE WHEEL HUB". Refer to "INSTALLING THE WHEEL".
2	Axle nut	1	
3	Front wheel	1	
4	Brake disc guard (outer)	1	
5	Brake caliper assembly	1	
			<b>NOTE:</b> _____ Do not apply the brake lever after the brake calipers have been removed, otherwise the brake pads will be forced shut.

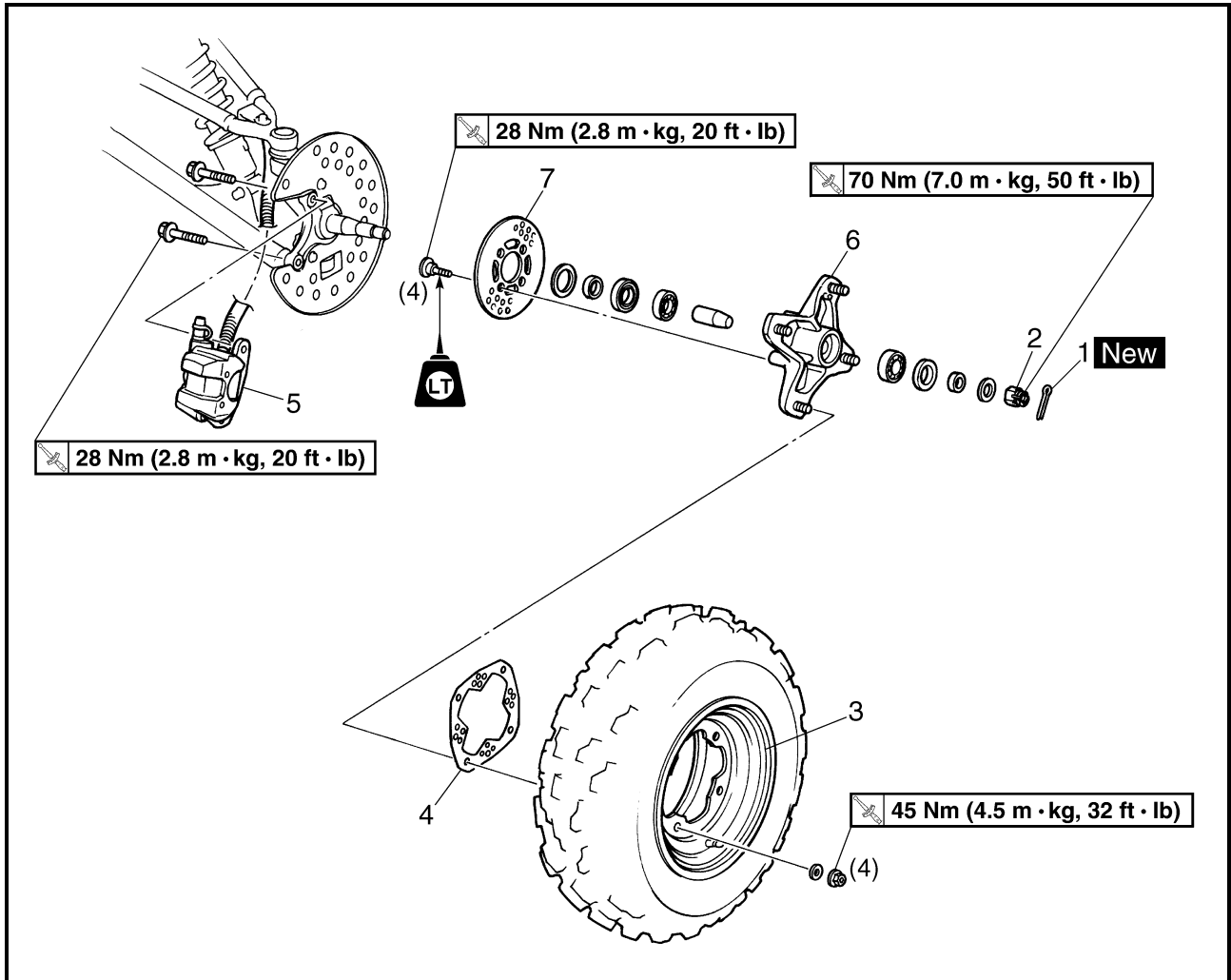

Order	Job name/Part name	Q'ty	Remarks
6	Wheel hub	1	For installation, reverse the removal procedure.
7	Brake disc	1	

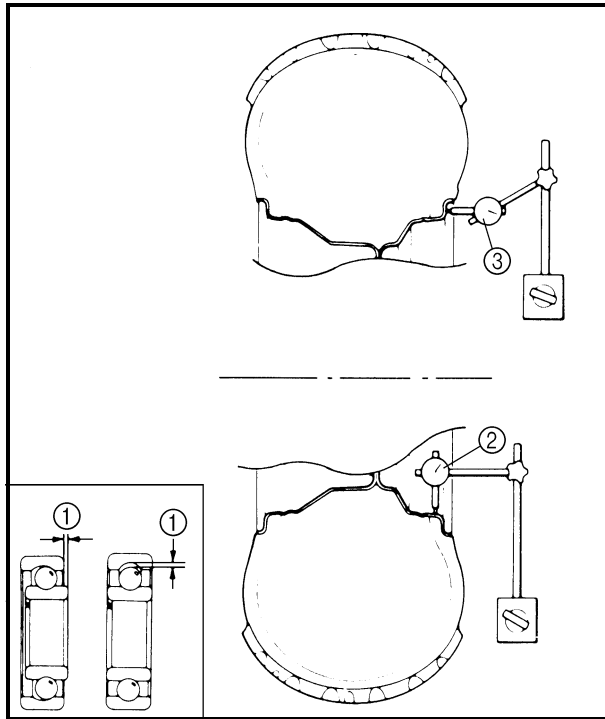

### CHECKING THE WHEEL

1. Check:
  - Wheel
2. Measure:
  - Wheel runout
    - Over the specified limit → Replace the wheel or check the wheel bearing play ①.



**Wheel runout limit:**  
 Radial ②: 2.0 mm (0.08 in)  
 Lateral ③: 2.0 mm (0.08 in)

3. Check:
  - Wheel balance
    - Out of balance → Adjust.

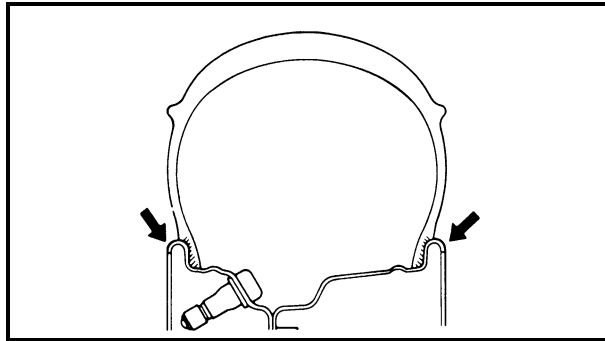

### ⚠ WARNING

After replacing the tire, ride conservatively to allow the tire to be properly seated in the rim. Failure to do so may cause an accident resulting in machine damage and possible operator injury.

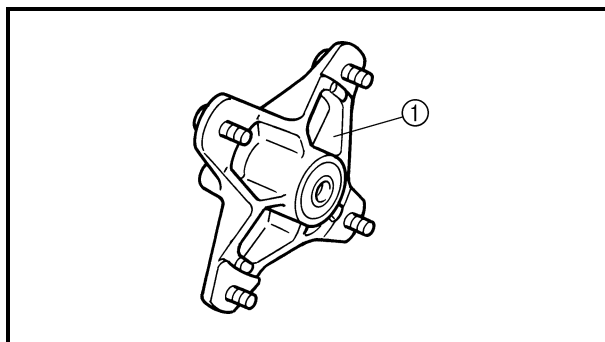

### CHECKING THE WHEEL HUB

1. Check:
  - Wheel hub ①
    - Cracks/damage → Replace.

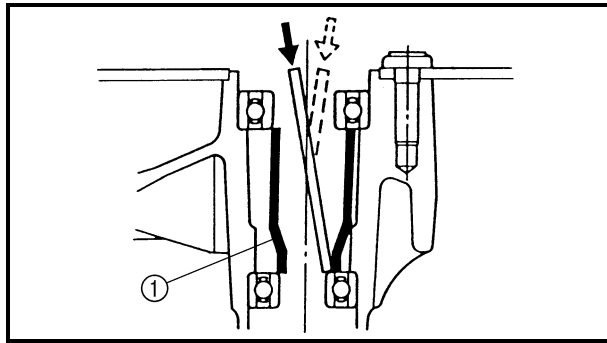

2. Check:

- Wheel bearings  
Wheel hub play/wheel turns roughly → Replace.

\*\*\*\*\*

**Wheel bearing replacement steps:**

- Clean wheel hub exterior.
- Drive bearing out by pushing spacer aside and tapping around perimeter of bearing inner race. Use soft metal drift punch and hammer. The spacer ① “floats” between bearings. Remove both bearings as described.

**⚠ WARNING**

**Eye protection is recommended when using striking tools.**

- To install the wheel bearings, reverse the above sequence. Use a socket that matches outside diameter of bearing outer race to drive in bearing.

**CAUTION:**

**Do not strike the center race or balls of the bearing. Contact should be made only with the outer race.**

\*\*\*\*\*

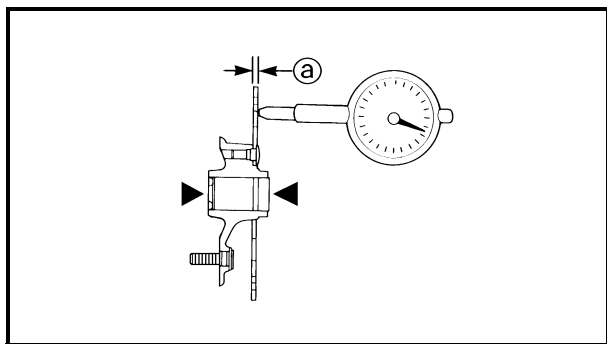

**CHECKING THE BRAKE DISC**

1. Check:

- Brake disc  
Galling/damage → Replace.

2. Measure:

- Brake disc deflection  
Out of specification → Replace.

	<b>Brake disc maximum deflection: 0.15 mm (0.006 in)</b>
--	--

- Brake disc thickness ②  
Out of specification → Replace.

	<b>Brake disc minimum thickness: 3 mm (0.12 in)</b>
--	---

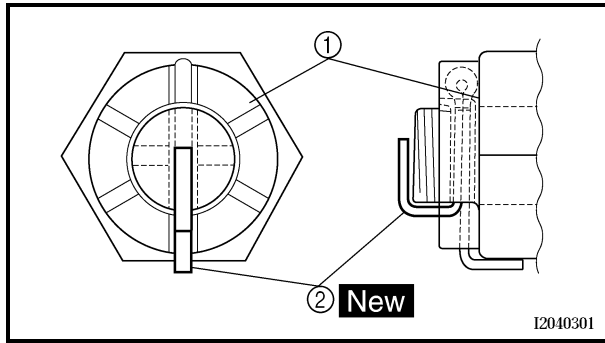

**INSTALLING WHEEL HUB**

1. Install:

- Axle nut ① 70 Nm (7.0 m • kg, 50 ft • lb)
- Cotter pin ② **New**

**NOTE:** \_\_\_\_\_

Do not loosen the axle nut after torquing it. If the axle nut groove is not aligned with the cotter pin hole, align the groove with the hole by tightening the axle nut.

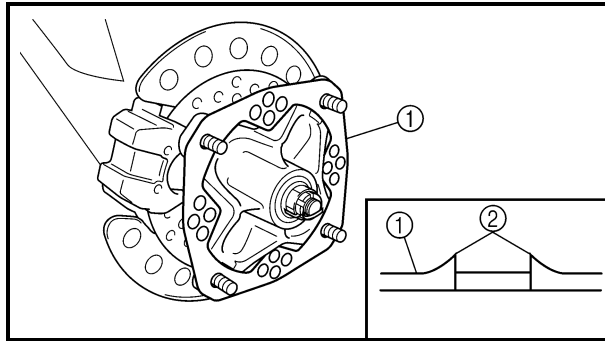

**INSTALLING THE WHEEL**

1. Install:

- Brake disc guard (outer) ①

**NOTE:** \_\_\_\_\_

Install the brake disc guard (outer) with punched burrs ② on the wheel hub side.

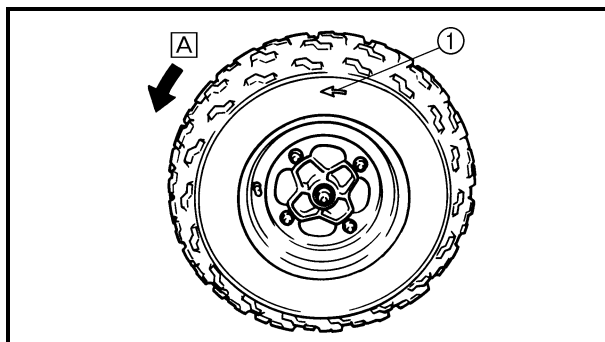

2. Install:

- Wheel

**NOTE:** \_\_\_\_\_

The arrow mark ① on the tire must point in the direction of rotation **A** of the wheel.





REAR WHEELS, WHEEL AXLE AND HUB

REAR WHEELS

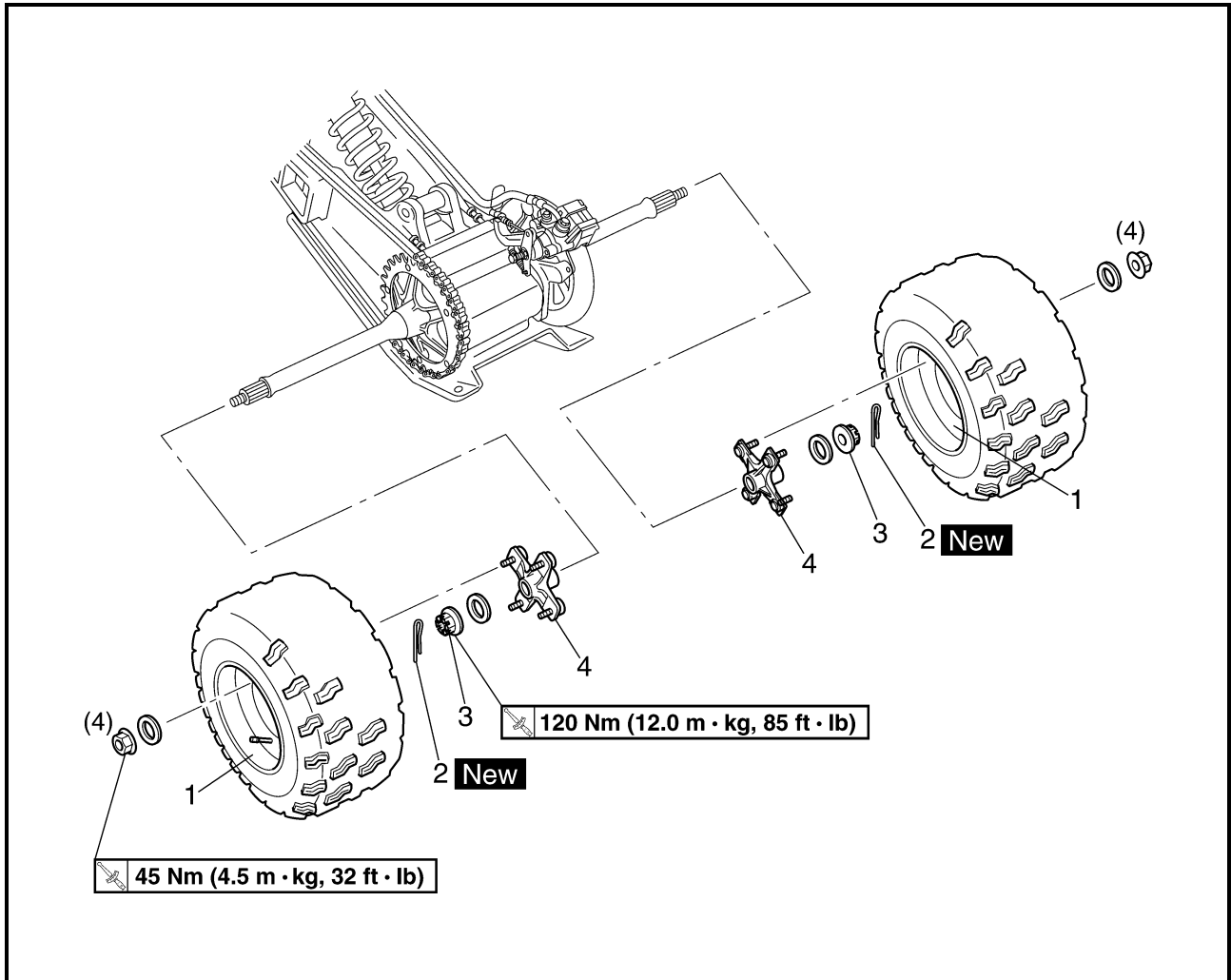

Order	Job name/Part name	Q'ty	Remarks
	<b>Removing the rear wheel</b>		Remove the parts in the order below. Place the machine on a level surface.
			<b>⚠ WARNING</b> <b>Securely support the machine so there is no danger of it falling over.</b>
1	Rear wheel	2	Refer to "INSTALLING THE WHEEL".
2	Cotter pin	2	Refer to "INSTALLING THE WHEEL HUB".
3	Axle nut	2	
4	Wheel hub	2	
			For installation, reverse the removal procedure.



WHEEL AXLE AND HUB

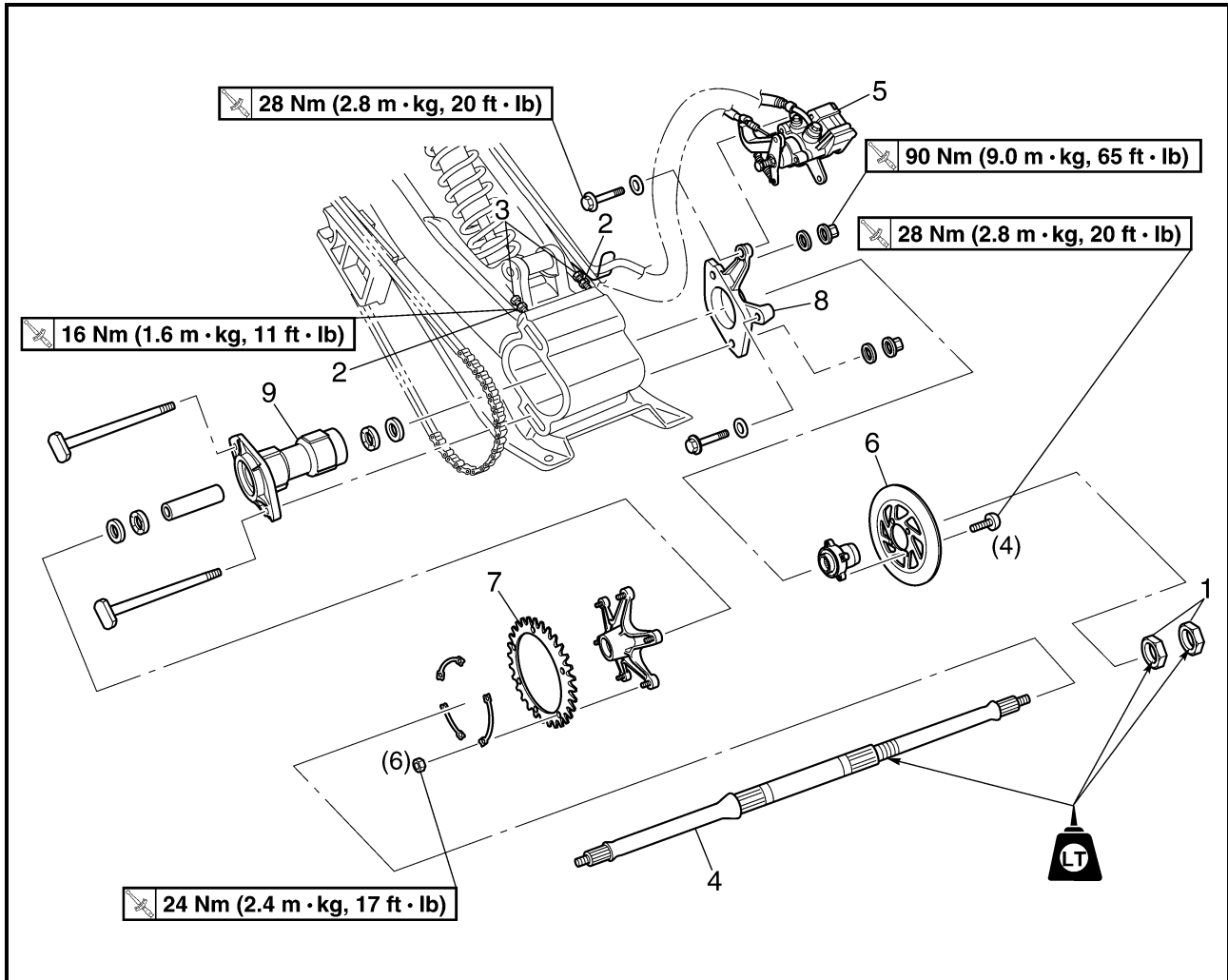

Order	Job name/Part name	Q'ty	Remarks
	<b>Removing the wheel axle and hub</b>		
1	Nut	2	Remove the parts in the order below.
2	Locknut	2	Refer to "INSTALLING THE NUTS (REAR AXLE)".
3	Adjusting bolt	2	Refer to "REMOVING THE REAR AXLE".
4	Rear axle	1	
5	Brake caliper	1	
			<b>NOTE:</b> _____ Do not apply the brake pedal and do not use the parking brake when the brake caliper is off of the brake disc as the brake pad will be force shut.

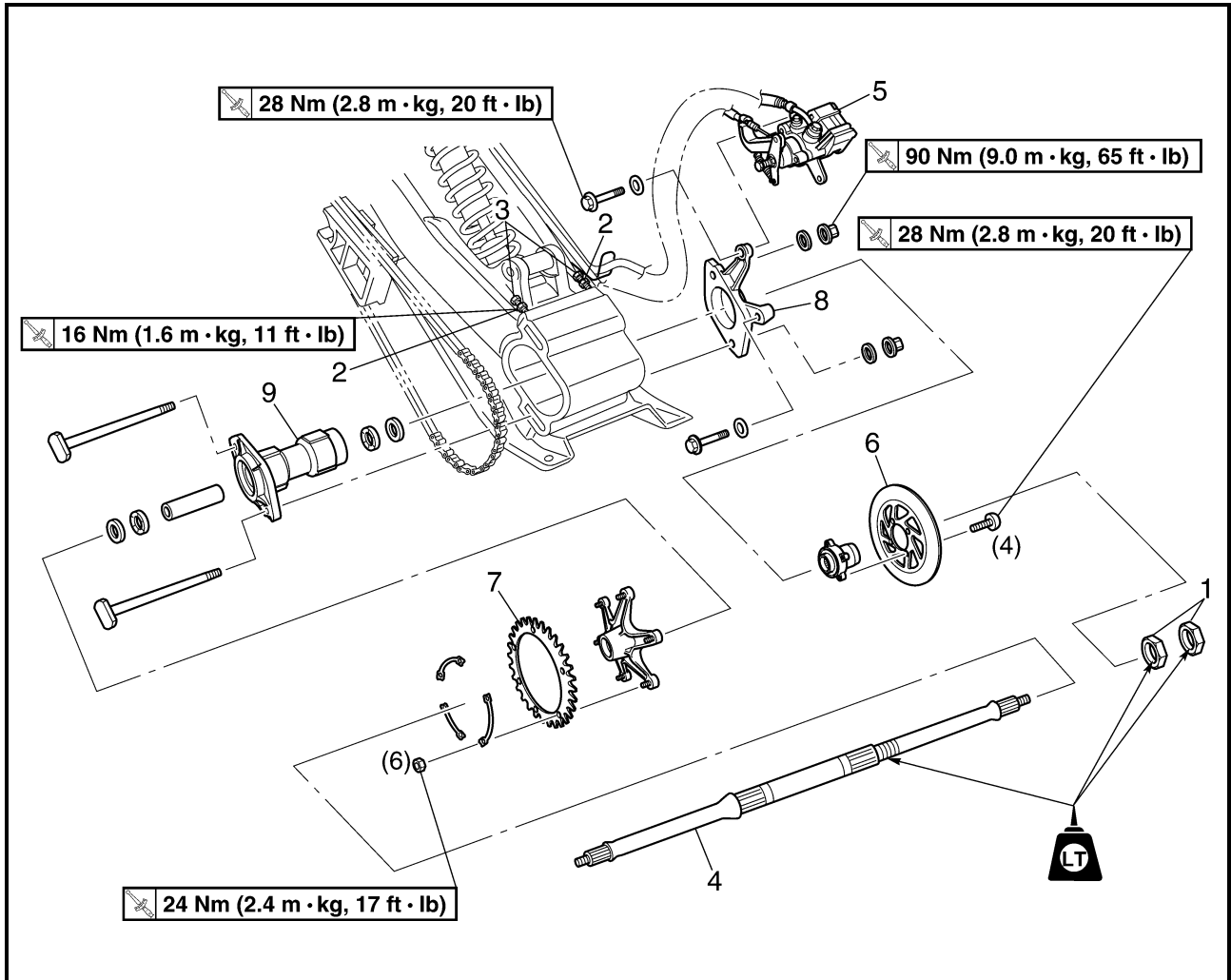

Order	Job name/Part name	Q'ty	Remarks
6	Brake disc	1	For installation, reverse the removal procedure.
7	Driven sprocket	1	
8	Brake caliper bracket	1	
9	Hub	1	

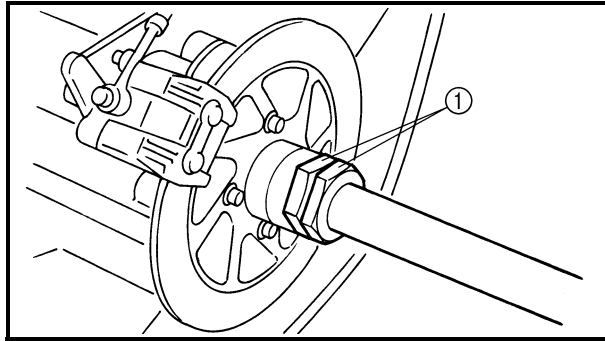

## REMOVING THE REAR AXLE

1. Place the machine on a level surface.

2. Loosen:

- Nuts (rear axle) ①

### NOTE:

- Apply the brake pedal so that the rear axle does not turn, when loosening the nuts.
- Use an axle nut wrench (50 mm) ②.

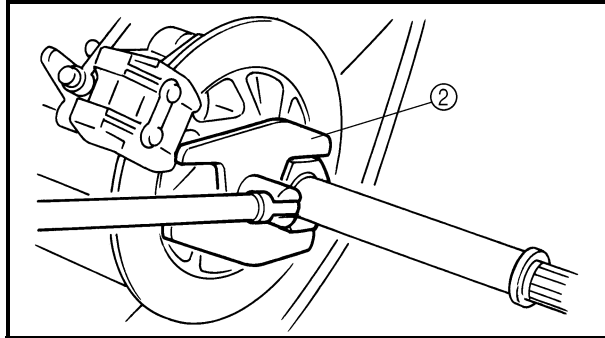

**Axle nut wrench (50 mm):**  
P/N. YM-37132, 90890-01419

3. Elevate the rear wheels by placing the suitable stand under the frame.

4. Remove:

- Rear wheels
- Wheel hubs
- Nuts (rear axle)

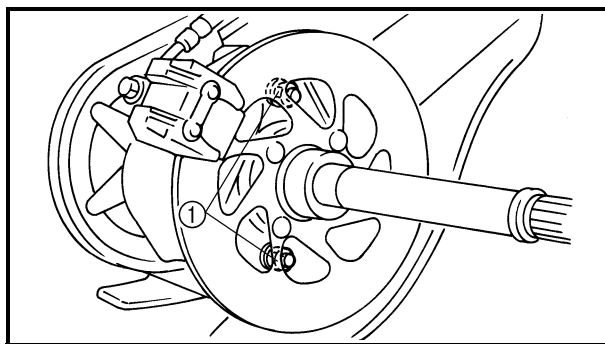

5. Loosen:

- Hub nuts ①

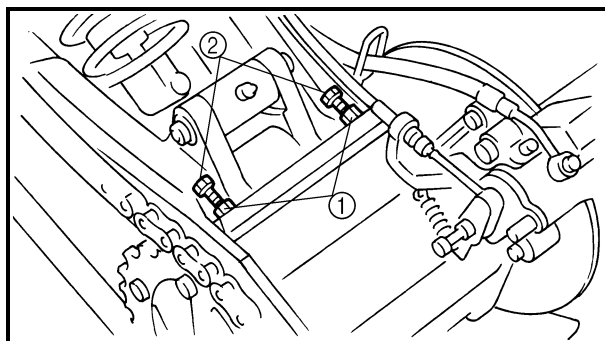

6. Loosen:

- Locknuts ①
- Adjusting bolts ②

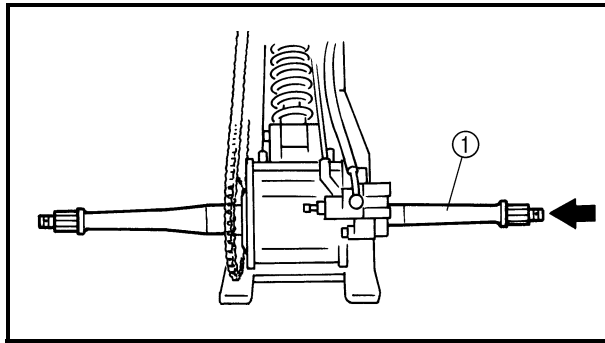

7.Remove:

- Rear axle ①

**CAUTION:**

- Never directly tap the axle end with a hammer, since this will result in damage to the axle thread and spline.
- Attach a suitable socket ② on the axle end and tap it with a soft hammer. Pull out the rear axle to the right.

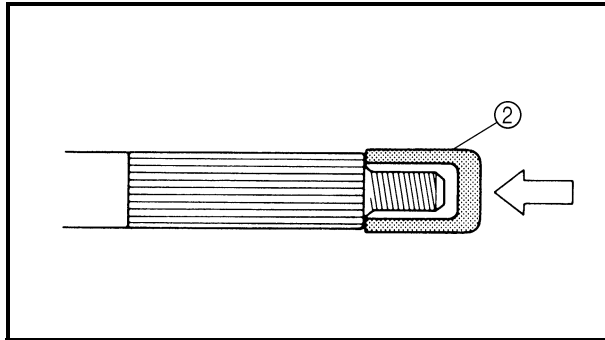

### CHECKING THE WHEEL

Refer to "FRONT WHEELS".

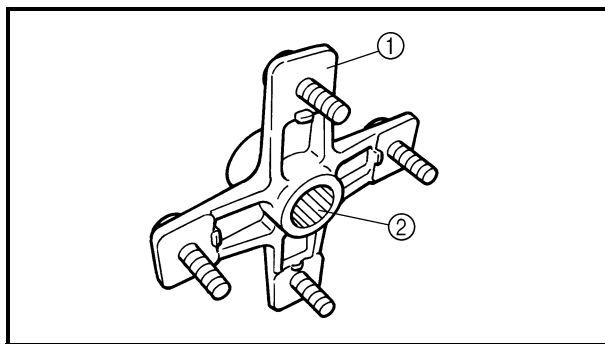

### CHECKING THE WHEEL HUB

1.Check:

- Wheel hub ①  
Cracks/damage → Replace.
- Splines (wheel hub) ②  
Wear/damage → Replace the wheel hub.

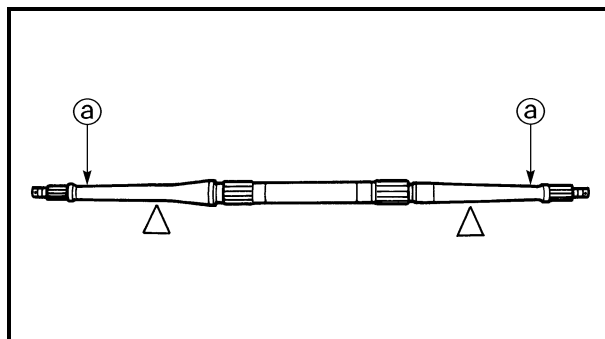

### CHECKING THE REAR AXLE

1.Check:

- Rear axle runout @  
Out of specification → Replace.

**⚠ WARNING**

Do not attempt to straighten a bent axle.



Rear axle runout limit:  
1.5 mm (0.06 in)

**CHECKING THE HUB**

1. Check:

- Hub bearings  
Refer to "FRONT WHEELS-WHEEL HUB INSPECTION".

**CHECKING THE BRAKE DISC**

Refer to "FRONT WHEELS".

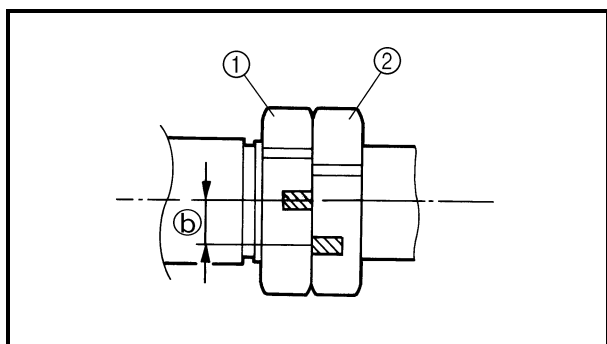
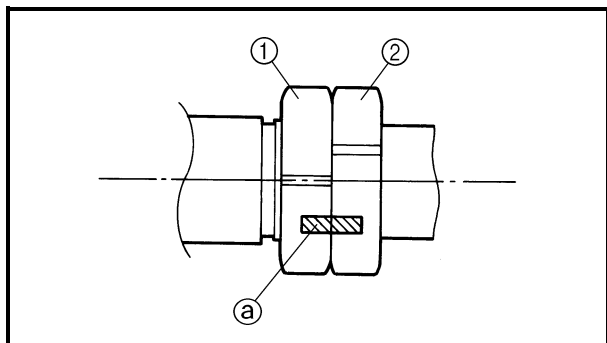
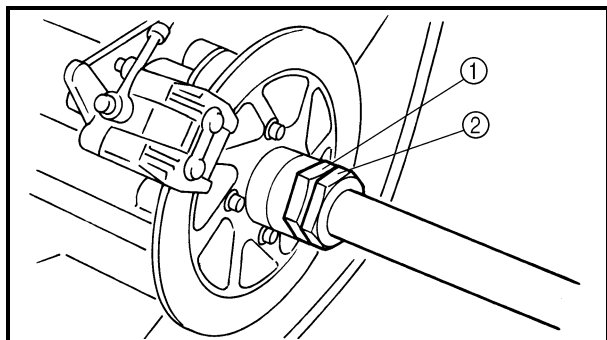

**INSTALLING THE NUTS (REAR AXLE)**

1. Tighten:

Nuts (rear axle) ①, ②

\*\*\*\*\*

**Nuts tightening steps:**

**NOTE:**

Before tightening the nuts, apply the LOC-TITE® to the thread portion of the rear axle.

- Finger tighten the inside nut ① while checking the ring gear engagement.
- Tighten the inside nut with rear axle nut wrench to specification while holding the rear axle.

	<b>Axle nut wrench (50 mm):</b> <b>P/N. YM-37132, 90890-01419</b>
---	--

	<b>Inside nut (first tightening):</b> <b>55 Nm (5.5 m • kg, 40 ft • lb)</b>
---	--

- Hold the inside nut ① and tighten the outside nut ② with rear axle nut wrench to specification.

	<b>Outside nut:</b> <b>190 Nm (19.0 m • kg, 140 ft • lb)</b>
---	---

- Draw the line ③ on inside and outside nut.
- Hold the outside nut ② and tighten back the inside nut ① with rear axle nut wrench to specification.

	<b>Inside nut (final tightening):</b> <b>240 Nm (24.0 m • kg, 170 ft • lb)</b>
---	---

- Measure the distance ④ between lines. If distance ④ is less than 15 mm (0.59 in), retighten back the inside nut.

\*\*\*\*\*



## INSTALLING THE WHEEL HUB

Refer to "FRONT WHEELS".

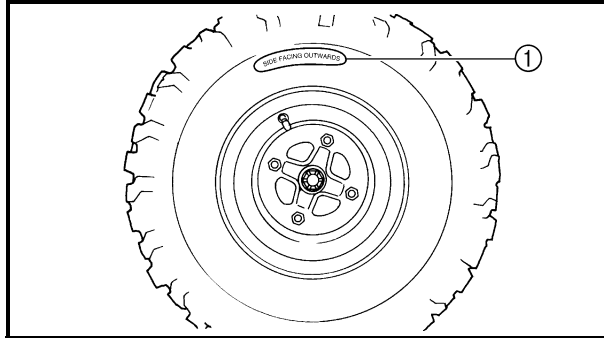

## INSTALLING THE WHEEL

1. Install:

- Wheel

### **NOTE:**

The wording on the tire "SIDE FACING OUTWARDS" ① must be facing outwards.

**FRONT AND REAR BRAKES**  
**FRONT BRAKE PADS**

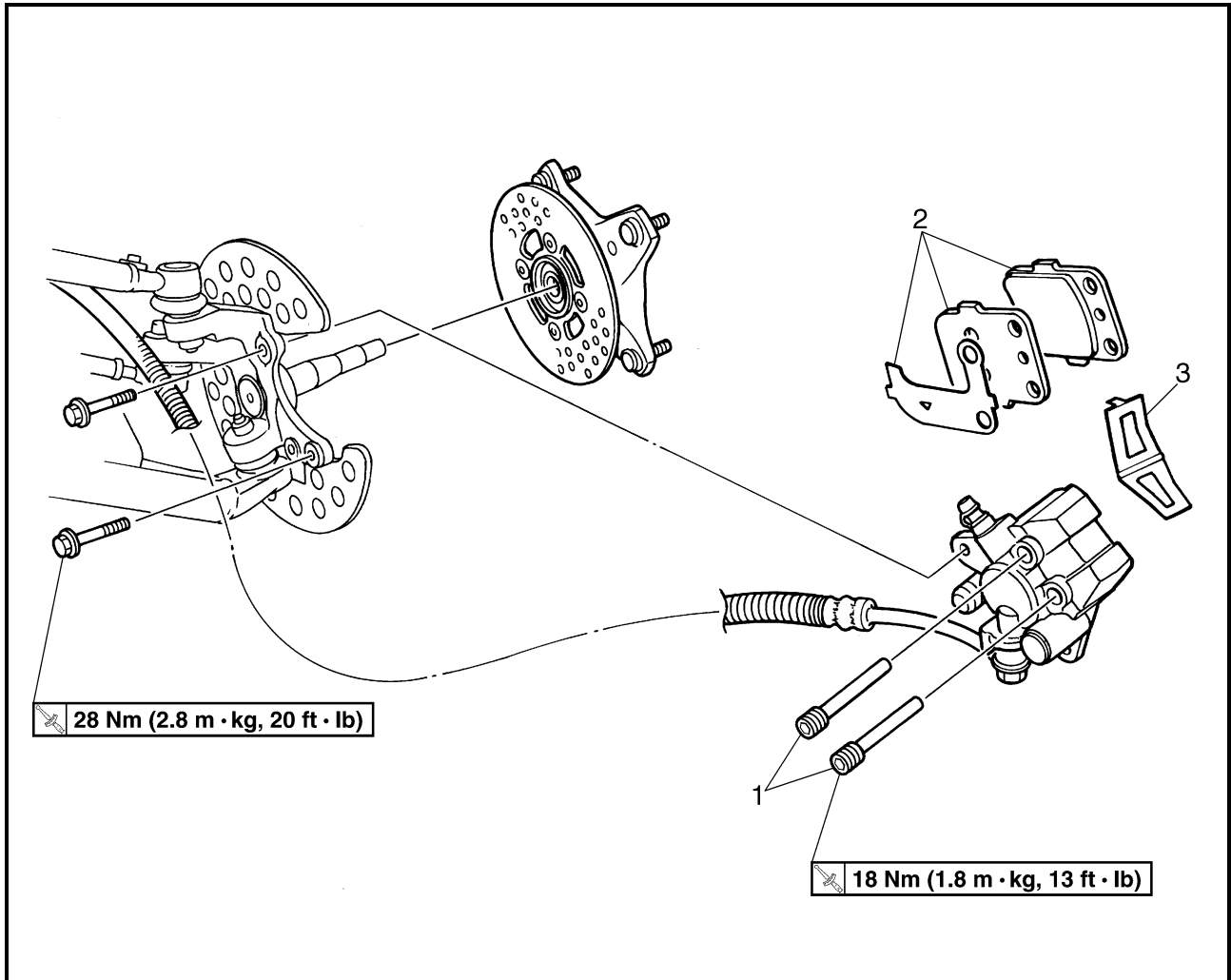

Order	Job name/Part name	Q'ty	Remarks
	<b>Removing the front brake pad</b>		
	Front wheel/wheel hub		Remove the parts in the order below. Refer to "FRONT WHEELS".
1	Brake pad holding bolt	2	Refer to "REPLACING THE FRONT BRAKE PAD".
2	Brake pad/pad shim	2/1	
3	Brake pad spring	1	
			For installation, reverse the removal procedure.





REAR BRAKE PADS

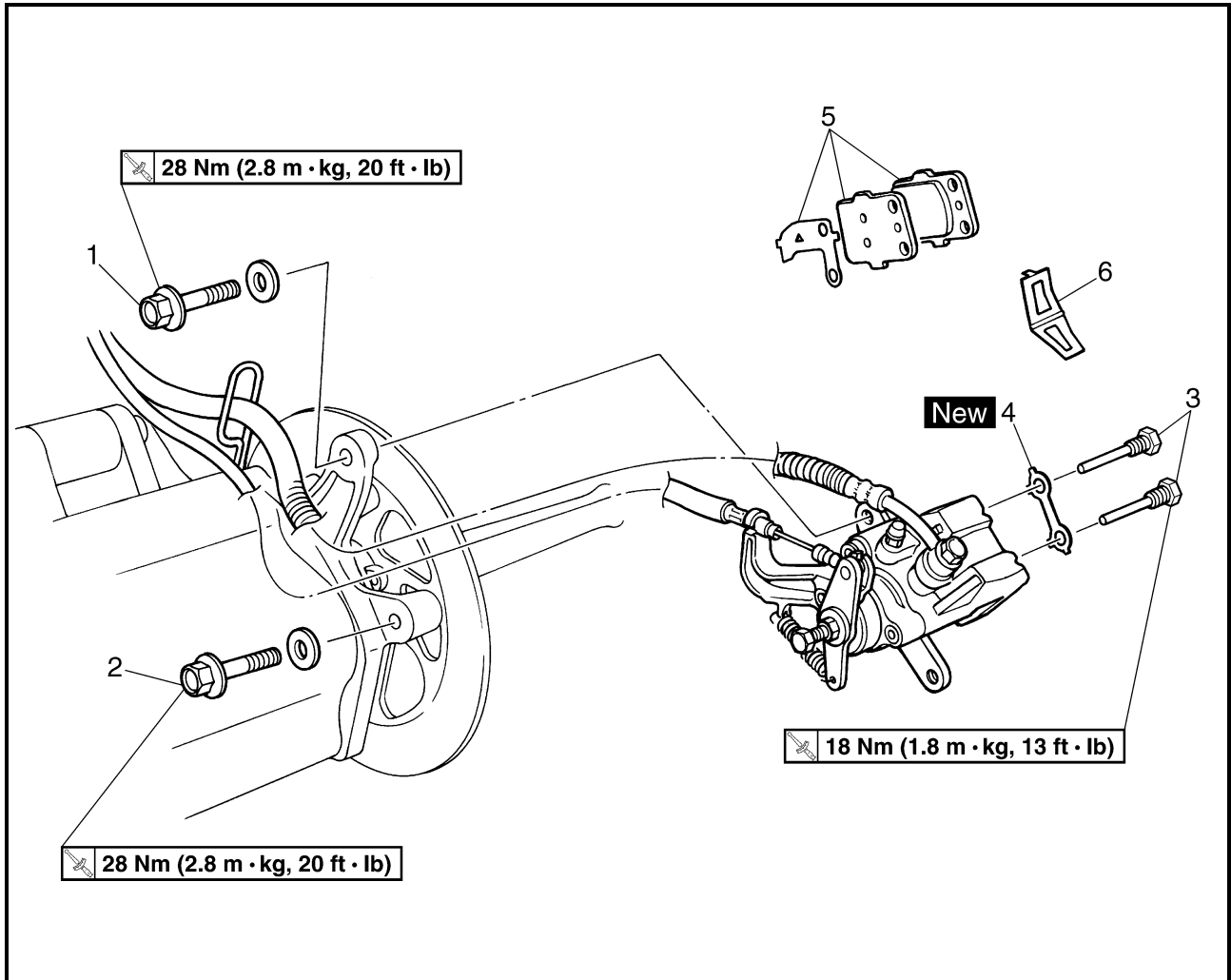

Order	Job name/Part name	Q'ty	Remarks
	<b>Removing rear brake pad</b>		Remove the parts in the order below.
1	Brake caliper mounting bolt	1	Refer to "REPLACING THE REAR BRAKE PAD".
2	Brake caliper mounting bolt	1	
3	Brake pad holding bolt	2	
4	Lock washer	1	
5	Brake pad/pad shim	2/1	
6	Brake pad spring	1	
			For installation, reverse the removal procedure.

**CAUTION:**

Disc brake components rarely require disassembly. DO NOT:

- disassemble components unless absolutely necessary;
- use solvents on internal brake components;
- use spent brake fluid for cleaning; (use only clean brake fluid)
- allow brake fluid to come in contact with the eyes, as this may cause eye injury;
- splash brake fluid onto painted surfaces or plastic parts, as this may cause damage;
- disconnect any hydraulic connection, as this would require the entire brake system to be disassembled, drained, cleaned, properly filled and bled after reassembly.

**REPLACING THE FRONT BRAKE PAD****NOTE:**

It is not necessary to disassemble the brake caliper and brake hose to replace the brake pads.

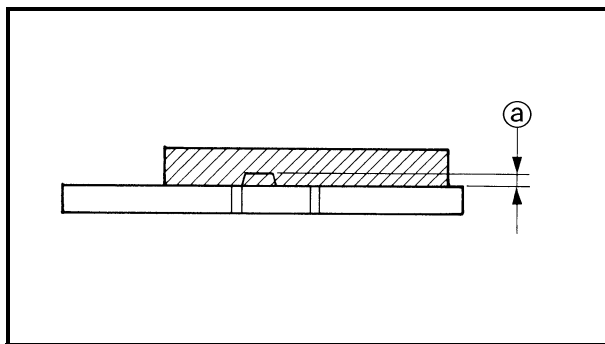
**1.Remove:**

- Brake pads
- Ⓐ Wear limit

**NOTE:**

Replace the brake pads as a set if either is found to be worn to the wear limit.

**2.Install:**

- Brake pads
- Brake pad spring

**NOTE:**

Always install new brake pads, brake pad shim and brake pad spring as a set.

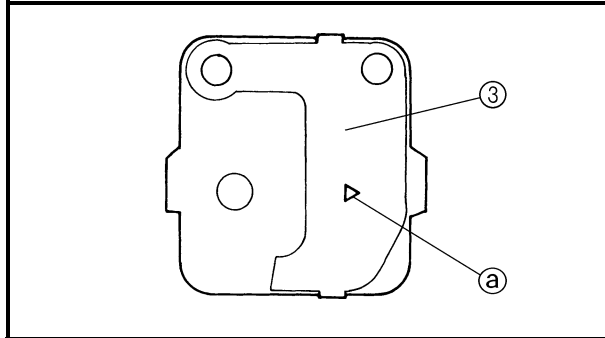
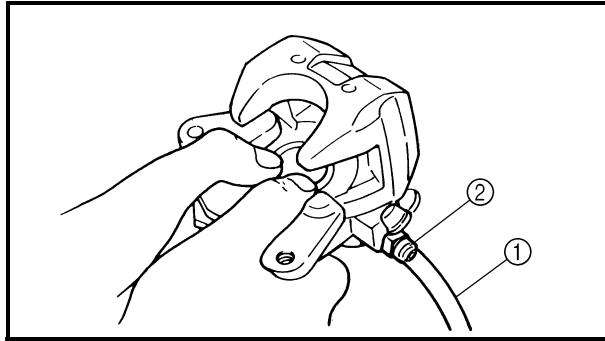

\*\*\*\*\*

**Installation steps:**

- Connect a suitable hose ① tightly to the brake caliper bleed screw ②. Put the other end of this hose into an open container.
- Loosen the brake caliper bleed screw and, using a finger, push the caliper piston into the brake caliper.
- Tighten the brake caliper bleed screw.



**Brake caliper bleed screw:**  
**6 Nm (0.6 m • kg, 4.3 ft • lb)**

- Install new brake pads, new pad shim ③ and a new brake pad spring.
- Install the holding bolts and brake caliper.

**NOTE:**

The arrow mark ① on the pad shim must point in the direction of the disc rotation.



**Brake pad holding bolt:**  
**18 Nm (1.8 m • kg, 13 ft • lb)**  
**Brake caliper mounting bolt:**  
**28 Nm (2.8 m • kg, 20 ft • lb)**

\*\*\*\*\*

**3.Check:**

- Brake fluid level  
 Refer to “CHECKING THE BRAKE FLUID LEVEL” in CHAPTER 3.

**4.Check:**

- Brake lever operation  
 Soft or spongy feeling → Bleed the front brake system.  
 Refer to “BLEEDING THE HYDRAULIC BRAKE SYSTEM” in CHAPTER 3.



**REPLACING THE REAR BRAKE PAD**

**NOTE:** \_\_\_\_\_

It is not necessary to disassemble the brake caliper and brake hose to replace the brake pads.

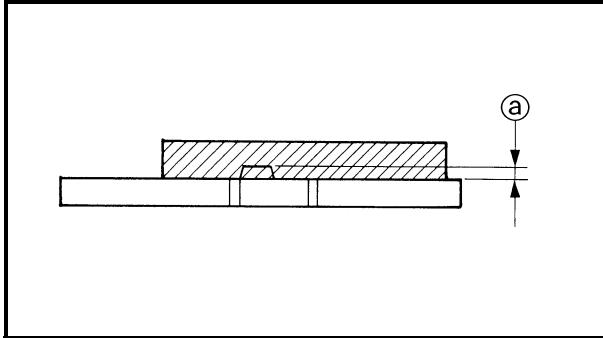

1.Remove:

- Brake pads
- ⓐ Wear limit

**NOTE:** \_\_\_\_\_

Replace the brake pads as a set if either is found to be worn to the wear limit.

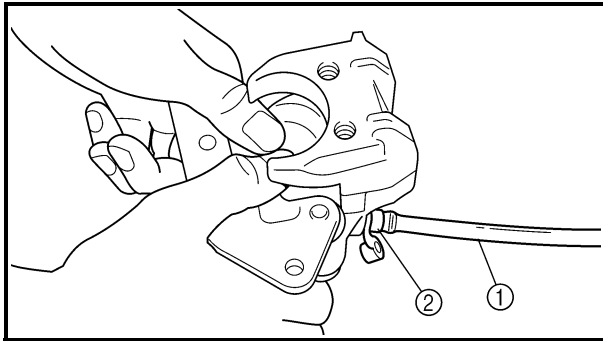

2.Install:

- Brake pads
- Brake pad spring

**NOTE:** \_\_\_\_\_

Always install new brake pads, brake pad shim and brake pad spring as a set.

\*\*\*\*\*

**Installation steps:**

- Connect a suitable hose ① tightly to the brake caliper bleed screw ②. Put the other end of this hose into an open container.
- Loosen the brake caliper bleed screw and, using a finger, push the caliper piston into the brake caliper.
- Tighten the brake caliper bleed screw.



**Brake caliper bleed screw:  
6 Nm (0.6 m • kg, 4.3 ft • lb)**

- Install new brake pads, new pad shim ③ and a new brake pad spring.
- Install a new lock washer, holding bolts and brake caliper.

**NOTE:** \_\_\_\_\_

The arrow mark ⓐ on the pad shim must point in the direction of the disc rotation.

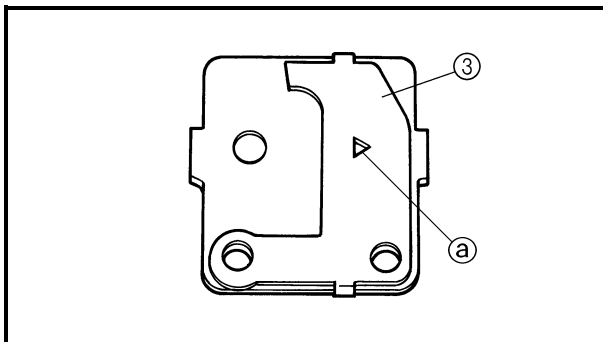



**Brake pad holding bolt:**  
**18 Nm (1.8 m • kg, 13 ft • lb)**  
**Brake caliper mounting bolt:**  
**28 Nm (2.8 m • kg, 20 ft • lb)**

- Bend the lock washer tabs along a flat side of the bolts.

\*\*\*\*\*

3.Check:

- Brake fluid level  
Refer to “CHECKING THE BRAKE FLUID LEVEL” in CHAPTER 3.

4.Check:

- Brake pedal operation  
Soft or spongy feeling → Bleed the rear brake system.  
Refer to “BLEEDING THE HYDRAULIC BRAKE SYSTEM” in CHAPTER 3.



FRONT BRAKE MASTER CYLINDER

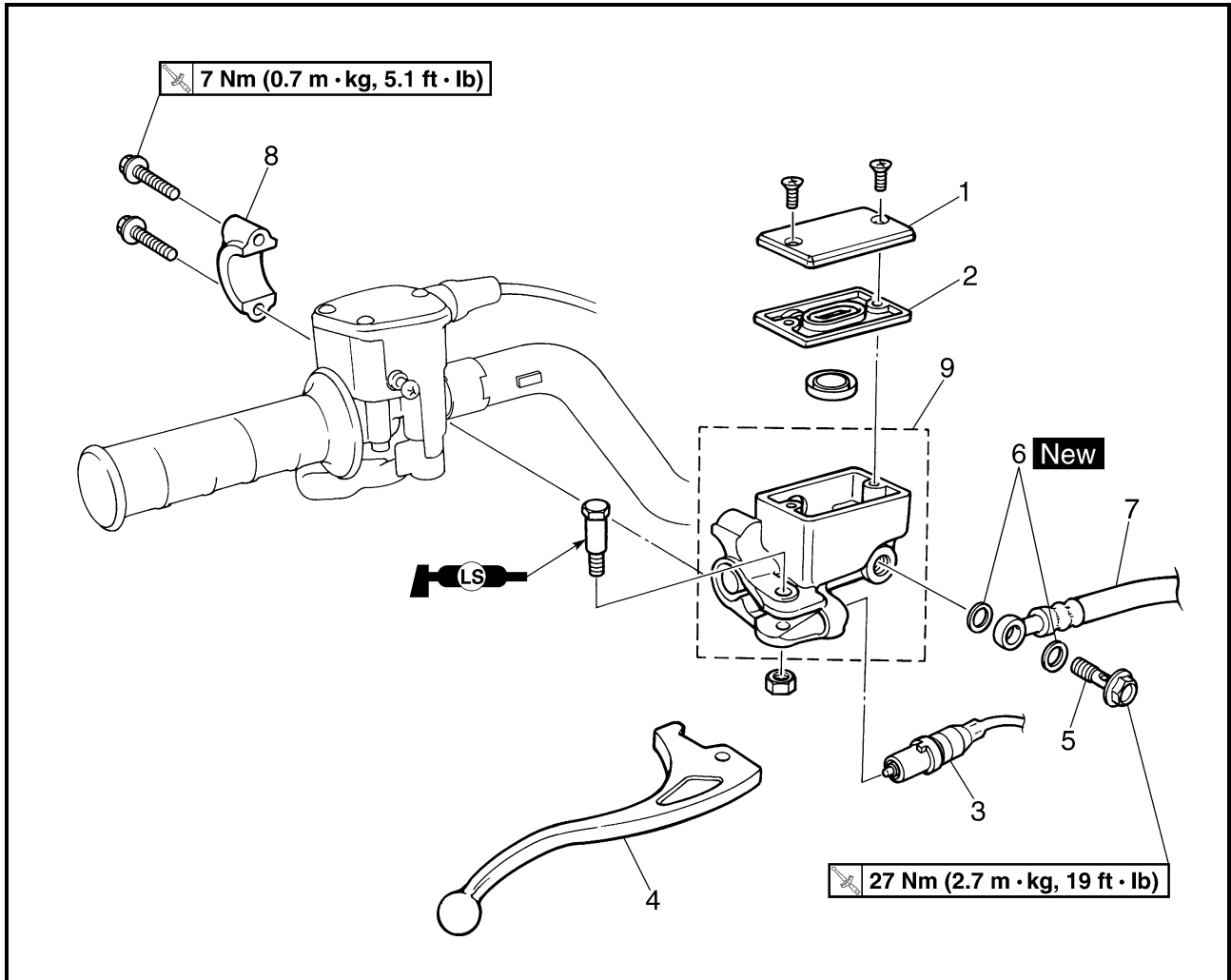

Order	Job name/Part name	Q'ty	Remarks
	<b>Removing front brake master cylinder</b>		Remove the parts in the order below.
	Brake fluid		Drain.
1	Brake fluid reservoir cap	1	
2	Brake fluid reservoir diaphragm	1	
3	Front brake switch	1	
4	Brake lever	1	
5	Union bolt	1	
6	Copper washer	2	
7	Brake hose	1	Refer to "INSTALLING THE FRONT BRAKE MASTER CYLINDER".
8	Brake master cylinder bracket	1	
9	Brake master cylinder	1	
			For installation, reverse the removal procedure.

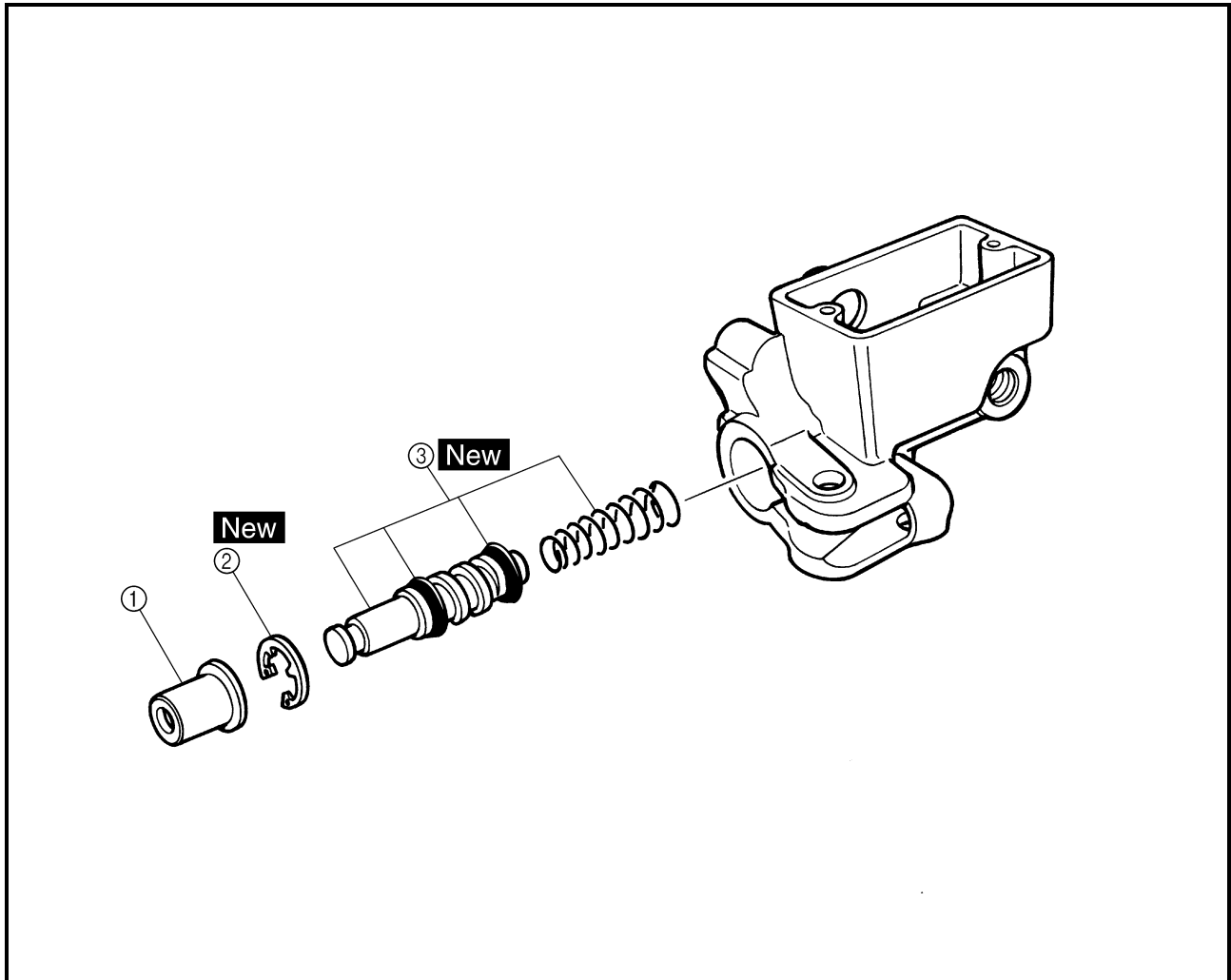

Order	Job name/Part name	Q'ty	Remarks
	<b>Disassembling the front brake master cylinder</b>		Remove the parts in the order below.
①	Dust boot	1	Refer to "ASSEMBLING THE FRONT AND REAR BRAKE MASTER CYLINDER". For assembly, reverse the disassembly procedure.
②	Circlip	1	
③	Brake master cylinder kit	1	



REAR BRAKE MASTER CYLINDER

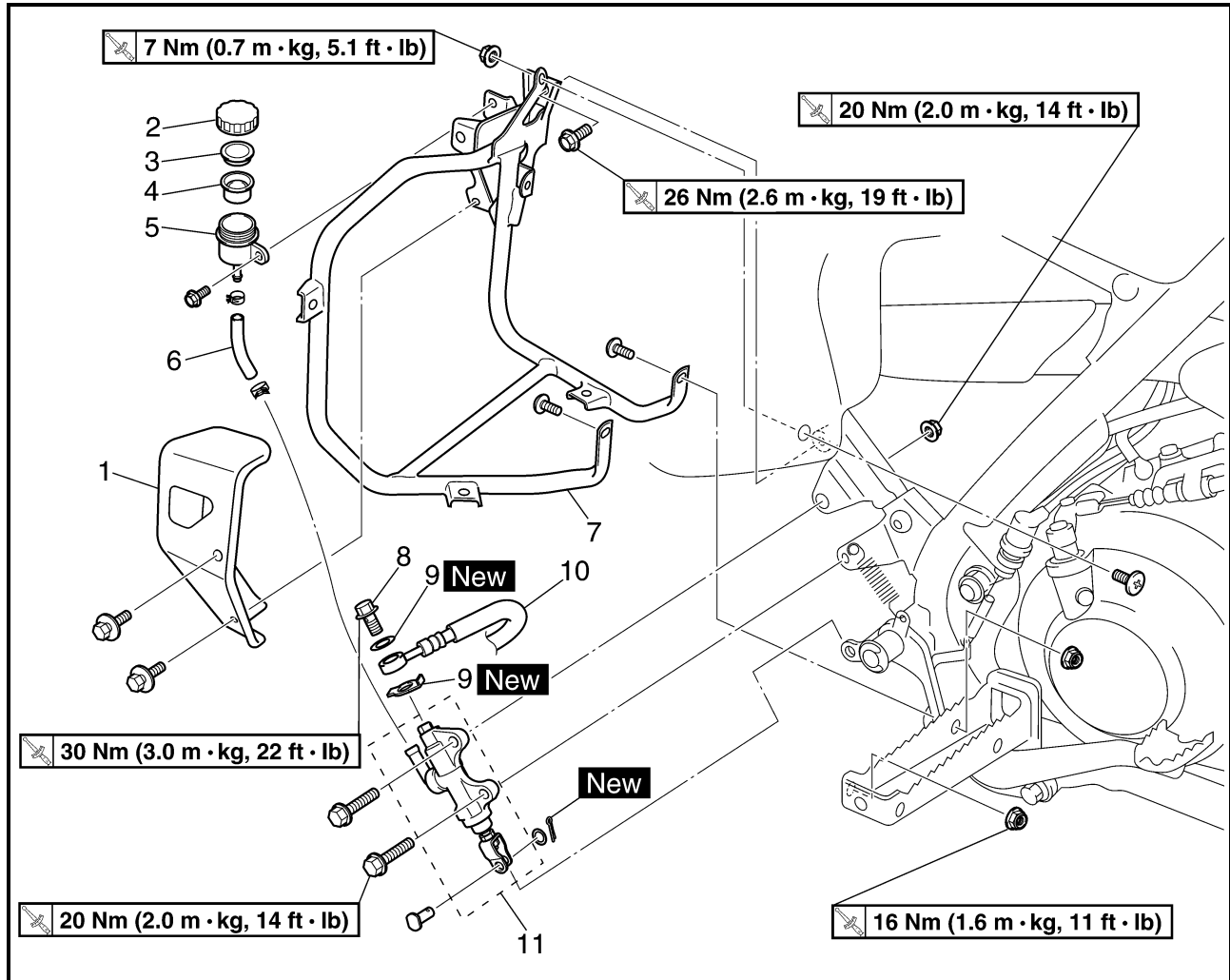

Order	Job name/Part name	Q'ty	Remarks
	<b>Removing the rear brake master cylinder</b>		Remove the parts in the order below.
	Right footrest guard		Refer to "SEAT, FENDERS AND FUEL TANK" in CHAPTER 3.
	Brake fluid		Drain.
1	Brake fluid reservoir cover	1	
2	Brake fluid reservoir cap	1	
3	Brake fluid reservoir diaphragm holder	1	
4	Brake fluid reservoir diaphragm	1	
5	Brake fluid reservoir	1	
6	Brake fluid reservoir hose	1	
7	Right footrest guard bracket	1	



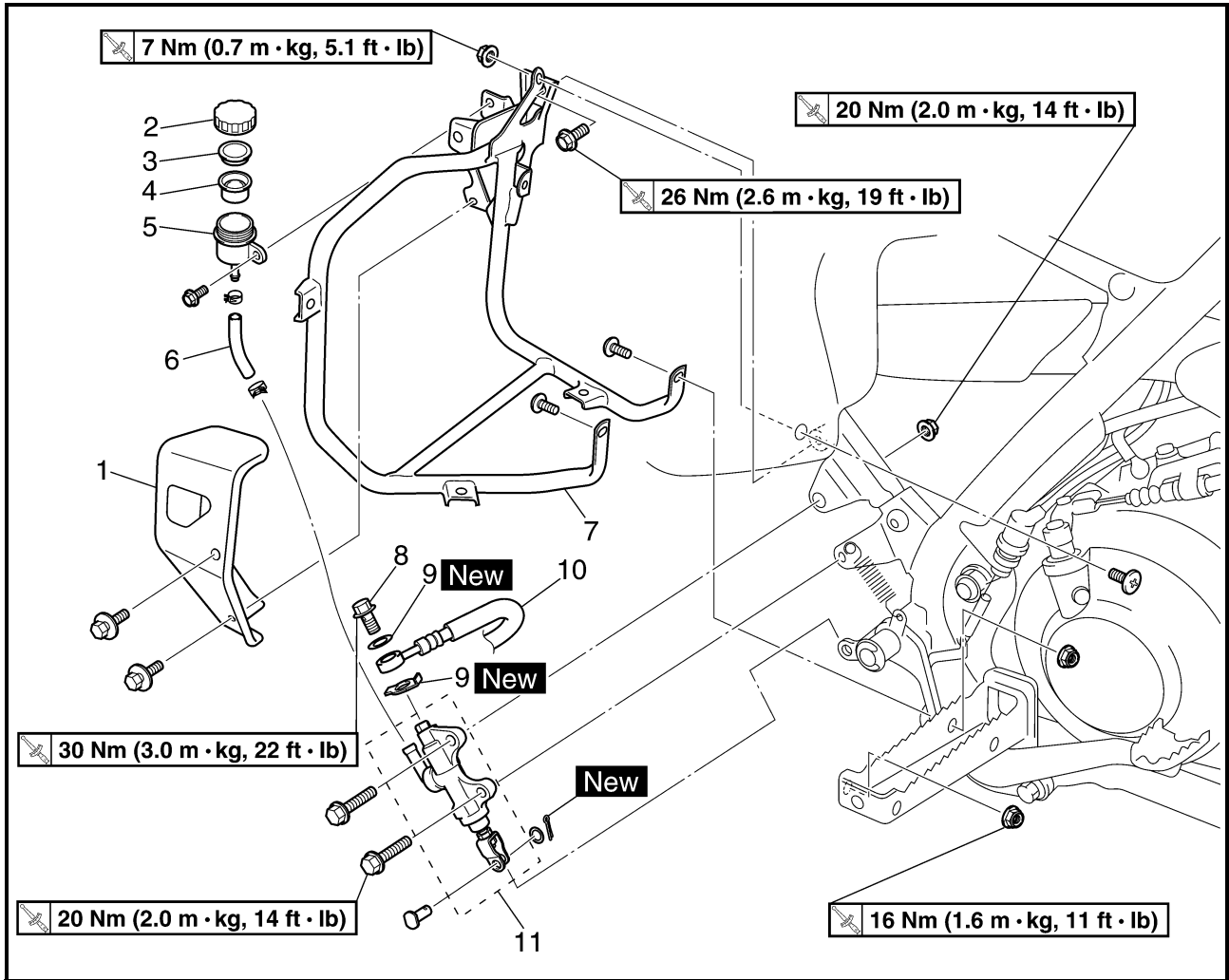

Order	Job name/Part name	Q'ty	Remarks
8	Union bolt	1	Refer to "INSTALLING THE REAR BRAKE MASTER CYLINDER".
9	Copper washer	2	
10	Brake hose	1	
11	Brake master cylinder	1	
			For installation, reverse the removal procedure.

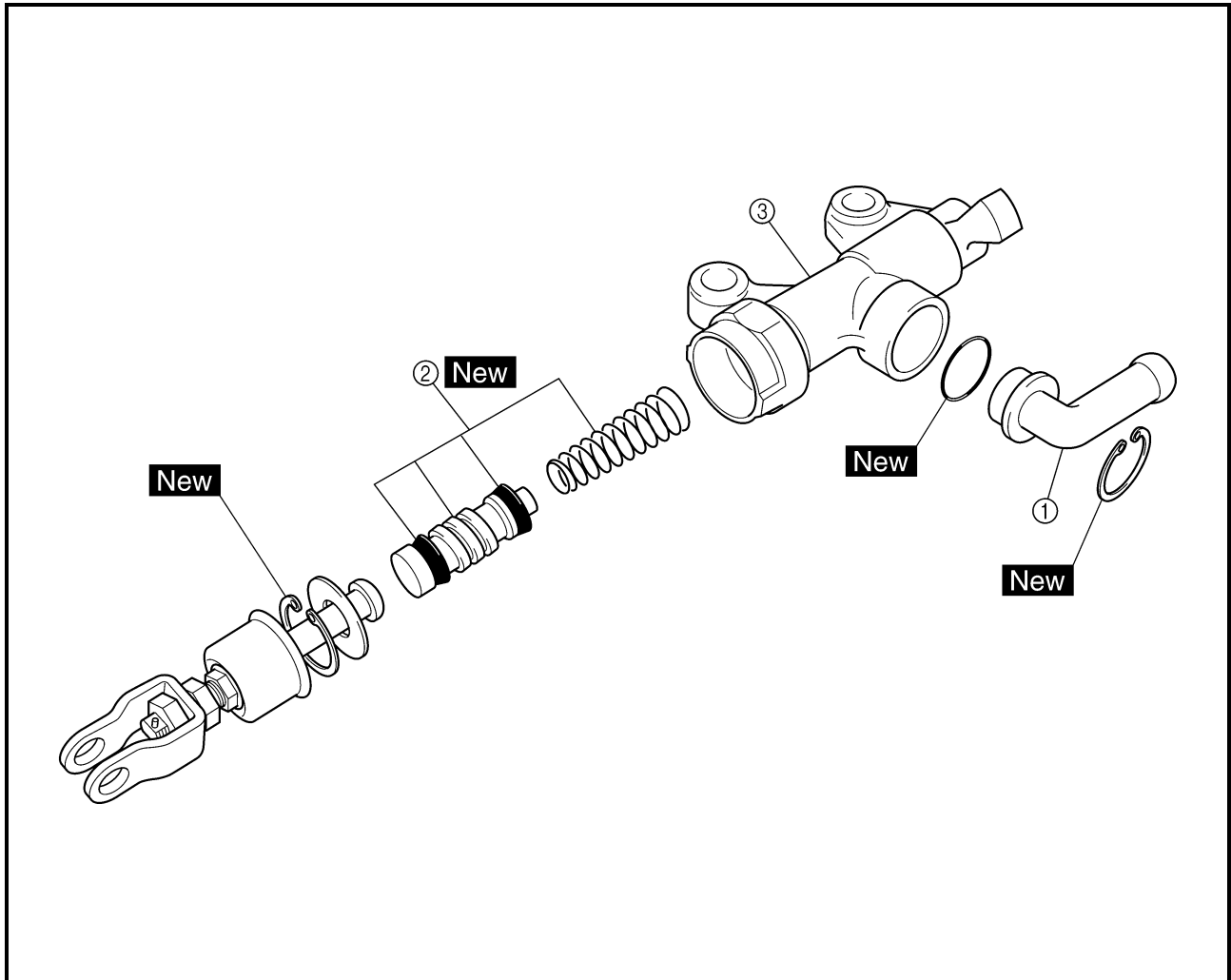

Order	Job name/Part name	Q'ty	Remarks
	<b>Disassembling the rear brake master cylinder</b>		Remove the parts in the order below.
①	Hose joint	1	Refer to "ASSEMBLING THE FRONT AND REAR BRAKE MASTER CYLINDER". For assembly, reverse the disassembly procedure.
②	Brake master cylinder kit	1	
③	Brake master cylinder	1	

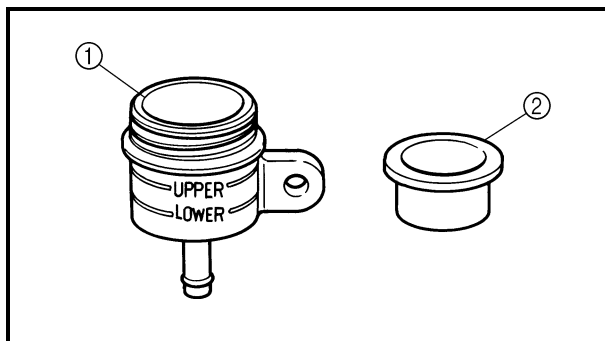
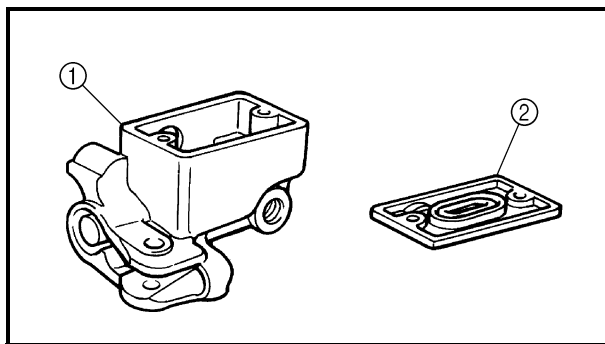
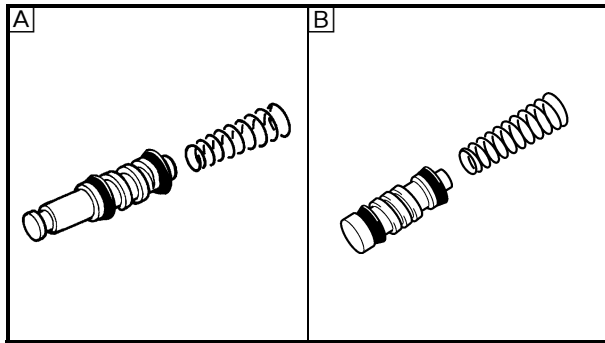
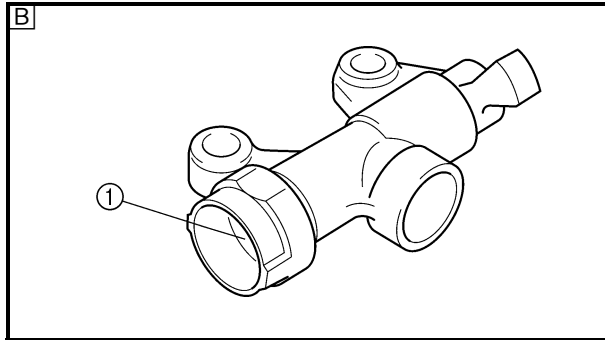
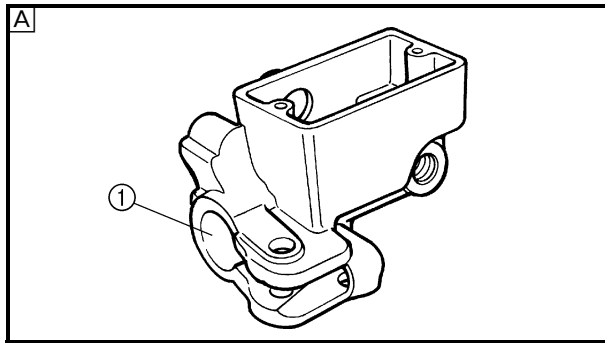

## CHECKING THE MASTER CYLINDER

1. Check:

- Brake master cylinder ①  
Wear/scratches → Replace the brake master cylinder assembly.
- Brake master cylinder body  
Cracks/damage → Replace.
- Brake fluid delivery passage (brake master cylinder body)  
Blockage → Blow out with compressed air.

Ⓐ Front

Ⓑ Rear

2. Check:

- Brake master cylinder kit  
Scratches/wear/damage → Replace as a set.

Ⓐ Front

Ⓑ Rear

3. Check:

- Front brake master cylinder reservoir ①
- Front brake master cylinder reservoir diaphragm ②  
Cracks/damage → Replace.

4. Check:

- Rear brake fluid reservoir ①
- Rear brake fluid reservoir diaphragm ②  
Cracks/damage → Replace.



EB702060

**ASSEMBLING THE FRONT AND REAR BRAKE MASTER CYLINDER**

**⚠ WARNING**

- All internal brake components should be cleaned and lubricated with new brake fluid only before installation.



**Recommended brake fluid:  
DOT 4**

- Whenever a master cylinder is disassembled, replace the piston seals and dust seals.

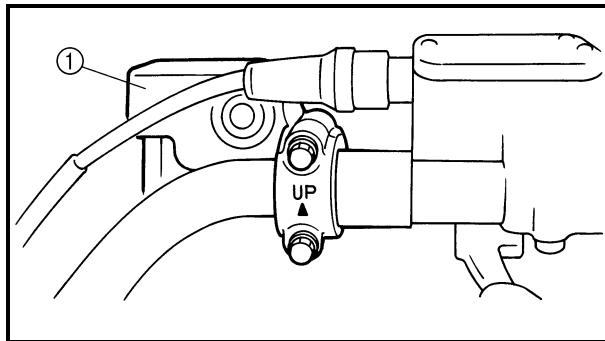

**INSTALLING THE FRONT BRAKE MASTER CYLINDER**

1. Install:

- Brake master cylinder ①

**7 Nm (0.7 m • kg, 5.1 ft • lb)**

**NOTE:**

The “UP” mark on the brake master cylinder bracket should face up.

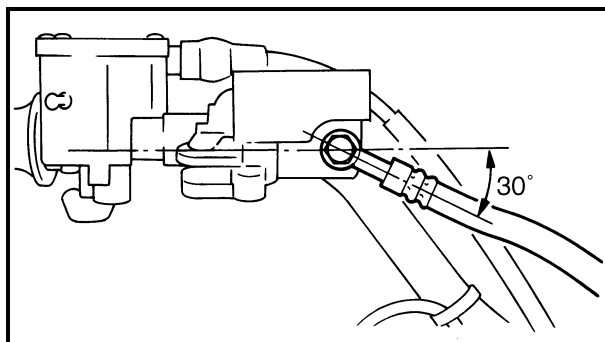

2. Install:

- Copper washers **New**
- Brake hose
- Union bolt

**27 Nm (2.7 m • kg, 19 ft • lb)**

**NOTE:**

- Tighten the union bolt while holding the brake hose as shown.
- Turn the handlebar to the left and to the right to check that the brake hose does not touch other parts (throttle cable, wire harness, leads, etc.). Correct if necessary.

**⚠ WARNING**

Proper brake hose routing is essential to insure safe machine operation. Refer to “CABLE ROUTING”.



## 3.Fill:

- Brake fluid reservoir



Recommended brake fluid:  
DOT 4

**CAUTION:**

Brake fluid may damage painted surfaces or plastic parts. Always clean up spilled brake fluid immediately.

**⚠ WARNING**

- Use only the designated quality brake fluid: Other brake fluids may deteriorate the rubber seals, causing leakage and poor brake performance.
- Refill with the same type of brake fluid: Mixing brake fluids may result in a harmful chemical reaction and lead to poor brake performance.
- Be careful that water does not enter the brake master cylinder when refilling. Water will significantly lower the boiling point of the brake fluid and may result in vapor lock.

## 4.Air bleed:

- Brake system  
Refer to “BLEEDING THE HYDRAULIC BRAKE SYSTEM” in CHAPTER 3.

## 5.Check:

- Brake fluid level  
Brake fluid level is below the “LOWER” level line → Add the recommended brake fluid to the proper level.  
Refer to “CHECKING THE BRAKE FLUID LEVEL” in CHAPTER 3.

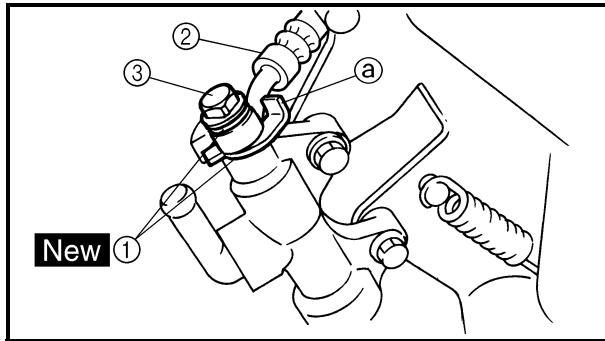

**INSTALLING THE REAR BRAKE MASTER CYLINDER**

1. Install:

- Copper washers ① **New**
- Brake hose ②
- Union bolt ③

**30 Nm (3.0 m • kg, 22 ft • lb)**

**CAUTION:**

When installing the brake hose onto the brake master cylinder, make sure the brake pipe touches the projection ① as shown.

**⚠ WARNING**

Proper brake hose routing is essential to insure safe machine operation. Refer to “CABLE ROUTING”.

2. Fill:

- Brake fluid reservoir



**Recommended brake fluid:  
DOT 4**

**CAUTION:**

Brake fluid may damage painted surfaces or plastic parts. Always clean up spilled brake fluid immediately.

**⚠ WARNING**

- Use only the designated quality brake fluid: Other brake fluids may deteriorate the rubber seals, causing leakage and poor brake performance.
- Refill with the same type of brake fluid: Mixing brake fluids may result in a harmful chemical reaction and lead to poor brake performance.
- Be careful that water does not enter the brake master cylinder when refilling. Water will significantly lower the boiling point of the brake fluid and may result in vapor lock.



### 3. Air bleed:

- Brake system

Refer to “BLEEDING THE HYDRAULIC BRAKE SYSTEM” in CHAPTER 3.

### 4. Check:

- Brake fluid level

Brake fluid level is below the “LOWER” level line → Add the recommended brake fluid to the proper level.

Refer to “CHECKING THE BRAKE FLUID LEVEL” in CHAPTER 3.

FRONT BRAKE CALIPERS

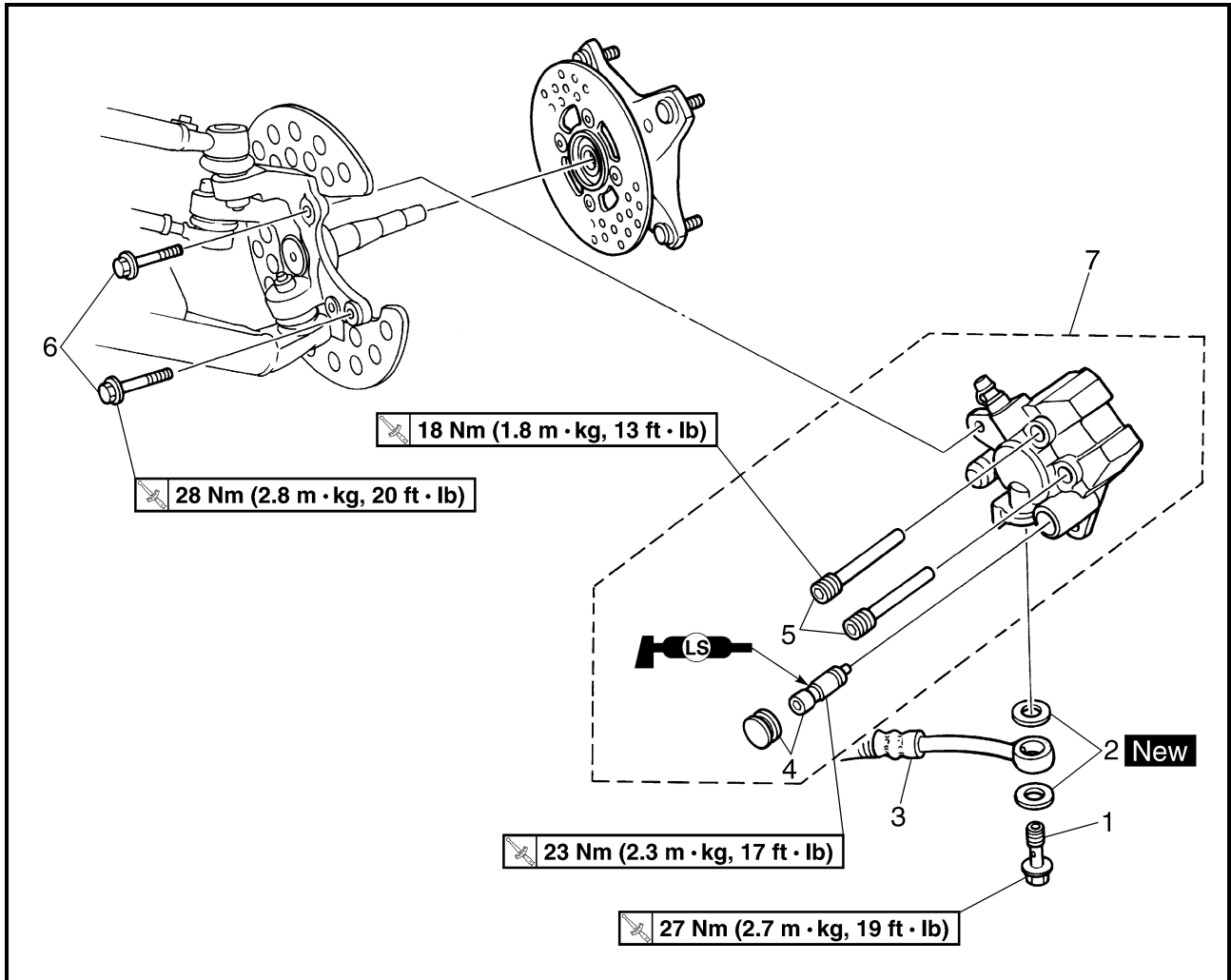

Order	Job name/Part name	Q'ty	Remarks
	<b>Removing the front brake caliper</b>		Remove the parts in the order below.
	Brake fluid		Drain.
	Front wheel		Refer to "FRONT WHEELS".
1	Union bolt	1	Disconnect. Refer to "INSTALLING THE FRONT BRAKE CALIPER". Loosen. Loosen.
2	Copper washer	2	
3	Brake hose	1	
4	Cap/retaining bolt	1/1	
5	Brake pad holding bolt	2	
6	Brake caliper mounting bolt	2	
7	Brake caliper assembly	1	
			For installation, reverse the removal procedure.



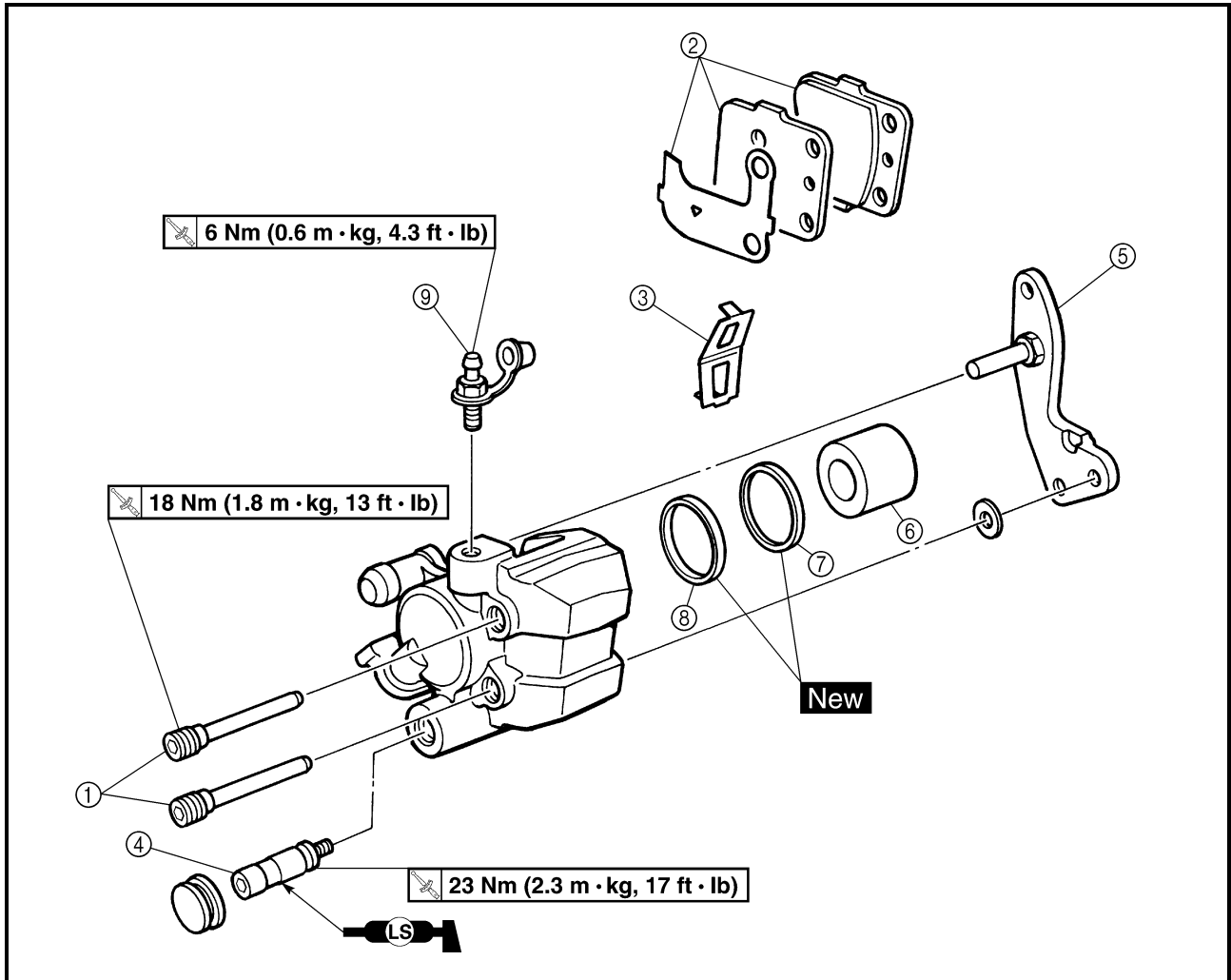

Order	Job name/Part name	Q'ty	Remarks
	<b>Disassembling the front brake caliper</b>		Remove the parts in the order below.
①	Brake pad holding bolt	2	
②	Brake pad/pad shim	2/1	
③	Brake pad spring	1	
④	Retaining bolt	1	
⑤	Caliper bracket	1	
⑥	Brake caliper piston	1	Refer to "DISASSEMBLING THE FRONT AND REAR BRAKE CALIPER/ASSEMBLING THE FRONT BRAKE CALIPER".
⑦	Dust seal	1	
⑧	Caliper piston seal	1	
⑨	Bleed screw	1	
			For assembly, reverse the disassembly procedure.

REAR BRAKE CALIPER

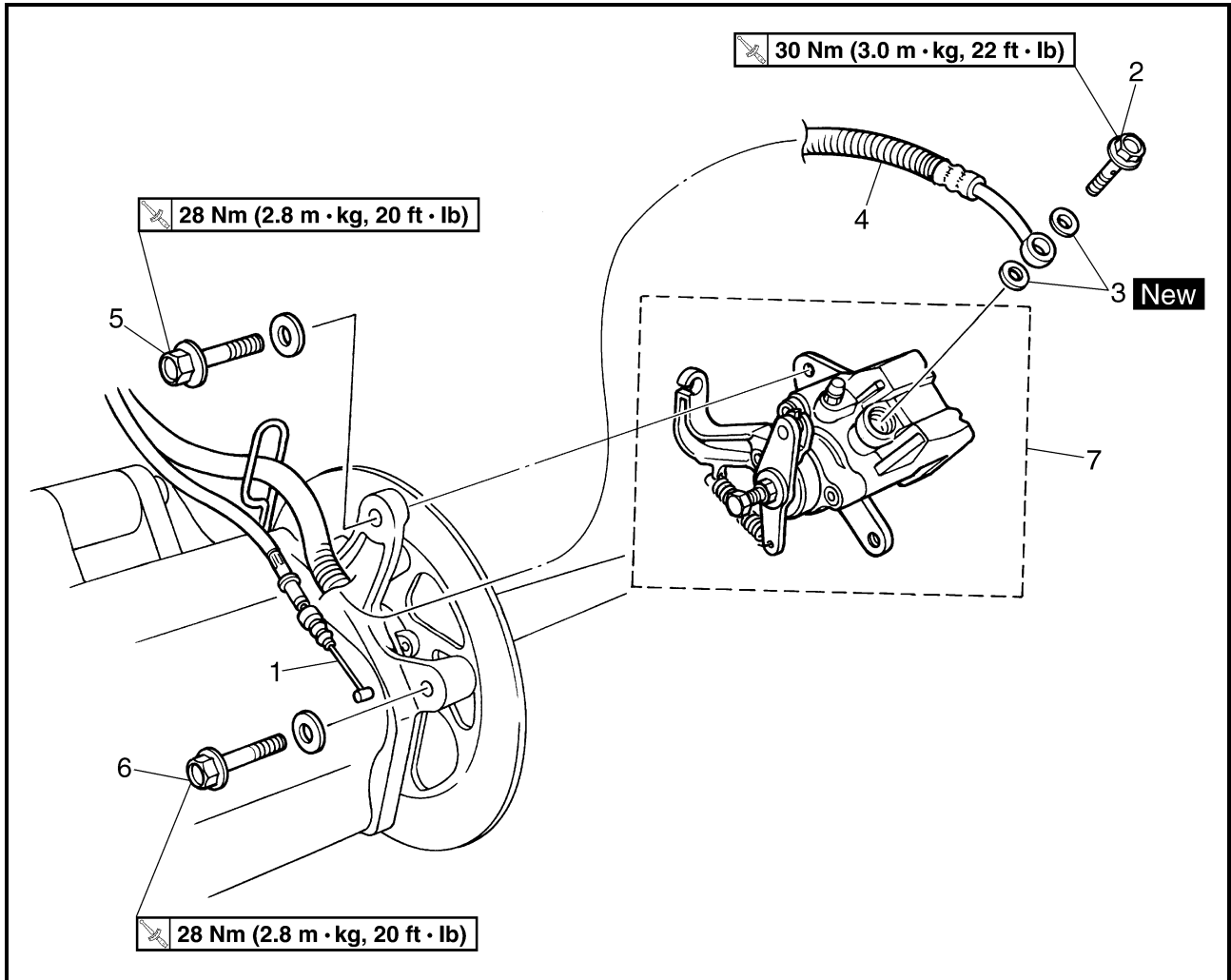

Order	Job name/Part name	Q'ty	Remarks
	<b>Removing the rear brake caliper</b>		Remove the parts in the order below.
	Brake fluid		Drain.
1	Parking brake cable	1	Disconnect.
2	Union bolt	1	
3	Copper washer	2	
4	Brake hose	1	Disconnect.
5	Brake caliper mounting bolt	1	Refer to "INSTALLING THE REAR BRAKE CALIPER".
6	Brake caliper mounting bolt	1	
7	Brake caliper assembly	1	
			For installation, reverse the removal procedure.

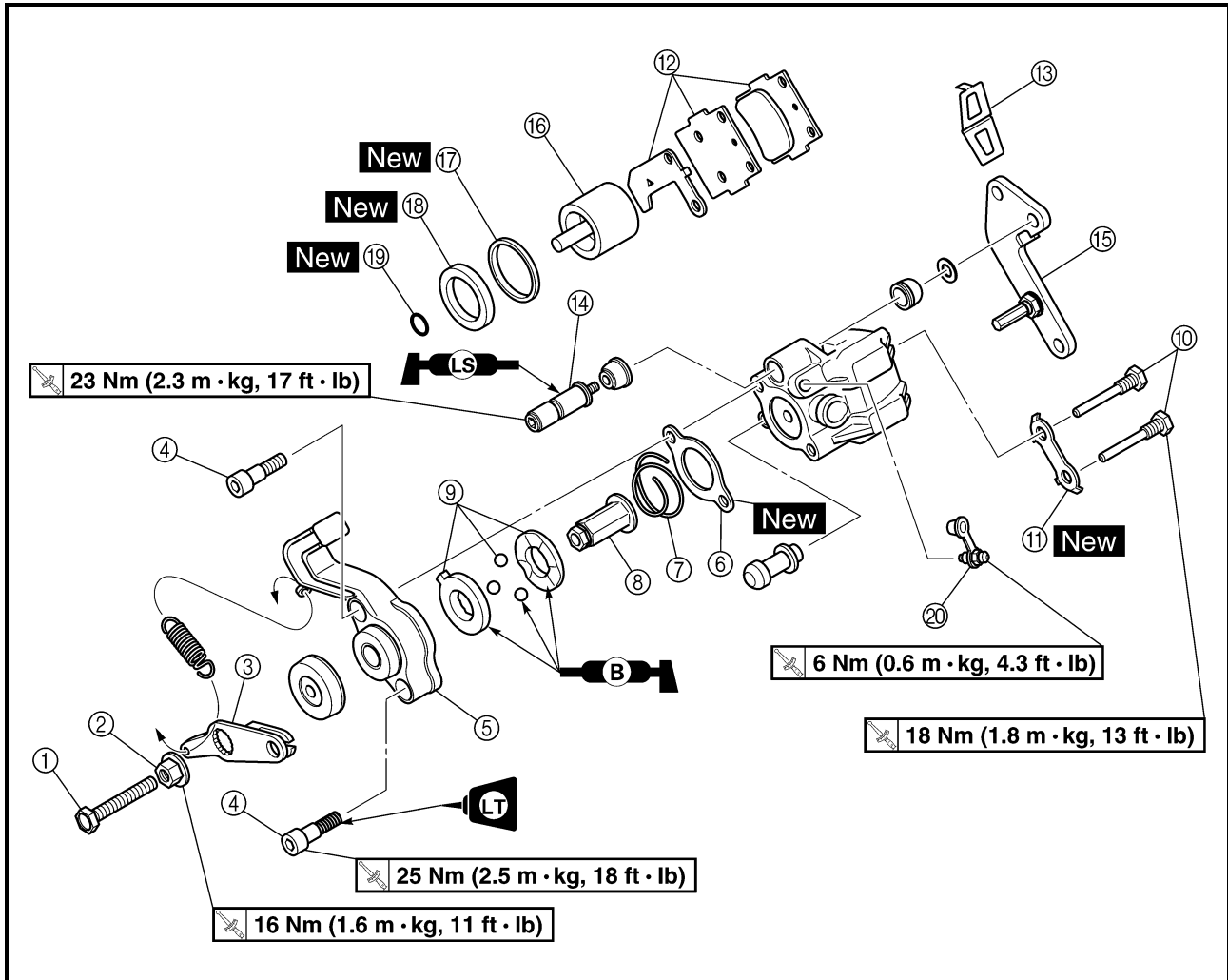

Order	Job name/Part name	Q'ty	Remarks
	<b>Disassembling the rear brake caliper</b>		Remove the parts in the order below.
①	Adjusting bolt	1	
②	Locknut	1	
③	Parking brake lever	1	
④	Parking brake case mounting bolt	2	
⑤	Parking brake case	1	
⑥	Gasket	1	
⑦	Spring	1	
⑧	Nut	1	
⑨	Bearing	1	
⑩	Brake pad holding bolt	2	Refer to "ASSEMBLING THE REAR BRAKE CALIPER".
⑪	Lock washer	1	

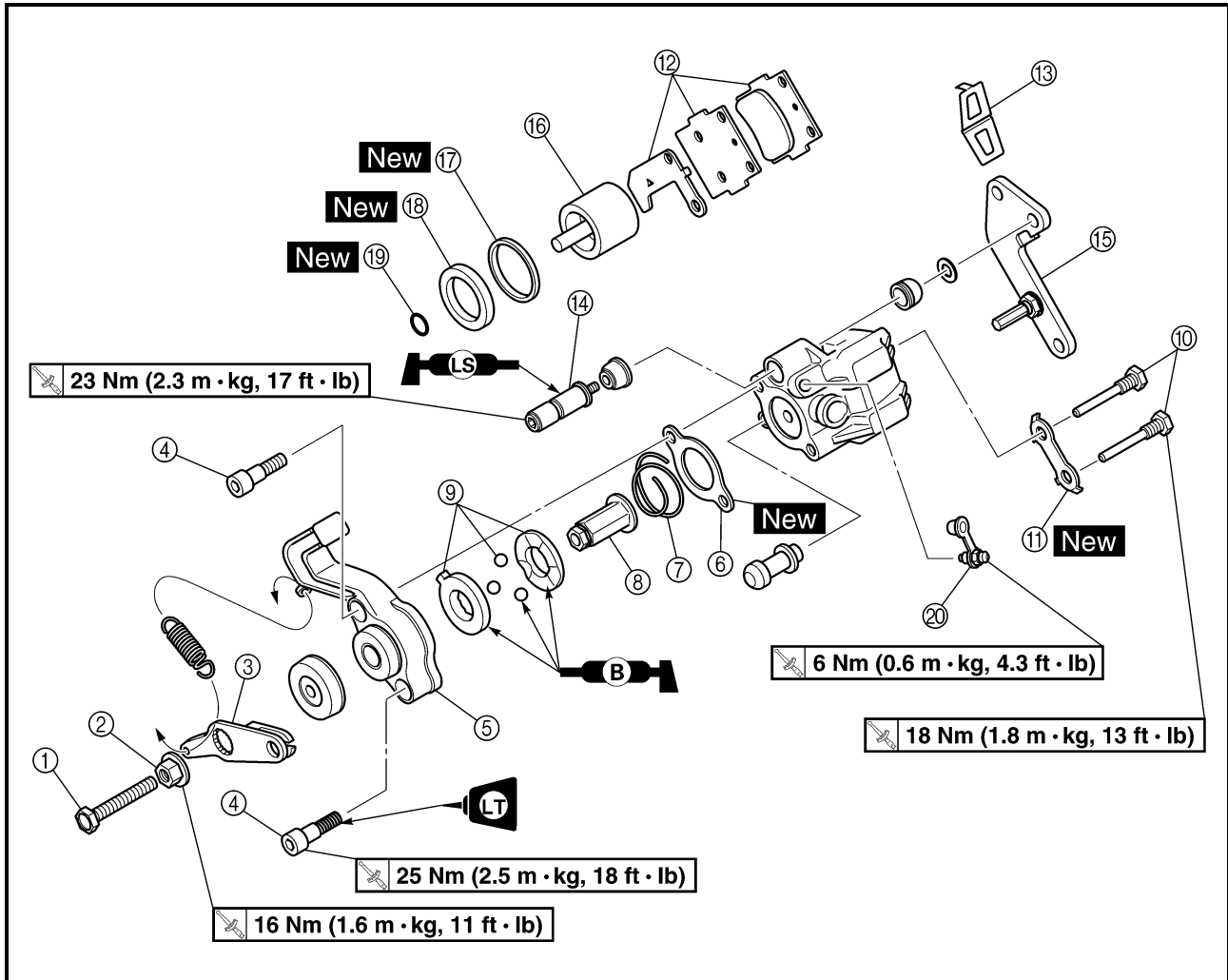

Order	Job name/Part name	Q'ty	Remarks
⑫	Brake pad/pad shim	2/1	Refer to "DISASSEMBLING THE FRONT AND REAR BRAKE CALIPER/ASSEMBLING THE REAR BRAKE CALIPER".
⑬	Brake pad spring	1	
⑭	Retaining bolt	1	
⑮	Caliper bracket	1	
⑯	Brake caliper piston	1	
⑰	Dust seal	1	
⑱	Caliper piston seal	1	
⑲	O-ring	1	
⑳	Bleed screw	1	
			For assembly, reverse the disassembly procedure.

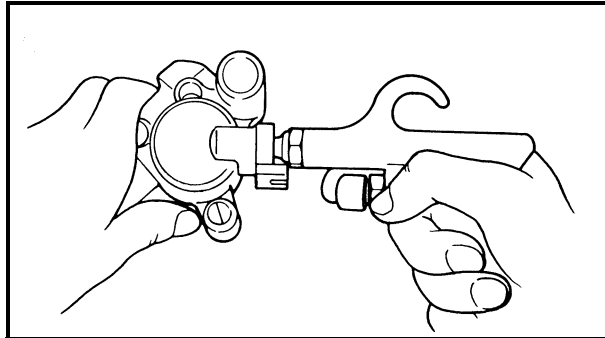
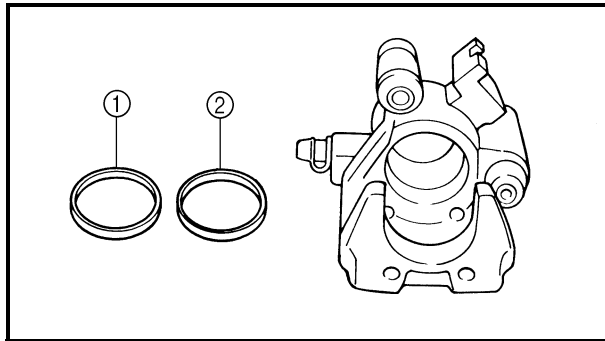

**DISASSEMBLING THE FRONT AND REAR BRAKE CALIPER**

1. Remove:

- Brake caliper piston
- Dust seal ①
- Caliper piston seal ②

\*\*\*\*\*

**Removal steps:**

- Blow compressed air into the hose joint opening to force out the caliper piston from the brake caliper body.

**⚠ WARNING**

- Never try to pry out the caliper piston.
- Cover the caliper piston with a rag. Be careful not to get injured when the piston is expelled from the master cylinder.

- Remove the caliper piston seals.

\*\*\*\*\*

EB702040

**CHECKING THE FRONT AND REAR BRAKE CALIPER**

Recommended brake component replacement schedule:	
Brake pads	As required
Piston seal, dust seal	Every two years
Brake hoses	Every two years
Brake fluid	Replace when brakes are disassembled.

**⚠ WARNING**

All internal brake components should be cleaned in new brake fluid only. Do not use solvents as they will cause seals to swell and distort.

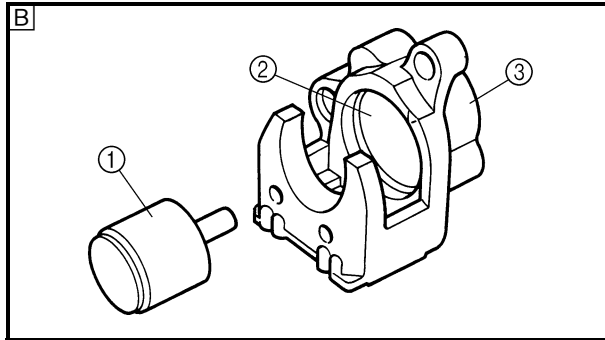
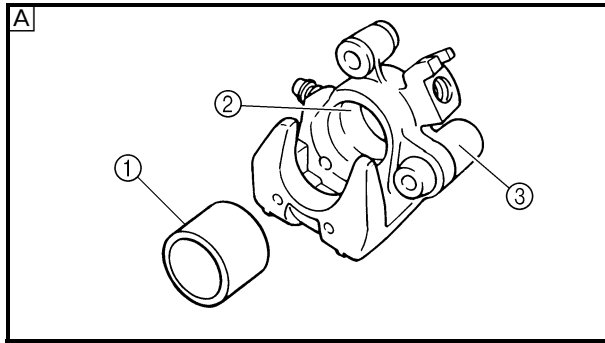

1. Check:

- Brake caliper piston ①  
Scratches/rust/wear → Replace the brake caliper assembly.
- Brake caliper cylinder ②  
Wear/scratches → Replace the brake caliper assembly.
- Brake caliper body ③  
Cracks/damage → Replace.
- Brake fluid delivery passage (brake caliper body)  
Blockage → Blow out with compressed air.

**⚠ WARNING**

Replace the caliper piston seal and dust seal whenever the brake caliper is disassembled.

- Ⓐ Front
- Ⓑ Rear

## ASSEMBLING THE FRONT BRAKE CALIPER

**⚠ WARNING**

- All internal brake components should be cleaned and lubricated with new brake fluid only before installation.



Recommended brake fluid:  
DOT 4

- Replace the caliper piston seal whenever a brake caliper is disassembled.

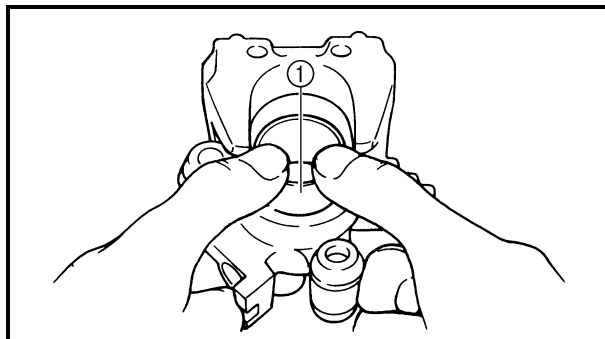
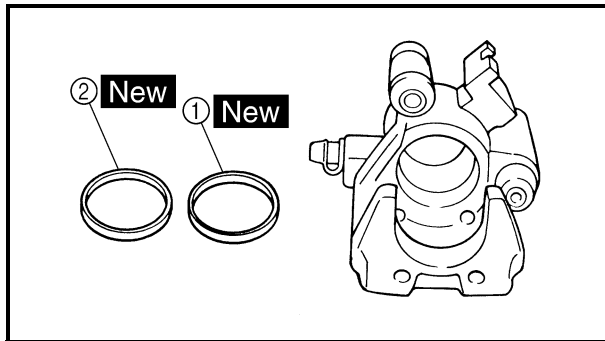

1. Install:

- Caliper piston seal ① **New**
- Dust seal ② **New**

2. Install:

- Brake caliper piston ①



ASSEMBLING THE REAR BRAKE CALIPER

**⚠ WARNING**

- All internal brake components should be cleaned and lubricated with new brake fluid only before installation.



Recommended brake fluid:  
DOT 4

- Replace the caliper piston seal whenever a brake caliper is disassembled.

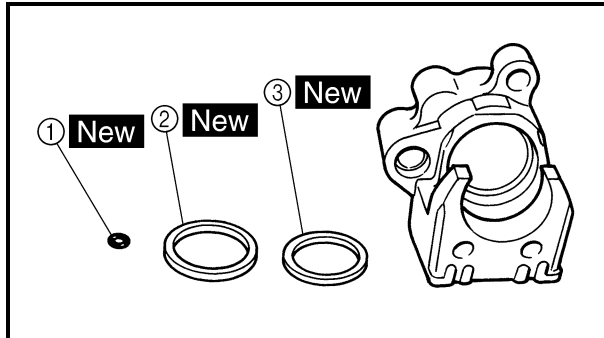

1. Install:

- O-ring ① **New**
- Caliper piston seal ② **New**
- Dust seal ③ **New**

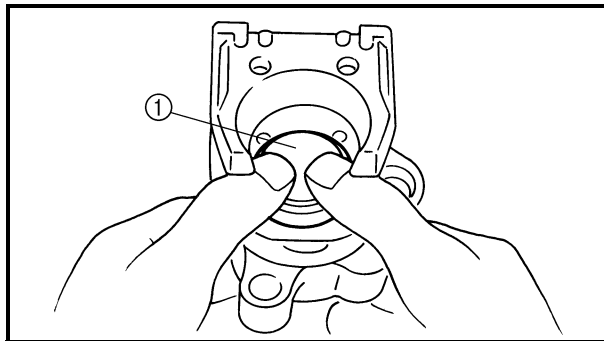

2. Install:

- Brake caliper piston ①

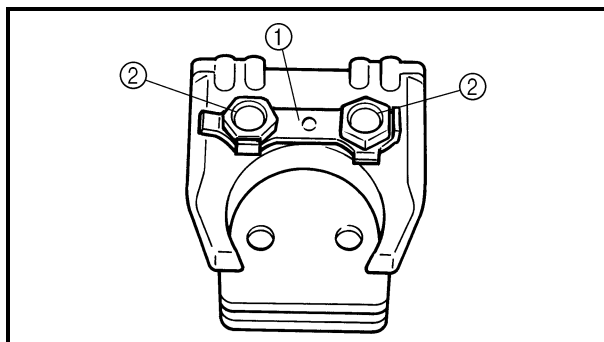

3. Install:

- Lock washer ① **New**
- Brake pad holding bolts ②

**18 Nm (1.8 m • kg, 13 ft • lb)**

- 4. Bend the lock washer tabs along a flat side of the bolts.

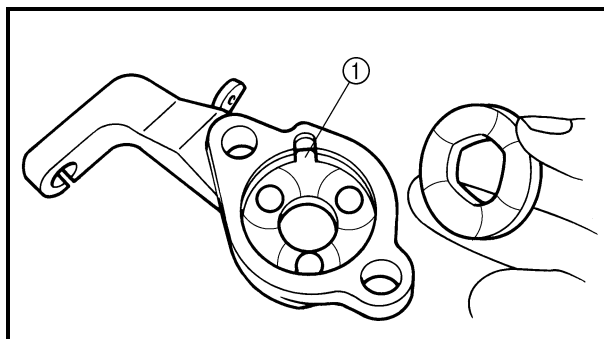

- 5. Mesh the bearing race tab ① with parking brake case slit.

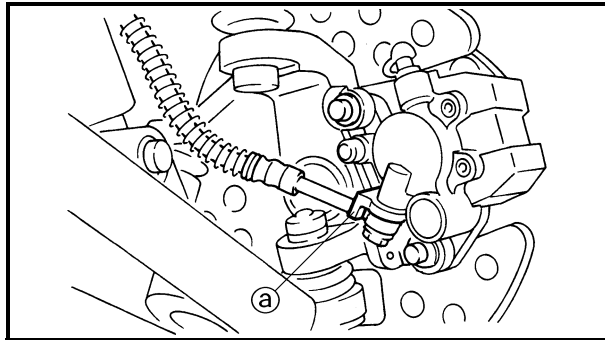
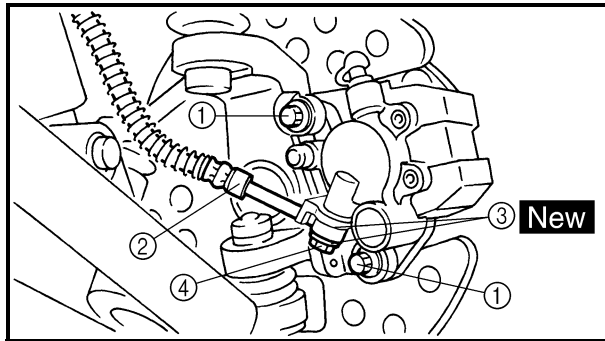

**INSTALLING THE FRONT BRAKE CALIPER**

1. Install:

- Brake caliper assembly
- Brake caliper mounting bolts ①

28 Nm (2.8 m • kg, 20 ft • lb)

- Brake hose ②
- Copper washers ③ **New**
- Union bolt ④

27 Nm (2.7 m • kg, 19 ft • lb)

**CAUTION:**

When installing the brake hose on the brake caliper, make sure that the brake pipe touches the projection ① on the brake caliper.

**⚠ WARNING**

Proper brake hose routing is essential to insure safe motorcycle operation. Refer to “CABLE ROUTING”.

2. Fill:

- Brake reservoir



Recommended brake fluid:  
DOT 4

**CAUTION:**

Brake fluid may damage painted surfaces or plastic parts. Always clean up spilled brake fluid immediately.

**⚠ WARNING**

- Use only the designated quality brake fluid: Other brake fluids may deteriorate the rubber seals, causing leakage and poor brake performance.
- Refill with the same type of brake fluid: Mixing brake fluids may result in a harmful chemical reaction and lead to poor brake performance.
- Be careful that water does not enter the master cylinder when refilling. Water will significantly lower the boiling point of the brake fluid and may result in vapor lock.

3. Air bleed

- Brake system  
Refer to “BLEEDING THE HYDRAULIC BRAKE SYSTEM” in CHAPTER 3.





4. Check:

- Brake fluid level  
 Brake fluid level is below the “LOWER” level line → Add the recommended brake fluid to the proper level.  
 Refer to “CHECKING THE BRAKE FLUID LEVEL” in CHAPTER 3.

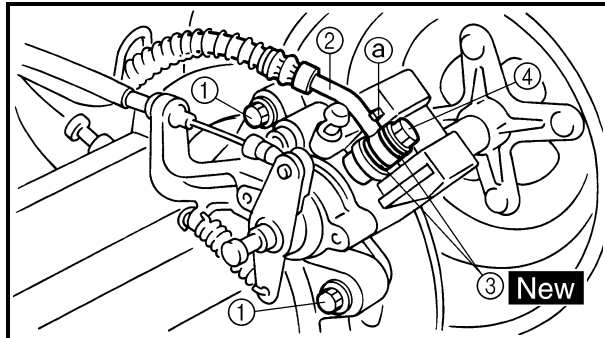

**INSTALLING THE REAR BRAKE CALIPER**

1. Install:

- Brake caliper assembly
- Brake caliper mounting bolts ① 

	28 Nm (2.8 m • kg, 20 ft • lb)
--	--------------------------------
- Brake hose ②
- Copper washers ③ **New**
- Union bolt ④ 

	30 Nm (3.0 m • kg, 22 ft • lb)
--	--------------------------------

**CAUTION:**

When installing the brake hose on the brake caliper, make sure that the brake pipe touches the projection ③ on the brake caliper.

**⚠ WARNING**

Proper brake hose routing is essential to insure safe motorcycle operation. Refer to “CABLE ROUTING”.

2. Fill:

- Brake reservoir



**Recommended brake fluid:  
DOT 4**

**CAUTION:**

Brake fluid may damage painted surfaces or plastic parts. Always clean up spilled brake fluid immediately.

**⚠ WARNING**

- Use only the designated quality brake fluid: Other brake fluids may deteriorate the rubber seals, causing leakage and poor brake performance.
- Refill with the same type of brake fluid: Mixing brake fluids may result in a harmful chemical reaction and lead to poor brake performance.
- Be careful that water does not enter the master cylinder when refilling. Water will significantly lower the boiling point of the brake fluid and may result in vapor lock.

## 3. Air bleed

- Brake system  
Refer to “BLEEDING THE HYDRAULIC BRAKE SYSTEM” in CHAPTER 3.

## 4. Check:

- Brake fluid level  
Brake fluid level is below the “LOWER” level line → Add the recommended brake fluid to the proper level.  
Refer to “CHECKING THE BRAKE FLUID LEVEL” in CHAPTER 3.

## 5. Adjust:

- Parking brake cable end length  
Refer to “ADJUSTING THE PARKING BRAKE” in CHAPTER 3.



**STEERING SYSTEM**  
**HANDLEBAR**

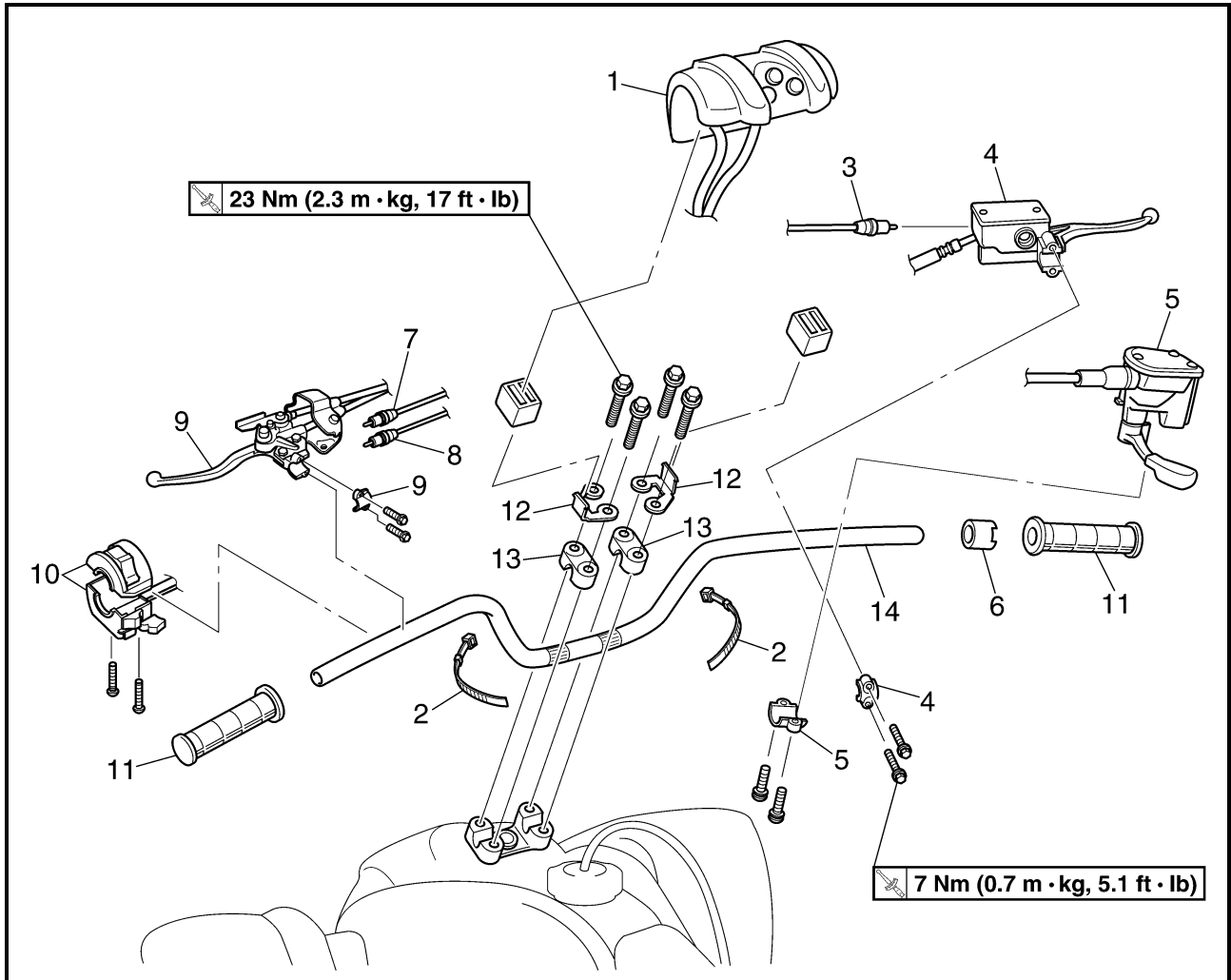

Order	Job name/Part name	Q'ty	Remarks
	<b>Removing the handlebar</b>		Remove the parts in the order below.
1	Handlebar cover	1	
2	Band	2	
3	Front brake switch	1	Refer to "REMOVING THE FRONT BRAKE SWITCH, PARK SWITCH AND CLUTCH SWITCH".
4	Brake master cylinder/bracket	1/1	Refer to "INSTALLING THE BRAKE MASTER CYLINDER".
5	Throttle lever assembly/bracket	1/1	
6	Collar	1	
7	Park switch	1	Refer to "REMOVING THE FRONT BRAKE SWITCH, PARK SWITCH AND CLUTCH SWITCH".
8	Clutch switch	1	
9	Clutch lever/bracket	1/1	Refer to "INSTALLING THE CLUTCH LEVER".
10	Handlebar switch	1	

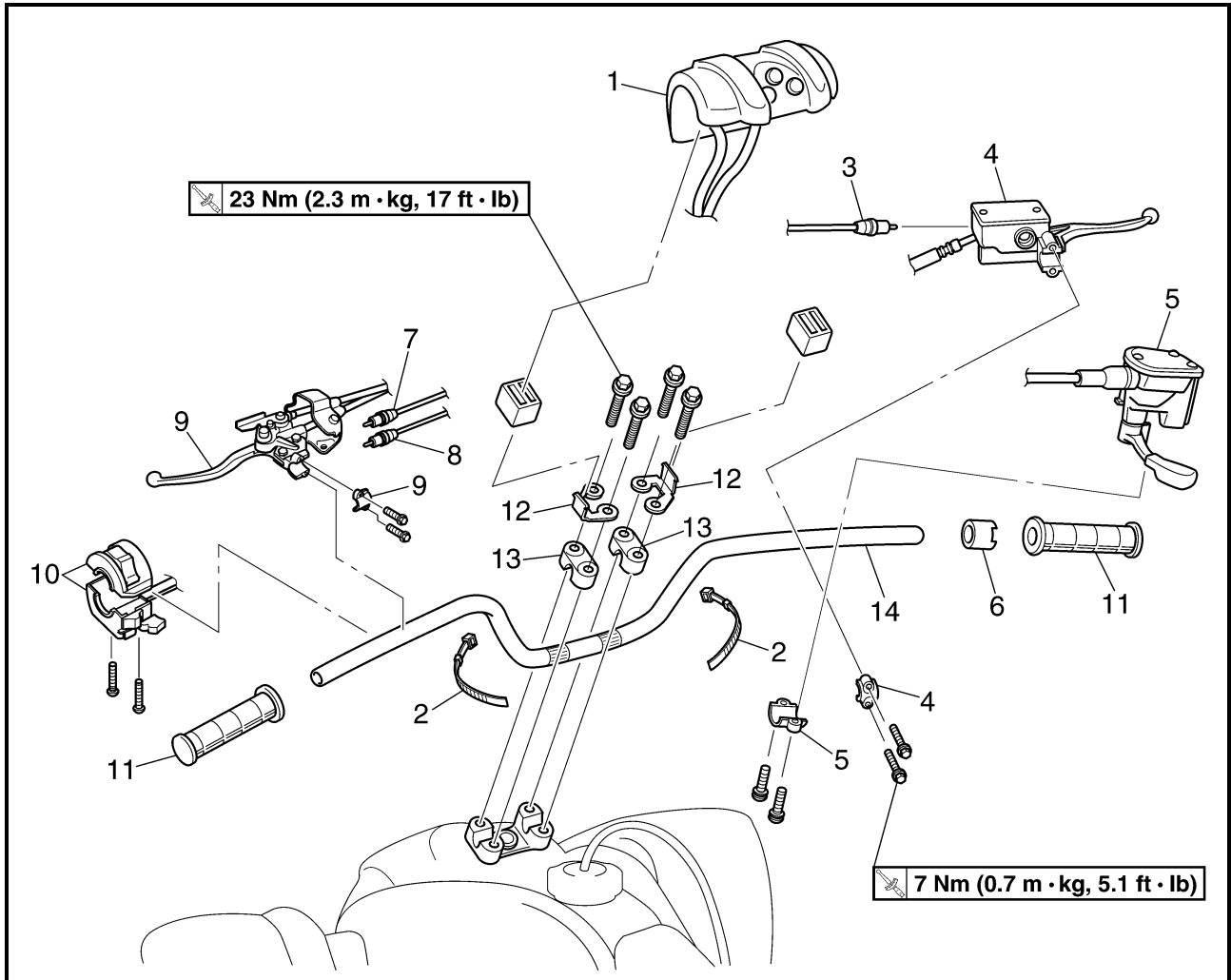

Order	Job name/Part name	Q'ty	Remarks
11	Handlebar grip	2	Refer to "REMOVING/INSTALLING THE HANDLEBAR GRIP".
12	Handlebar cover bracket	2	
13	Handlebar holder	2	
14	Handlebar	1	
			Refer to "INSTALLING THE HANDLEBAR".
			For installation, reverse the removal procedure.

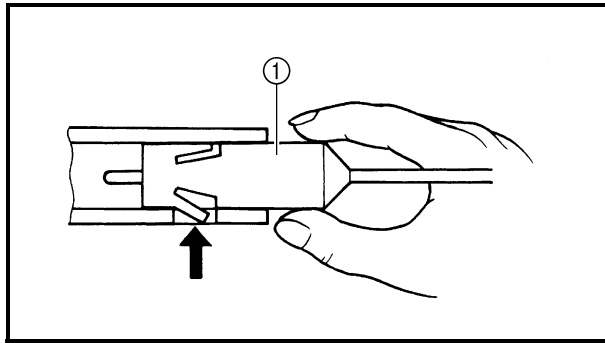

### REMOVING THE FRONT BRAKE SWITCH, PARK SWITCH AND CLUTCH SWITCH

1.Remove:

- Front brake switch ①
- Park switch
- Clutch switch

#### NOTE:

- Push the fastener when removing the front brake switch out of the brake master cylinder.
- Push the fastener when removing the park switch and clutch switch out of the clutch lever holder.

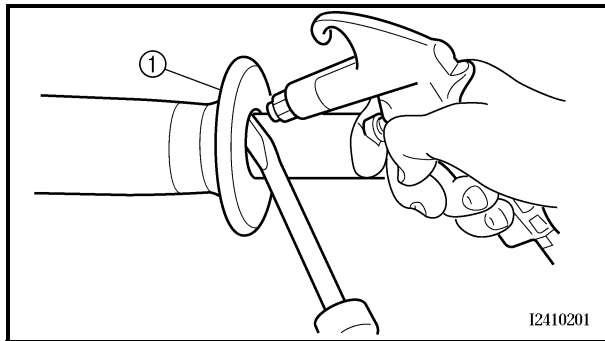

### REMOVING THE HANDLEBAR GRIP

1.Remove:

- Handlebar grips ①

#### NOTE:

- Blow compressed air between the handlebar and handlebar grip, and gradually push the grip off the handlebar.

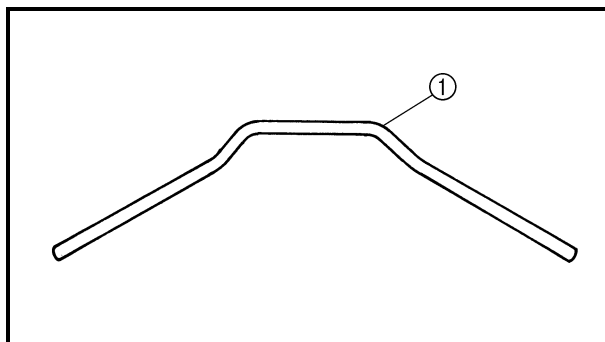

### CHECKING THE HANDLEBAR

1.Check:

- Handlebar ①  
Bends/cracks/damage → Replace.

#### ⚠ WARNING

Do not attempt to straighten a bent handlebar as this may dangerously weaken the handlebar.

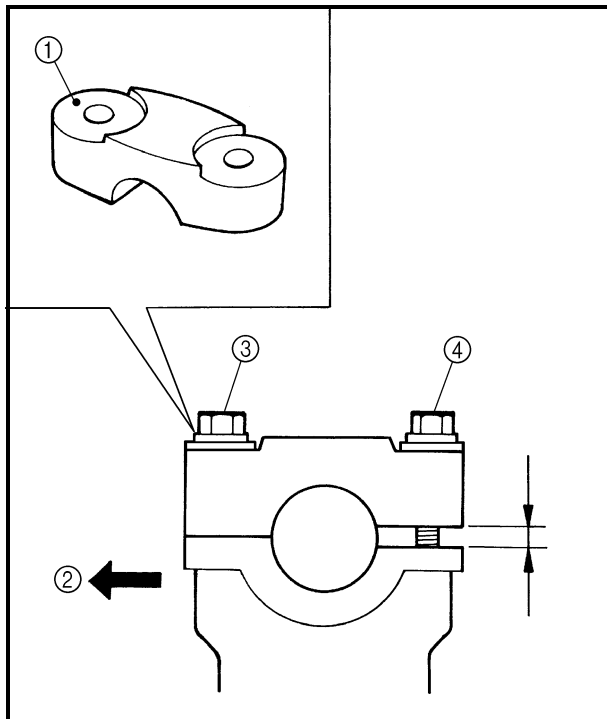

**INSTALLING THE HANDLEBAR**

1. Install:

- Handlebar
- Handlebar holders
- Handlebar cover brackets

23 Nm (2.3 m • kg, 17 ft • lb)

**NOTE:**

The upper handlebar holder should be installed with the punched mark ① forward ②.

**CAUTION:**

First tighten the bolts ③ on the front side of the handlebar holder, and then tighten the bolts ④ on the rear side.

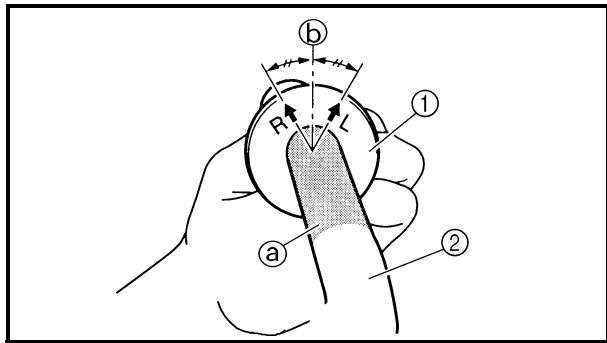

**INSTALLING THE HANDLEBAR GRIP**

1. Install:

- Handlebar grips ①

**NOTE:**

- Before applying the adhesive, wipe off grease or oil on the handlebar surface ① with a lacquer thinner.
- Install the handlebar grips to the handlebar so that the line ② between the two arrow marks faces straight upward.

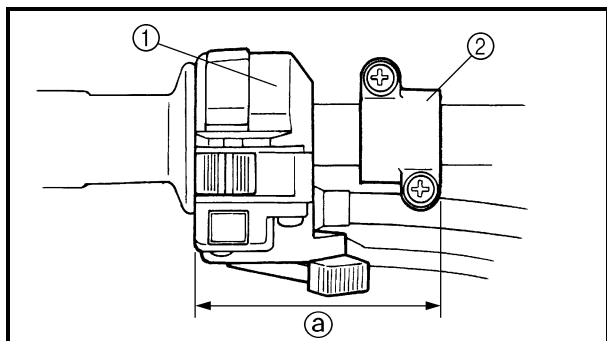

**INSTALLING THE CLUTCH LEVER**

1. Install:

- Handlebar switch ①
- Clutch lever
- Lever bracket ②

**NOTE:**

Install the lever bracket as shown.

① 80 mm (3.1 in)

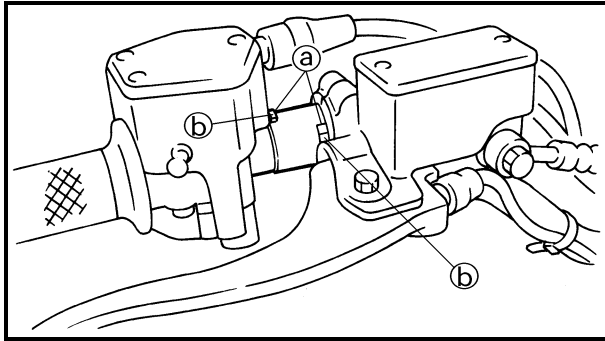

### INSTALLING THE BRAKE MASTER CYLINDER

1. Install:

- Throttle lever assembly
- Collar
- Brake master cylinder

 7 Nm (0.7 m • kg, 5.1 ft • lb)

#### NOTE:

- Engage the indentations ① in the collar with the lobes ② on the throttle lever assembly and brake master cylinder.
- The “UP” mark on the brake master cylinder bracket should face up.



STEERING STEM

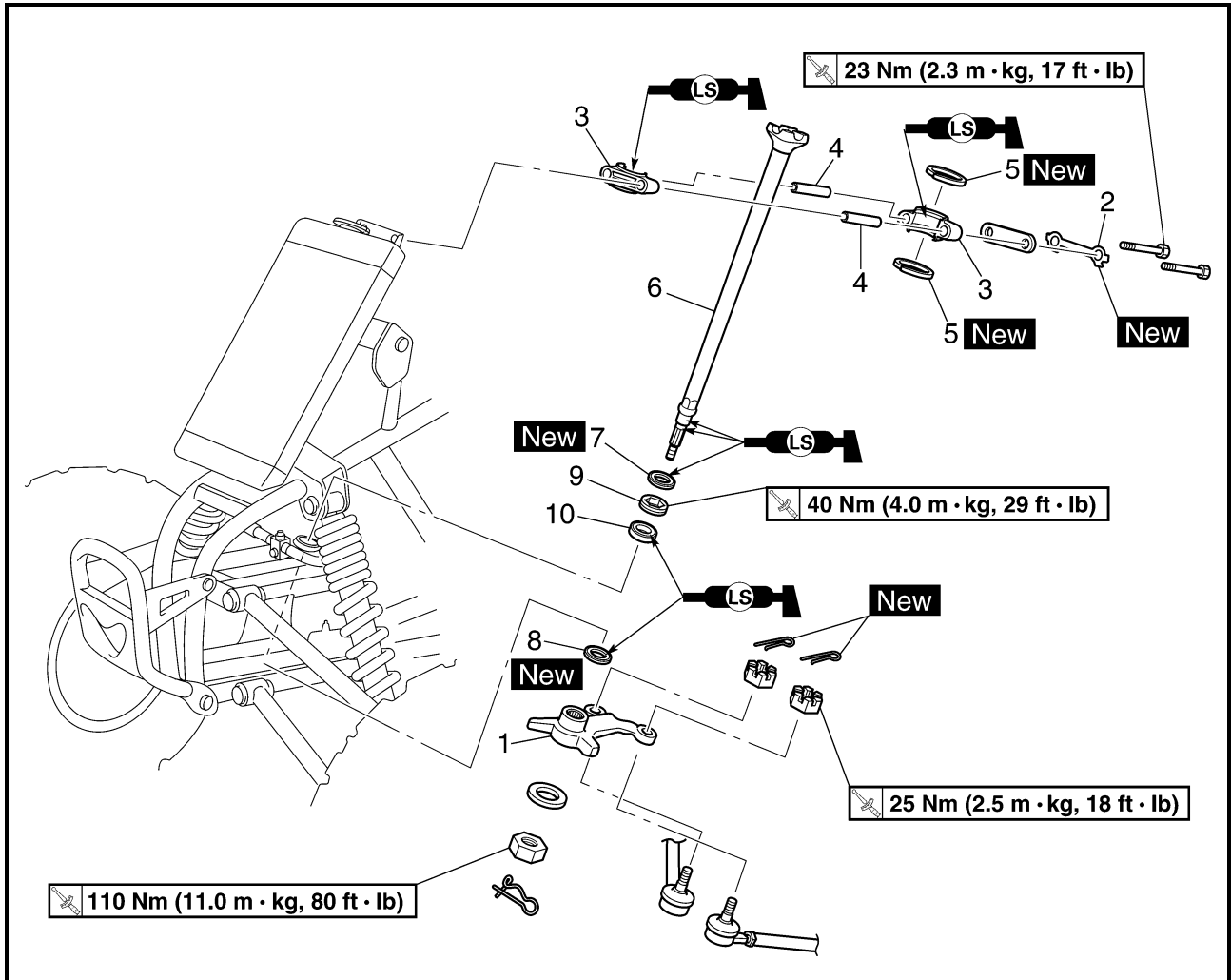

Order	Job name/Part name	Q'ty	Remarks
	<b>Removing the steering stem</b>		Remove the parts in the order below.
	Front fender		Refer to "SEAT, FENDERS AND FUEL TANK" in CHAPTER 3.
	Fuel tank		Refer to "SEAT, FENDERS AND FUEL TANK" in CHAPTER 3.
	Handlebar		Refer to "HANDLEBAR".
1	Pitman arm	1	
2	Lock washer	1	Refer to "INSTALLING THE LOCK WASHER".
3	Steering stem bushing	2	
4	Collar	2	
5	Oil seal	2	
6	Steering stem	1	
7	Oil seal	1	
8	Oil seal	1	



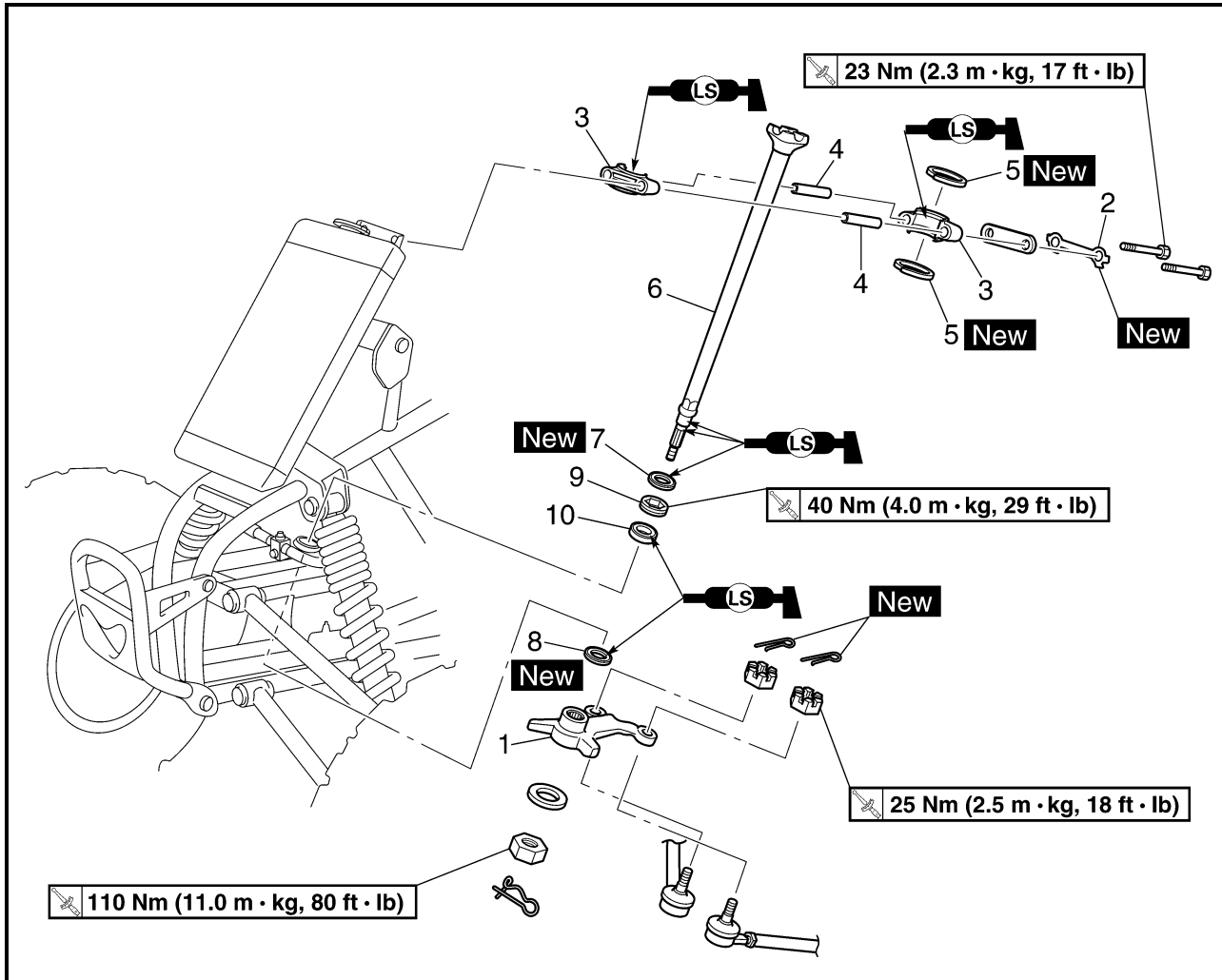

Order	Job name/Part name	Q'ty	Remarks
9	Bearing retainer	1	Refer to "REMOVING/INSTALLING THE BEARING RETAINER".
10	Bearing	1	For installation, reverse the removal procedure.



## REMOVING THE BEARING RETAINER

1.Remove:

- Bearing retainer (steering stem)



**Damper rod holder:**  
P/N. YM-01327, 90890-01327

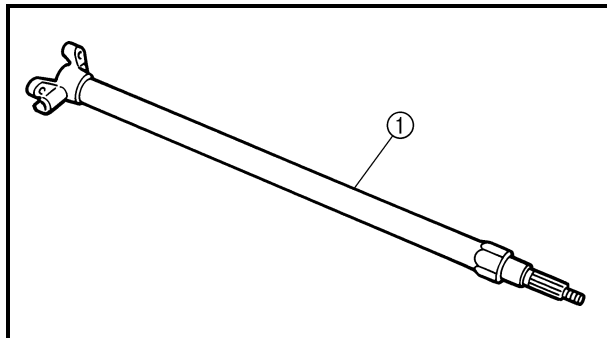

## CHECKING THE STEERING STEM

1.Check:

- Steering stem ①  
Bends → Replace.

### **⚠ WARNING**

**Do not attempt to straighten a bent stem; this may dangerously weaken the stem.**

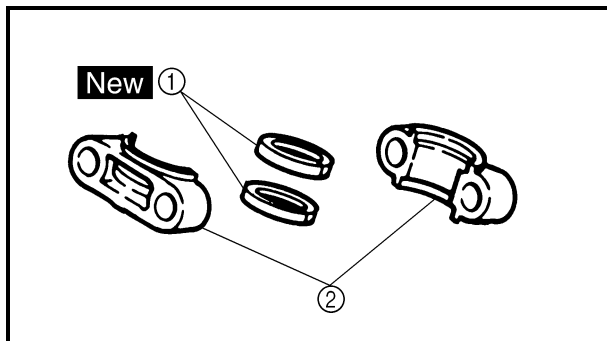

2.Check:

- Oil seals ① **New**
- Steering stem bushings ②  
Wear/damage → Replace.

## INSTALLING THE BEARING RETAINER

1.Install:

- Bearing retainer (steering stem)

**40 Nm (4.0 m • kg, 29 ft • lb)**



**Damper rod holder:**  
P/N. YM-01327, 90890-01327

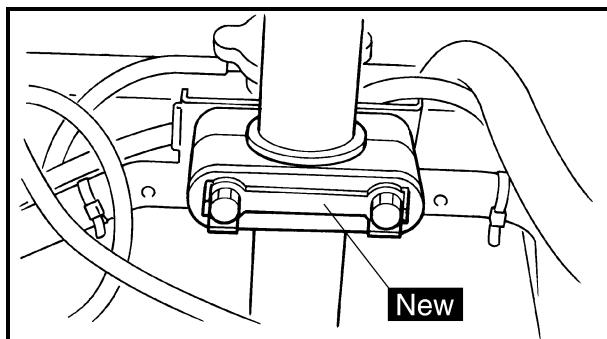

## INSTALLING THE LOCK WASHER

1.Install:

- Lock washer **New**

**23 Nm (2.3 m • kg, 17 ft • lb)**

- 2.Bend the lock washer tab along a flat side of the bolt.



TIE-ROD AND STEERING KNUCKLE

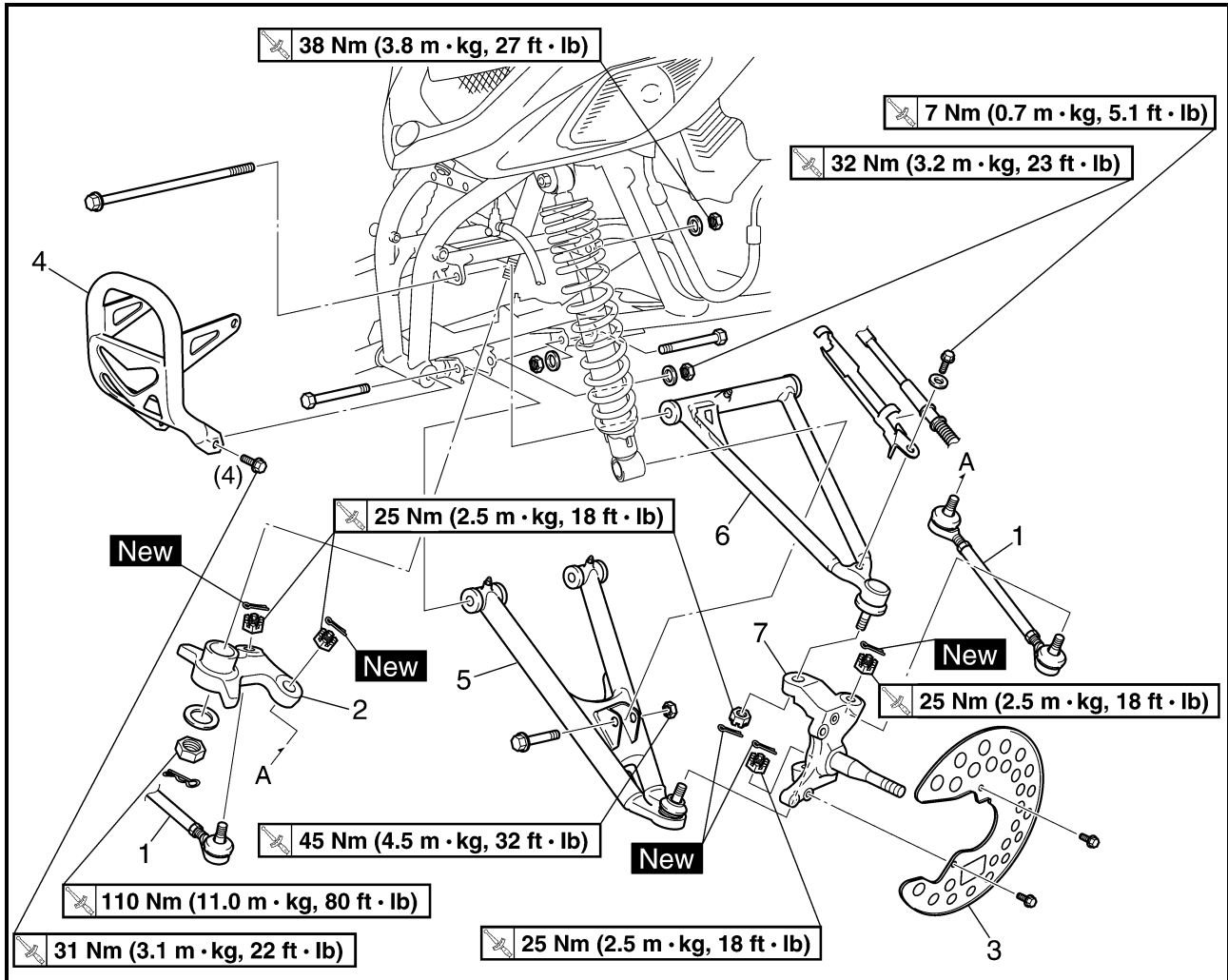

Order	Job name/Part name	Q'ty	Remarks
	<b>Removing the tie-rod and steering knuckle</b>		Remove the parts in the order below.
	Front wheel/brake disc		Refer to "FRONT WHEELS".
1	Tie-rod	2	Refer to "INSTALLING THE TIE-ROD".
2	Pitman arm	1	
3	Brake disc guard (inner)	1	
4	Front bumper	1	
5	Front arm (lower)	1	
6	Front arm (upper)	1	
7	Steering knuckle	1	Refer to "REMOVING THE STEERING KNUCKLE". For installation, reverse the removal procedure.

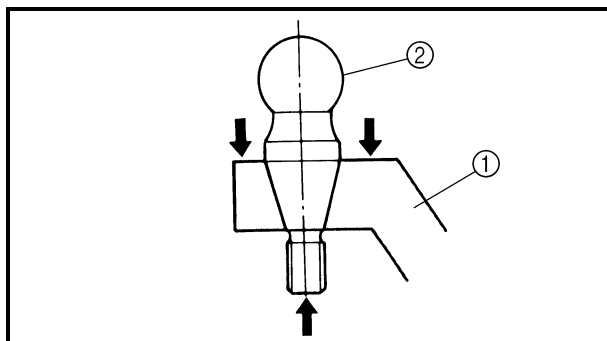

**REMOVING THE STEERING KNUCKLE**

- 1.Remove:
- Steering knuckle ①

**NOTE:** \_\_\_\_\_  
 Use a general puller to separate the ball joint ② and steering knuckle.

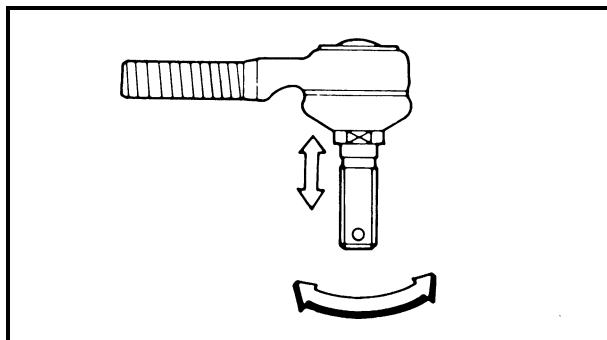

**CHECKING THE TIE-ROD**

- 1.Check:
- Tie-rod free play and movement  
 Free play → Replace the tie-rod end.  
 Turns roughly → Replace the tie-rod end.
- 2.Check:
- Tie-rod
  - Bends/damage → Replace.

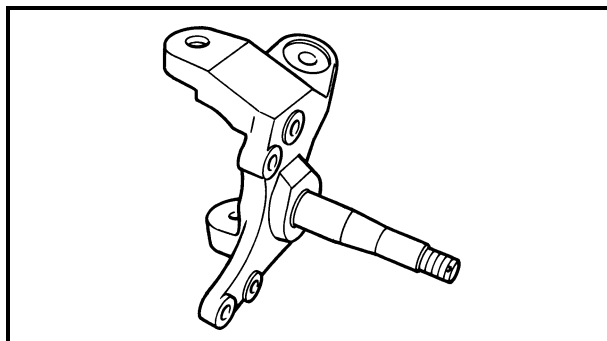

**CHECKING THE STEERING KNUCKLE**

- 1.Check:
- Steering knuckle  
 Damage/pitting → Replace.

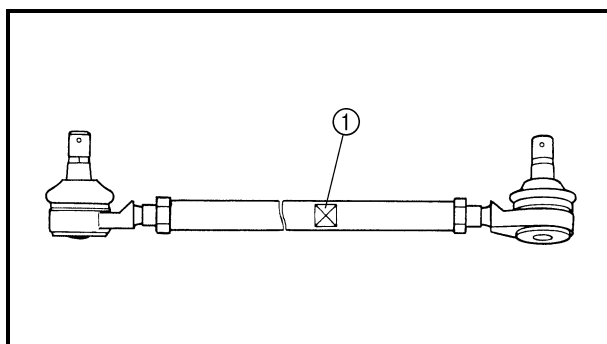

**INSTALLING THE TIE-ROD**

- 1.Install:
- Tie-rods (left and right)

**25 Nm (2.5 m • kg, 18 ft • lb)**

**NOTE:** \_\_\_\_\_  
 The tie-rod which must be installed on the out side has grooves ①.

- 2.Adjust:
- Toe-in  
 Refer to “ADJUSTING THE TOE-IN” in CHAPTER 3.

FRONT ARMS AND FRONT SHOCK ABSORBERS

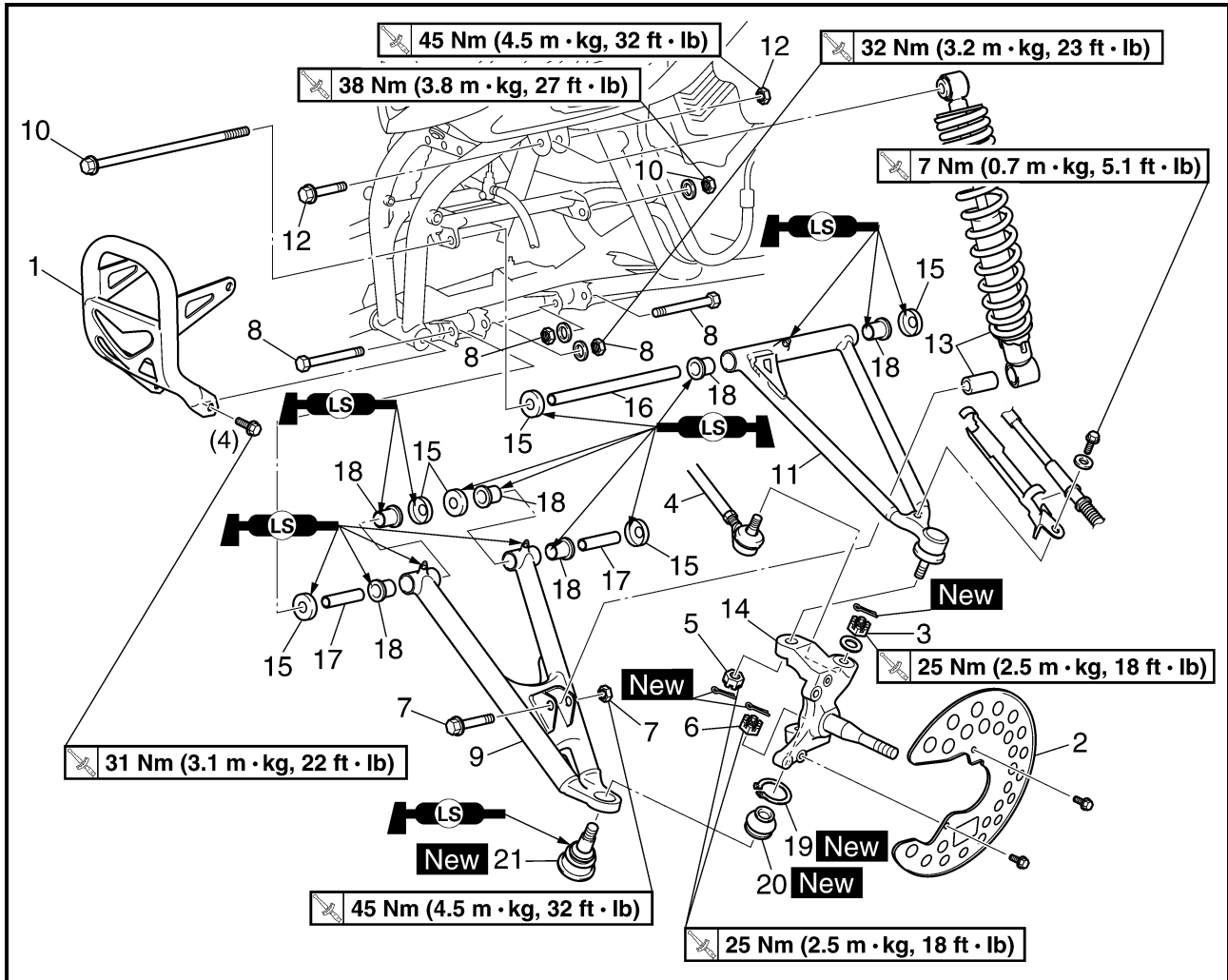

Order	Job name/Part name	Q'ty	Remarks
	<b>Removing the front arm and front shock absorber</b>		Remove the parts in the order below.
	Front wheel/brake disc		Refer to "FRONT WHEELS".
1	Front bumper	1	
2	Brake disc guard (inner)	1	
3	Nut	1	
4	Tie-rod	1	Disconnect.
5	Nut	1	
6	Nut	1	
7	Nut/bolt	1/1	
8	Nut/bolt	2/2	
9	Front arm (lower)	1	Refer to "REMOVING/INSTALLING THE FRONT ARMS".
10	Nut/bolt	1/1	
11	Front arm (upper)	1	

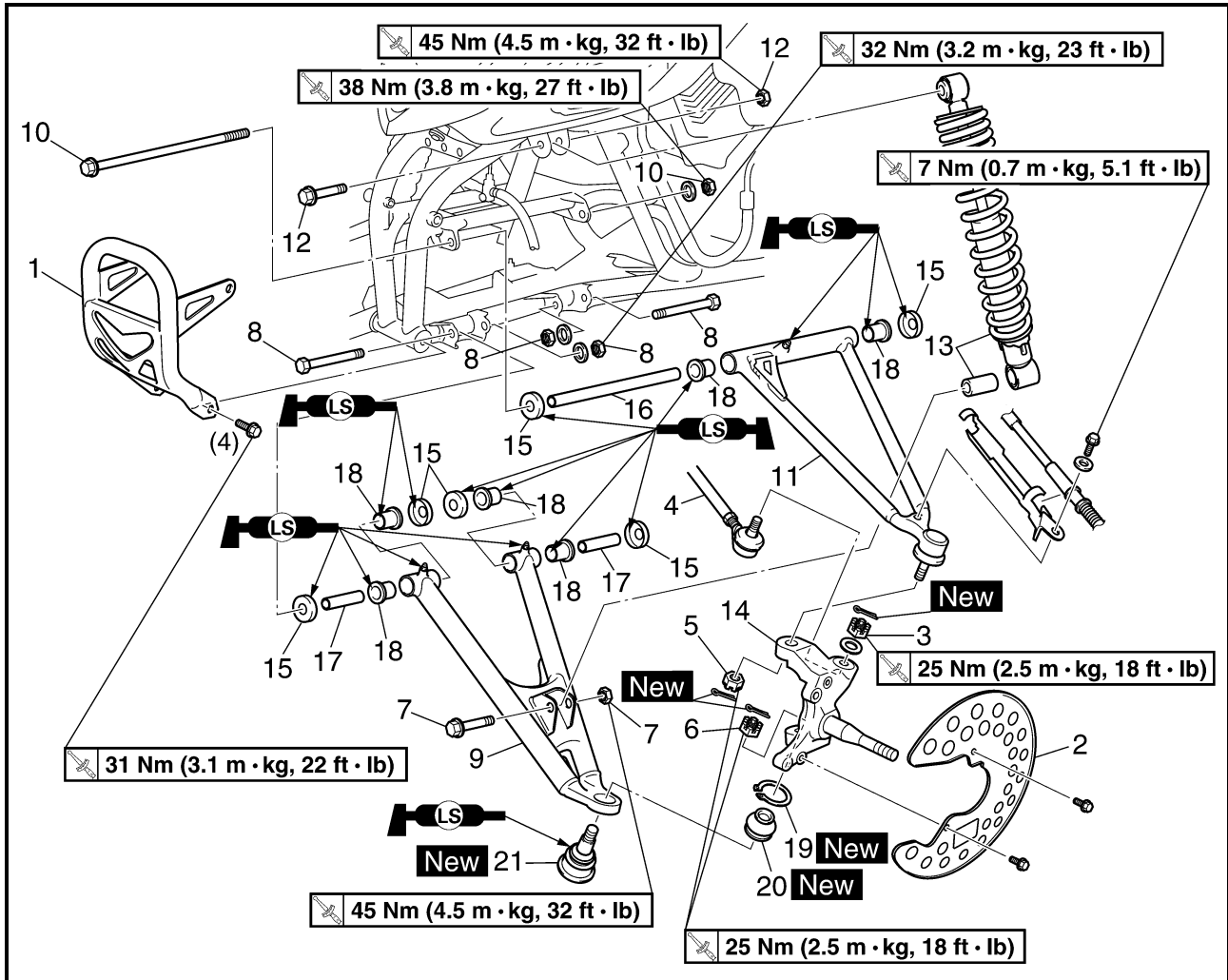

Order	Job name/Part name	Q'ty	Remarks
12	Nut/bolt	1/1	
13	Front shock absorber/collar	1/1	
14	Steering knuckle	1	
15	Dust cover	6	
16	Collar	1	
17	Collar	2	
18	Bushing	6	
19	Circlip	1	
20	Rubber boot	1	
21	Ball joint	1	
			For installation, reverse the removal procedure.

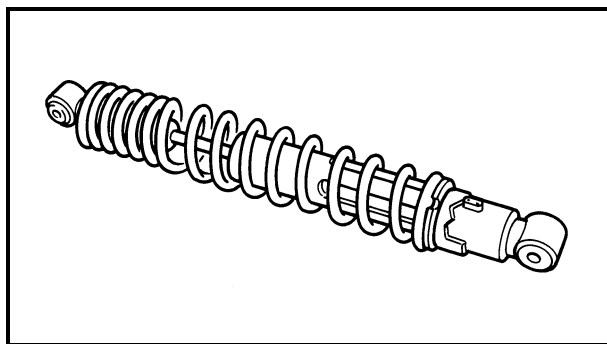
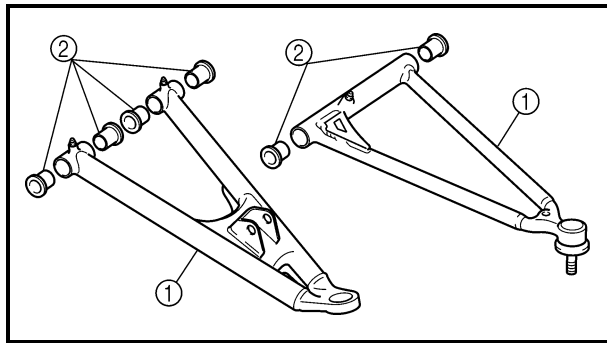
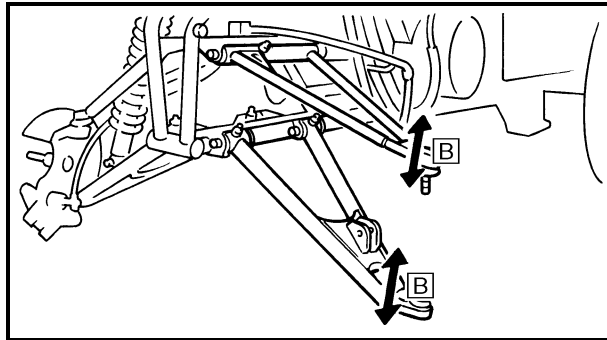
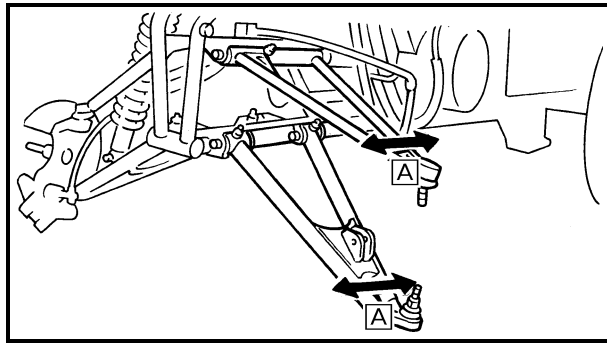

## REMOVING THE FRONT ARM

1. Check:

- Front arm free play

\*\*\*\*\*

### Checking steps:

- Check the front arm side play **A** by moving it from side to side.  
If side play is noticeable, check the bushings.
- Check the front arm vertical movement **B** by moving it up and down.  
If the vertical movement is tight or rough, or if there is binding, check the bushings.

\*\*\*\*\*

2. Remove:

- Front arms

## CHECKING THE FRONT ARM

1. Check:

- Front arms **1**  
Bends/damage → Replace.

2. Check:

- Bushings **2**  
Wear/damage → Replace.

## CHECKING THE FRONT SHOCK ABSORBER

1. Check:

- Shock absorber rod  
Bends/damage → Replace the shock absorber assembly.
- Shock absorber assembly  
Oil leaks → Replace the shock absorber assembly.
- Spring  
Fatigue → Replace the shock absorber assembly.  
Move the spring up and down.

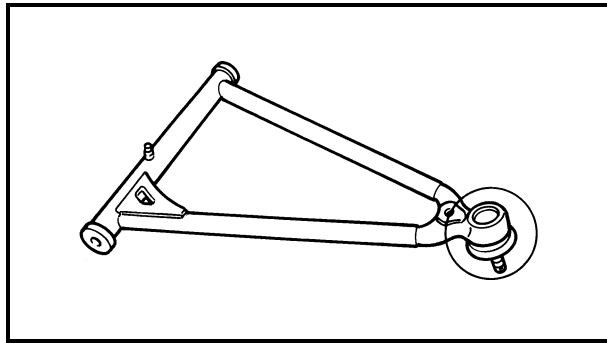

## CHECKING THE BALL JOINT

1. Check:

- Ball joint (front arm-upper)  
Damage/pitting → Replace the front arm (upper).  
Free play → Replace the front arm.  
Turns roughly → Replace the front arm (upper).

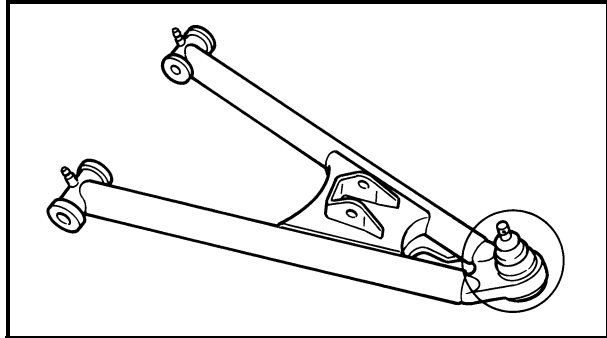

2. Check:

- Ball joint (front arm-lower)  
Damage/pitting → Replace the ball joint.  
Free play → Replace the ball joint.  
Turns roughly → Replace the ball joint.

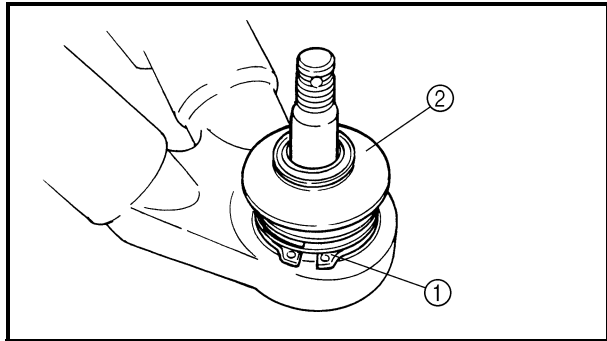

\*\*\*\*\*

### Ball joint replacement steps:

- Clean the outside of the front lower arm.
- Remove the circlip ① and rubber boot ②.  
Use the ball joint remover and installer set.

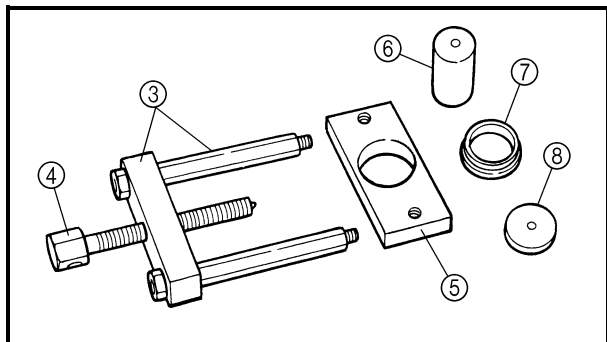

**Ball joint remover/installer set:**  
P/N. YM-01474, 90890-01474  
**Ball joint remover/installer attachment set:**  
P/N. YM-01480, 90890-01480

③ Body	YM-01474
④ Long bolt	90890-01474
⑤ Base	YM-01480 90890-01480
⑥ Remover attachment	
⑦ Installer spacer	
⑧ Installer washer	

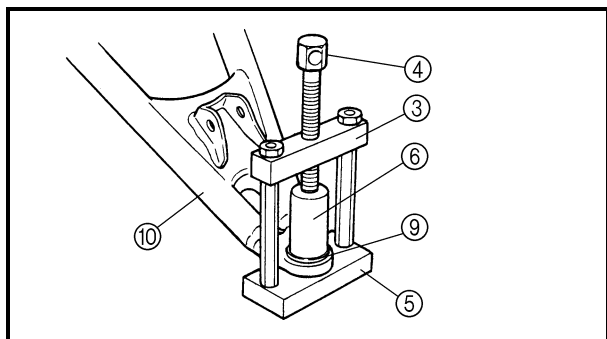

- Install the body ③, long bolt ④, base ⑤ and attachment ⑥ onto ball joint.
- Hold the body ③ in place while turning in the long bolt ④ to remove the ball joint ⑨ from the front lower arm ⑩.
- Remove the ball joint remover/installer.



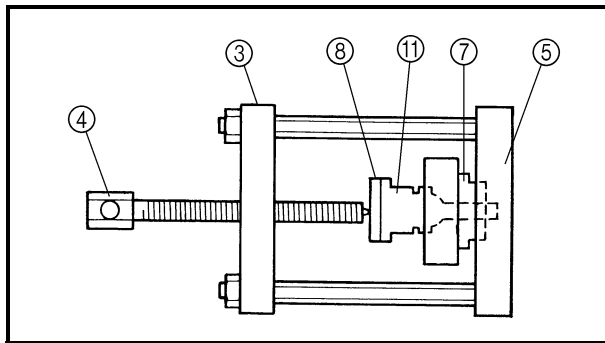

- Attach the assembled ball joint remover/installer, new ball joint ⑪, installer spacer ⑦ and installer washer ⑧ to the front lower arm ⑩.

**NOTE:** \_\_\_\_\_

- Do not tap or damage the top of the ball joint.
- Installer spacer ⑦ must be aligned with the projection on the head of the ball joint ⑪.

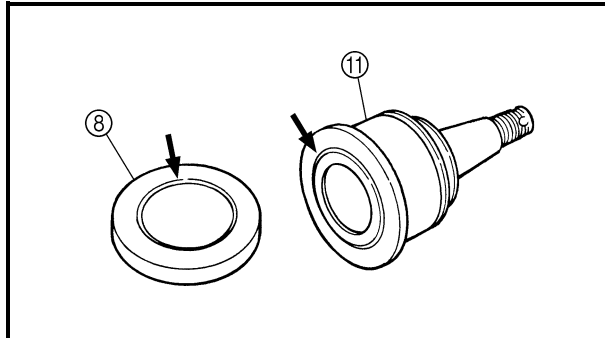

- Remove the ball joint remover/installer.
- Apply lithium-soap base grease to the new ball joint ⑪.
- Install a new rubber boot and new circlip.

**NOTE:** \_\_\_\_\_

Always use a new ball joint set.

\*\*\*\*\*

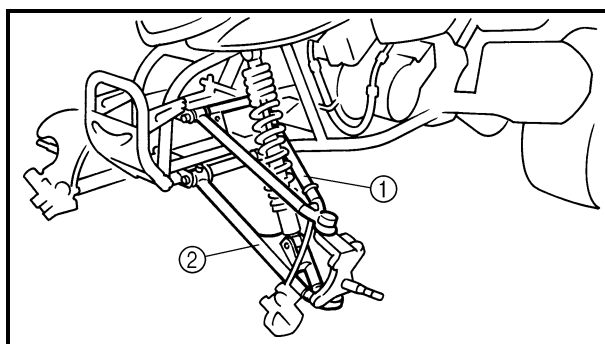
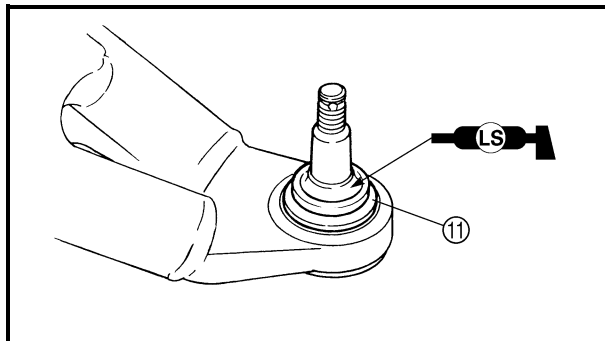

## INSTALLING THE FRONT ARM

1. Install:

- Front upper arm ①

38 Nm (3.8 m • kg, 27 ft • lb)

- Front lower arm ②

32 Nm (3.2 m • kg, 23 ft • lb)

**NOTE:** \_\_\_\_\_

Be sure to position the bolts (upper and lower) so that the bolt head faces outward.



REAR SHOCK ABSORBER AND RELAY ARM

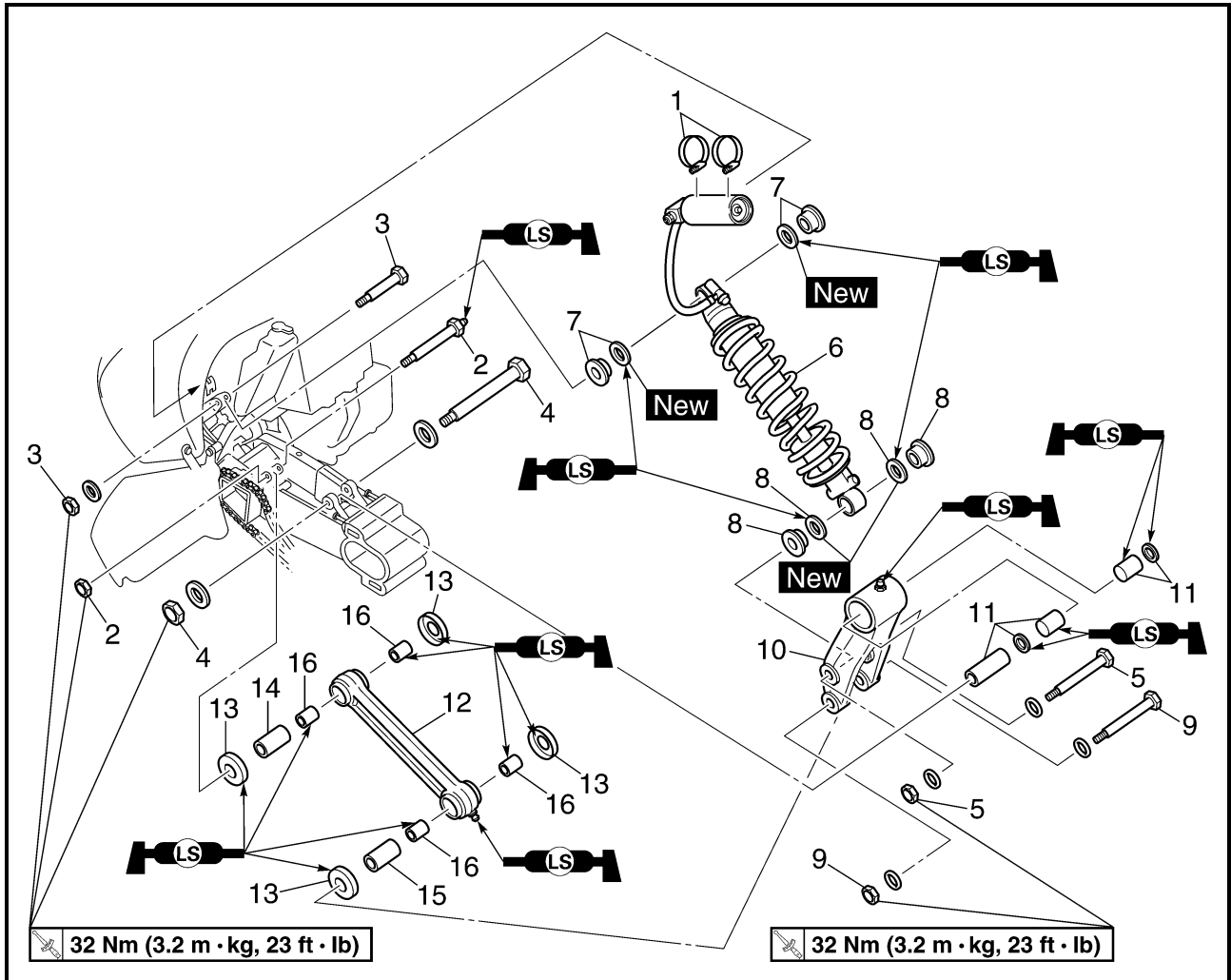

Order	Job name/Part name	Q'ty	Remarks
	<b>Removing the rear shock absorber and relay arm</b>		Remove the parts in the order below.
	Rear wheels and hub		Refer to "REAR WHEELS, WHEEL AXLE AND HUB".
1	Metal screw clamp	2	Refer to "REMOVING THE REAR SHOCK ABSORBER".
2	Self-locking nut/bolt	1/1	
3	Self-locking nut/bolt	1/1	
4	Self-locking nut/bolt	1/1	
5	Self-locking nut/bolt	1/1	
6	Rear shock absorber	1	
7	Collar/oil seal	2/2	
8	Collar/oil seal	2/2	

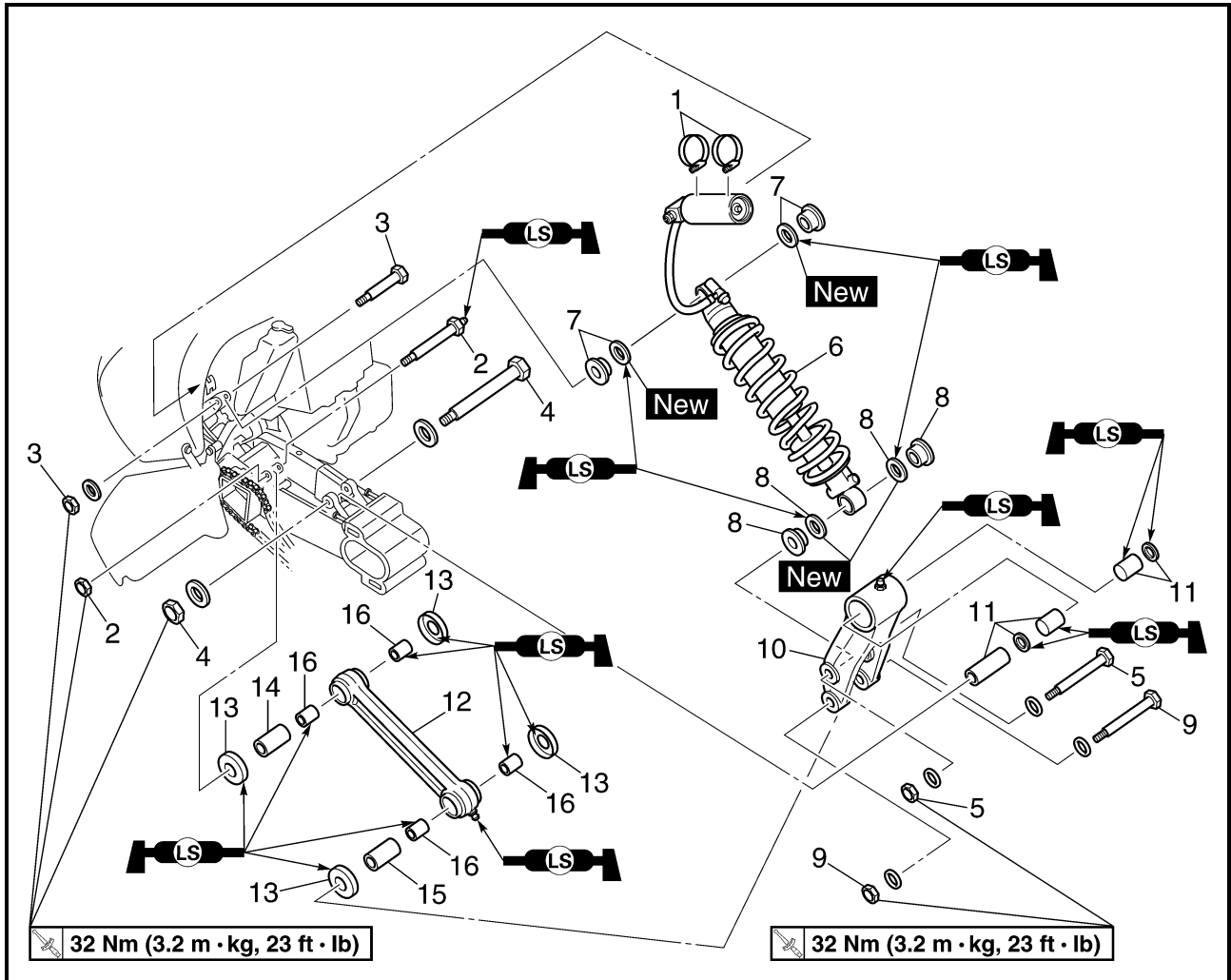

Order	Job name/Part name	Q'ty	Remarks
9	Self-locking nut/bolt	1/1	Refer to "INSTALLING THE RELAY ARM AND CONNECTING ARM".
10	Relay arm	1	
11	Spacer/oil seal/bushing	1/2/2	
12	Connecting arm	1	
13	Dust cover	4	
14	Spacer	1	
15	Spacer	1	
16	Bushing	4	Refer to "INSTALLING THE RELAY ARM AND CONNECTING ARM". For installation, reverse the removal procedure.



## HANDLING THE REAR SHOCK ABSORBER AND GAS CYLINDER

### **⚠ WARNING**

This rear shock absorber and gas cylinder contain highly compressed nitrogen gas. Before handling the rear shock absorber or gas cylinder, read and make sure you understand the following information. The manufacturer cannot be held responsible for property damage or personal injury that may result from improper handling of the rear shock absorber and gas cylinder.

- Do not tamper or attempt to open the rear shock absorber or gas cylinder.
- Do not subject the rear shock absorber or gas cylinder to an open flame or any other source of high heat. High heat can cause an explosion due to excessive gas pressure.
- Do not deform or damage the rear shock absorber or gas cylinder in any way. If the rear shock absorber, gas cylinder or both are damaged, damping performance will suffer.

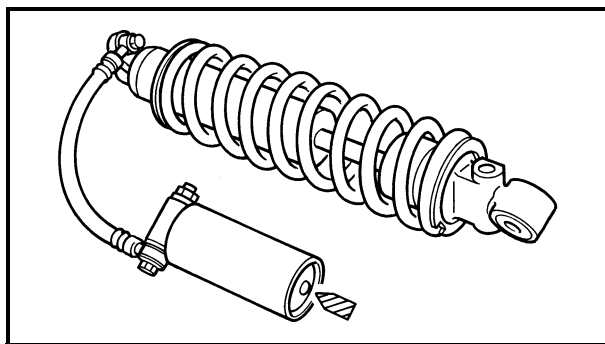

### DISPOSING OF A REAR SHOCK ABSORBER AND GAS CYLINDER

Gas pressure must be released before disposing of a rear shock absorber and gas cylinder. To release the gas pressure, press on the gas valve needle with a suitable tool as shown, until all of the gas is released (the hissing has stopped).

### **⚠ WARNING**

Wear eye protection to prevent eye damage from released gas or metal chips.



## REMOVING THE REAR SHOCK ABSORBER

1. Remove:

- Connecting arm-to-frame bolt
- Rear shock absorber upper bolt

**NOTE:** \_\_\_\_\_

While removing the connecting arm-to-frame bolt, hold the swingarm so that it does not drop down.

---

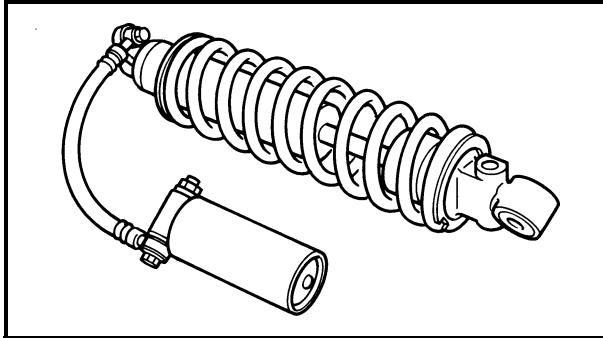

## CHECKING THE REAR SHOCK ABSORBER

1. Check:

- Shock absorber  
Oil leaks → Replace the rear shock absorber assembly.
- Shock absorber rod  
Bends/damage → Replace the rear shock absorber assembly.
- Spring  
Fatigue → Replace the rear shock absorber assembly.  
Move the spring up and down.
- Gas cylinder  
Damage/gas leaks → Replace the rear shock absorber assembly.

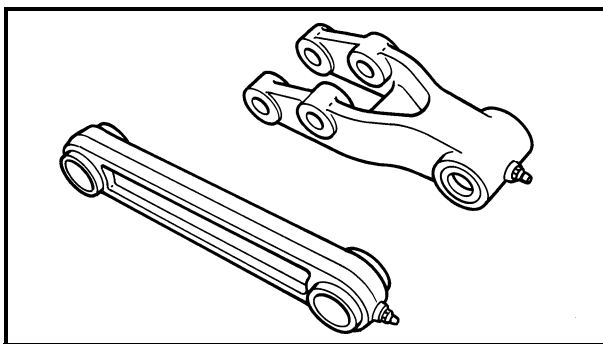

## CHECKING THE RELAY ARM AND CONNECTING ARM

1. Check:

- Relay arm
- Connecting arm  
Damage/wear → Replace.
- Bushings
- Spacers
- Oil seals  
Damage/pitting/scratches → Replace.

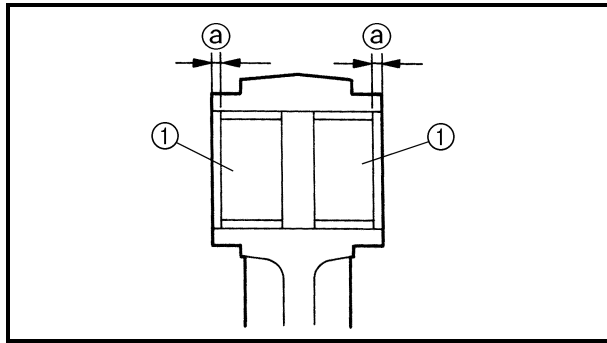

## INSTALLING THE RELAY ARM AND CONNECTING ARM

1. Install:

- Bushing ①  
(to connecting arm)

**NOTE:**

Apply the lithium soap base grease on the bushing when installing.



**Installed depth of bushing ①:**  
**1 mm (0.04 in)**

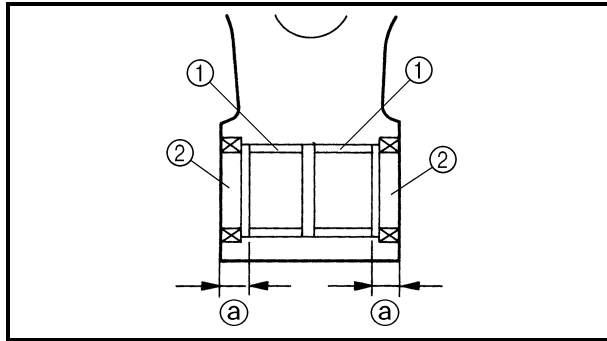

2. Install:

- Bushing ①
- Oil seal ② **New**  
(to relay arm)

**NOTE:**

Apply the lithium soap base grease on the bushing when installing.



**Installed depth of bushing ①:**  
**6.5 mm (0.26 in)**

## INSTALLING THE REAR SHOCK ABSORBER

1. Install:

- Connecting arm
- Relay arm
- Rear shock absorber

**NOTE:**

When installing the rear shock absorber, lift up the swingarm.

SWINGARM AND DRIVE CHAIN

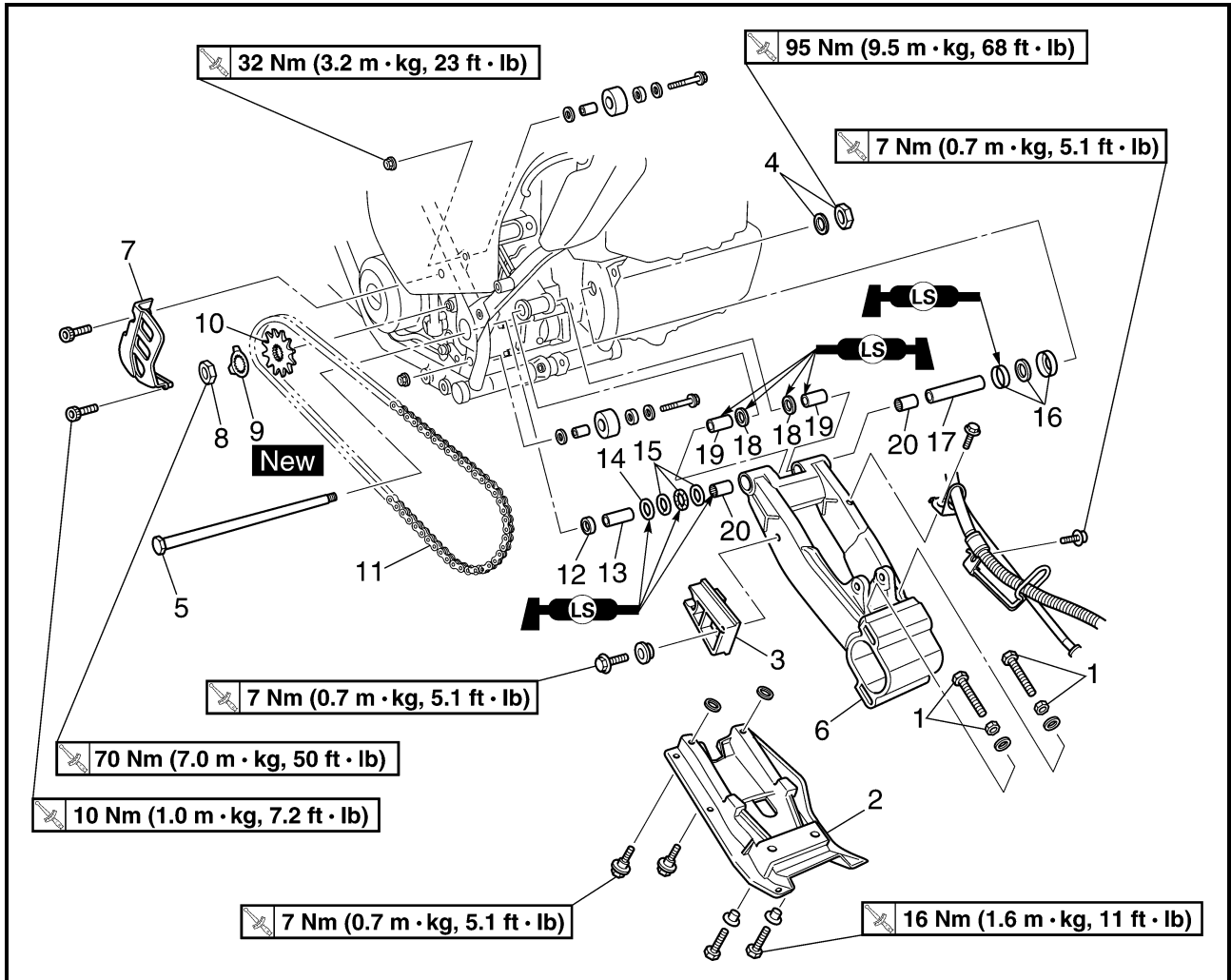

Order	Job name/Part name	Q'ty	Remarks
	<b>Removing the swingarm and drive chain</b>		Remove the parts in the order below.
	Rear wheels and hub		Refer to "REAR WHEELS, WHEEL AXLE AND HUB".
	Rear shock absorber		Refer to "REAR SHOCK ABSORBER AND RELAY ARM".
	Left footrest and left footrest guard bracket		Refer to "ENGINE REMOVAL" in CHAPTER 5.
1	Adjusting bolt/nut	2/2	
2	Swingarm skid plate	1	
3	Drive chain guide	1	
4	Pivot shaft nut/washer	1/1	
5	Pivot shaft	1	
6	Swingarm	1	Refer to "REMOVING THE SWINGARM".
7	Drive sprocket cover	1	

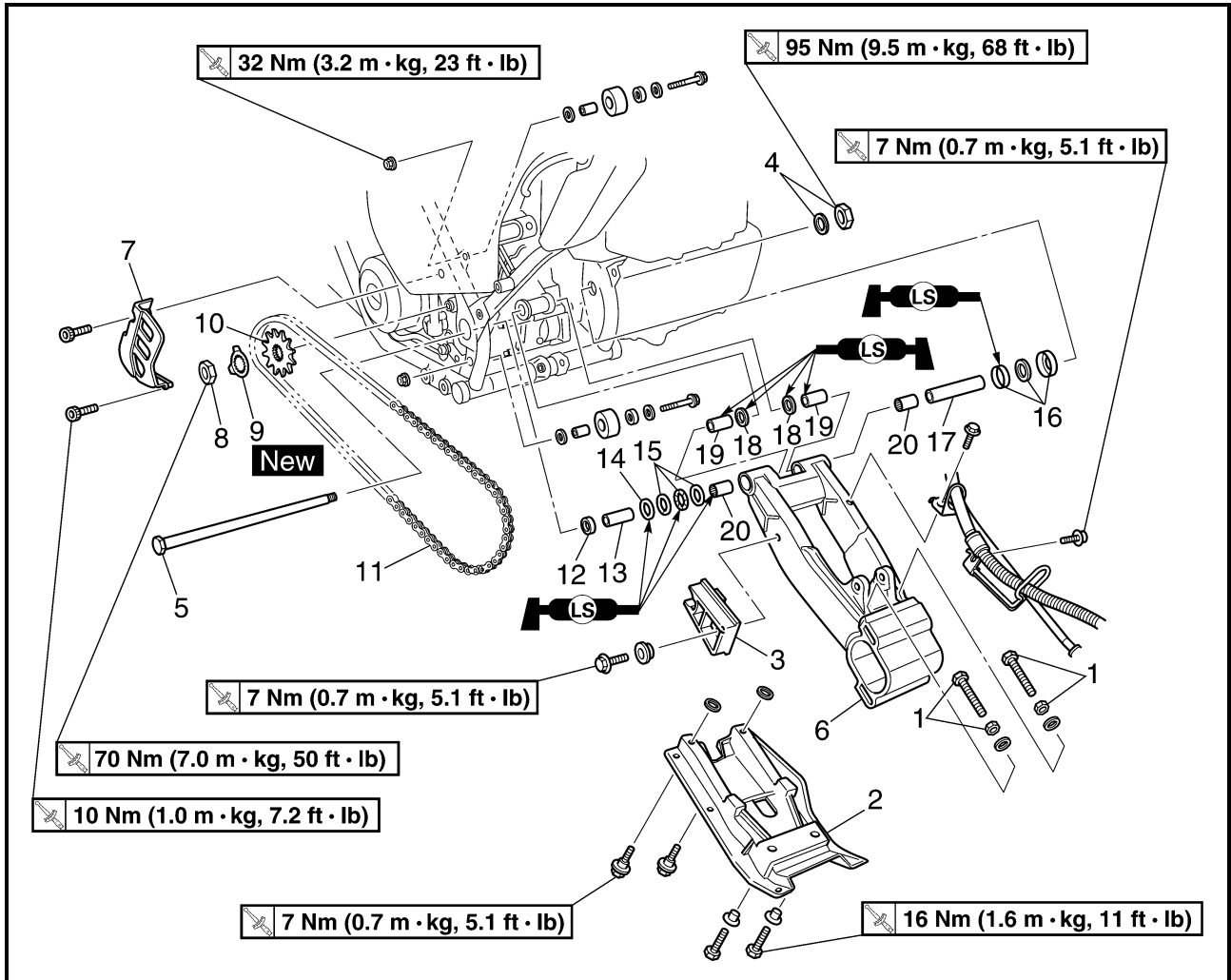

Order	Job name/Part name	Q'ty	Remarks
8	Nut	1	Refer to "INSTALLING THE DRIVE SPROCKET".
9	Lock washer	1	
10	Drive sprocket	1	
11	Drive chain	1	
12	Collar	1	
13	Spacer	1	Refer to "INSTALLING THE SWING-ARM". For installation, reverse the removal procedure.
14	Oil seal	1	
15	Bearing	1	
16	Dust cover/oil seal/washer	1/1/1	
17	Spacer	1	
18	Oil seal	2	
19	Bushing	2	
20	Bearing	2	





**NOTE:**

Before removing the drive chain and the sprockets, measure the drive chain slack and a ten link section of the drive chain.

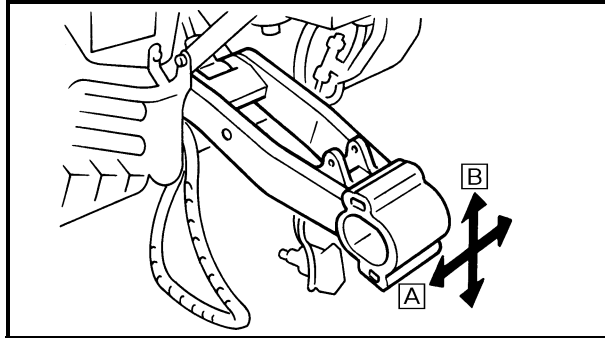

**REMOVING THE SWINGARM**

1. Check:

- Swingarm free play

\*\*\*\*\*

**Checking steps:**

- Check the tightening torque of the pivot shaft nut.

	<p><b>Pivot shaft nut:</b>  <b>95 Nm (9.5 m • kg, 68 ft • lb)</b></p>
---	---

- Check the swingarm side play **A** by moving it from side to side.

If side play is noticeable, check the collar, spacers, bearings, bushings and frame pivot.

- Check the swingarm vertical movement **B** by moving it up and down.

If vertical movement is tight or rough, or if there is binding, check the collar, spacers, bearings, bushings and frame pivot.

\*\*\*\*\*

2. Remove:

- Pivot shaft nut
- Pivot shaft
- Swingarm

**CHECKING THE SWINGARM**

1. Check:

- Swingarm  
 Bends/cracks/damage → Replace.

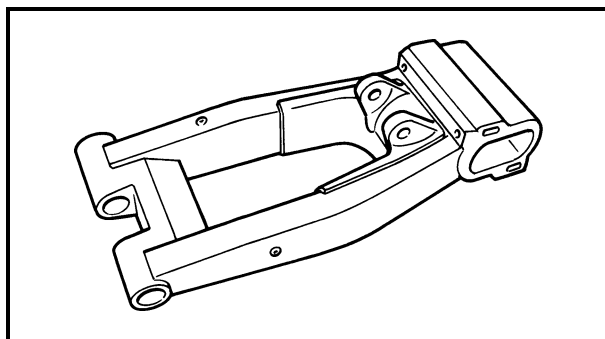

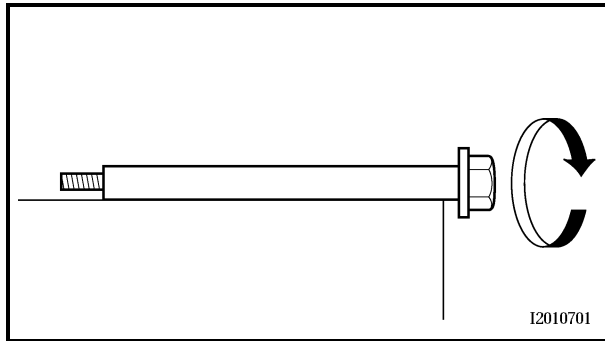

## 2. Check:

- Pivot shaft
  - Roll the axle on a flat surface.
  - Bends → Replace.

### **⚠ WARNING**

**Do not attempt to straighten a bent pivot shaft.**

## 3. Clean:

- Pivot shaft
- Collar
- Spacers
- Bearings
- Bushings



**Recommended cleaning solvent:  
Kerosine**

## 4. Check:

- Spacers
  - Damage/wear → Replace.
- Bearings
- Bushings
  - Damage/pitting → Replace.

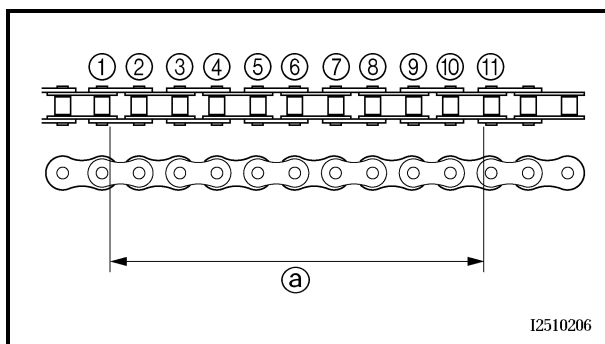

## CHECKING THE DRIVE CHAIN

### 1. Measure:

- Ten-link section ① of the drive chain
  - Out of specification → Replace the drive chain.



**Max. ten-link drive chain section:  
150.1 mm (5.91 in)**

### NOTE:

- While measuring the ten-link section, push down on the drive chain to increase its tension.
- Measure the length between drive chain roller ① and ⑪ as shown.
- Perform this measurement at two or three different places.

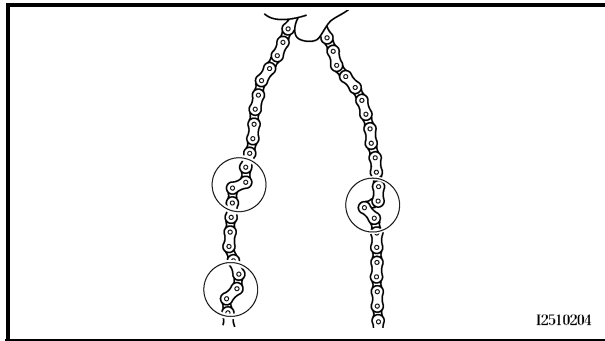

2. Check:

- Drive chain  
Stiffness → Clean and lubricate or replace.

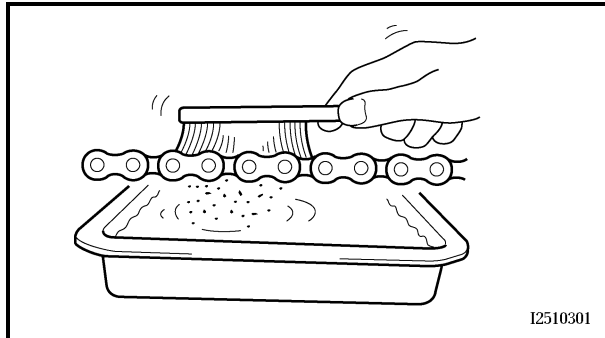

3. Clean:

- Drive chain

\*\*\*\*\*

- Wipe the drive chain with a clean cloth.
- Put the drive chain in kerosine and remove any remaining dirt.

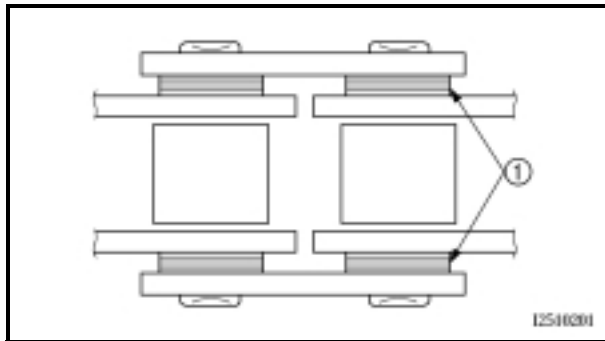

- Remove the drive chain from the kerosine and completely dry it.

**CAUTION:**

This machine has a drive chain with small rubber O-rings ① between the drive chain side plates. Never use high-pressure water or air, steam, gasoline, certain solvents (e.g., benzine), or a coarse brush to clean the drive chain. High-pressure methods could force dirt or water into the drive chain's internals, and solvents will deteriorate the O-rings. A coarse brush can also damage the O-rings. Therefore, use only kerosine to clean the drive chain.

\*\*\*\*\*

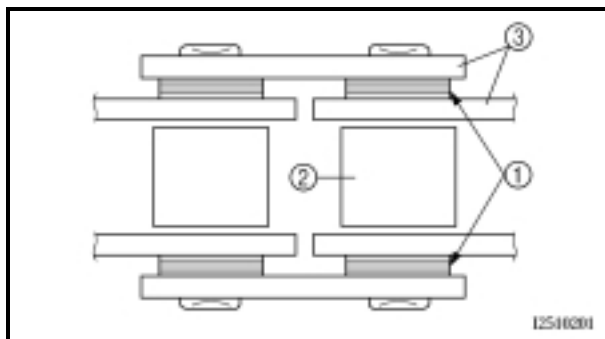

4. Check:

- O-rings ①  
Damage → Replace the drive chain.
- Drive chain rollers ②  
Damage/wear → Replace the drive chain.
- Drive chain side plates ③  
Cracks/damage/wear → Replace the drive chain.



## 5. Lubricate:

- Drive chain



**Recommended lubricant:**  
 Engine oil or chain lubricant  
 suitable for O-ring chains

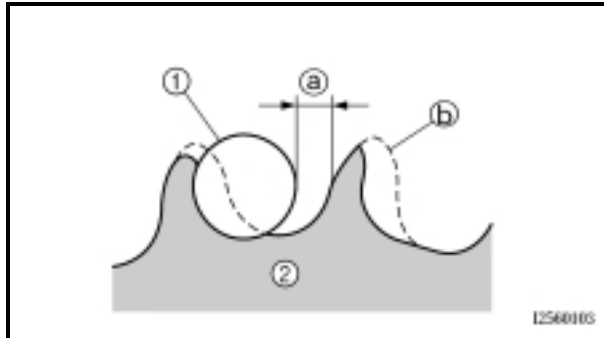

## 6. Check:

- Drive sprocket
- Driven sprocket

More than 1/4 tooth **a** wear → Replace the drive chain sprockets as a set.

Bent teeth → Replace the drive chain sprockets as a set.

- b** Correct
- 1** Drive chain roller
- 2** Drive chain sprocket

## INSTALLING THE SWINGARM

### 1. Install:

- Bearings **1**
- Bushings **2**  
 (to swingarm)

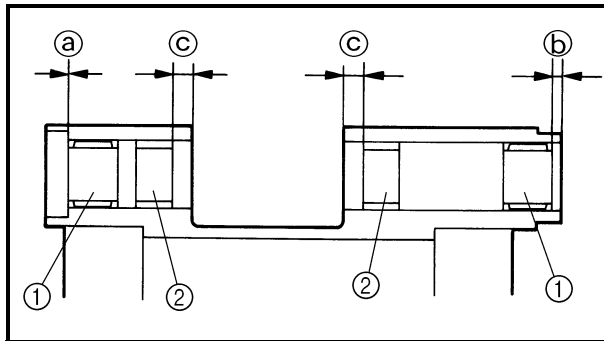

### NOTE:

Apply the lithium soap base grease on the bearing and bushing when installing.



**Installed depth of bearing:**  
 Left **a**: 0 mm (0 in)  
 Right **b**: 4 mm (0.16 in)  
**Installed depth of bushing **c**:**  
 8 mm (0.31 in)

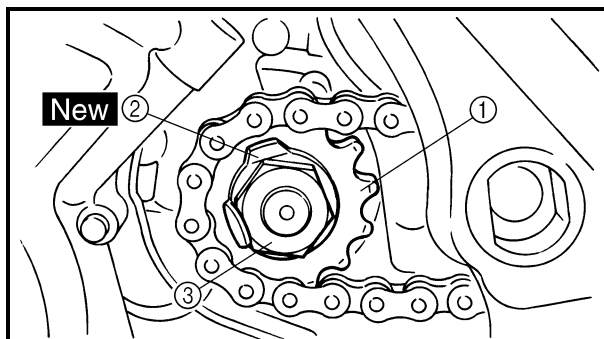

## INSTALLING THE DRIVE SPROCKET

### 1. Install:

- Drive sprocket **1**
- Lock washer **2** **New**
- Nut **3**

**70 Nm (7.0 m • kg, 50 ft • lb)**

2. Bend the lock washer tab along a flat side of the nut.



# ENGINE

## ENGINE REMOVAL MUFFLER AND EXHAUST PIPES

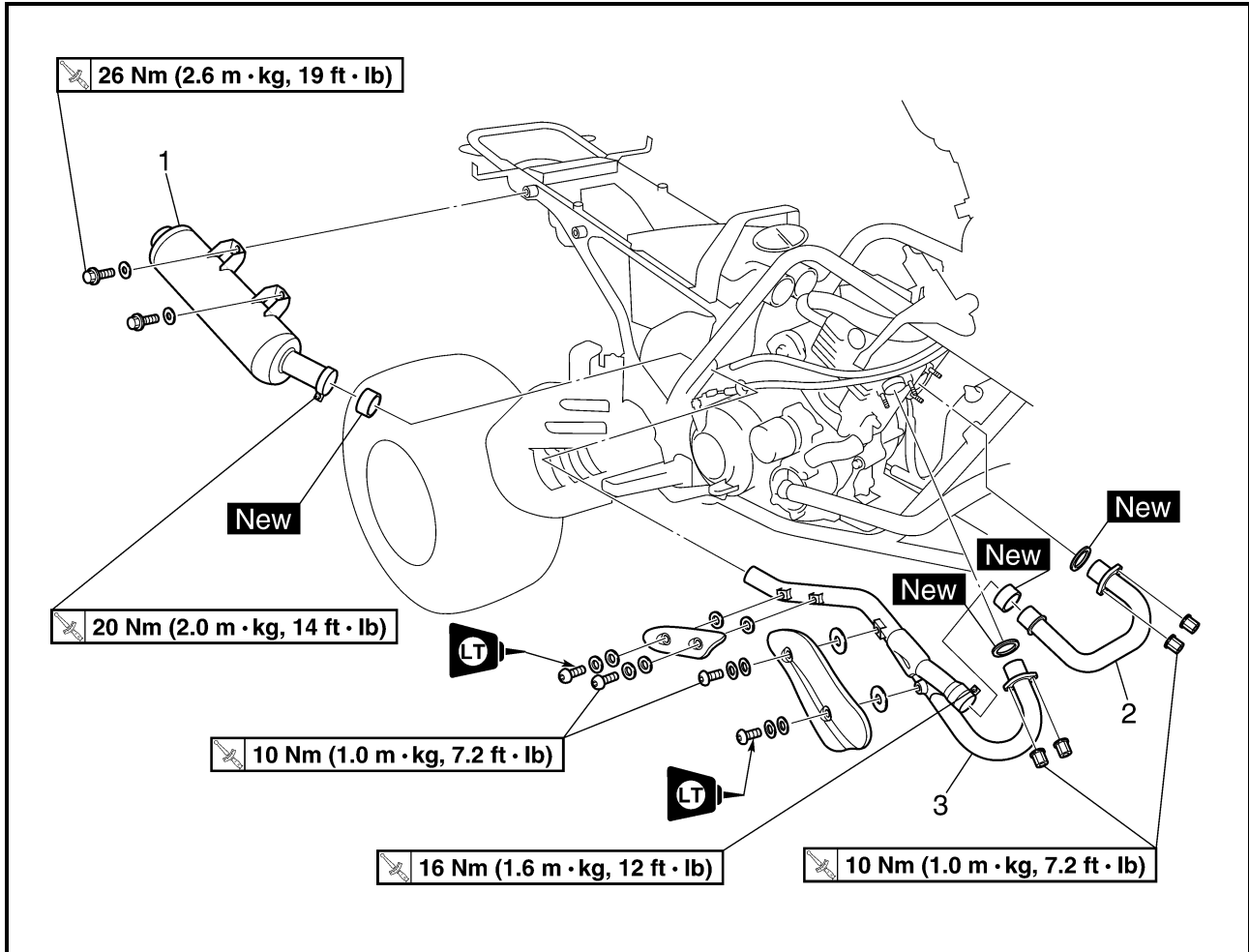

Order	Job name/Part name	Q'ty	Remarks
	<b>Removing the muffler and exhaust pipes</b>		Remove the parts in the order below.
	Seat/left footrest guard/engine Skid plate		Refer to "SEAT, FENDERS AND FUEL TANK" in CHAPTER 3.
	Front and rear fenders		
	Fuel tank and rubber covers		
1	Muffler	1	For installation, reverse the removal procedure.
2	Exhaust pipe 1	1	
3	Exhaust pipe 2	1	



LEFT FOOTREST

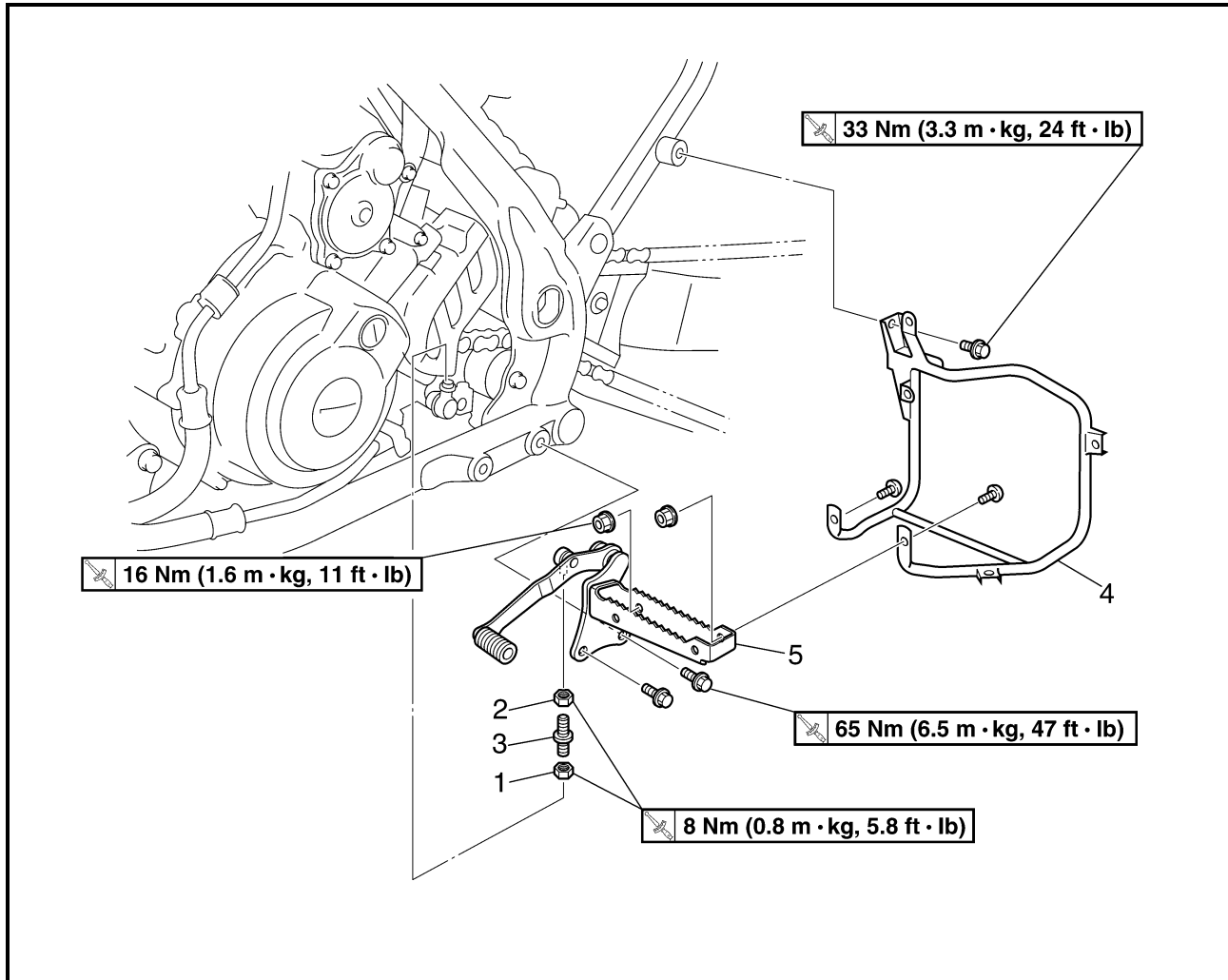

Order	Job name/Part name	Q'ty	Remarks
	<b>Removing the left footrest</b>		Remove the parts in the order below.
1	Locknut	1	
2	Locknut	1	Left-hand threads
3	Adjusting rod	1	
4	Left footrest guard bracket	1	
5	Left footrest	1	
			For installation, reverse the removal procedure.



LEADS, CABLES AND HOSES

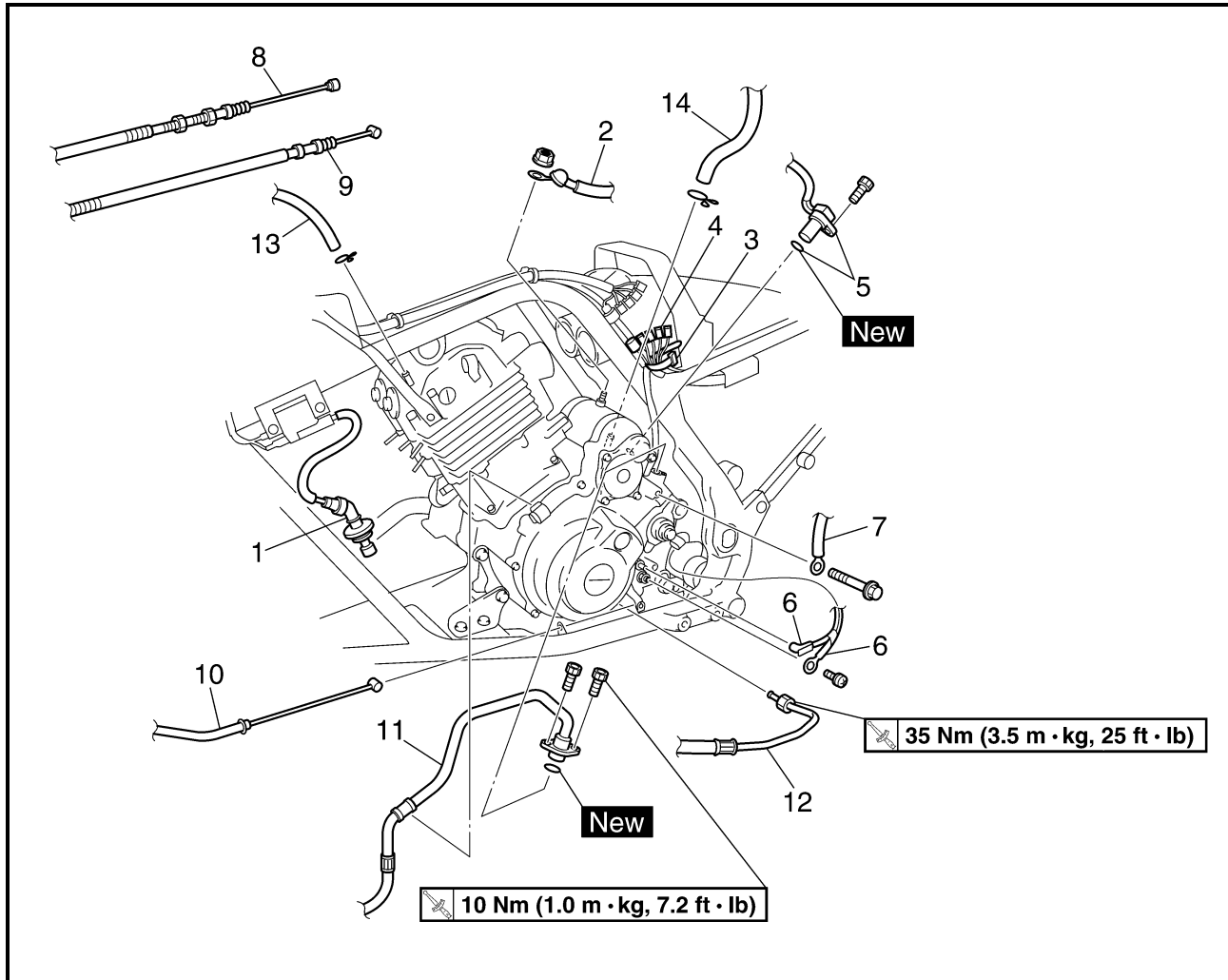

Order	Job name/Part name	Q'ty	Remarks
	<b>Removing the leads, cables and hoses</b>		Remove the parts in the order below.
	Engine oil		Drain.
	Coolant		Drain.
	Water jacket outlet pipe		Refer to "THERMOSTAT" in CHAPTER 6.
	Radiator outlet hose		Refer to "WATER PUMP" in CHAPTER 6.
	Carburetors		Refer to "CARBURETORS" in CHAPTER 7.
	Rear shock absorber and connecting arm		Refer to "REAR SHOCK ABSORBER AND RELAY ARM" in CHAPTER 4.
	Drive sprocket and swingarm		Refer to "SWINGARM AND DRIVE CHAIN" in CHAPTER 4.
1	Spark plug cap	1	
2	Starter motor lead	1	
3	Band	1	

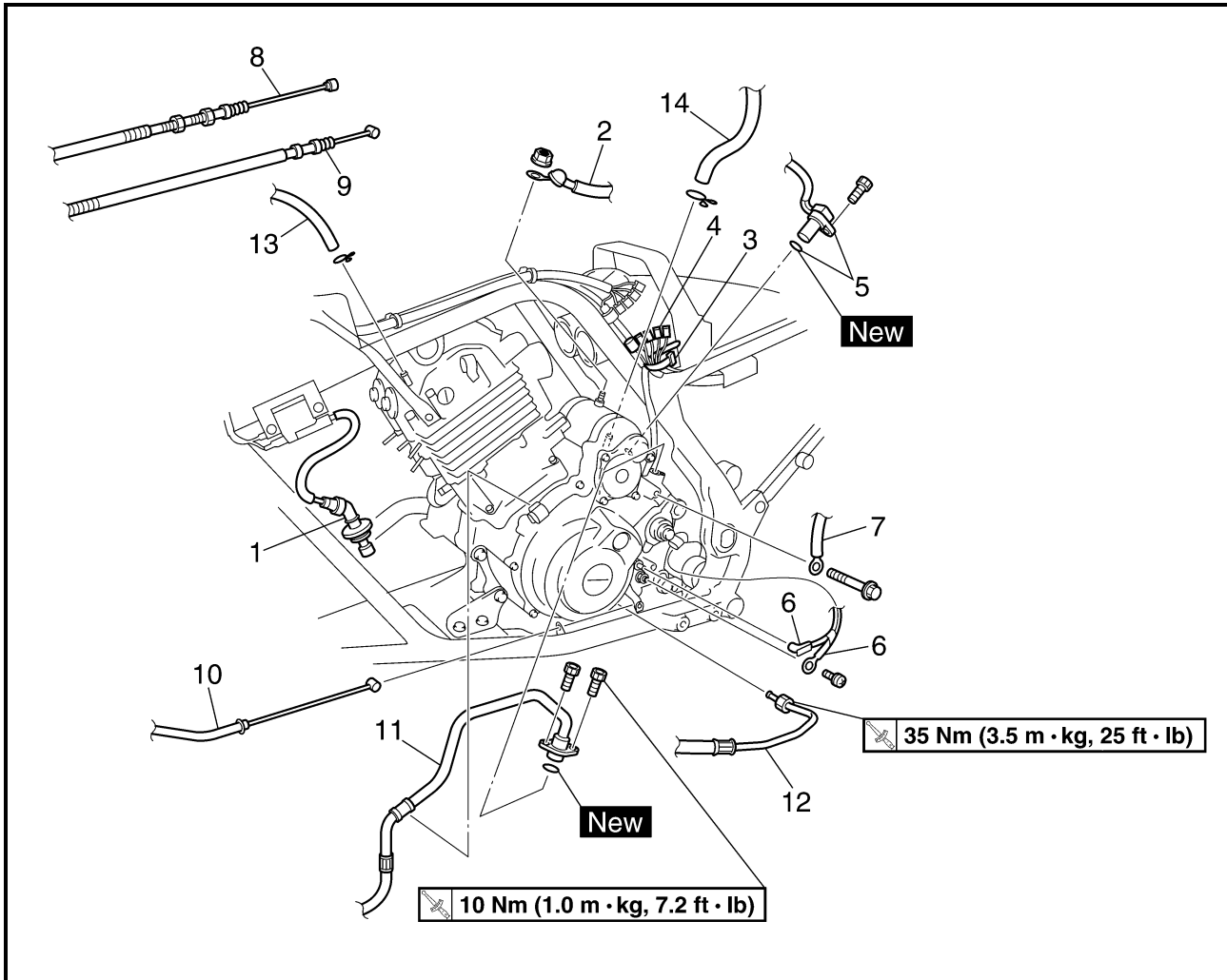

Order	Job name/Part name	Q'ty	Remarks
4	Coupler	5	Disconnect.
5	Speed sensor/O-ring	1/1	
6	Neutral switch lead/reverse switch lead	1/1	
7	Ground lead	1	
8	Clutch cable	1	
9	Parking brake cable	1	
10	Reverse control cable	1	
11	Oil pipe 2	1	Disconnect.
12	Oil pipe 1	1	Disconnect.
13	Oil tank breather hose	1	Disconnect.
14	Crankcase breather hose	1	Disconnect.
			For installation, reverse the removal procedure.





ENGINE MOUNTING BOLTS

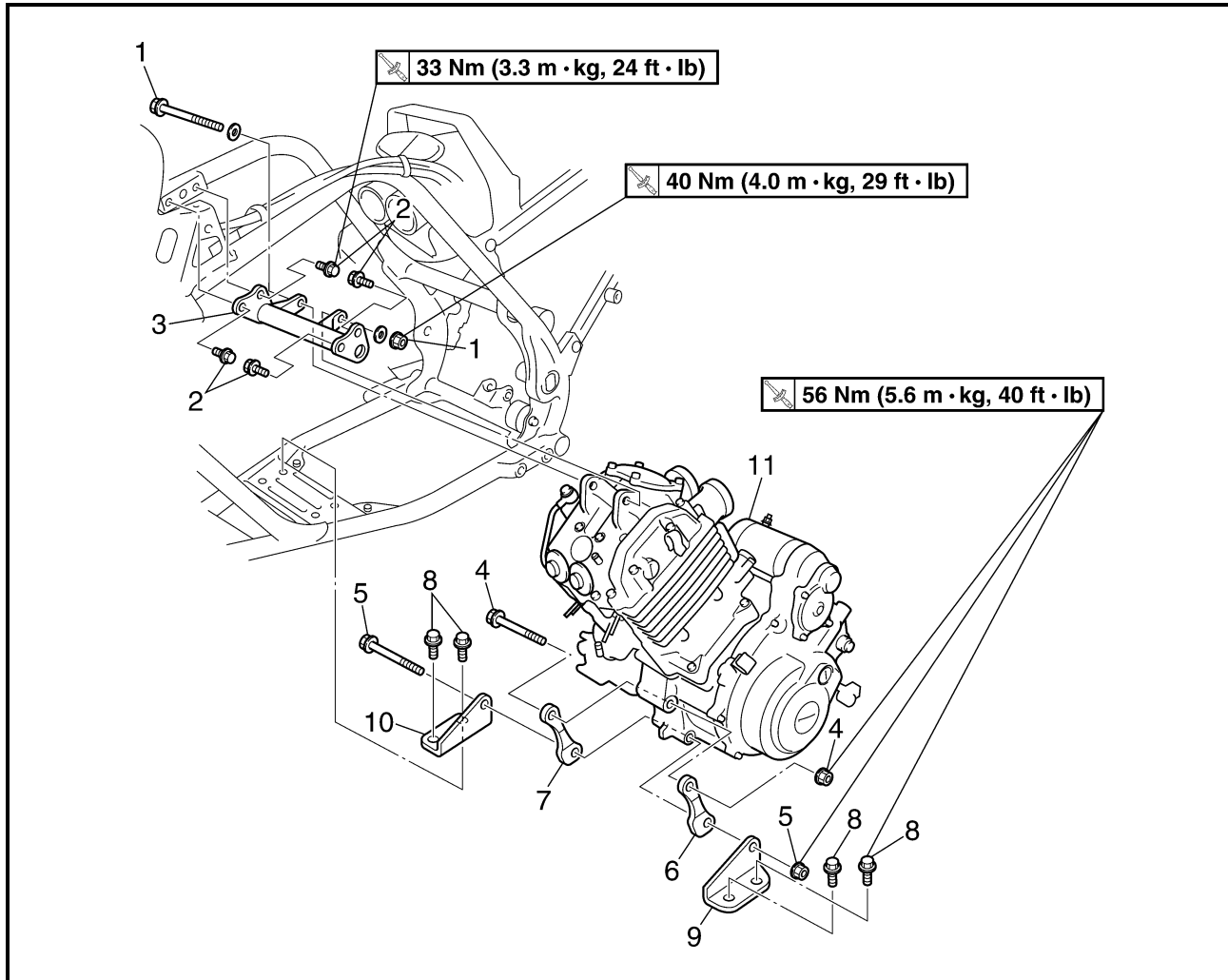

Order	Job name/Part name	Q'ty	Remarks
	<b>Removing the engine mounting bolt</b>		Remove the parts in the order below.
1	Engine mounting bolt (upper)/nut	1/1	<p><b>CAUTION:</b> _____</p> <p><b>Install all of the bolts/nuts and then tighten them to full torque specifications.</b></p> <p>Refer to "INSTALLING THE ENGINE".</p>
2	Engine bracket bolt (upper)	4	
3	Engine bracket (upper)	1	
4	Engine mounting bolt (middle)/nut	1/1	
5	Engine mounting bolt (lower)/nut	1/1	
6	Engine bracket (middle-left)	1	
7	Engine bracket (middle-right)	1	
8	Engine bracket bolt (lower)	4	
9	Engine bracket (lower-left)	1	
10	Engine bracket (lower-right)	1	

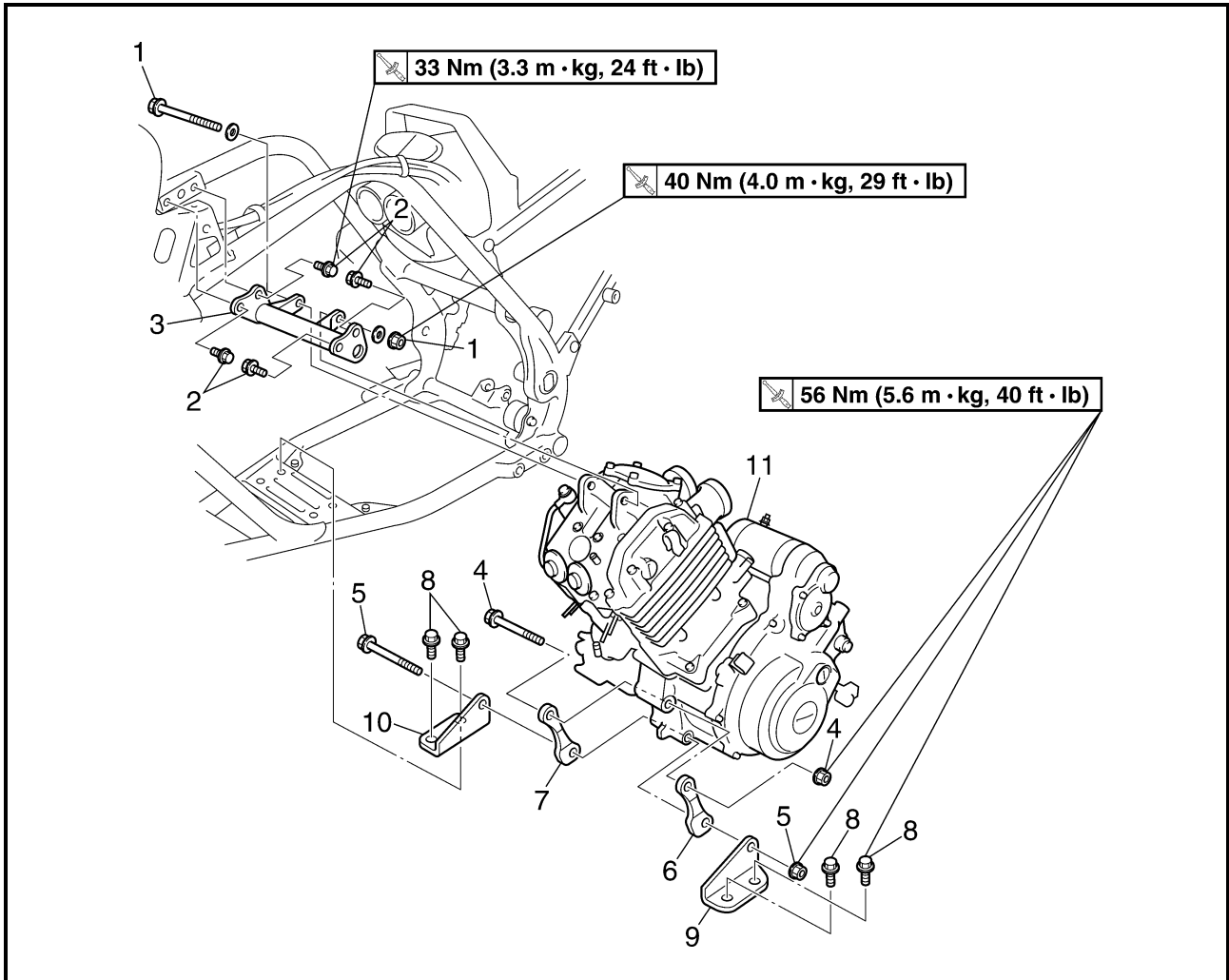

Order	Job name/Part name	Q'ty	Remarks
11	Engine assembly	1	<p><b>NOTE:</b> _____                      Remove the engine assembly from the left side of the machine.</p> <p>_____</p> <p>For installation, reverse the removal procedure.</p>

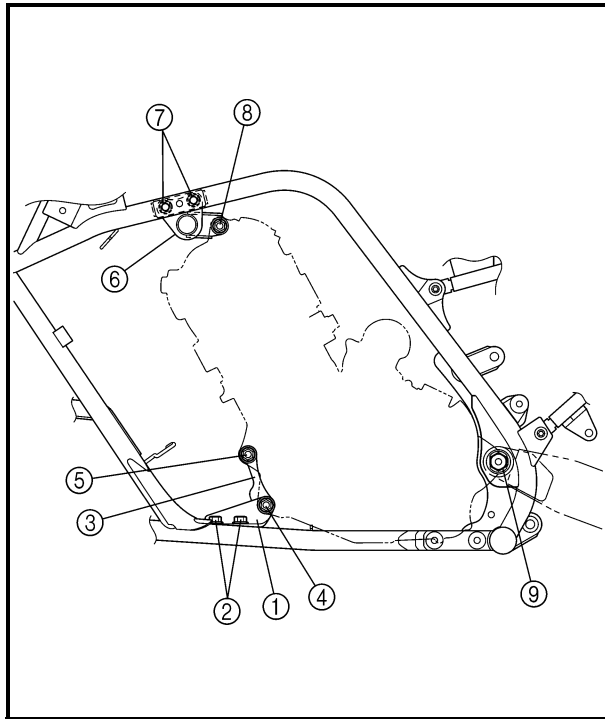

## INSTALLING THE ENGINE

### 1. Install:

- Engine brackets (lower) ①
- Engine bracket bolts (lower) ②
- Engine brackets (middle) ③
- Engine mounting bolt (lower)/nut ④
- Engine mounting bolt (middle)/nut ⑤
- Engine bracket (upper) ⑥
- Engine bracket bolts (upper) ⑦
- Engine mounting bolt (upper)/nut ⑧

### NOTE:

Do not fully tighten the bolts and nuts.

### 2. Install:

- Swingarm
- Pivot shaft/nut ⑨

### NOTE:

Do not fully tighten the pivot shaft nut.

### 3. Tighten:

- Engine bracket bolt (lower) ②

 **56 Nm (5.6 m • kg, 40 ft • lb)**

- Engine bracket bolt (upper) ⑦

 **33 Nm (3.3 m • kg, 24 ft • lb)**

- Engine mounting bolt (lower)/nut ④

 **56 Nm (5.6 m • kg, 40 ft • lb)**

- Engine mounting bolt (middle)/nut ⑤

 **56 Nm (5.6 m • kg, 40 ft • lb)**

- Engine mounting bolt (upper)/nut ⑧

 **40 Nm (4.0 m • kg, 29 ft • lb)**

- Pivot shaft/nut ⑨

 **95 Nm (9.5 m • kg, 68 ft • lb)**



CYLINDER HEAD COVER

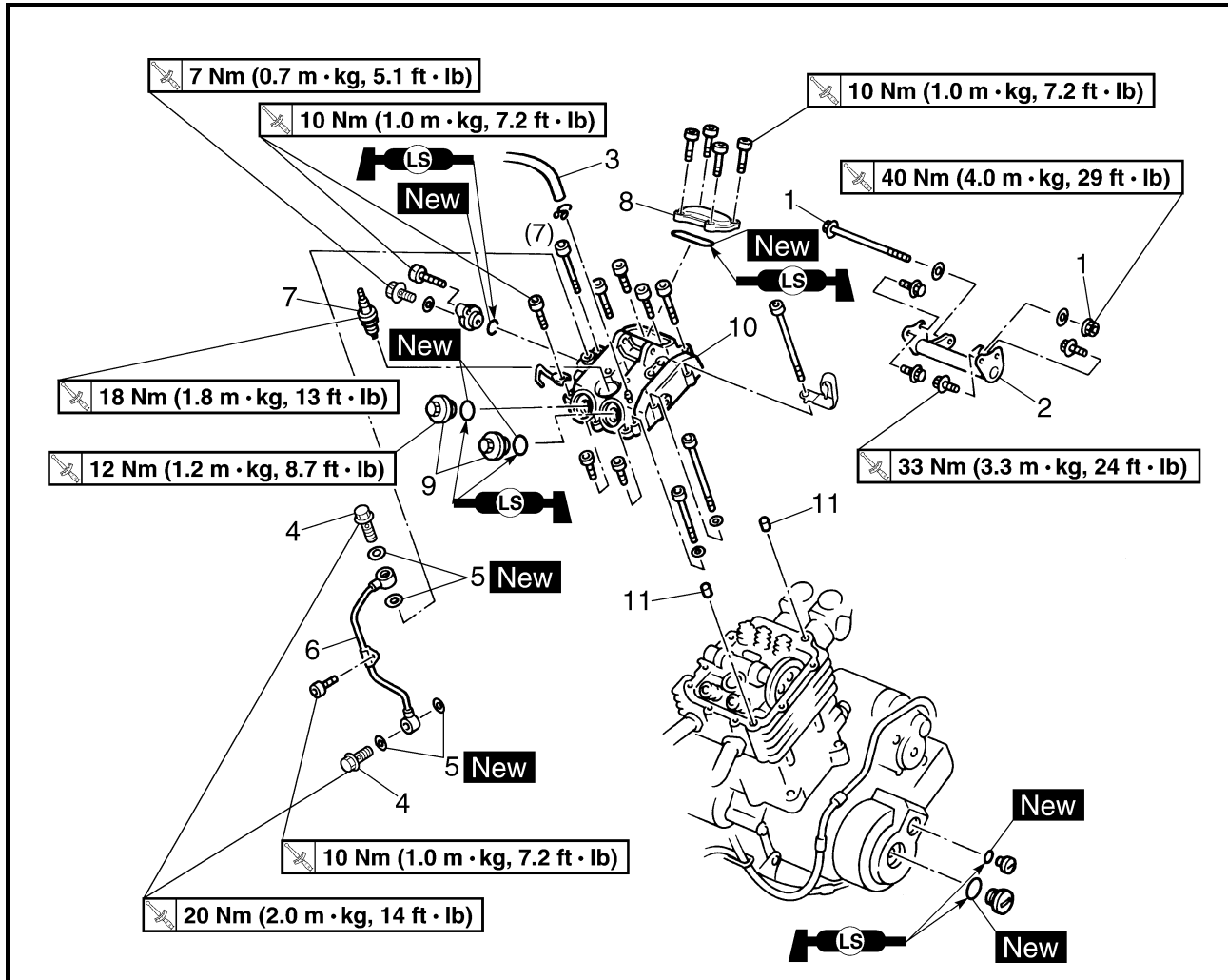

Order	Job name/Part name	Q'ty	Remarks
	<b>Removing the cylinder head cover</b>		Remove the parts in the order below.
	Seat/front fender		Refer to "SEAT, FENDERS AND FUEL TANK" in CHAPTER 3.
	Fuel tank/rubber cover 2		
1	Engine mounting bolt/nut	1/1	
2	Engine bracket (front-upper)	1	
3	Oil tank breather hose	1	
4	Union bolt	2	
5	Copper washer	4	
6	Oil delivery pipe 1	1	
7	Spark plug	1	
8	Tappet cover (intake)	1	
9	Tappet cover (exhaust)	2	

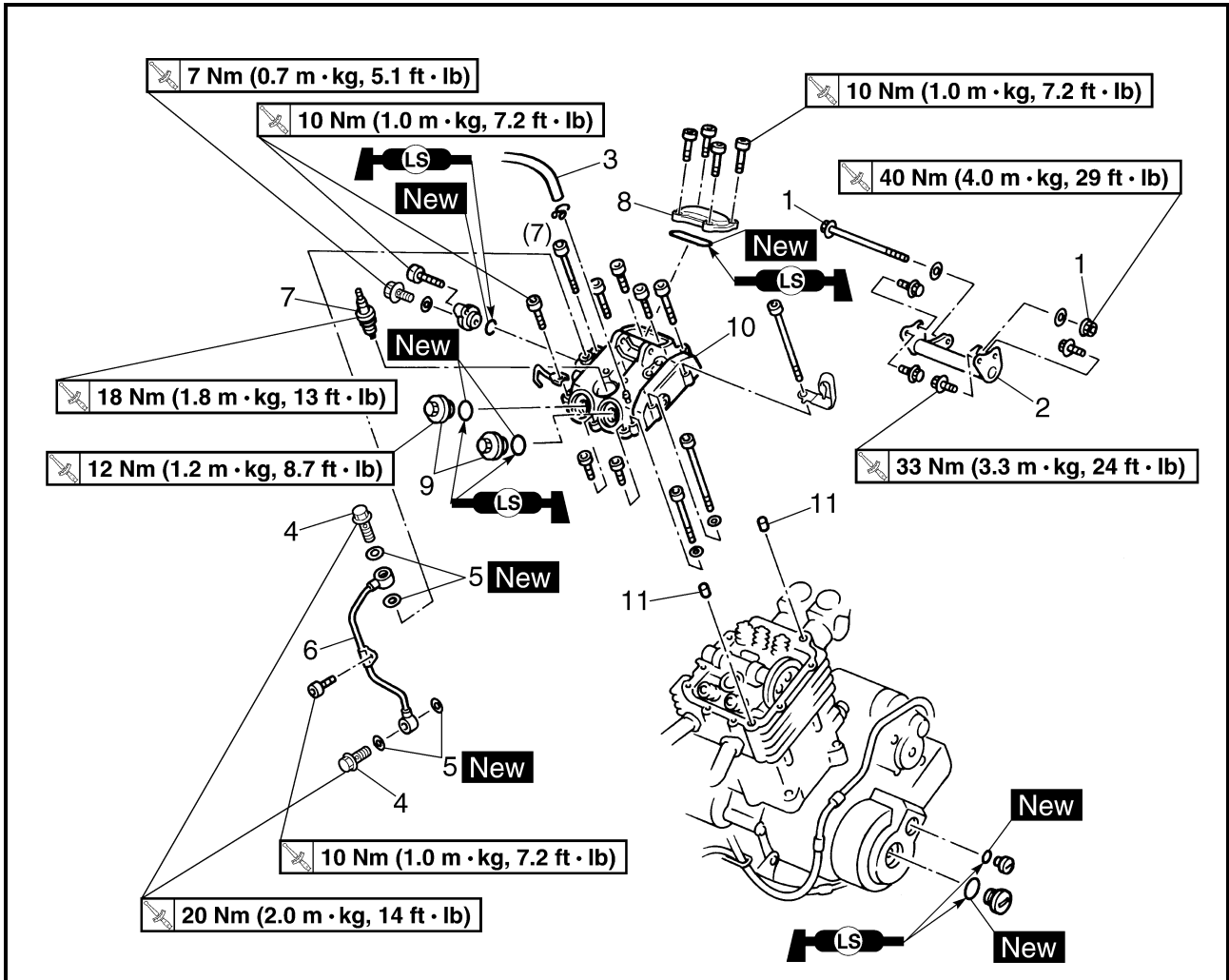

Order	Job name/Part name	Q'ty	Remarks
10	Cylinder head cover	1	Refer to "REMOVING/INSTALLING CYLINDER HEAD COVER".
11	Dowel pin	2	For installation, reverse the removal procedure.

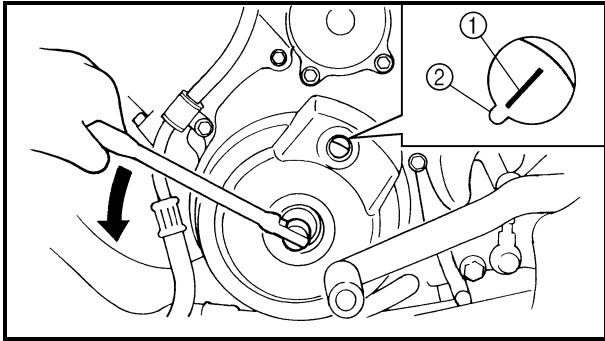

**REMOVING THE CYLINDER HEAD COVER**

1.Align:

- "1" mark  
(with stationary pointer)

\*\*\*\*\*

**Checking steps:**

- Turn the crankshaft counterclockwise with a wrench.
- Align the "1" mark ① on the rotor with the stationary pointer ② on the crankcase cover. When the "1" mark is aligned with the stationary pointer, the piston is at the Top Dead Center (T.D.C.).

**NOTE:** \_\_\_\_\_

- When the piston is at the top dead center (T.D.C.) on the compression stroke, there should be clearance between the valve stem tips and their respective rocker arm adjusting screws.
- If there is no clearance, rotate the crankshaft counterclockwise one turn.

\*\*\*\*\*

2.Remove:

- Cylinder head cover

**NOTE:** \_\_\_\_\_

Loosen each bolt 1/4 of a turn at a time, in stages and in a crisscross pattern. After all the bolts are loosened, remove them.

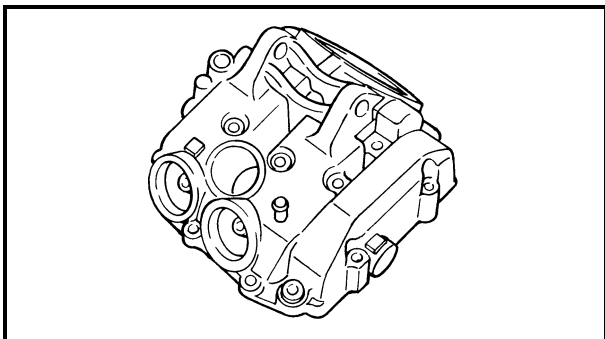

**CHECKING THE CYLINDER HEAD COVER**

1.Check:

- Cylinder head cover  
Cracks/damage → Replace the cylinder head cover and cylinder head as a set.

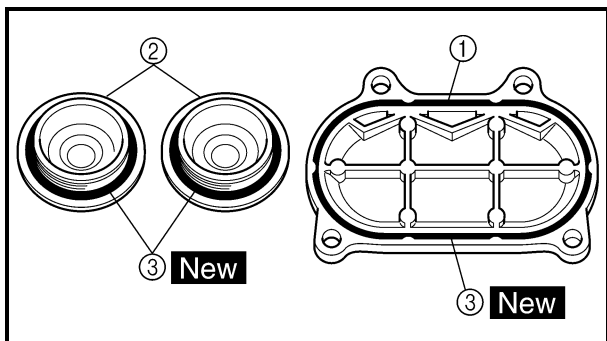

### CHECKING THE TAPPET COVER

1. Check:

- Tappet cover (intake) ①
- Tappet cover (exhaust) ②
- O-ring ③ **New**

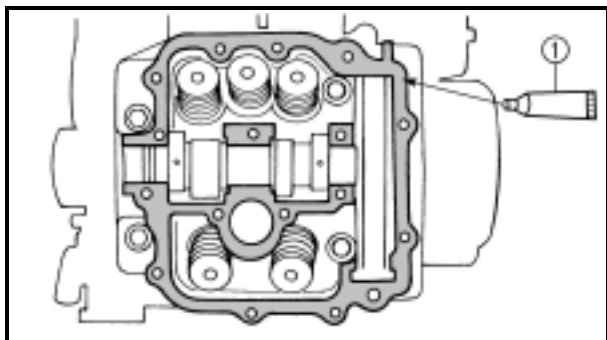

### INSTALLING THE CYLINDER HEAD COVER

1. Apply:

- Sealant (Quick Gasket®) ①  
(to the mating surfaces of the cylinder head and cylinder head cover)



**Sealant (Quick Gasket®) ①:**  
**P/N. ACC-11001-05-01**  
**Yamaha bond No. 1215®:**  
**P/N. 90890-85505**

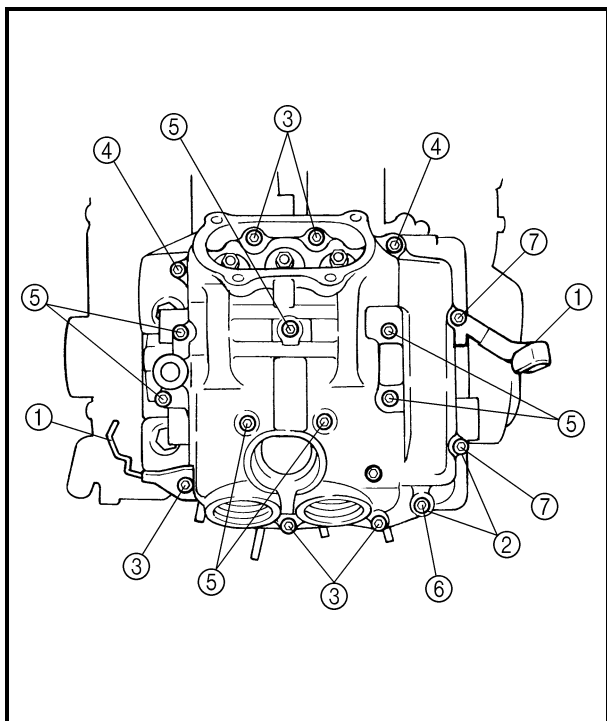

2. Install:

- Cylinder head cover
- Cable guides ①
- Washers ②
- Bolts **10 Nm (1.0 m • kg, 7.2 ft • lb)**
- ③ Bolt:  $\ell = 25 \text{ mm}$
- ④ Bolt:  $\ell = 40 \text{ mm}$
- ⑤ Bolt:  $\ell = 55 \text{ mm}$
- ⑥ Bolt:  $\ell = 115 \text{ mm}$
- ⑦ Bolt:  $\ell = 130 \text{ mm}$

### NOTE:

Tighten the cylinder head cover bolts in stages, using a crisscross pattern.



ROCKER ARMS

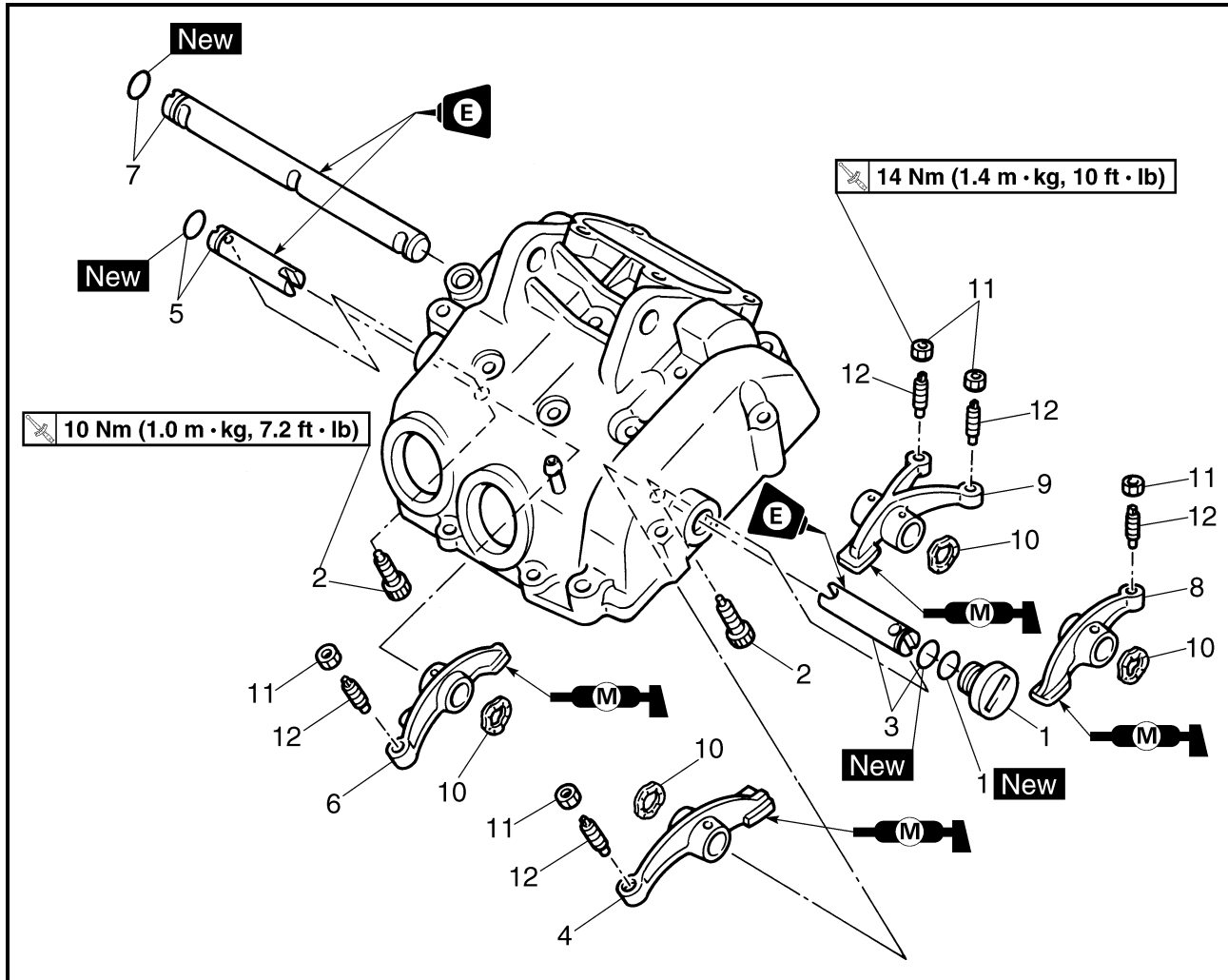

Order	Job name/Part name	Q'ty	Remarks
	<b>Removing the rocker arm</b>		
	Cylinder head cover		Remove the parts in the order below. Refer to "CYLINDER HEAD COVER".
1	Plug/O-ring	1/1	
2	Bolt	2	
3	Rocker arm shaft 2/O-ring	1/1	
4	Rocker arm 3	1	
5	Rocker arm shaft 3/O-ring	1/1	
6	Rocker arm 4	1	Refer to "REMOVING/INSTALLING THE ROCKER ARM".
7	Rocker arm shaft 1/O-ring	1/1	
8	Rocker arm 1	1	
9	Rocker arm 2	1	



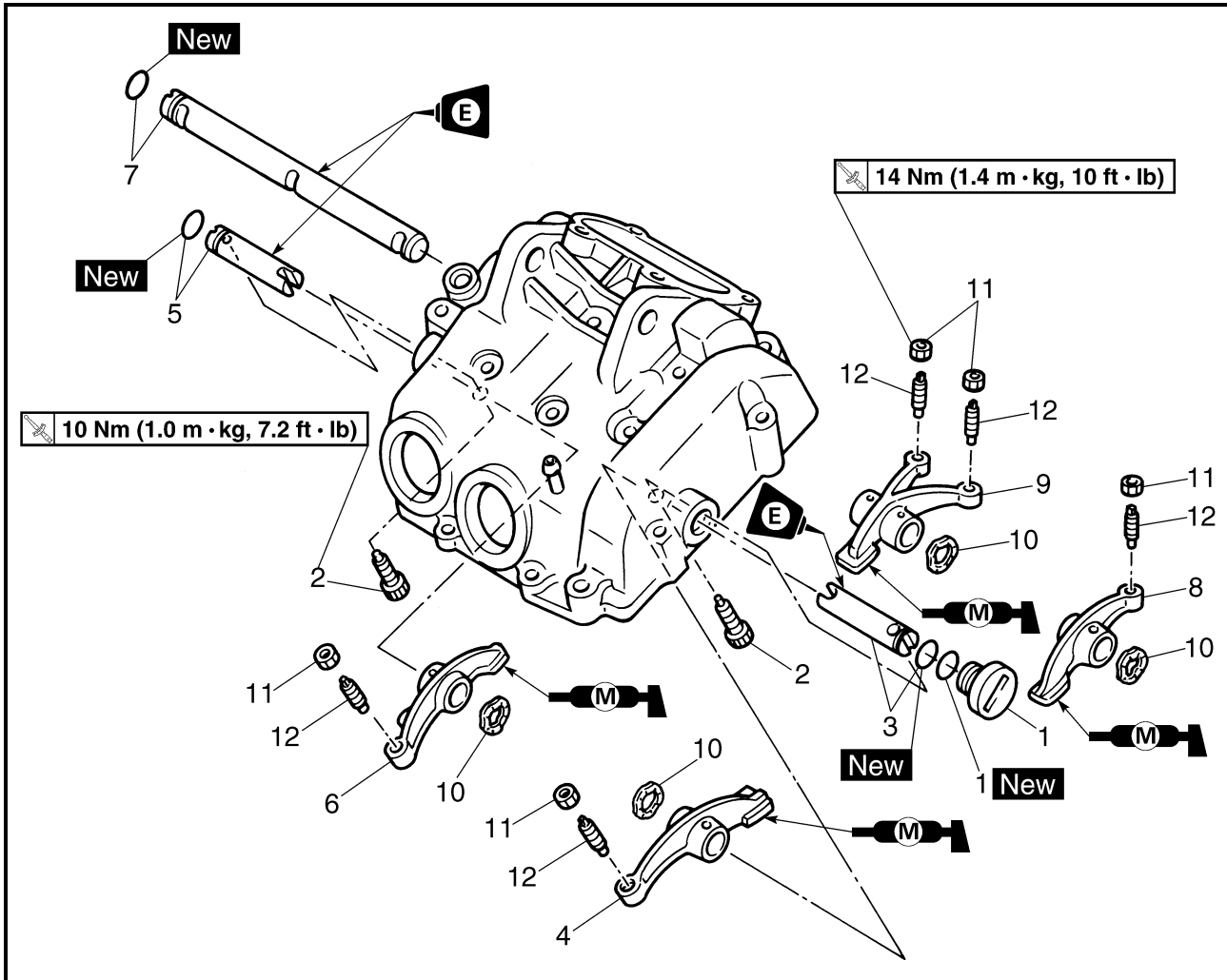

Order	Job name/Part name	Q'ty	Remarks
10	Spring	4	For installation, reverse the removal procedure.
11	Locknut	5	
12	Valve adjuster	5	

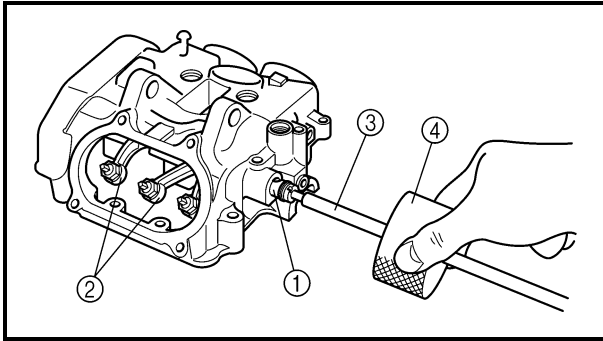

## REMOVING THE ROCKER ARM

1.Remove:

- Rocker arm shafts ①
- Rocker arms ②

### NOTE:

Use a slide hammer bolt ③ and weight ④ to remove the rocker arm shafts.



**Slide hammer set:**

**P/N. YU-01083-A**

**Slide hammer bolt (M6):**

**P/N. 90890-01083**

**Weight:**

**P/N. 90890-01084**

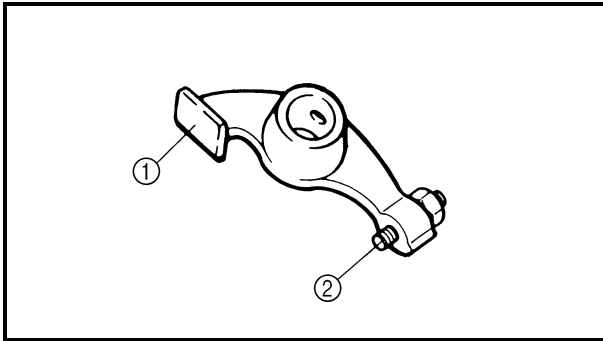

## CHECKING THE ROCKER ARM

1.Check:

- Rocker arm lobes ①
- Valve adjusters ②  
Blue discoloration/pitting/scratches → Replace.

2.Check:

- Rocker arms
- Rocker arm shafts  
Damage/wear → Replace.

\*\*\*\*\*

### Checking steps:

- Check the two contact areas on the rocker arms for signs of abnormal wear.
  - 1) Rocker arm shaft hole.
  - 2) Camshaft lobe contact surface.
 Excessive wear → Replace.
- Check the surface of the rocker arm shafts.  
Blue discoloration/pitting/scratches → Replace/check lubrication.
- Measure the inside diameter @ of the rocker arm holes.  
Out of specification → Replace.

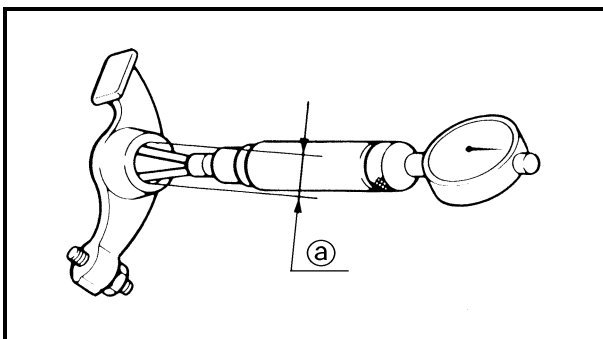

**Rocker arm inside diameter:**

**12.000 ~ 12.018 mm**

**(0.4724 ~ 0.4731 in)**

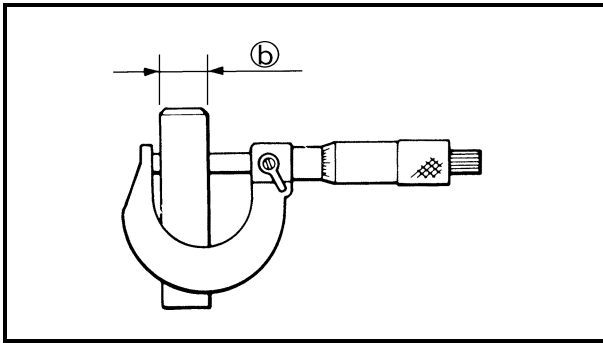

- Measure the outside diameter ⑥ of the rocker arm shafts.  
Out of specification → Replace.



**Rocker arm outside diameter:**  
**11.976 ~ 11.991 mm**  
**(0.4715 ~ 0.4721 in)**

- Calculate the clearance by subtracting the rocker arm shaft outside diameter from the rocker arm inside diameter.  
Clearance greater than 0.08 mm (0.003 in)  
→ Replace the defective part(s).



**Rocker arm to shaft standard clearance:**  
**0.009 ~ 0.042 mm**  
**(0.0004 ~ 0.0017 in)**

\*\*\*\*\*

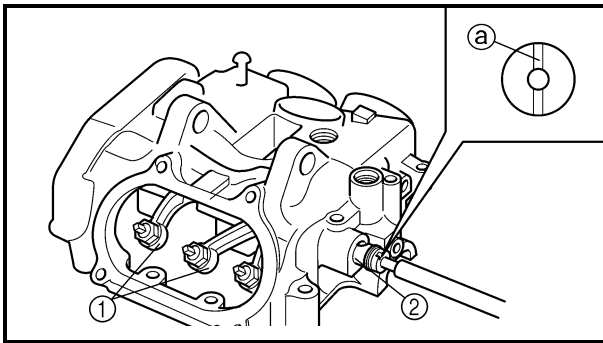

## INSTALLING THE ROCKER ARM

1. Apply:
  - Engine oil  
(onto the rocker arm shafts)
2. Install:
  - Rocker arms ①
  - Rocker arm shafts ②

### NOTE:

- The thread hole ① of the rocker arm shaft must face to the outside.
- After installation, make sure that the thread hole ① of the rocker arm shaft is positioned correctly, as shown in the illustration.



CAMSHAFT AND CYLINDER HEAD

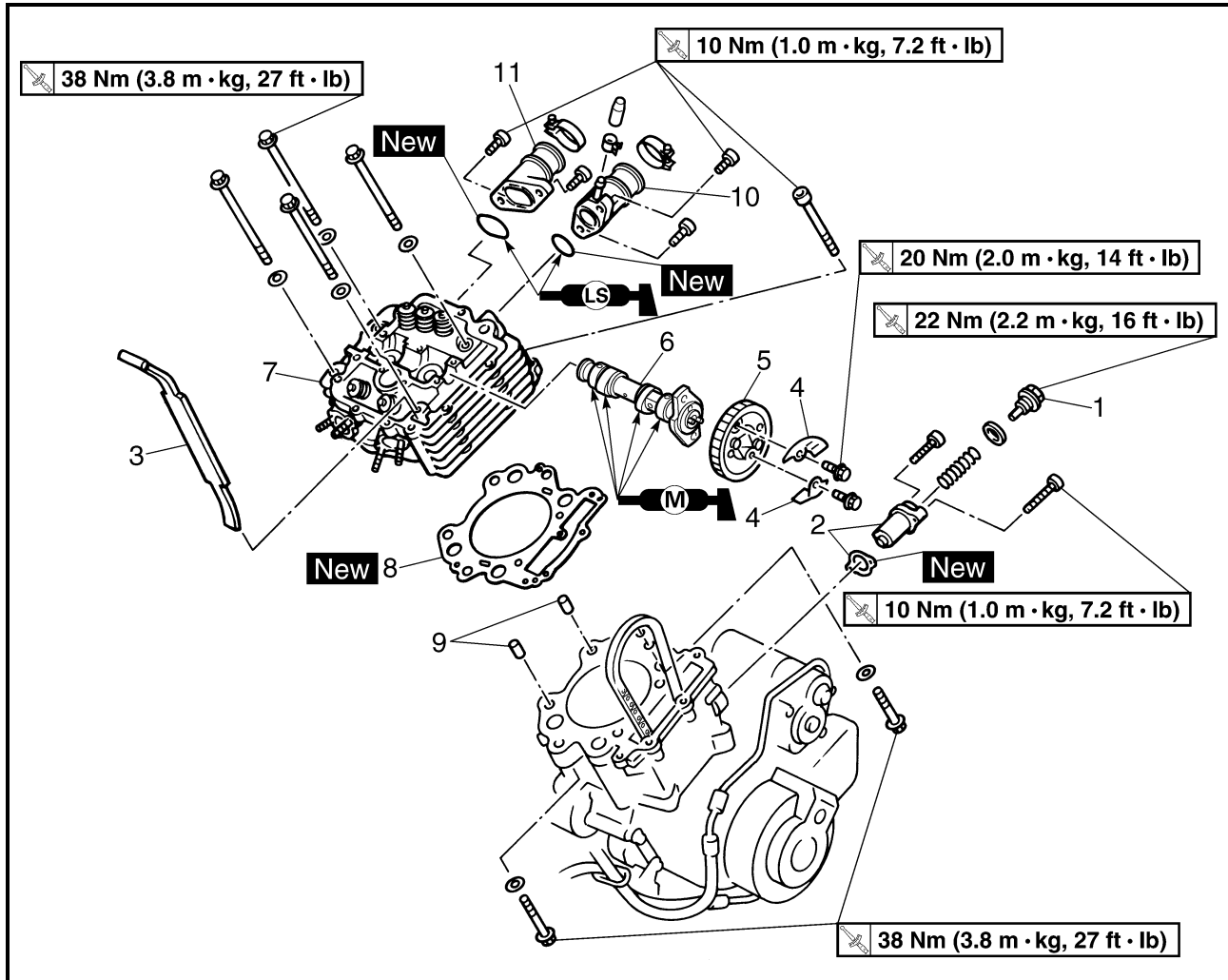

Order	Job name/Part name	Q'ty	Remarks
	<b>Removing the camshaft and cylinder head</b>		Remove the parts in the order below.
	Seat/front fender		Refer to "SEAT, FENDERS AND FUEL TANK" in CHAPTER 3.
	Fuel tank/rubber covers		Refer to "CARBURETORS" in CHAPTER 7.
	Carburetors		Refer to "THERMOSTAT" in CHAPTER 6.
	Water jacket outlet pipe		Refer to "ENGINE REMOVAL".
	Muffler/exhaust pipe		Refer to "CYLINDER HEAD COVER".
	Cylinder head cover		
1	Timing chain tensioner cap bolt	1	
2	Timing chain tensioner/gasket	1/1	
3	Timing chain guide (exhaust)	1	Refer to "REMOVING/INSTALLING THE CAMSHAFT AND CYLINDER HEAD".
4	Decompressor cam guide plate	2	
5	Camshaft sprocket	1	

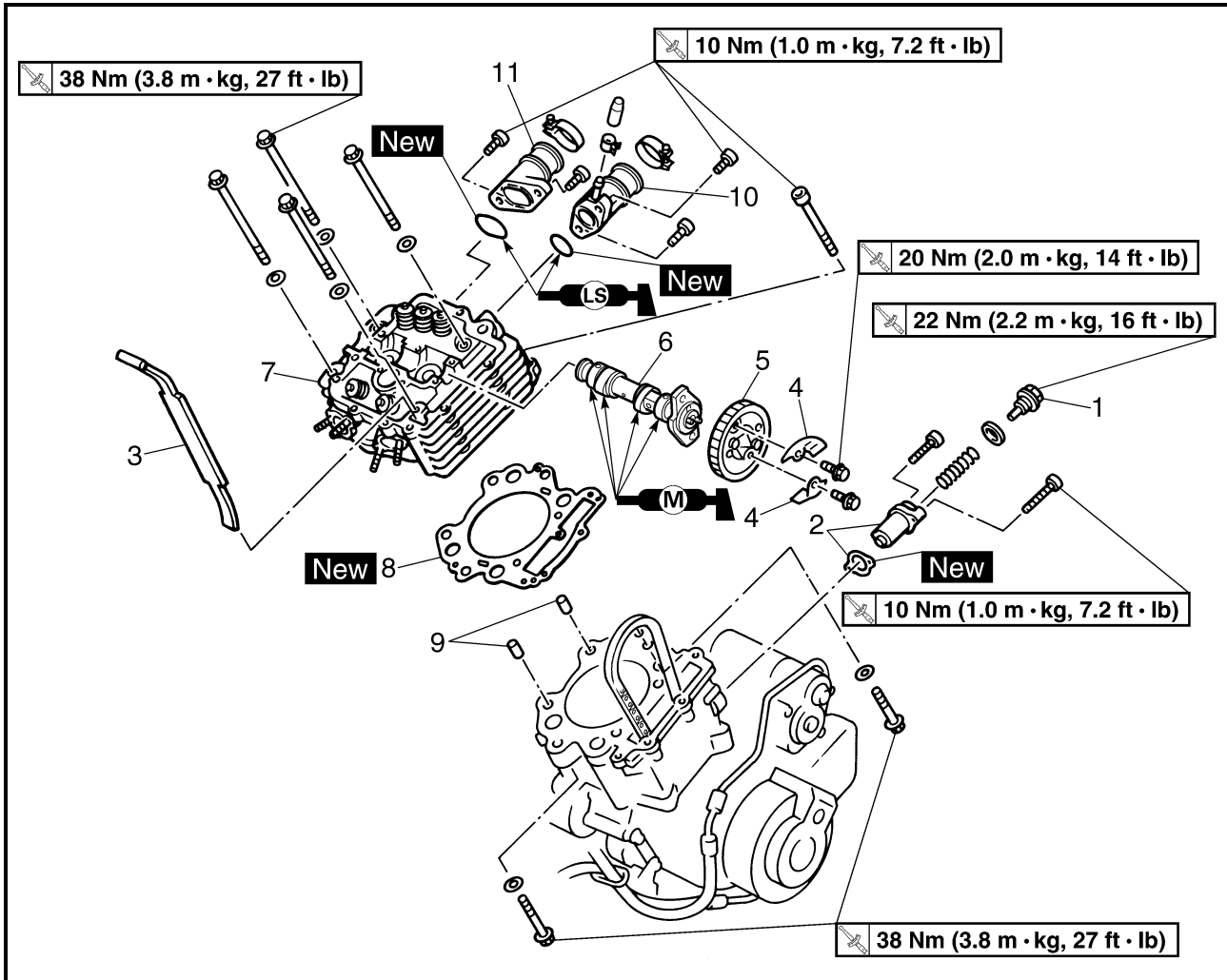

Order	Job name/Part name	Q'ty	Remarks
6	Camshaft	1	Refer to "CAMSHAFT AND CYLINDER HEAD".
7	Cylinder head	1	
8	Cylinder head gasket	1	
9	Dowel pin	2	
10	Carburetor joint 1	1	
11	Carburetor joint 2	1	
			For installation, reverse the removal procedure.

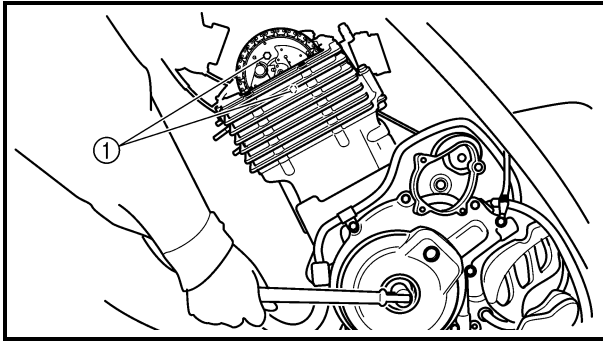

### REMOVING THE CAMSHAFT AND CYLINDER HEAD

#### 1. Loosen:

- Camshaft sprocket bolts ①

#### 2. Loosen:

- Timing chain tensioner cap bolt

#### 3. Remove:

- Timing chain tensioner
- Timing chain guide (exhaust)
- Decompressor cam guide plates
- Camshaft sprocket

#### NOTE:

- Fasten a safety wire to the timing chain to prevent it from falling into the crankcase.
- When removing the camshaft sprocket, it is not necessary to separate the timing chain.

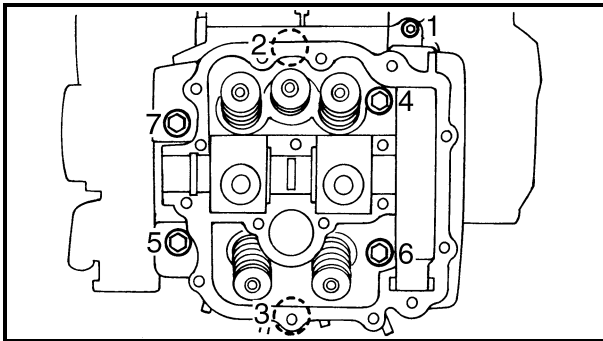

#### 4. Remove:

- Cylinder head

#### NOTE:

- Loosen the bolts in the proper sequence.
- Follow the numerical order shown in the illustration. Loosen each bolt 1/4 of a turn at a time until all of the bolts are loose.

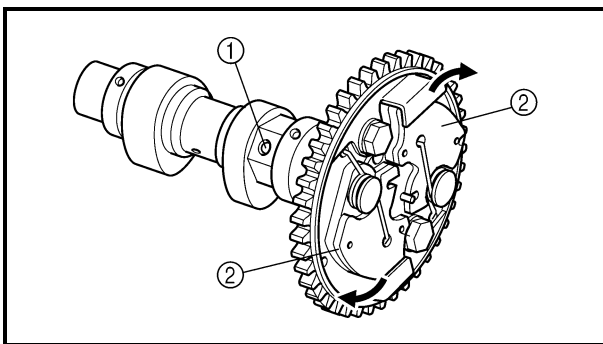
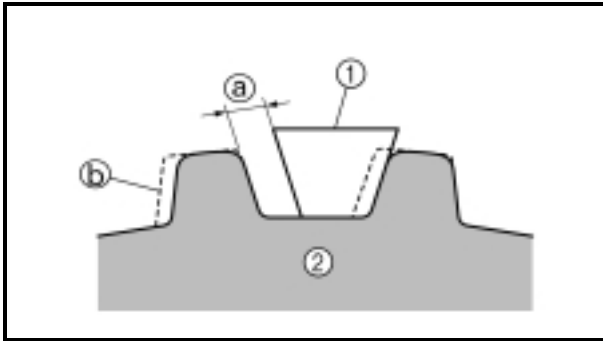
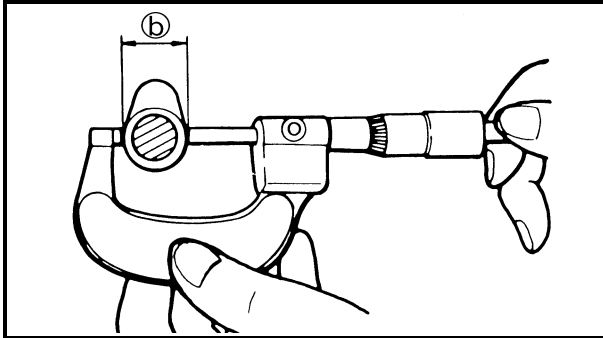
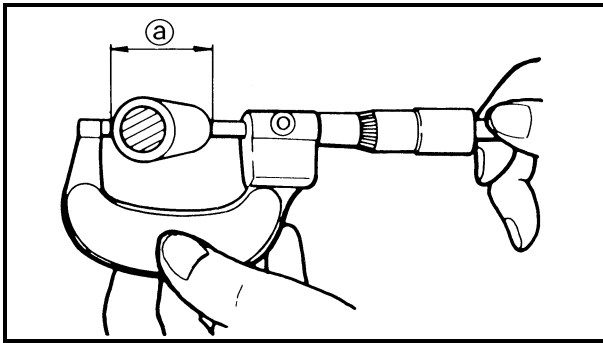

## CHECKING THE CAMSHAFT

1. Check:
  - Cam lobes
    - Pitting/scratches/blue discoloration → Replace.
2. Measure:
  - Cam lobes length (a) and (b).
    - Out of specification → Replace.



### Camshaft lobe limit:

#### Intake:

(a) 35.59 mm (1.4012 in)

(b) 30.05 mm (1.1831 in)

#### Exhaust:

(a) 36.40 mm (1.4331 in)

(b) 30.05 mm (1.1831 in)

## CHECKING THE CAMSHAFT SPROCKET

1. Check:
    - Camshaft sprocket
      - Wear/damage → Replace the camshaft sprocket and timing chain as a set.
- (a) 1/4 of a tooth  
 (b) Correct  
 ① Timing chain  
 ② Sprocket

## CHECKING THE DECOMPRESSION SYSTEM

1. Check:
  - Decompression system

\*\*\*\*\*

### Checking steps:

Check while the camshaft sprocket is installed on the camshaft.

- Check that the decompressor lever pin (1) projects from the camshaft.
- Check that the decompressor cam (2) moves smoothly.

\*\*\*\*\*

**CHECKING THE TIMING CHAIN GUIDE**

1.Check:

- Exhaust side timing chain guide  
Wear/damage → Replace.

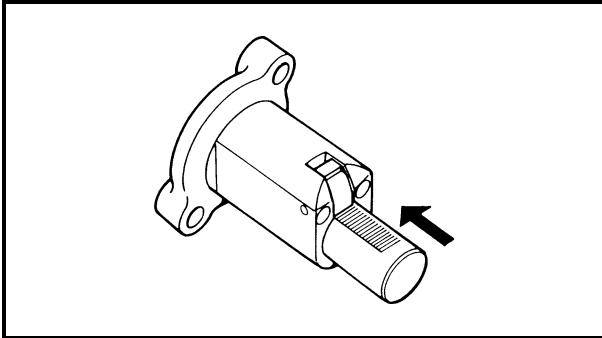
**CHECKING THE TIMING CHAIN TENSIONER**

1.Check:

- One-way cam operation (tensioner)  
Unsmooth operation → Replace.

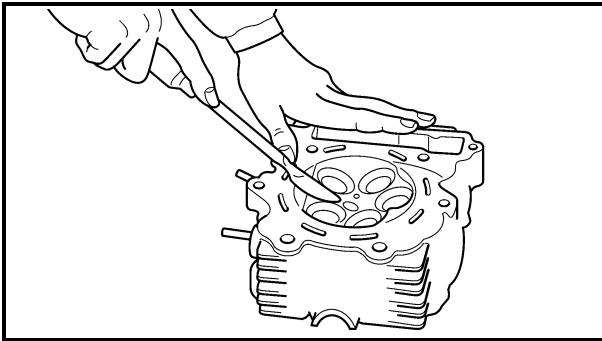
**CHECKING THE CYLINDER HEAD**

1.Eliminate:

- Carbon deposits (from the combustion chambers)  
Use a rounded scraper.

**NOTE:**

Do not use a sharp instrument to avoid damaging or scratching:

- Spark plug threads
- Valve seats

2.Check:

- Cylinder head  
Scratches/damage → Replace the cylinder head cover and cylinder head as a set.
- Cylinder head water jacket  
Mineral deposits/rust → Eliminate.



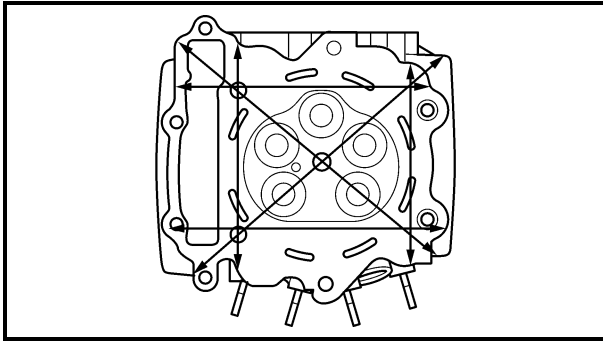

3.Measure:

- Cylinder head warpage  
Out of specification → Resurface.



**Cylinder head warpage:  
Less than 0.05 mm (0.002 in)**

\*\*\*\*\*

### Warpage measurement and resurfacing steps:

- Place a straightedge and a feeler gauge across the cylinder head.
- Use a feeler gauge to measure the warpage.
- If the warpage is out of specification, resurface the cylinder head.
- Place a 400 ~ 600 grit wet sandpaper on the surface plate, and resurface the head using a figure-eight sanding pattern.

### NOTE:

To ensure an even surface rotate the cylinder head several times.

\*\*\*\*\*

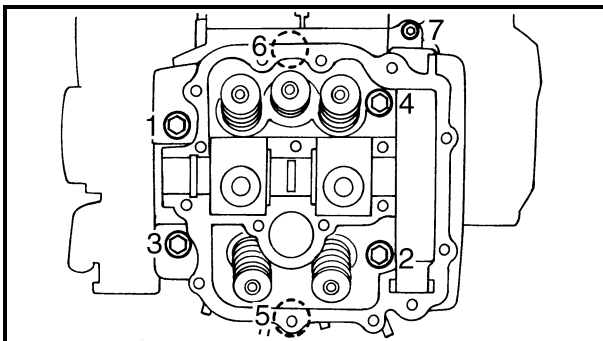

### INSTALLING THE CAMSHAFT AND CYLINDER HEAD

1.Install:

- Cylinder head
- Bolts (M9 : 1 ~ 6)

	<b>38 Nm (3.8 m · kg, 27 ft · lb)</b>
--	---------------------------------------

- Bolt (M6 : 7)

	<b>10 Nm (1.0 m · kg, 7.2 ft · lb)</b>
--	--

### NOTE:

- Tighten the bolts in the proper sequence.
- Follow the numerical order shown in the illustration. Tighten the bolts in two stages.

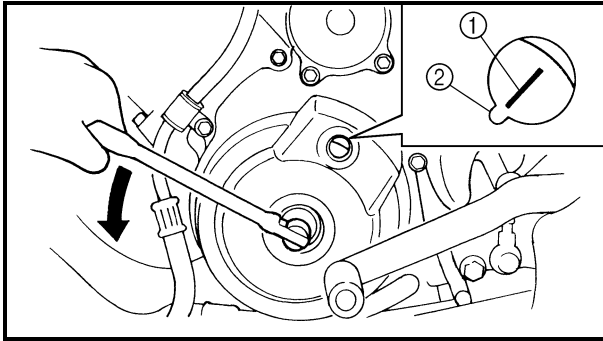

2. Install:

- Camshaft
- Camshaft sprocket

\*\*\*\*\*

**Installation steps:**

- Turn the crankshaft counterclockwise with a wrench.
- Align the "I" mark ① on the rotor with the stationary pointer ② on the crankcase cover. When the "I" mark is aligned with the stationary pointer, the piston is at the Top Dead Center (T.D.C.).

**CAUTION:**

**Do not turn the crankshaft during the camshaft installation.**

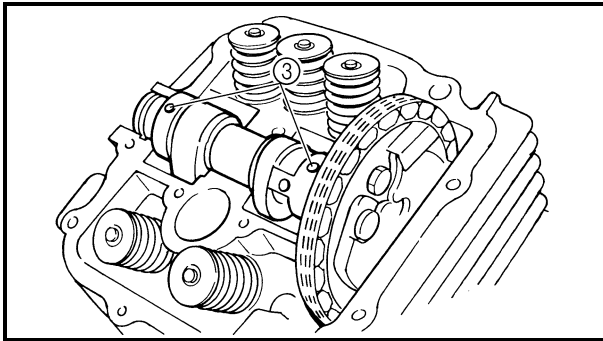

- Temporarily install the camshaft sprocket on the camshaft. (Do not install the bolts.) Then, install the timing chain on the camshaft sprocket.

**NOTE:**

Make sure the small holes ③ on the camshaft face upward.

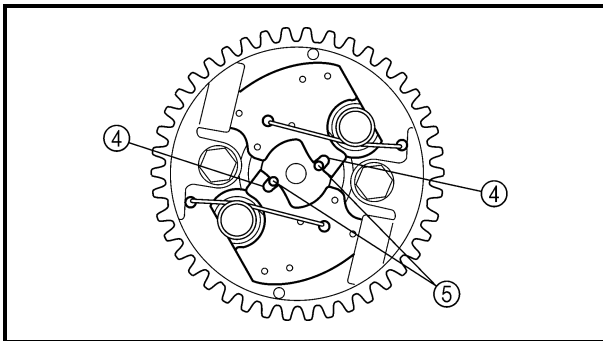

- Align the notches ④ on the decompressor cams with the projections ⑤ on the decompressor spring lever, then install the camshaft sprocket on the camshaft.

**NOTE:**

Check that each part is positioned as shown in the illustration.

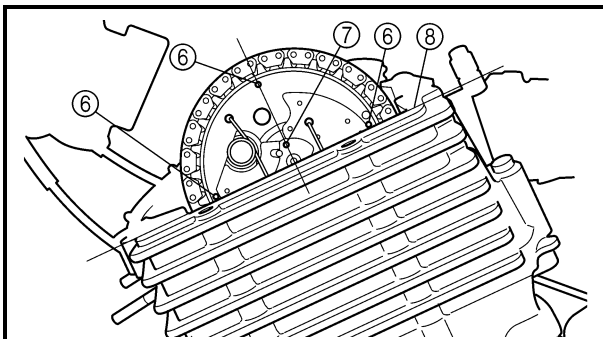

- ⑥ Small holes on camshaft sprocket
- ⑦ Punch mark on decompressor spring lever
- ⑧ Top front of cylinder head

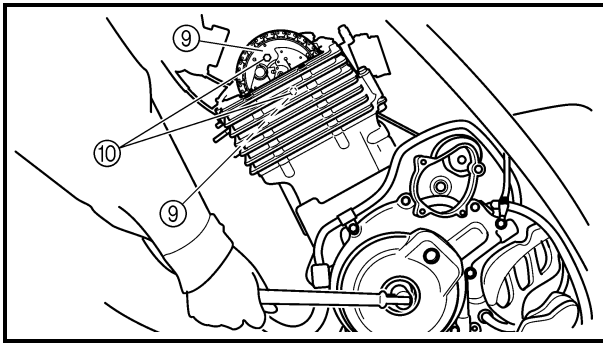

- Install the decompressor cam guide plates ⑨ and camshaft sprocket bolts ⑩.



**Camshaft sprocket bolt:**  
20 Nm (2.0 m • kg, 14 ft • lb)

- Remove the retaining wire.

\*\*\*\*\*

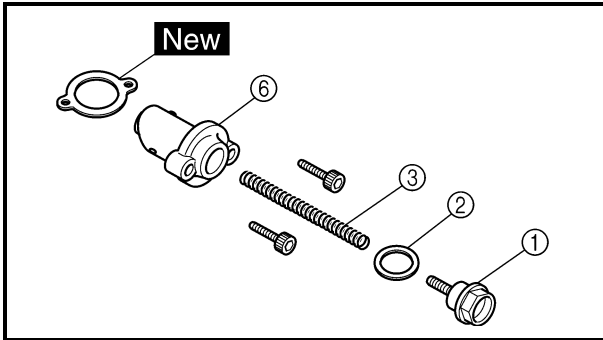

### 3. Install:

- Timing chain tensioner

\*\*\*\*\*

### Installation steps:

- Remove the timing chain tensioner cap bolt ①, washer ② and spring ③.
- Release the timing chain tensioner one-way cam ④ and push the tensioner rod ⑤ all the way in.
- Install the tensioner ⑥ with a new gasket into the cylinder.

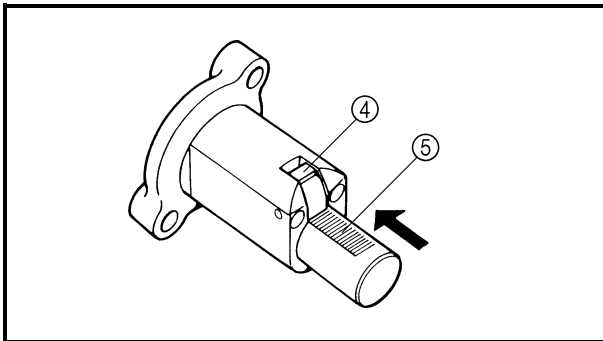

**Bolts (timing chain tensioner):**  
10 Nm (1.0 m • kg, 7.2 ft • lb)

### ⚠ WARNING

**Always use a new gasket.**

- Install the spring, washer and timing chain tensioner cap bolt.



**Timing chain tensioner cap bolt:**  
22 Nm (2.2 m • kg, 16 ft • lb)

\*\*\*\*\*

### 4. Check:

- Small holes on camshaft sprocket
- Rotor "I" mark  
Out of alignment → Adjust.



VALVES AND VALVE SPRINGS

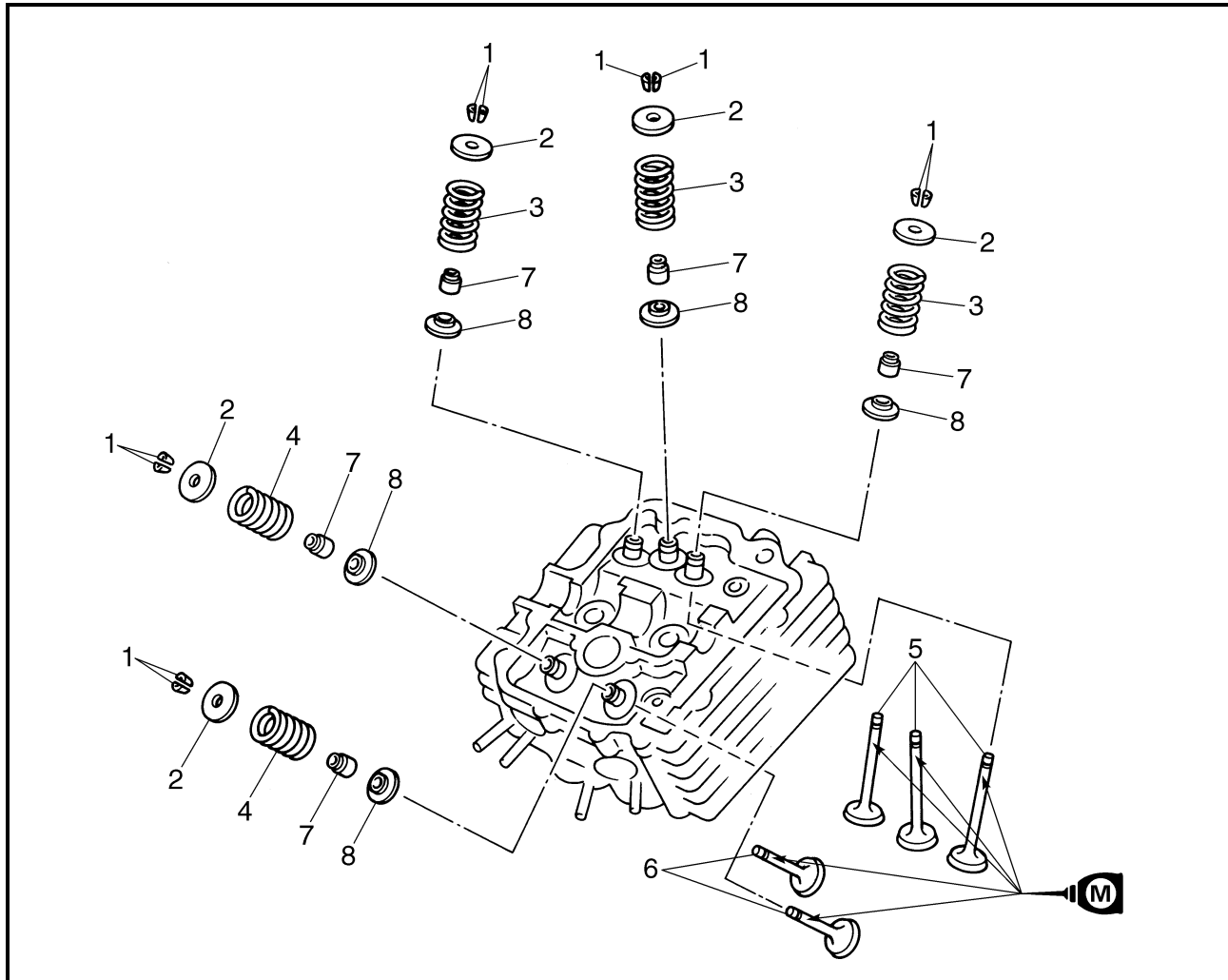

Order	Job name/Part name	Q'ty	Remarks
	<b>Removing the valve and valve spring</b>		Remove the parts in the order below.
	Cylinder head		Refer to "CAMSHAFT AND CYLINDER HEAD".
1	Valve cotter	10	
2	Valve spring retainer	5	
3	Intake valve spring	3	
4	Exhaust valve spring	2	Refer to "REMOVING/INSTALLING THE VALVE AND VALVE SPRING".
5	Intake valve	3	
6	Exhaust valve	2	
7	Valve stem seal	5	
8	Valve spring seat	5	
			For installation, reverse the removal procedure.

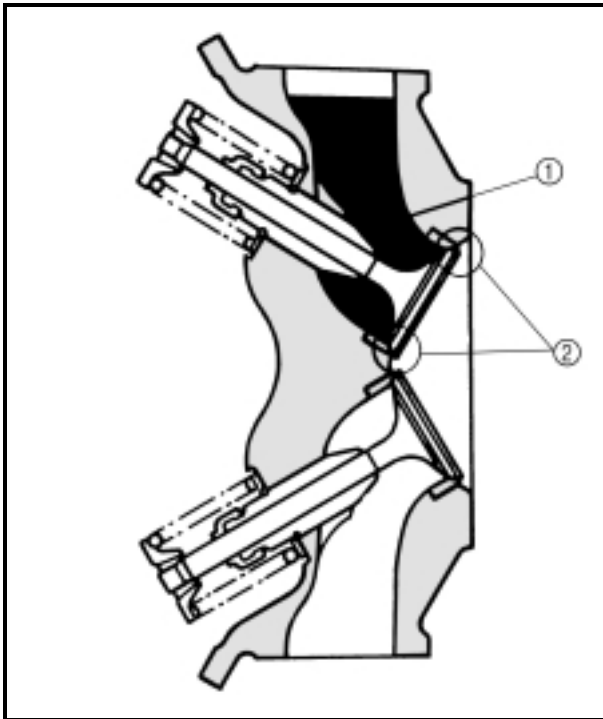

**REMOVING THE VALVE AND VALVE SPRING**

1. Check:

- Valve sealing  
Leakage at the valve seat → Inspect the valve face, valve seat and valve seat width. Refer to “VALVE AND VALVE SPRING INSPECTION”.

\*\*\*\*\*

**Checking steps:**

- Pour a clean solvent ① into the intake and exhaust ports.
- Check that the valve seals properly. There should be no leakage at the valve seat ②.

\*\*\*\*\*

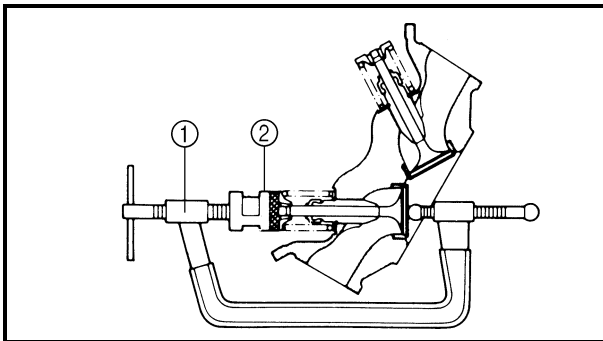

2. Remove:

- Valve cotters

**NOTE:**

Attach a valve spring compressor ① and attachment ② between the valve spring retainer and the cylinder head to remove the valve cotters.



**Valve spring compressor:**  
P/N. YM-04019, 90890-04019  
**Valve spring compressor attachment:**  
P/N. 90890-01243

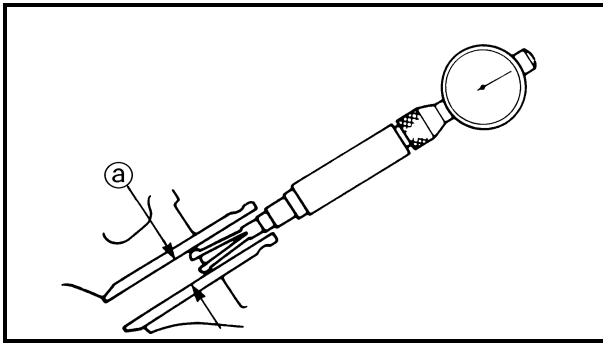

## CHECKING THE VALVE AND VALVE SPRING

1.Measure:

- Stem-to-guide clearance

$$\text{Stem-to-guide clearance} = \text{valve guide inside diameter (a)} - \text{valve stem diameter (b)}$$

Out of specification → Replace the valve guide.

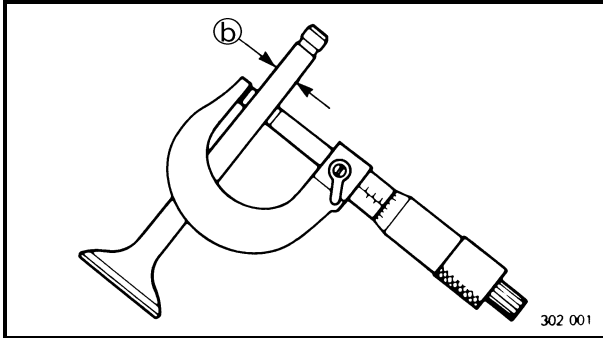

### Clearance (stem to guide):

Intake:

0.010 ~ 0.037 mm

(0.0004 ~ 0.0015 in)

<Limit>: 0.08 mm (0.0031 in)

Exhaust:

0.025 ~ 0.052 mm

(0.0010 ~ 0.0020 in)

<Limit>: 0.10 mm (0.0039 in)

2.Replace:

- Valve guide

\*\*\*\*\*

### Replacement steps:

#### NOTE:

To ease guide removal, installation and to maintain correct fit, heat the cylinder head to 100 °C (212 °F) in an oven.

- Remove the valve guide using a valve guide remover ①.
- Install the new valve guide using a valve guide remover ① and valve guide installer ②.
- After installing the valve guide, bore the valve guide using a valve guide reamer ③ to obtain proper stem-to-guide clearance.

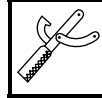
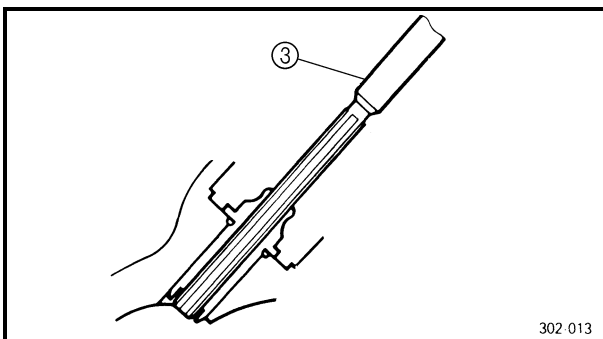
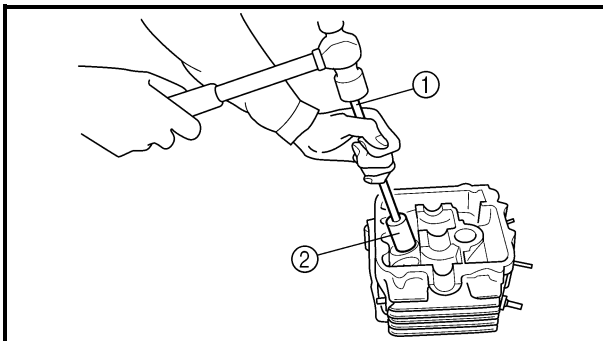
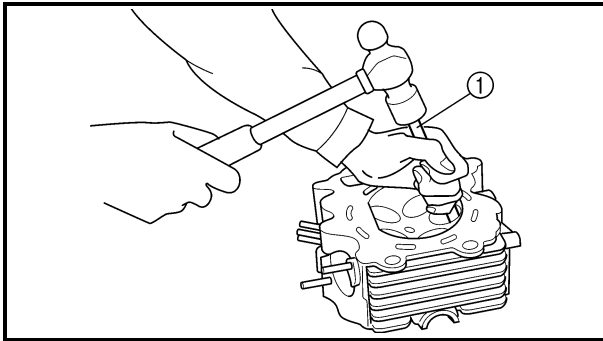

Valve guide remover (ø 6):

P/N. YM-4064-A, 90890-04064

Valve guide installer (ø 6):

P/N. YM-04065-A, 90890-04065

Valve guide reamer (ø 6):

P/N. YM-04066, 90890-04066

#### NOTE:

After replacing the valve guide reface the valve seat.

\*\*\*\*\*



3. Check:

- Valve face  
Pitting/wear → Grind the face.
- Valve stem end  
Mushroom shape or diameter larger than the body of the stem → Replace.

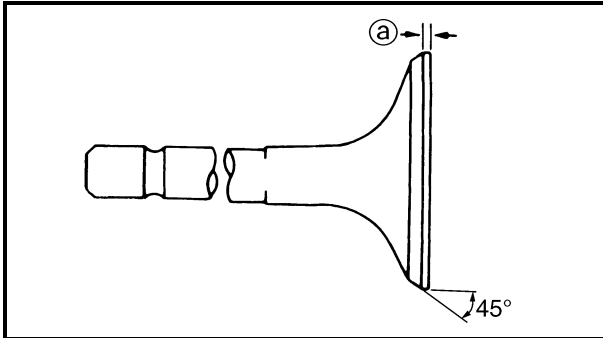

4. Measure:

- Margin thickness (a)  
Out of specification → Replace.



**Margin thickness:**

**Intake:**

0.85 ~ 1.15 mm  
(0.0335 ~ 0.0453 in)

**Exhaust:**

0.85 ~ 1.15 mm  
(0.0335 ~ 0.0453 in)

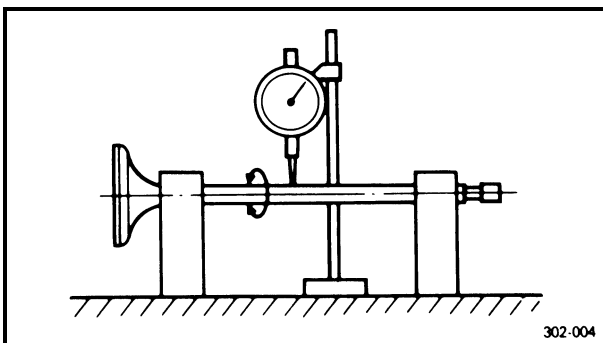

5. Measure:

- Runout (valve stem)  
Out of specification → Replace.



**Runout limit:**

0.01 mm (0.0004 in)

**NOTE:**

- When installing a new valve always replace the guide.
- If the valve is removed or replaced always replace the oil seal.

6. Eliminate:

- Carbon deposits  
(from the valve face and valve seat)

7. Check:

- Valve seats  
Pitting/wear → Reface the valve seat.

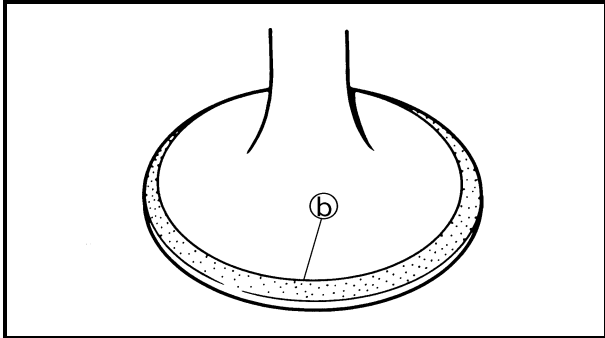
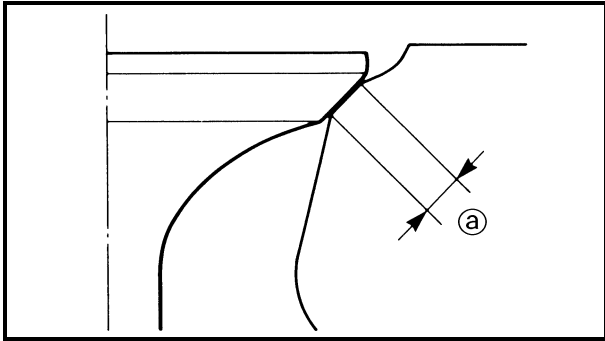

8.Measure:

- Valve seat width (a)
- Out of specification → Reface the valve seat.



**Valve seat width:**  
**Intake:**  
 0.9 ~ 1.1 mm  
 (0.0354 ~ 0.0433 in)  
 <Limit>: 1.6 mm (0.0630 in)  
**Exhaust:**  
 0.9 ~ 1.1 mm  
 (0.0354 ~ 0.0433 in)  
 <Limit>: 1.6 mm (0.0630 in)

\*\*\*\*\*

**Measurement steps:**

- Apply Mechanic's blueing dye (Dykem) (b) to the valve face.
- Install the valve into the cylinder head.
- Press the valve through the valve guide and onto the valve seat to make a clear pattern.
- Measure the valve seat width. Where the valve seat and valve face made contact, blueing will have been removed.
- If the valve seat is too wide, too narrow, or the seat is not centered, the valve seat must be refaced.

\*\*\*\*\*

9.Lap:

- Valve face
- Valve seat

**NOTE:** \_\_\_\_\_  
 After refacing the valve seat or replacing the valve and valve guide, the valve seat and valve face should be lapped.

\*\*\*\*\*

**Lapping steps:**

- Apply a coarse lapping compound to the valve face.

**CAUTION:** \_\_\_\_\_  
**Do not let the compound enter the gap between the valve stem and the guide.**

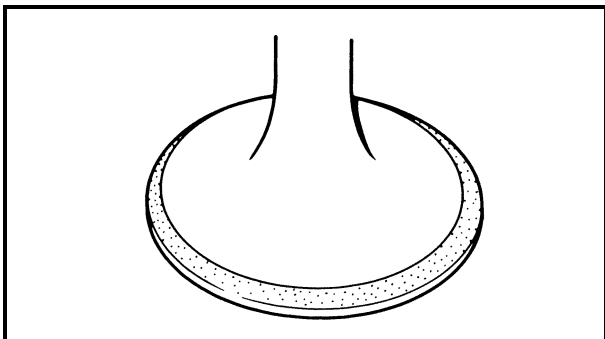

- Apply molybdenum disulfide oil to the valve stem.



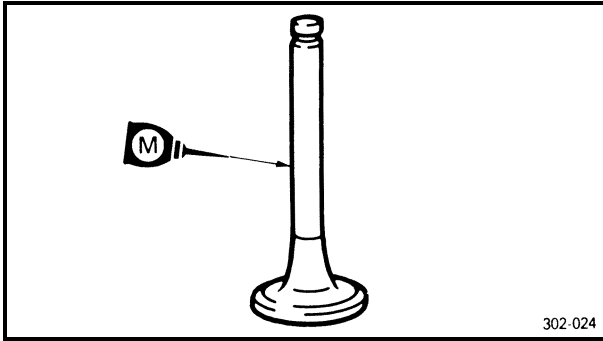

302-024

- Install the valve into the cylinder head.
- Turn the valve until the valve face and valve seat are evenly polished, then clean off all of the compound.

**NOTE:** \_\_\_\_\_  
For best lapping results, lightly tap the valve seat while rotating the valve back and forth between your hands.

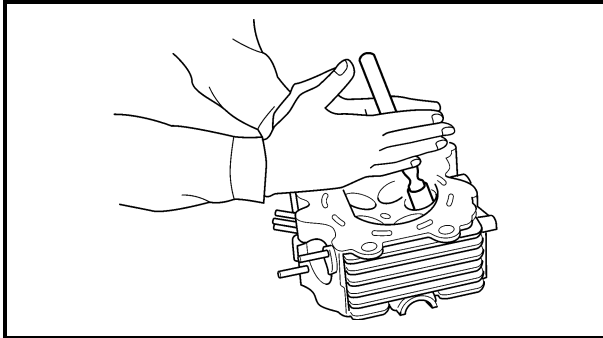

- Apply a fine lapping compound to the valve face and repeat the above steps.

**NOTE:** \_\_\_\_\_  
After every lapping operation be sure to clean off all of the compound from the valve face and valve seat.

- Apply Mechanic's blueing dye (Dykem) to the valve face.
- Install the valve into the cylinder head.
- Press the valve through the valve guide and onto the valve seat to make a clear pattern.
- Measure the valve seat width again. If the valve seat width is out of specification, reface and relap the valve seat.

\*\*\*\*\*

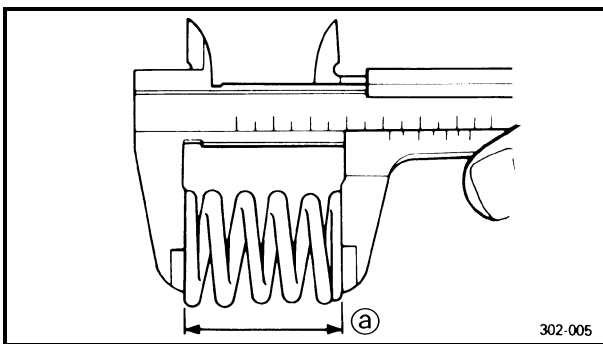

302-005

10.Measure:

- Valve spring free length (a)  
Out of specification → Replace.

	<b>Free length (valve spring):</b>
	<b>Inner:</b>
	35.95 mm (1.42 in)
	<Limit>: 34.15 mm (1.34 in)
	<b>Outer:</b>
	37.75 mm (1.49 in)
	<Limit>: 35.86 mm (1.41 in)

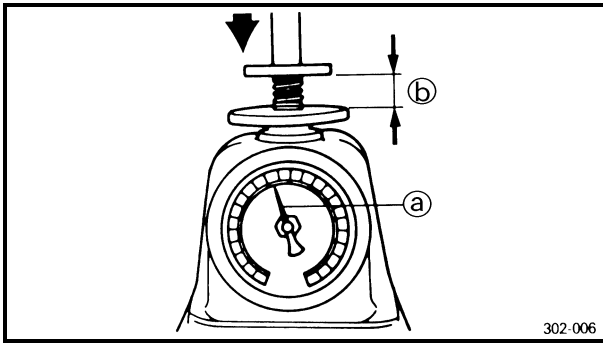

11.Measure:

- Compressed spring force (a)  
Out of specification → Replace.
- (b) Installed length



**Compressed spring force:**

**Inner:**

149 ~ 173 N at 27.2 mm  
(15.19 ~ 17.64 kg,  
33.50 ~ 38.89 lb at 1.07 in)

**Outer:**

165 ~ 191 N at 30.7 mm  
(16.83 ~ 19.49 kg,  
37.09 ~ 42.94 lb at 1.21 in)

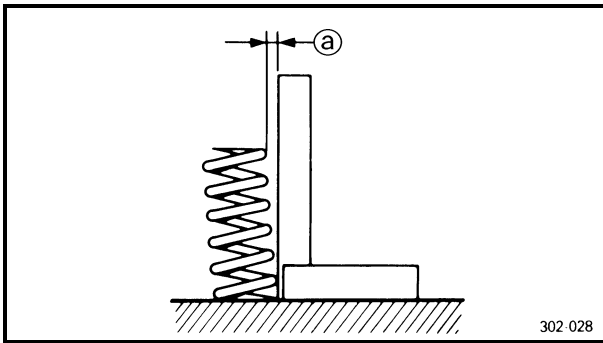

12.Measure:

- Spring tilt (a)  
Out of specification → Replace.



**Spring tilt limit:**

**Inner:**

2.5°/1.6 mm (0.06 in)

**Outer:**

2.5°/1.6 mm (0.06 in)

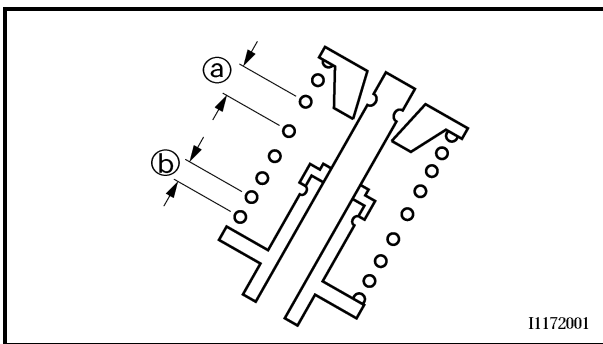

**INSTALLING THE VALVE AND VALVE SPRING**

1.Apply:

- Molybdenum disulfide oil  
(onto the valve stem and valve stem seal)

2.Install:

- Valve spring seats
- Valve stem seals **New**
- Valves
- Valve springs
- Valve spring retainers

**NOTE:**

Install the valve springs with the larger pitch (a)  
facing upwards.

(b) Smaller pitch

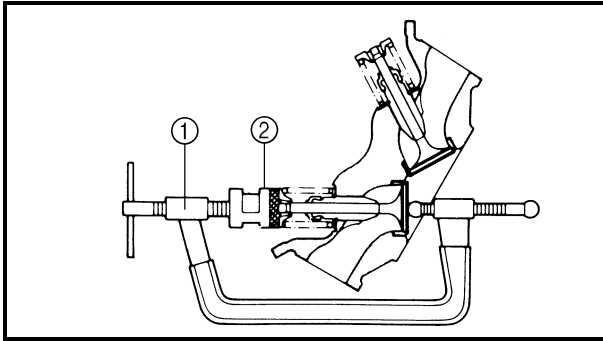

3. Install:

- Valve cotters

**NOTE:**

Install the valve cotters while compressing the valve spring with the valve spring compressor ① and attachment ②.



**Valve spring compressor:**  
**P/N. YM-04019, 90890-04019**  
**Valve spring compressor**  
**attachment:**  
**P/N. 90890-01243**

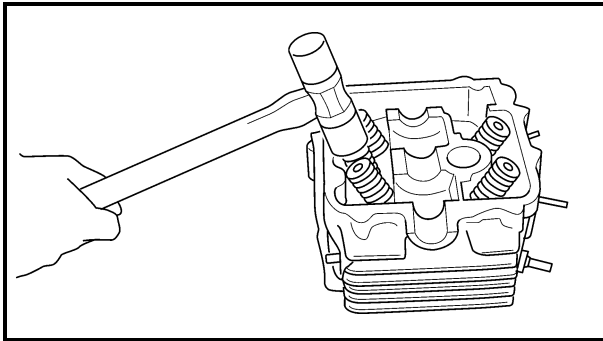

4. To secure the valve cotters onto the valve stem, lightly tap the valve tip with a piece of wood.

**CAUTION:**

Hitting the valve tip with excessive force could damage the valve.



CYLINDER AND PISTON

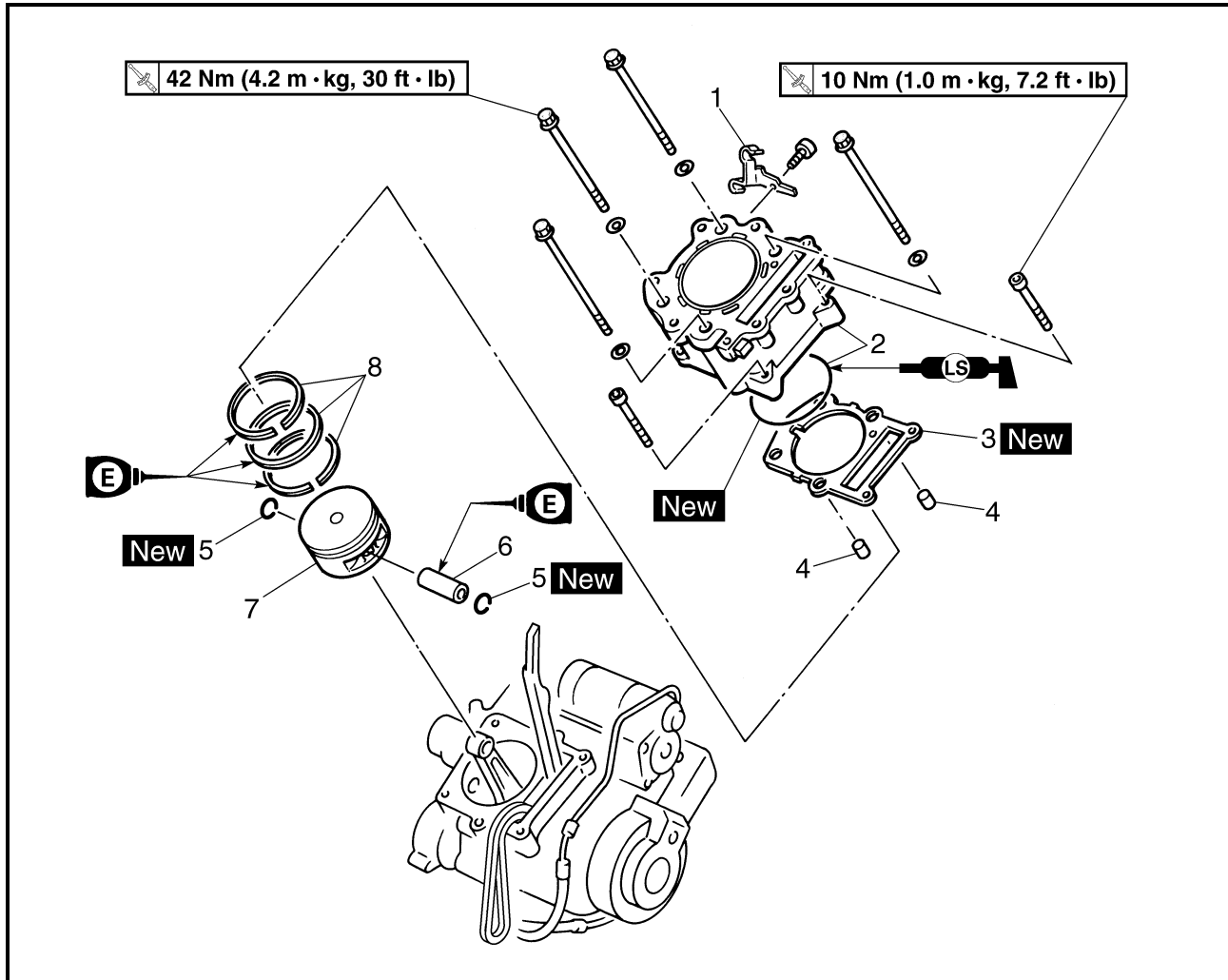

Order	Job name/Part name	Q'ty	Remarks
	<b>Removing the cylinder and piston</b>		Remove the parts in the order below.
	Water jacket inlet housing		Refer to "WATER PUMP" in CHAPTER 6.
	Cylinder head		Refer to "CAMSHAFT AND CYLINDER HEAD".
1	Cable guide	1	
2	Cylinder/O-ring	1/1	Refer to "INSTALLING THE CYLINDER".
3	Cylinder gasket	1	
4	Dowel pin	2	
5	Piston pin clip	2	
6	Piston pin	1	Refer to "REMOVING/INSTALLING THE PISTON".
7	Piston	1	
8	Piston ring set	1	
			For installation, reverse the removal procedure.

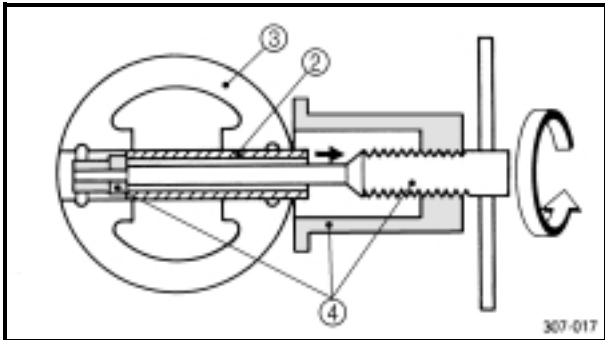
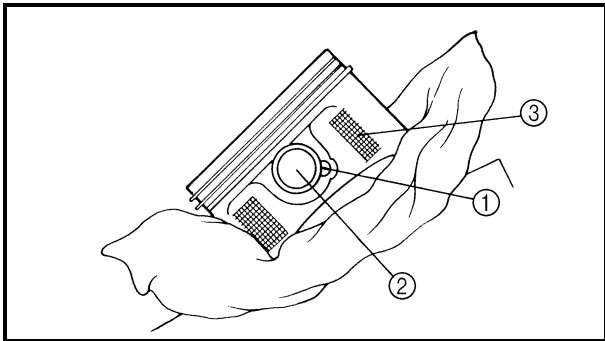

**REMOVING THE PISTON**

1.Remove:

- Piston pin clips ①
- Piston pin ②
- Piston ③

**NOTE:**

- Put identification marks on each piston head for reference during reinstallation.
- Before removing each piston pin, deburr the clip groove and pin hole area. If the piston pin groove is deburred and the piston pin is still difficult to remove, use the piston pin puller ④.



**Piston pin puller:**  
P/N. YU-01304, 90890-01304

**CAUTION:**

**Do not use a hammer to drive the piston pin out.**

2.Remove:

- Piston rings

**NOTE:**

Spread the end gaps apart while at the same time lifting the piston ring over the top of the piston crown, as shown in the illustration.

**CHECKING THE CYLINDER AND PISTON**

1.Check:

- Cylinder and piston walls  
Vertical scratches → Rebore or replace the cylinder and the piston.

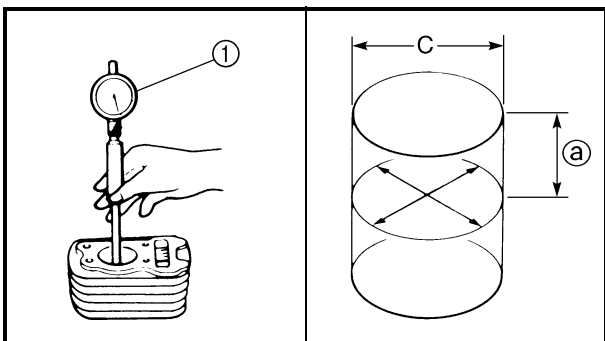

2.Measure:

- Piston-to-cylinder clearance

\*\*\*\*\*

**Measurement steps:**

**1st step:**

- Measure the cylinder bore “C” with a cylinder bore gauge ①.
- ② 50 mm (2.0 in) from the top of the cylinder

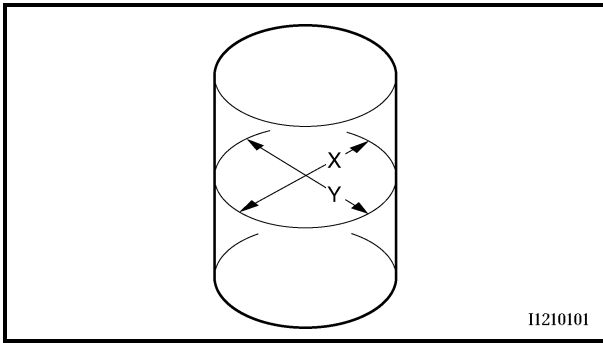

11210101

**NOTE:** \_\_\_\_\_  
 Measure cylinder bore “C” in parallel to and at right angles to the cylinder matching surface. Then, find the average of the measurements.

	<b>Standard</b>	<b>Wear limit</b>
<b>Cylinder bore “C”</b>	<b>100.005 ~ 100.045 mm (3.9372 ~ 3.9388 in)</b>	<b>100.100 mm (3.9404 in)</b>
$C = \frac{X+Y}{2}$		

● If out of specification, rebore or replace the cylinder, and replace the piston and piston rings as a set.

**2nd step:**

- Measure piston skirt diameter “P” with a micrometer.
- ⓑ 5.0 mm (0.20 in) from the piston bottom edge

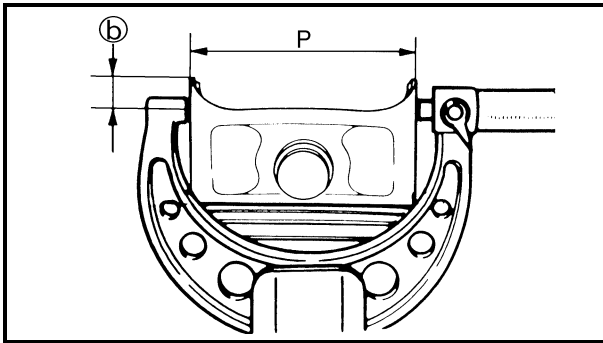

	<b>Piston skirt diameter “P”:</b>	
<b>Standard</b>	<b>99.945 ~ 99.995 mm (3.9348 ~ 3.9368 in)</b>	

● If out of specification, replace the piston and piston rings as a set.

**3rd step:**

- Find the piston-to-cylinder clearance with the following formula.

<p><b>Piston-to-cylinder clearance =</b>  <b>Cylinder bore “C” –</b>  <b>Piston skirt diameter “P”</b></p>
--

	<p><b>Piston-to-cylinder clearance:</b>  <b>0.05 ~ 0.07 mm</b>  <b>(0.0020 ~ 0.0028 in)</b>  <b>&lt;Limit&gt;: 0.15 mm (0.0059 in)</b></p>
--	--

● If out of specification, rebore or replace the cylinder, and replace the piston and piston rings as a set.

\*\*\*\*\*

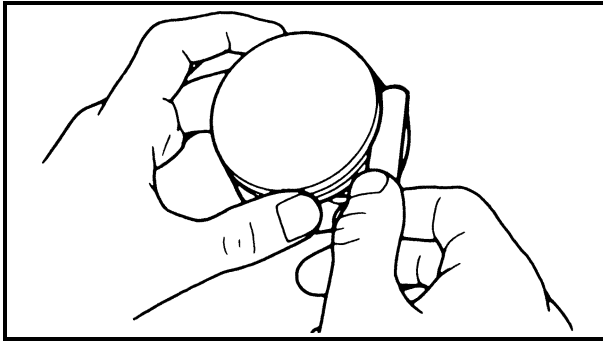

### CHECKING THE PISTON RING

1. Measure:

- Ring side clearance  
Use a feeler gauge.  
Out of specification → Replace the piston and rings as a set.

**NOTE:** \_\_\_\_\_

Clean carbon from the piston ring grooves and rings before measuring the side clearance.

	Side clearance	
	Standard	Limit
<b>Top ring</b>	<b>0.04 ~ 0.08 mm (0.0016 ~ 0.0031 in)</b>	<b>0.13 mm (0.0051 in)</b>
<b>2nd ring</b>	<b>0.03 ~ 0.07 mm (0.0012 ~ 0.0028 in)</b>	<b>0.13 mm (0.0051 in)</b>

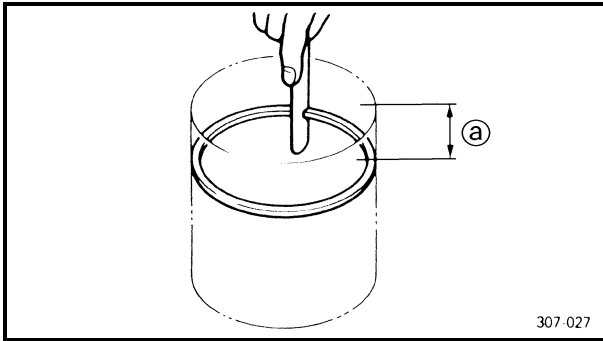

2. Position:

- Piston ring  
(in cylinder)

**NOTE:** \_\_\_\_\_

Insert a ring into the cylinder and push it approximately 50 mm (2.0 in) into the cylinder. Push the ring with the piston crown so that the ring will be at a right angle to the cylinder bore.

Ⓐ 50 mm (2.0 in)

3. Measure:

- Ring end gap  
Out of specification → Replace.

**NOTE:** \_\_\_\_\_

You cannot measure the end gap on the expander spacer of the oil control ring. If the oil control ring rails show excessive gap, replace all three rings.

	End gap	
	Standard	Limit
<b>Top ring</b>	<b>0.30 ~ 0.45 mm (0.0118 ~ 0.0177 in)</b>	<b>0.70 mm (0.0276 in)</b>
<b>2nd ring</b>	<b>0.30 ~ 0.45 mm (0.0118 ~ 0.0177 in)</b>	<b>0.80 mm (0.0315 in)</b>
<b>Oil ring</b>	<b>0.2 ~ 0.7 mm (0.0079 ~ 0.0276 in)</b>	—



**CHECKING THE PISTON PIN INSPECTION**

1. Check:

- Piston pin  
Blue discoloration/grooves → Replace, then inspect the lubrication system.

2. Measure:

- Piston pin-to-piston clearance

\*\*\*\*\*

**Measurement steps:**

- Measure the piston pin outside diameter (a).  
If out of specification, replace the piston pin.

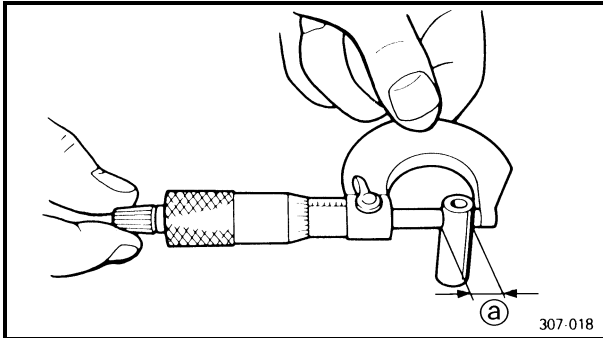

	<b>Outside diameter (piston pin):</b> 21.991 ~ 22.000 mm (0.8658 ~ 0.8661 in)
--	---

- Measure the piston inside diameter (b).

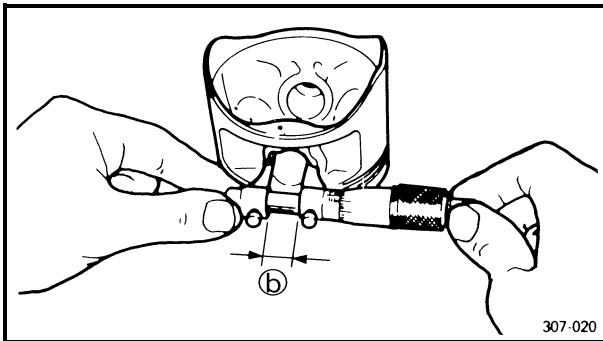

	<b>Piston pin bore inside diameter:</b> 22.004 ~ 22.015 mm (0.8663 ~ 0.8667 in)
--	---

- Calculate the piston pin-to-piston clearance with the following formula.

<b>Piston pin-to-piston clearance =</b> <b>Bore size (piston pin) (b) –</b> <b>Outside diameter (piston pin) (a)</b>
--

- If out of specification, replace the piston.

	<b>Piston pin-to-piston clearance:</b> 0.004 ~ 0.024 mm (0.00016 ~ 0.00094 in) <Limit>: 0.07 mm (0.003 in)
--	---

\*\*\*\*\*

**INSTALLING THE PISTON**

1. Install:

- Piston rings  
(onto the piston)

**NOTE:**

- Be sure to install the piston rings so that the manufacturer's marks or numbers are located on the upper side of the rings.
- Lubricate the piston and piston rings liberally with engine oil.

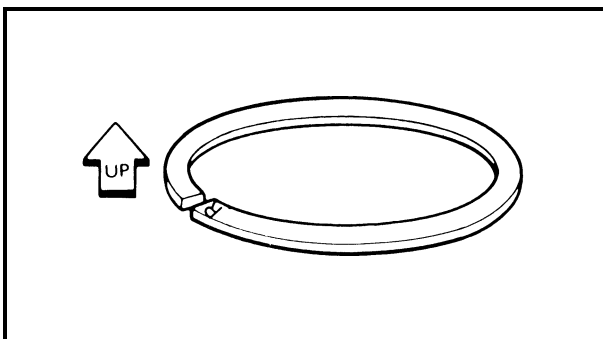



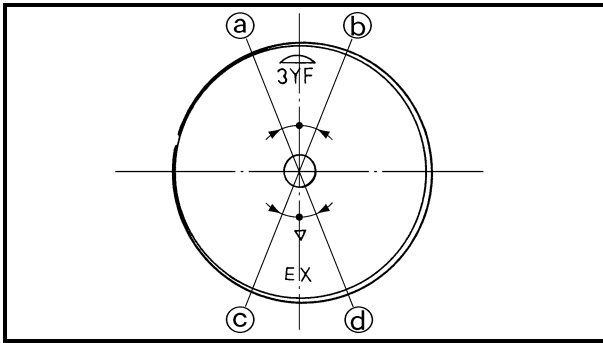

### 2.Position:

- Top ring
- 2nd ring
- Oil ring

Offset the piston ring end gaps as shown.

- Ⓐ Top ring end
- Ⓑ Oil ring end (lower)
- Ⓒ Oil ring end (upper)
- Ⓓ 2nd ring end

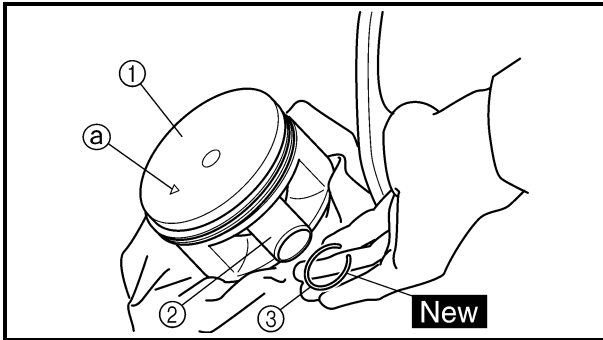

### 3.Install:

- Piston ①
- Piston pin ②
- Piston pin clips ③ **New**

### NOTE:

- Apply engine oil onto the piston pin, piston ring and piston.
- Be sure that the arrow mark Ⓐ on the piston points to the exhaust side of the engine.
- Before installing the piston pin clip, cover the crankcase with a clean rag to prevent the piston pin clip from falling into the crankcase.

### 4.Lubricate:

- Piston
- Piston rings
- Cylinder

### NOTE:

Apply a liberal coating of engine oil.

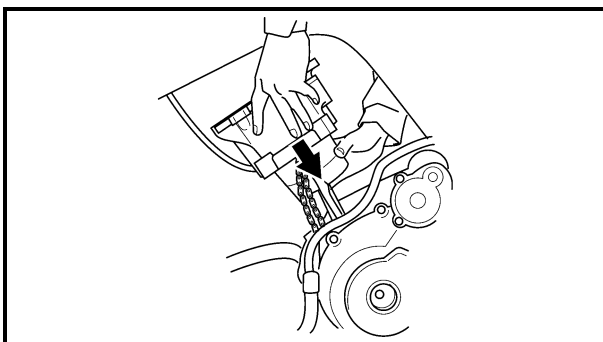

## INSTALLING THE CYLINDER

### 1.Install:

- Cylinder
- O-ring **New**
- Bolts (M10)
- Bolts (M6)

	<b>42 Nm (4.2 m · kg, 30 ft · lb)</b>
--	---------------------------------------

	<b>10 Nm (1.0 m · kg, 7.2 ft · lb)</b>
--	--

### NOTE:

Install the cylinder with one hand while compressing the piston rings with the other hand.

### CAUTION:

- Be careful not to damage the timing chain damper during installation.
- Pass the timing chain through the timing chain cavity.



AC MAGNETO

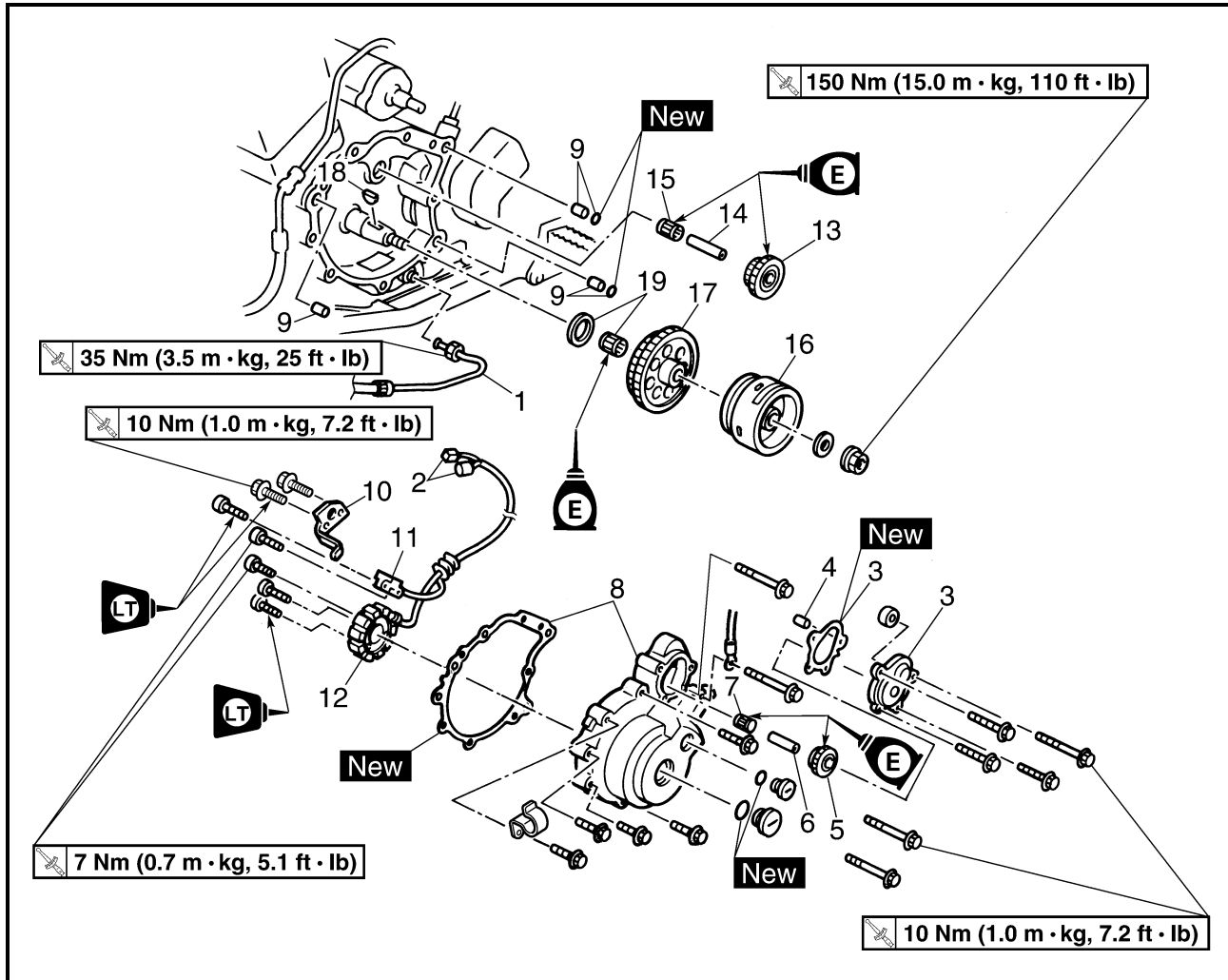

Order	Job name/Part name	Q'ty	Remarks
	<b>Removing the AC magneto</b>		Remove the parts in the order below.
	Engine oil		Drain.
	Shift pedal link		Disconnect.
1	Oil pipe 1	1	Disconnect.
2	AC magneto coupler	2	
3	Starter idle gear cover/gasket	1/1	
4	Dowel pin	1	
5	Starter idle gear 1	1	
6	Starter idle gear 1 shaft	1	
7	Bearing	1	
8	AC magneto cover/gasket	1/1	Refer to "REMOVING/INSTALLING THE AC MAGNETO ROTOR".

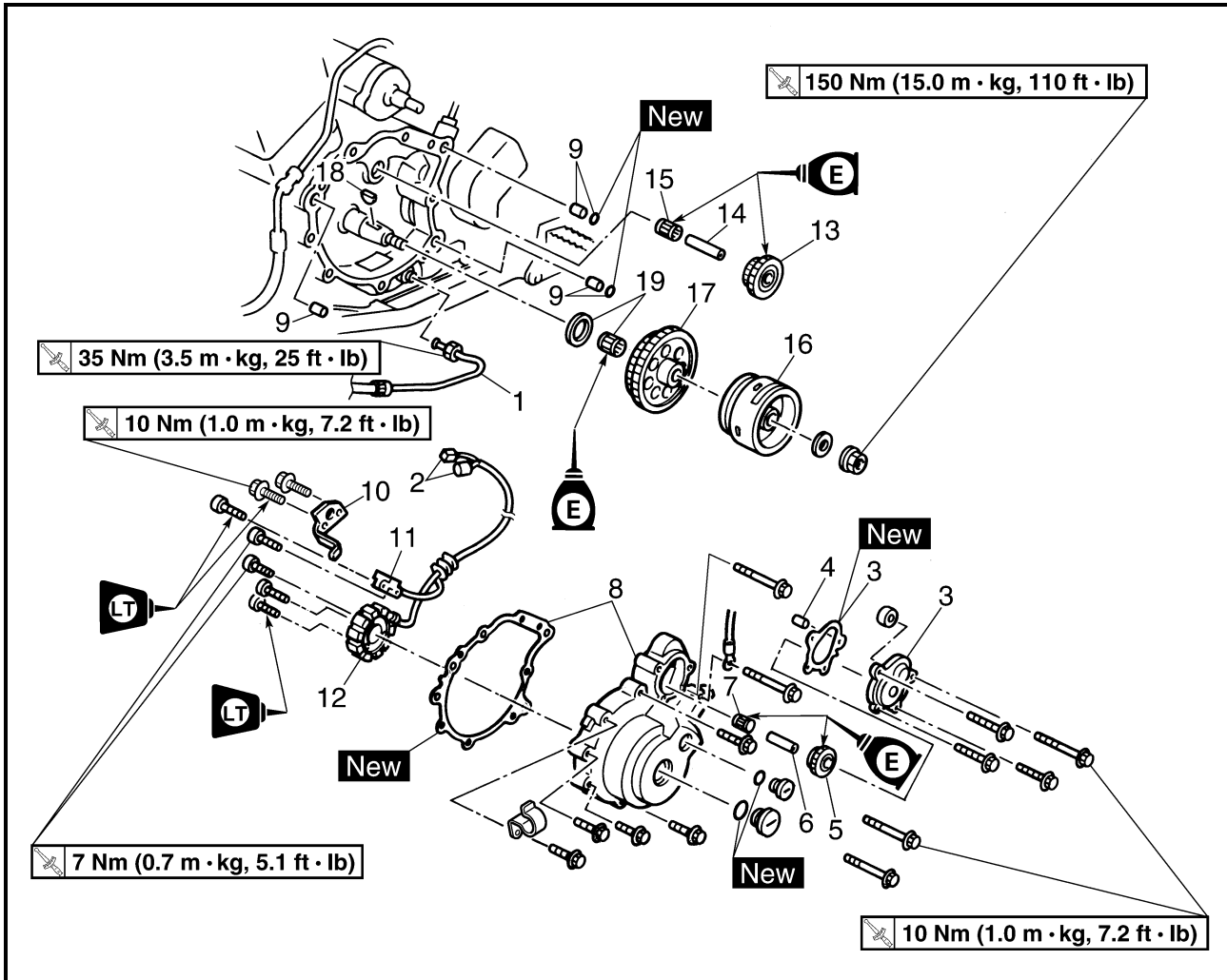

Order	Job name/Part name	Q'ty	Remarks
9	Dowel pin/O-ring	3/2	
10	Lead holder	1	
11	Pickup coil	1	
12	Stator assembly	1	
13	Starter idle gear 2	1	
14	Starter idle gear 2 shaft	1	
15	Bearing	1	
16	AC magneto rotor	1	Refer to "REMOVING/INSTALLING THE AC MAGNETO ROTOR".
17	Starter wheel gear	1	
18	Woodruff key	1	
19	Bearing/washer	1/1	For installation, reverse the removal procedure.

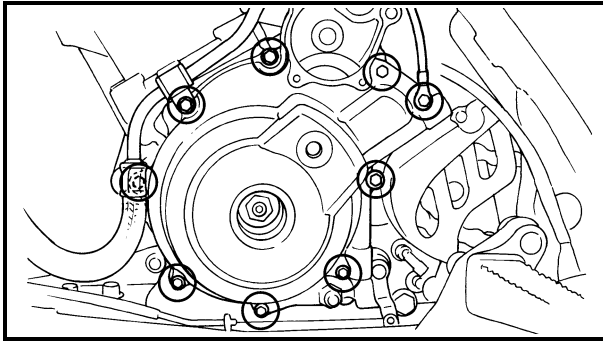
**REMOVING THE AC MAGNETO ROTOR**

1.Remove:

- AC magneto cover

**NOTE:**

Loosen each bolt 1/4 of a turn at a time, in stages and in a crisscross pattern. After all of the bolts are fully loosened, remove them.

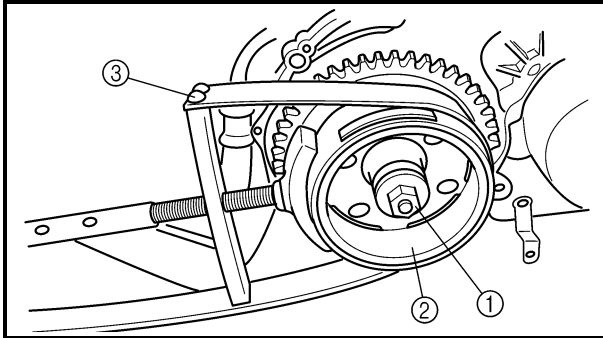

2.Remove:

- AC magneto rotor nut ①
- Washer

**NOTE:**

- While holding the AC magneto rotor ② with the sheave holder ③, loosen the generator rotor nut.
- Do not allow the sheave holder to touch the projection ④ on the rotor.

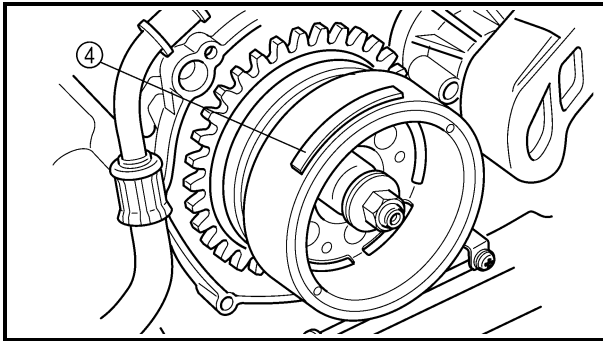
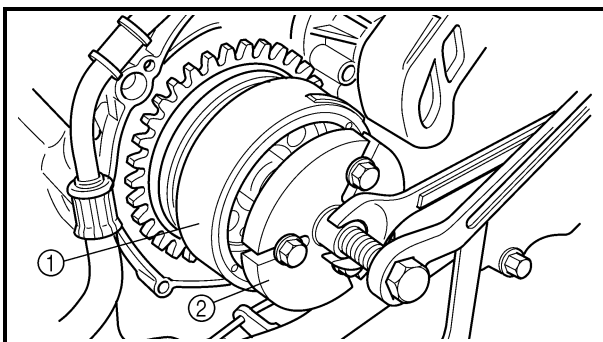
**Sheave holder:****P/N. YS-01880, 90890-01701**

3.Remove:

- AC magneto rotor ①

**NOTE:**

Use the flywheel puller ②.

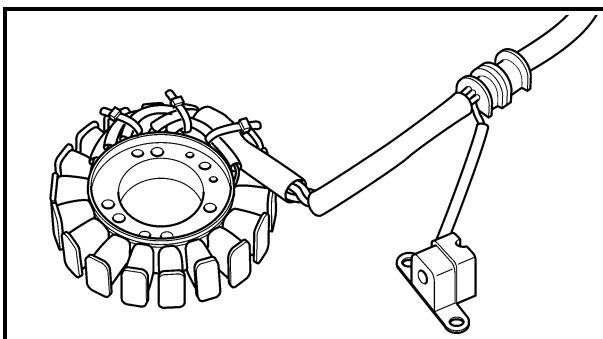
**Flywheel puller:****P/N. YU-33270, 90890-01362****CHECKING THE COIL**

1.Check:

- Stator assembly
- Pickup coil
- Damage → Replace.

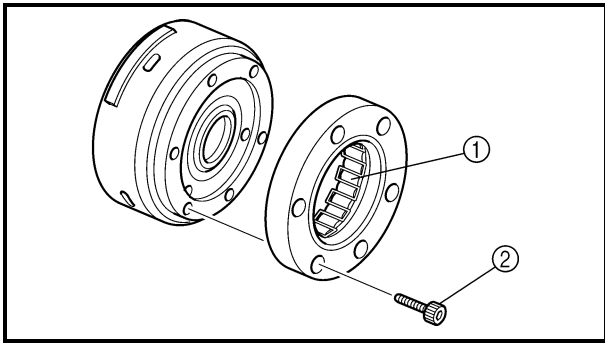

**CHECKING THE STARTER CLUTCH**

1.Check:

- Starter one-way clutch ①  
Cracks/damage → Replace.
- Bolts ② (starter clutch)  
Loose → Replace.

**NOTE:**

The arrow mark on the starter clutch must face inward, away from the AC magneto rotor.



**Bolts (starter clutch):**  
**16 Nm (1.6 m • kg, 11 ft • lb)**  
**LOCTITE®**

\*\*\*\*\*

**Checking steps:**

- Install the starter wheel gear to the starter clutch, and hold the starter clutch.
- When turning the starter wheel gear counter clockwise **A**, the starter clutch and the wheel gear should be engaged.  
If not, the starter clutch is faulty. Replace it.
- When turning the starter wheel gear clockwise **B**, the starter wheel gear should turn freely.  
If not, the starter clutch is faulty. Replace it.

\*\*\*\*\*

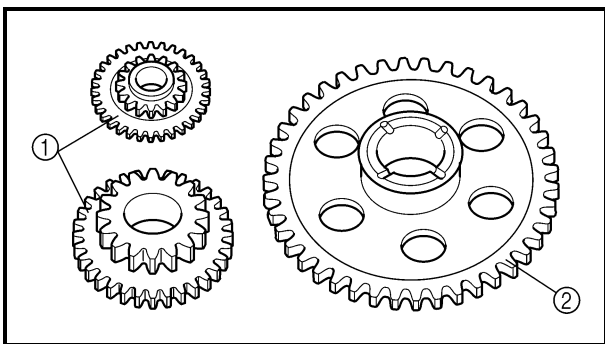
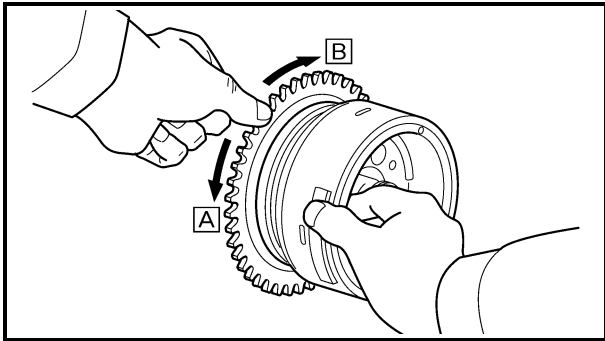

2.Check:

- Gear teeth (starter idle) ①
- Gear teeth (starter wheel) ②  
Burrs/chips/roughness/wear → Replace.

3.Check:

- Starter wheel gear  
(contacting surface)  
Damage/pitting/wear → Replace.

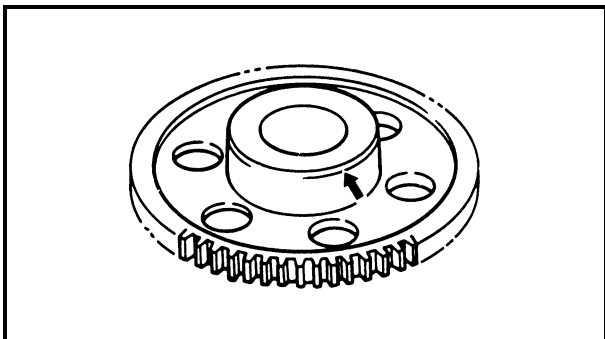

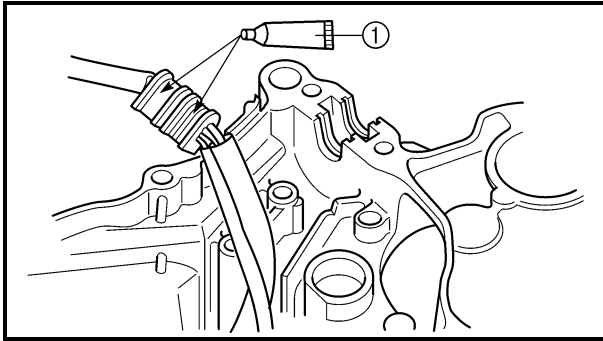
**INSTALLING THE AC MAGNETO ROTOR****1. Apply:**

- Sealant (Quick Gasket®) ①  
(into the slit)



**Sealant (Quick Gasket®):**  
P/N. ACC-11001-05-01  
**Yamaha bond No. 1215®:**  
P/N. 90890-85505

**2. Install:**

- Woodruff key
- AC magneto rotor

**NOTE:**

- Before installing the rotor, clean the outside of the crankshaft and the inside of the rotor.
- After installing the rotor, check that the rotor rotates smoothly. If not, reinstall the key and rotor.

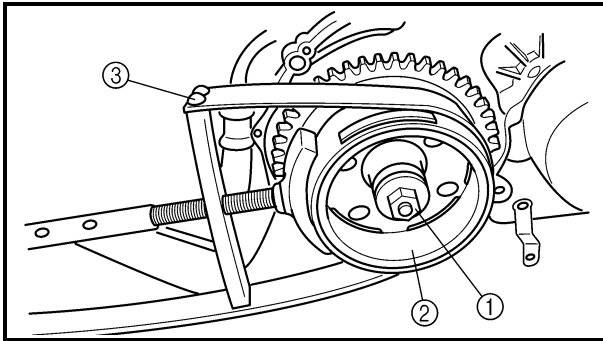
**3. Tighten:**

- AC magneto rotor nut ①

**150 Nm (15.0 m • kg, 110 ft • lb)**

**NOTE:**

- While holding the AC magneto rotor ② with the sheave holder ③, tighten the generator rotor nut.
- Do not allow the sheave holder to touch the projection ④ on the rotor.

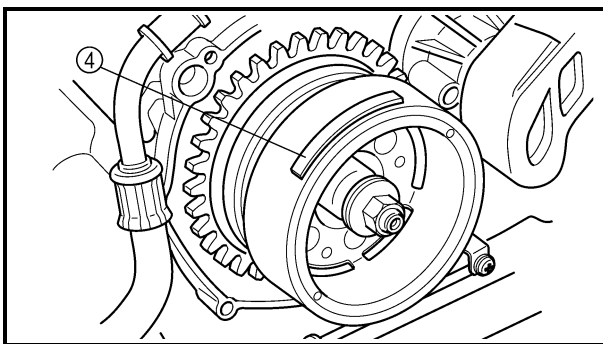

**Sheave holder:**  
P/N. YS-01880, 90890-01701

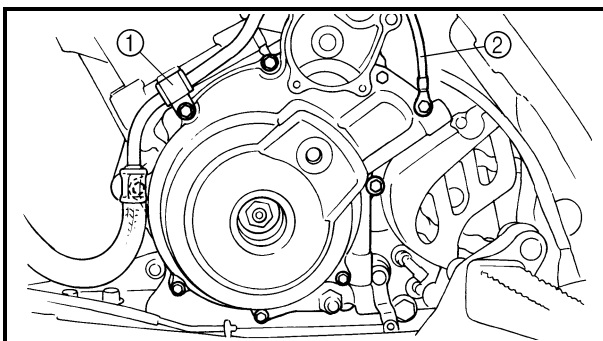
**4. Install:**

- AC magneto cover
- Oil pipe holder ①
- Ground lead ②
- Bolts

**10 Nm (1.0 m • kg, 7.2 ft • lb)**

**NOTE:**

Tighten the AC magneto cover bolts in stages, using a crisscross pattern.



CLUTCH

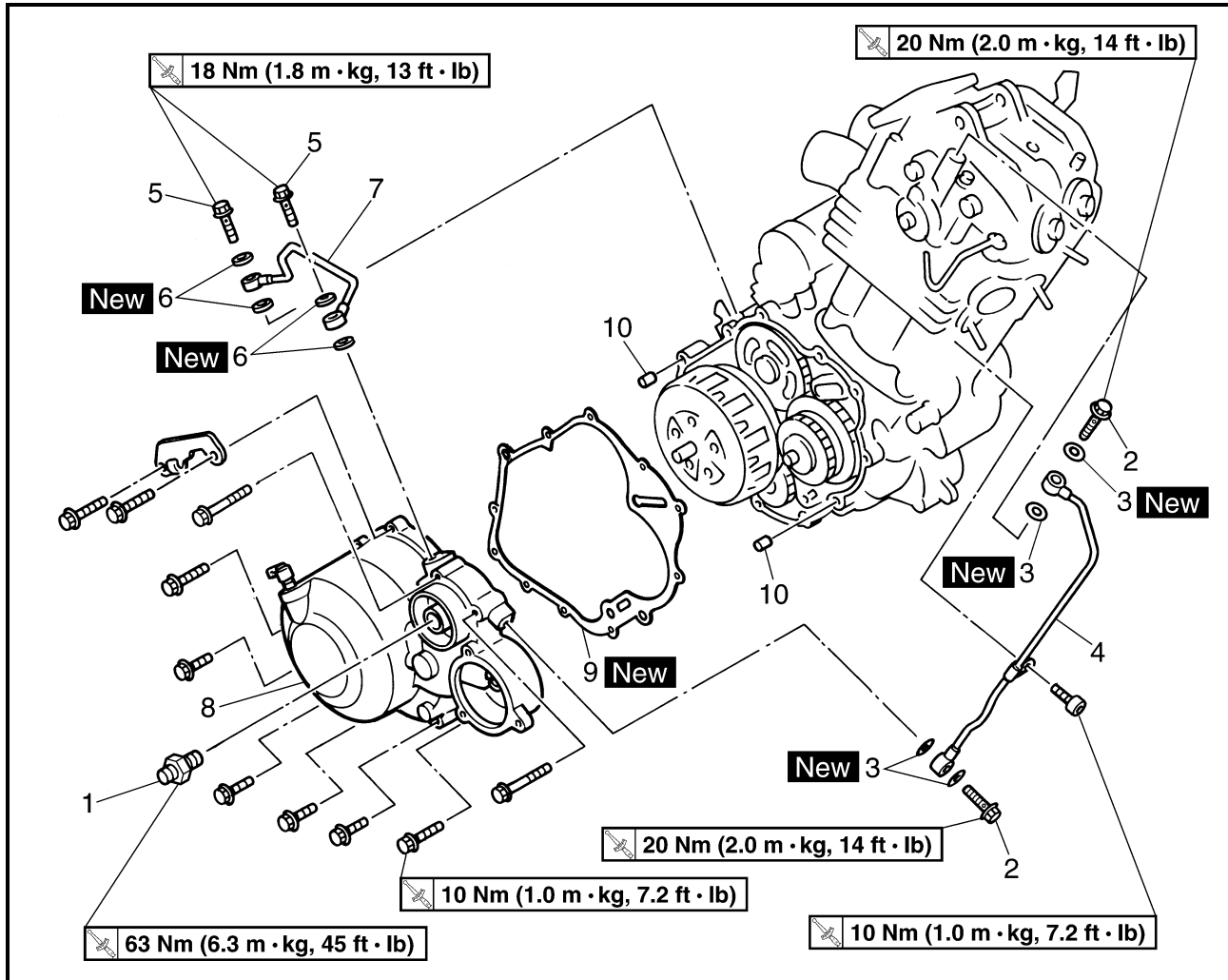

Order	Job name/Part name	Q'ty	Remarks
	<b>Removing the clutch cover</b>		
	Engine assembly		Remove the parts in the order below. Refer to "ENGINE REMOVAL".
1	Oil filter bolt	1	
2	Union bolt	2	
3	Copper washer	4	
4	Oil delivery pipe 1	1	
5	Union bolt	2	
6	Copper washer	4	
7	Oil delivery pipe 2	1	
8	Clutch cover	1	Refer to "REMOVING/INSTALLING THE CLUTCH".
9	Clutch cover gasket	1	
10	Dowel pin	2	
			For installation, reverse the removal procedure.

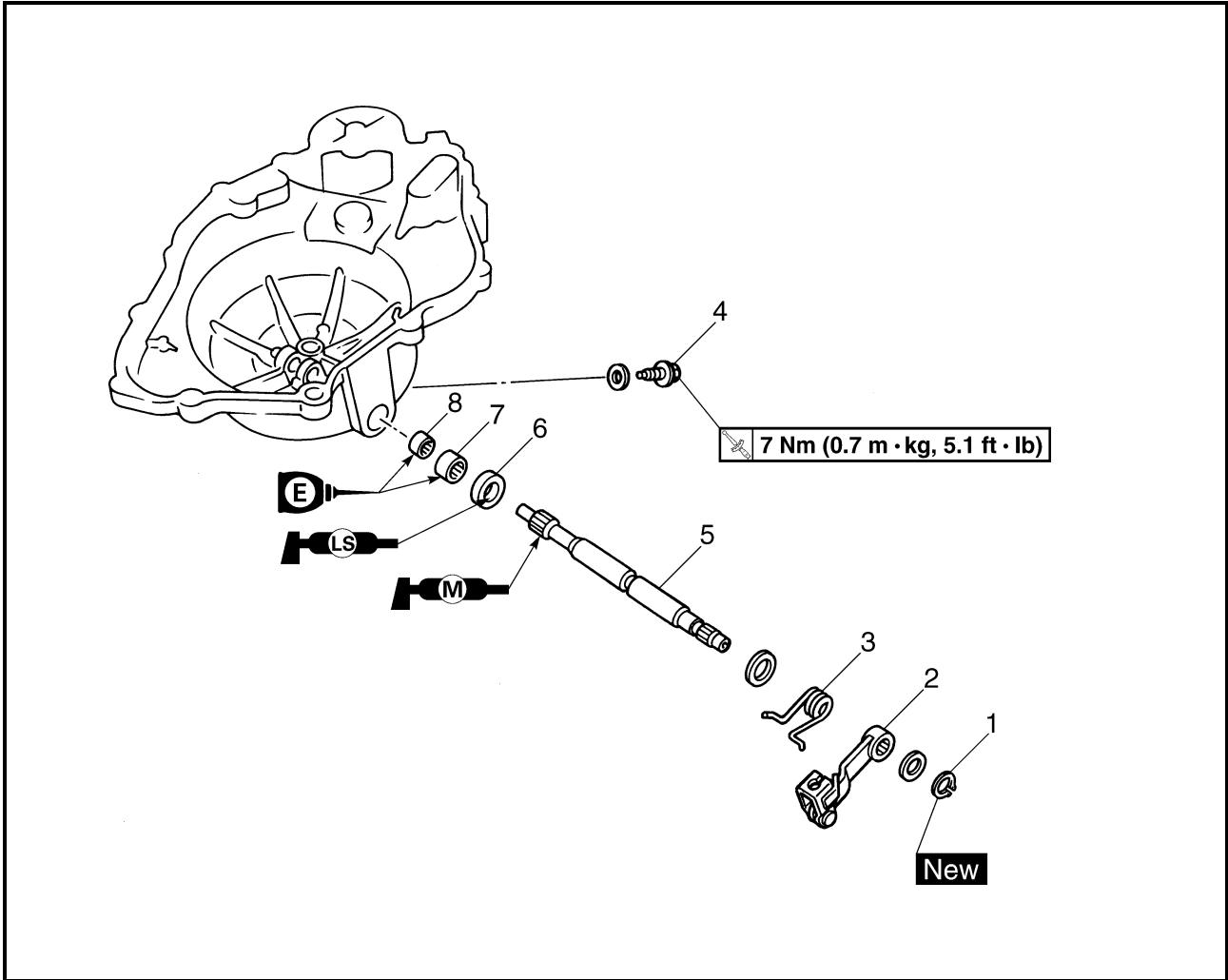

Order	Job name/Part name	Q'ty	Remarks
	<b>Removing the pull lever shaft</b>		Remove the parts in the order below.
1	Circlip	1	
2	Pull lever	1	
3	Pull lever spring	1	
4	Bolt	1	
5	Pull lever shaft	1	
6	Oil seal	1	
7	Bearing	1	
8	Bearing	1	
			For installation, reverse the removal procedure.



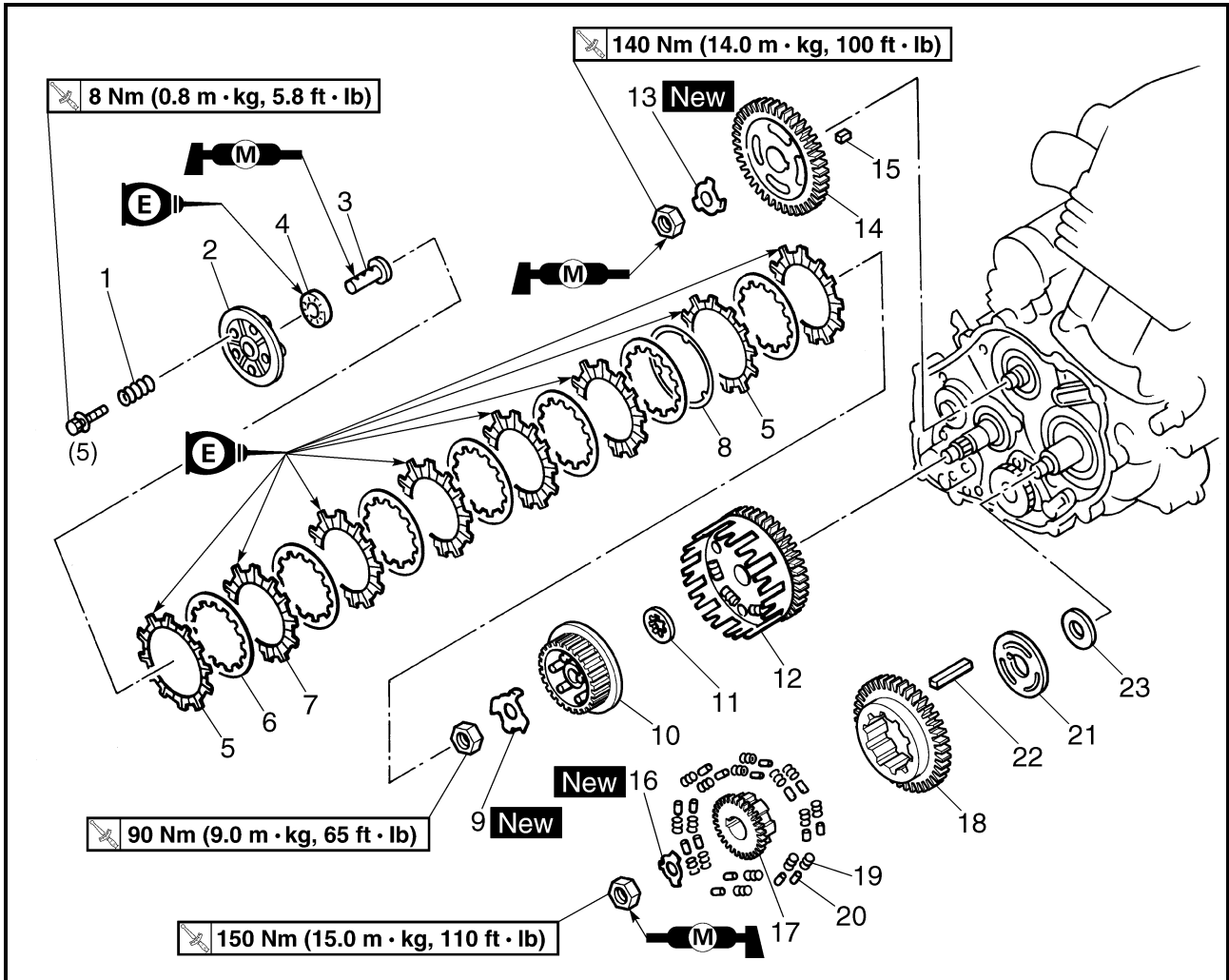

Order	Job name/Part name	Q'ty	Remarks	
	<b>Removing the clutch</b>		Remove the parts in the order below.	
1	Clutch spring	5	Refer to "INSTALLING THE CLUTCH".	
2	Pressure plate	1		
3	Pull rod	1		
4	Bearing	1		
5	Friction plate 2	2		Inside diameter = 116 mm (4.57 in)
6	Clutch plate	7		Inside diameter = 112 mm (4.41 in)
7	Friction plate 1	6		
8	Cushion spring	1		
9	Lock washer	1		
10	Clutch boss	1		

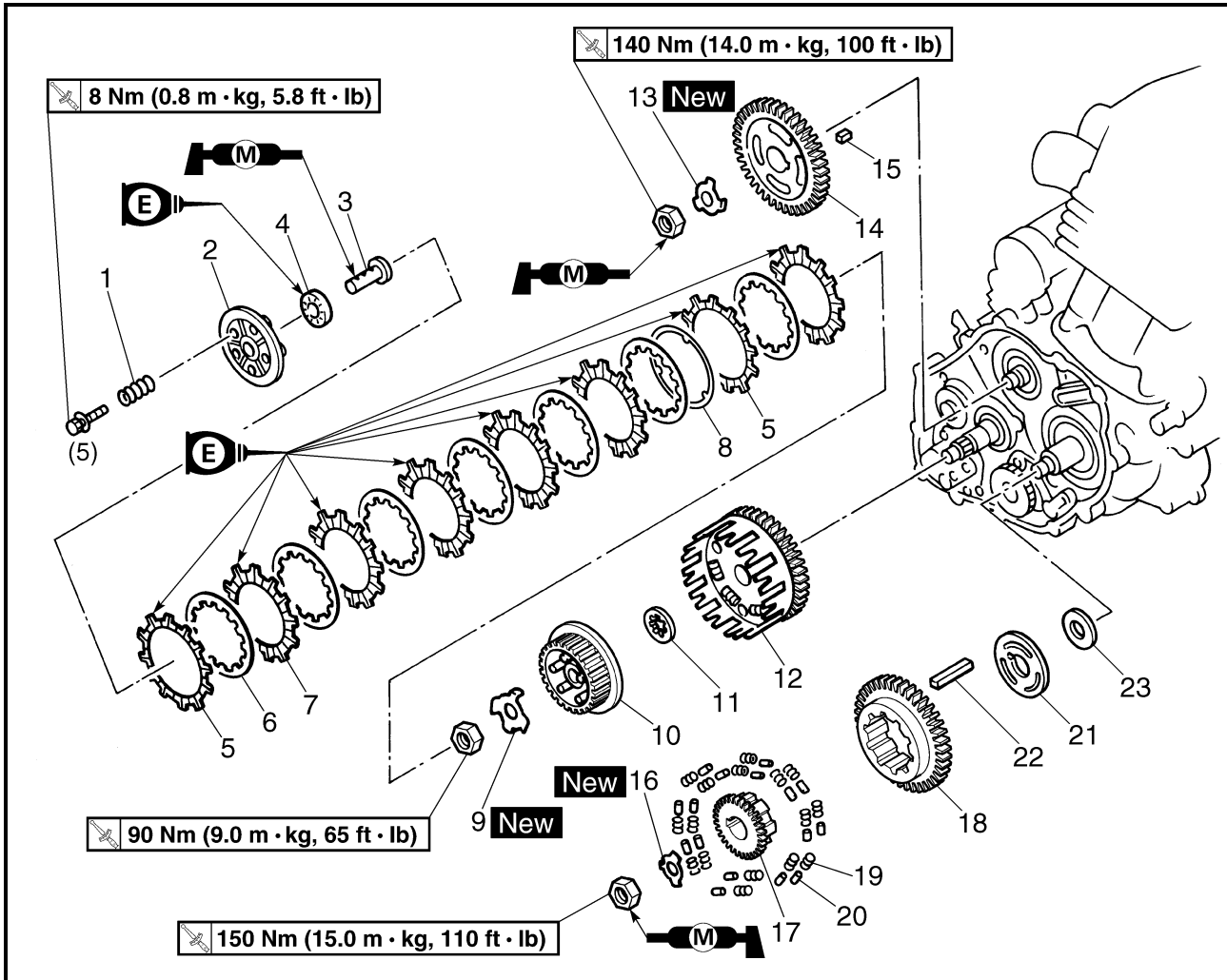

Order	Job name/Part name	Q'ty	Remarks
11	Thrust washer	1	
12	Clutch housing	1	Refer to "INSTALLING THE CLUTCH".
13	Lock washer	1	
14	Balancer driven gear	1	
15	Straight key	1	
16	Lock washer	1	Refer to "REMOVING/INSTALLING THE PRIMARY DRIVE GEAR AND BALANCER DRIVEN GEAR".
17	Primary drive gear	1	
18	Balancer drive gear	1	
19	Spring	16	
20	Dowel pin	16	
21	Plate	1	
22	Straight key	1	
23	Washer	1	
			For installation, reverse the removal procedure.

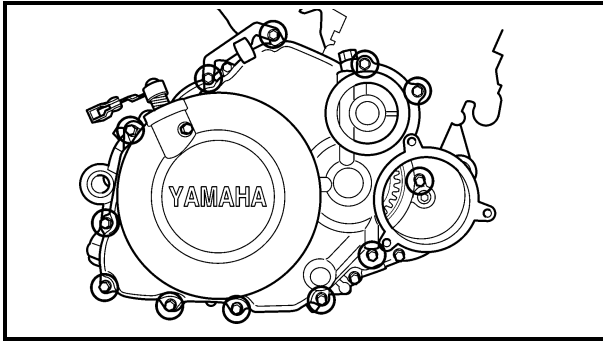

### REMOVING THE CLUTCH

1.Remove:

- Clutch cover

#### NOTE:

Loosen each bolt 1/4 of a turn at a time, in stages and in a crisscross pattern. After all of the bolts are fully loosened, remove them.

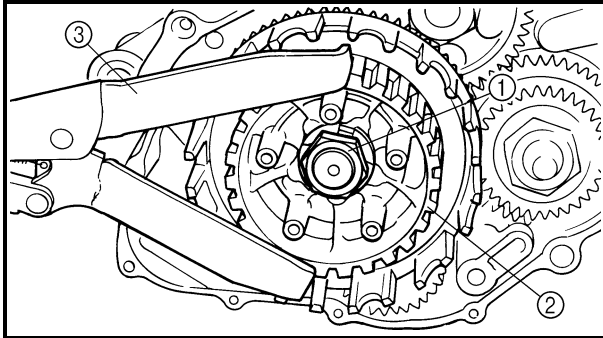

2.Straighten the lock washer tab.

3.Loosen:

- Clutch boss nut ①

#### NOTE:

While holding the clutch boss ② with the clutch holding tool ③, loosen the clutch boss nut.



**Clutch holding tool:**  
P/N. YM-91042, 90890-04086

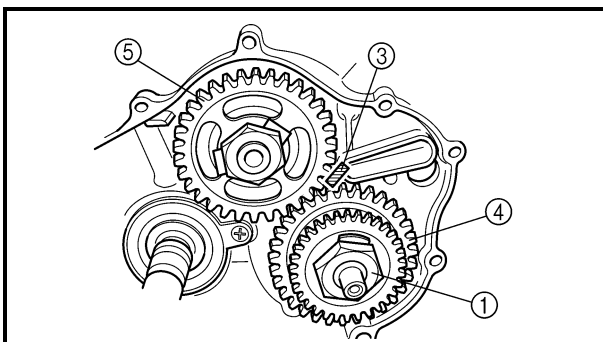

### REMOVING THE PRIMARY DRIVE GEAR AND BALANCER DRIVEN GEAR

1.Straighten the lock washer tabs.

2.Loosen:

- Primary drive gear nut ①
- Balancer driven gear nut ②

#### NOTE:

Place an aluminum plate ③ between the teeth of the balancer drive gear ④ and balancer driven gear ⑤.

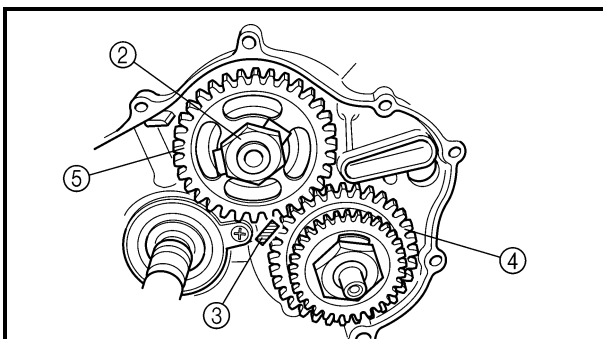



### CHECKING THE FRICTION PLATE

The following procedure applies to all of the friction plates.

#### 1.Check:

- Friction plate  
Damage/wear → Replace the friction plates as a set.

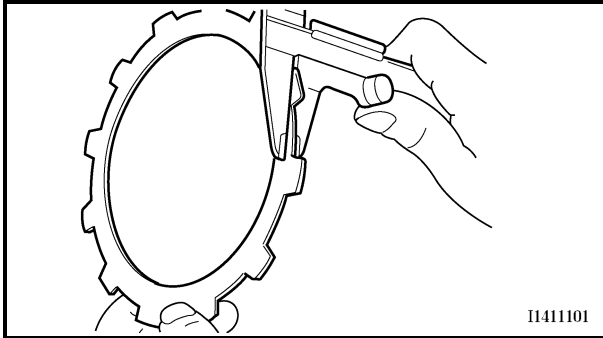

#### 2.Measure:

- Friction plate thickness  
Out of specification → Replace the friction plates as a set.

#### NOTE:

Measure the friction plate at four places.



#### Friction plate 1 thickness:

2.74 ~ 2.86 mm (0.108 ~ 0.113 in)

<Limit>: 2.6 mm (0.102 in)

#### Friction plate 2 thickness:

2.94 ~ 3.06 mm (0.116 ~ 0.120 in)

<Limit>: 2.8 mm (0.110 in)

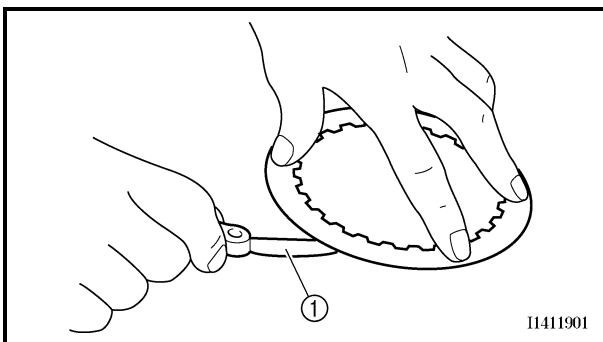

### CHECKING THE CLUTCH PLATE

The following procedure applies to all of the clutch plates.

#### 1.Check:

- Clutch plate  
Damage → Replace the clutch plates as a set.

#### 2.Measure:

- Clutch plate warpage  
(with a surface plate and thickness gauge ①)  
Out of specification → Replace the clutch plates as a set.



#### Maximum clutch plate warpage:

0.2 mm (0.008 in)



### CHECKING THE CLUTCH SPRING

The following procedure applies to all of the clutch springs.

#### 1. Check:

- Clutch spring  
Damage → Replace the clutch springs as a set.

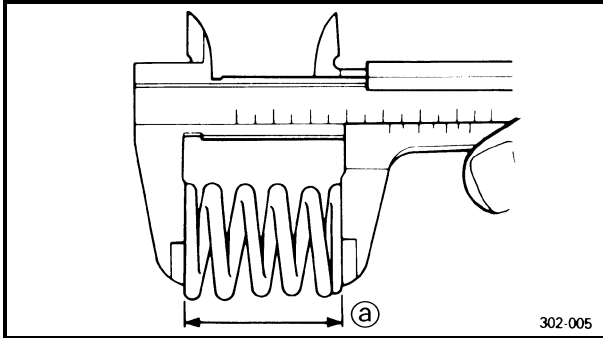

#### 2. Measure:

- Clutch spring free length <sup>Ⓐ</sup>  
Out of specification → Replace the clutch springs as a set.



**Clutch spring free length:**  
42.8 mm (1.69 in)  
<Limit>: 40.7 mm (1.60 in)

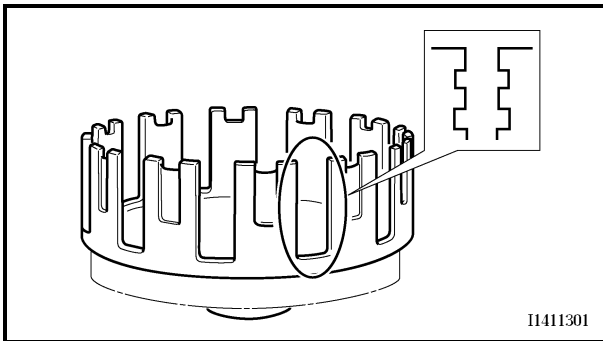

### CHECKING THE CLUTCH HOUSING

#### 1. Check:

- Clutch housing dogs  
Damage/pitting/wear → Deburr the clutch housing dogs or replace the clutch housing.

#### NOTE:

Pitting on the clutch housing dogs will cause erratic clutch operation.

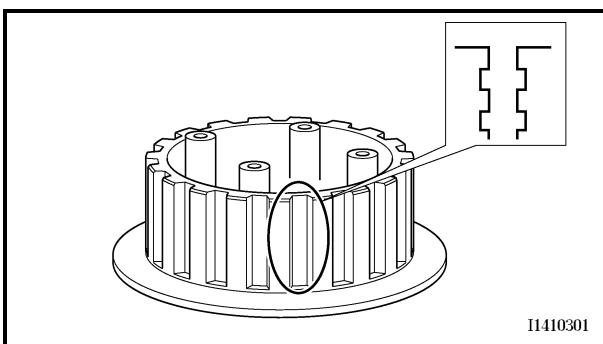

### CHECKING THE CLUTCH BOSS

#### 1. Check:

- Clutch boss splines  
Damage/pitting/wear → Replace the clutch boss.

#### NOTE:

Pitting on the clutch boss splines will cause erratic clutch operation.

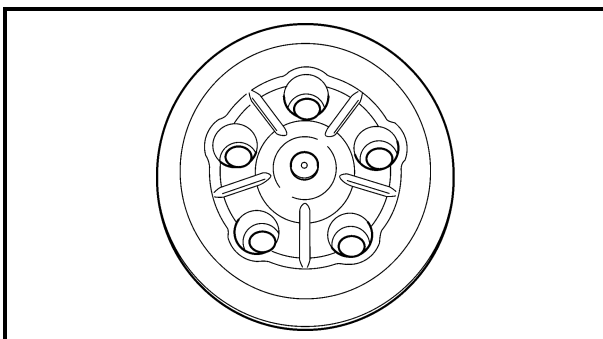

### CHECKING THE PRESSURE PLATE

#### 1. Check:

- Pressure plate  
Cracks/damage → Replace.

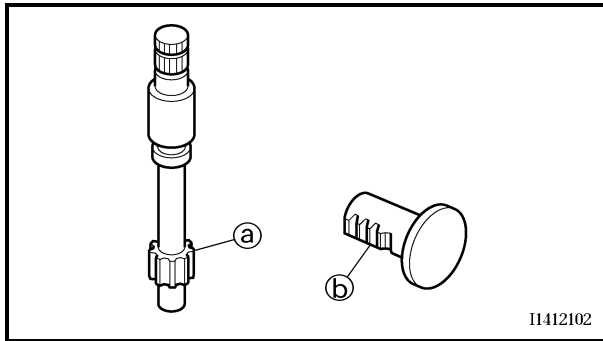

### CHECKING THE PULL LEVER SHAFT AND PULL ROD

#### 1.Check:

- Pull lever shaft pinion gear teeth ①
- Pull rod teeth ②  
Damage/wear → Replace the pull lever shaft and pull rod as a set.

#### 2.Check:

- Pull rod bearing  
Damage/wear → Replace.

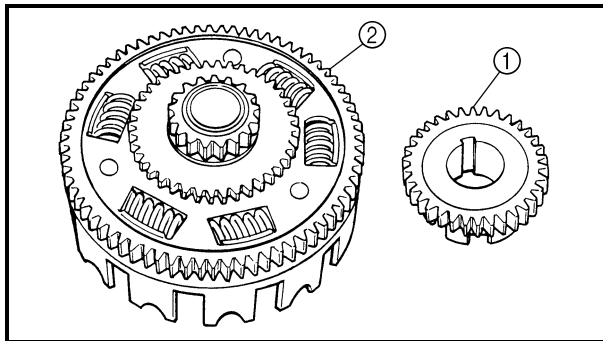

### CHECKING THE PRIMARY DRIVE

#### 1.Check:

- Primary drive gear ①
- Primary driven gear ②  
Damage/wear → Replace the primary drive gear and clutch housing as a set.  
Excessive noise during operation → Replace the primary drive gear and clutch housing as a set.

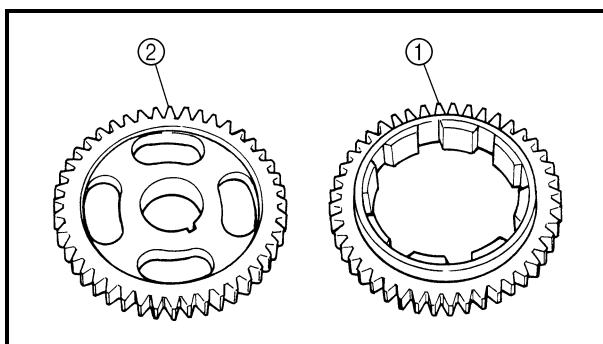

### CHECKING THE BALANCER DRIVE

#### 1.Check:

- Balancer drive gear ①
- Balancer driven gear ②  
Damage/wear → Replace the balancer drive gear and balancer driven gear as a set.  
Excessive noise during operation → Replace the balancer drive gear and balancer driven gear as a set.

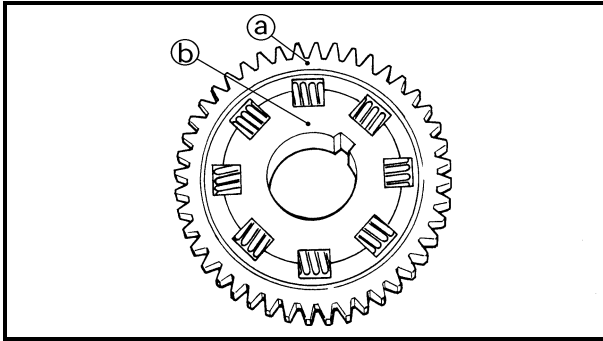

### INSTALLING THE PRIMARY DRIVE GEAR AND BALANCER DRIVEN GEAR

#### 1. Install:

- Dowel pin
- Spring
- Balancer drive gear  
(onto the primary drive gear)

#### NOTE:

Align the punch mark (a) on the balancer drive gear with the punch mark (b) on the primary drive gear.

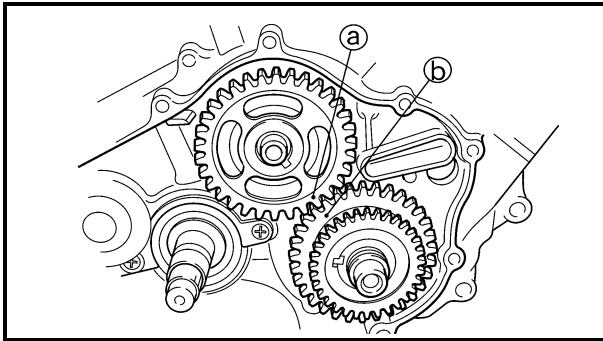

#### 2. Install:

- Primary drive gear
- Balancer driven gear

#### NOTE:

Align the punch mark (a) on the balancer driven gear with the punch mark (b) on the primary drive gear.

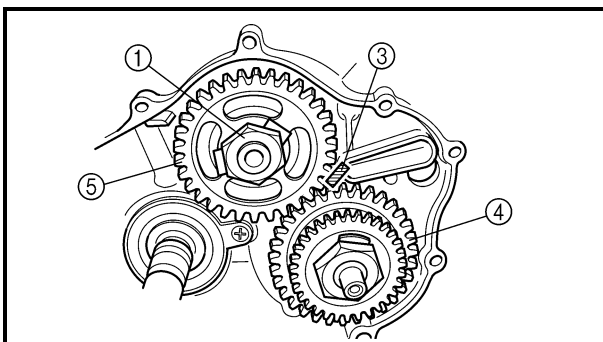

#### 3. Tighten:

- Balancer driven gear nut (1)

140 Nm (14.0 m • kg, 100 ft • lb)

- Primary drive gear nut (2)

150 Nm (15.0 m • kg, 110 ft • lb)

#### NOTE:

- Place an aluminum plate (3) between the teeth of the balancer drive gear (4) and balancer driven gear (5).
- Apply the molybdenum disulfide grease to the thread of axles and nuts.

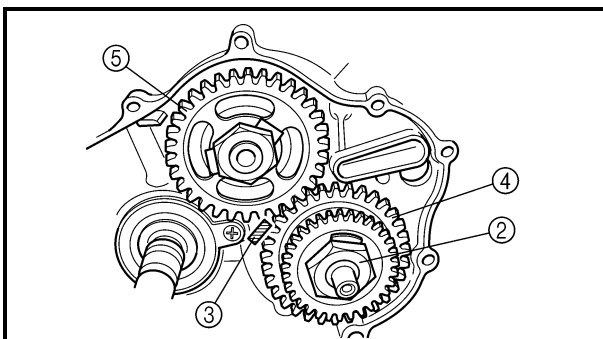

4. Bend the lock washer tabs along the balancer driven gear nut.

5. Bend the lock washer tabs along a flat side of the primary drive gear nut.

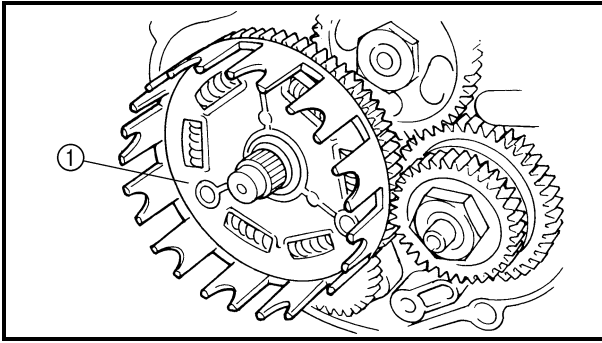

### INSTALLING THE CLUTCH

1. Install:

- Clutch housing ①

#### NOTE:

- Make sure that the primary driven gear teeth and primary drive gear teeth mesh correctly.
- Make sure that the oil pump drive gear teeth and oil pump driven gear teeth mesh correctly.

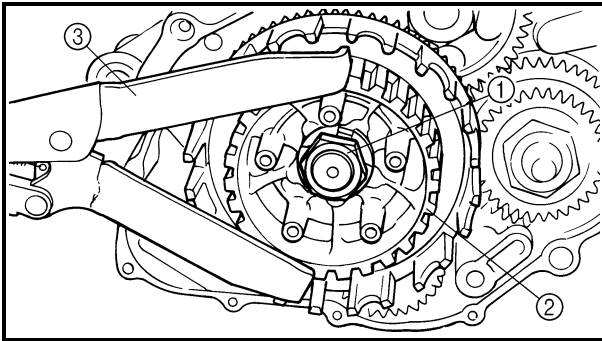

2. Tighten:

- Clutch boss nut ①

 90 Nm (9.0 m • kg, 65 ft • lb)

#### NOTE:

While holding the clutch boss ② with the clutch holding tool ③, tighten the clutch boss nut.



**Clutch holding tool:**  
P/N. YM-91042, 90890-04086

3. Bend the lock washer tab along a flat side of the nut.

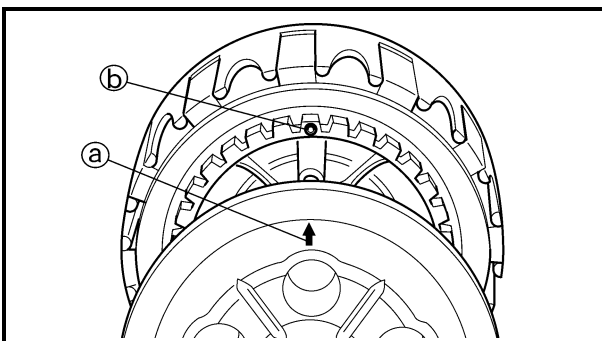

4. Install:

- Pressure plate ①

#### NOTE:

Align the punch mark ① on the pressure plate with the punch mark ② on the clutch boss.



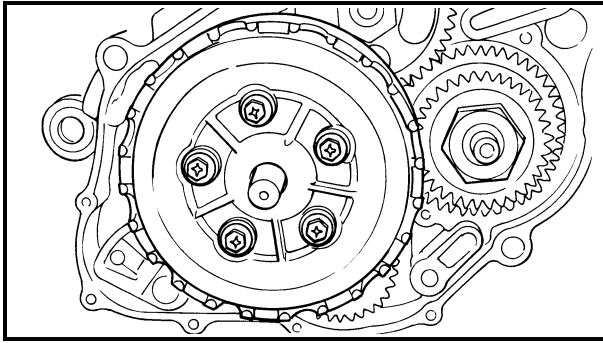

5. Install:

- Clutch spring  **8 Nm (0.8 m • kg, 5.8 ft • lb)**

**NOTE:** \_\_\_\_\_

Tighten the bolts in stages, using a crisscross pattern.

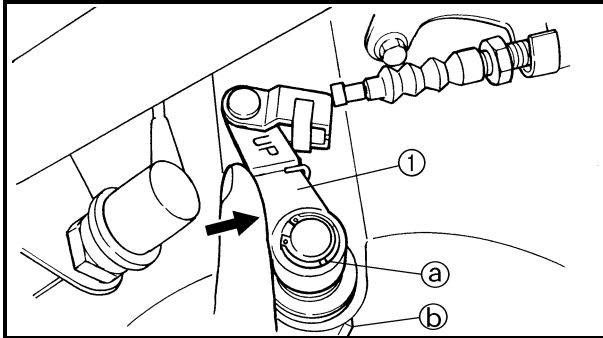

6. Install:

- Clutch cover

**NOTE:** \_\_\_\_\_

Be sure to mesh the pull lever shaft with the pull rod teeth to ensure that the mark **Ⓐ** on pull lever **①** is at the closest position to stationary pointer **Ⓑ** onto the clutch cover when the clutch is engaged.

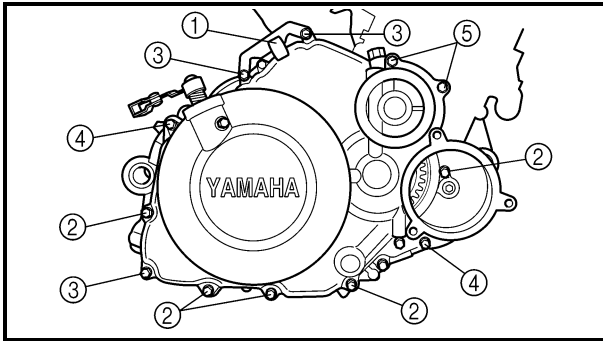

7. Install:

- Clutch cable holder **①**

- Bolts

 **10 Nm (1.0 m • kg, 7.2 ft • lb)**

- ② Bolt:  $l = 25$  mm
- ③ Bolt:  $l = 30$  mm
- ④ Bolt:  $l = 35$  mm
- ⑤ Bolt:  $l = 50$  mm

**NOTE:** \_\_\_\_\_

Tighten the bolts in stages, using a crisscross pattern.



OIL PUMP

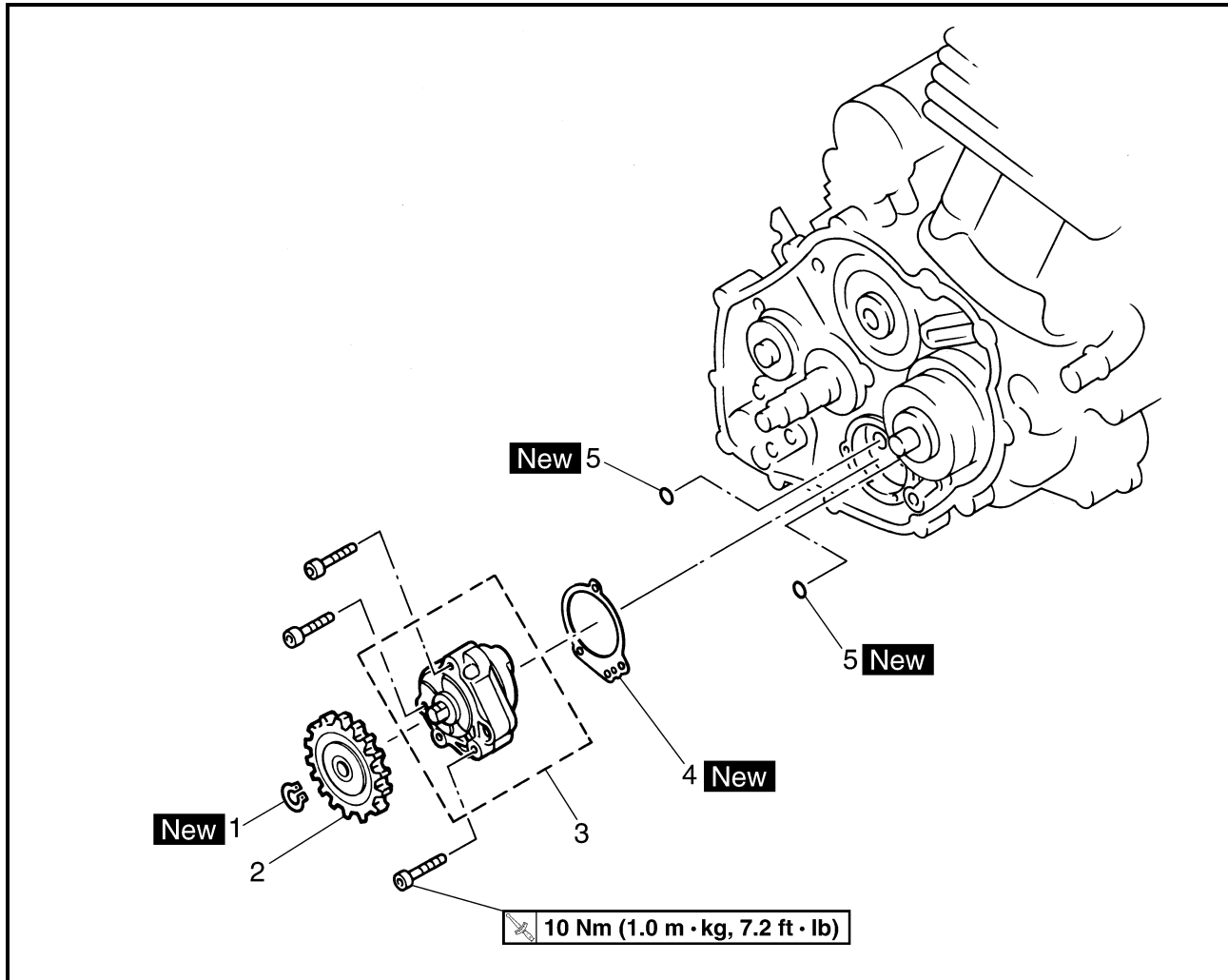

Order	Job name/Part name	Q'ty	Remarks
	<b>Removing the oil pump</b>		Remove the parts in the order below. Refer to "CLUTCH".
	Clutch		
1	Circlip	1	
2	Oil pump driven gear	1	
3	Oil pump	1	
4	Oil pump gasket	1	
5	O-ring	2	For installation, reverse the removal procedure.

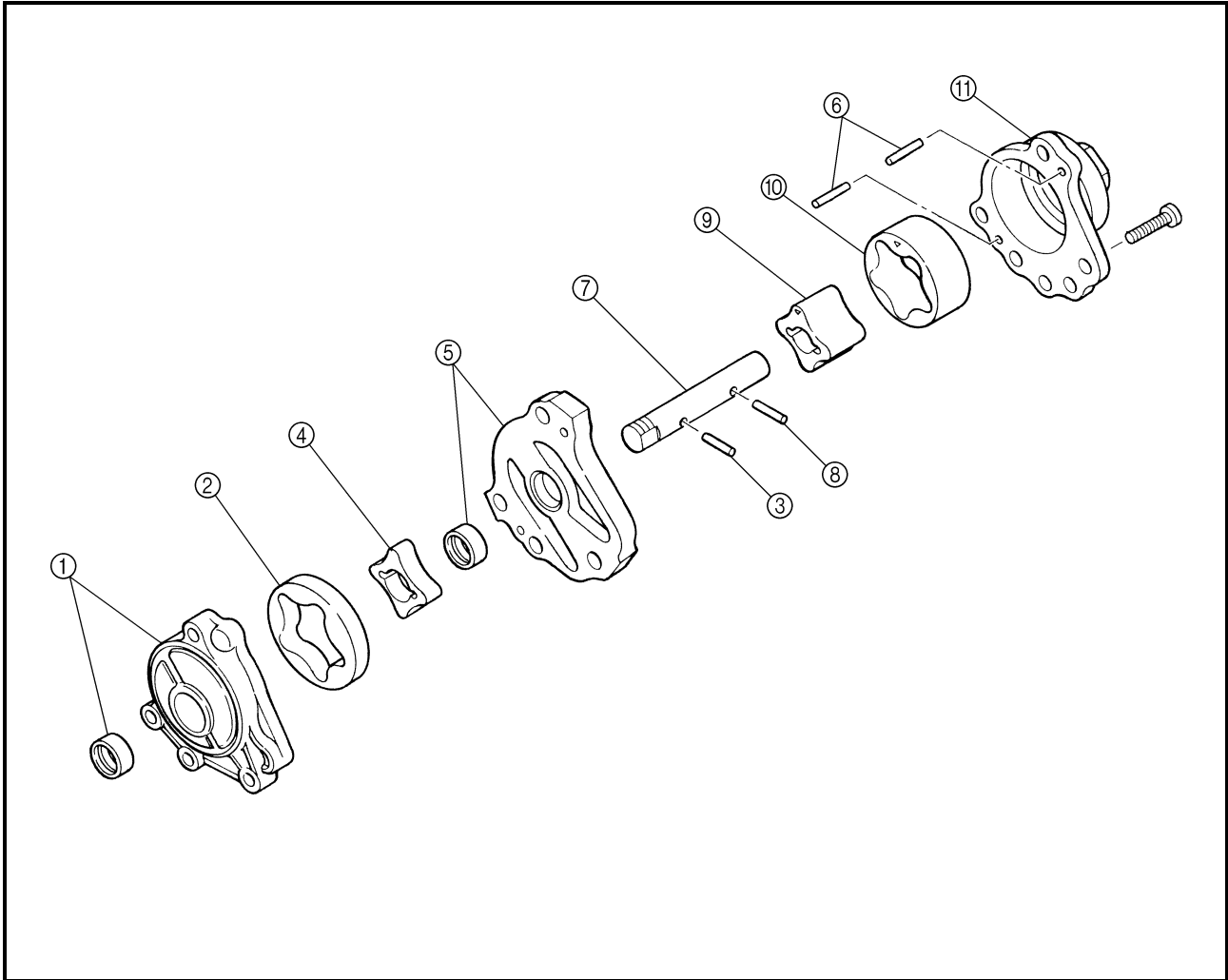

Order	Job name/Part name	Q'ty	Remarks
	<b>Disassembling the oil pump</b>		Remove the parts in the order below.
①	Oil pump housing 1/oil seal	1/1	
②	Oil pump outer rotor 1	1	
③	Dowel pin	1	
④	Oil pump inner rotor 1	1	
⑤	Oil pump housing cover/oil seal	1/1	
⑥	Dowel pin	2	
⑦	Oil pump shaft	1	
⑧	Dowel pin	1	
⑨	Oil pump inner rotor 2	1	Refer to "ASSEMBLING THE OIL PUMP".
⑩	Oil pump outer rotor 2	1	
⑪	Oil pump housing 2	1	
			For assembly, reverse the disassembly procedure.

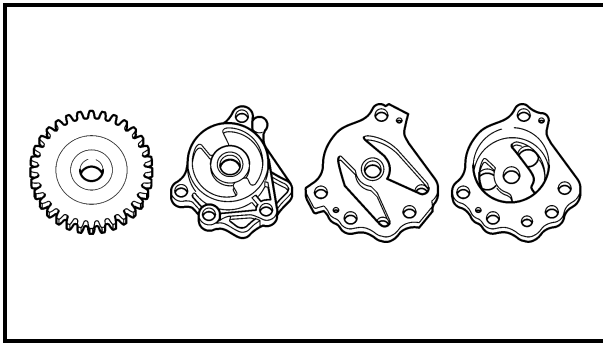

### CHECKING THE OIL PUMP

#### 1. Check:

- Oil pump driven gear
- Oil pump housings
- Oil pump housing cover
- Cracks/wear/damage → Replace.

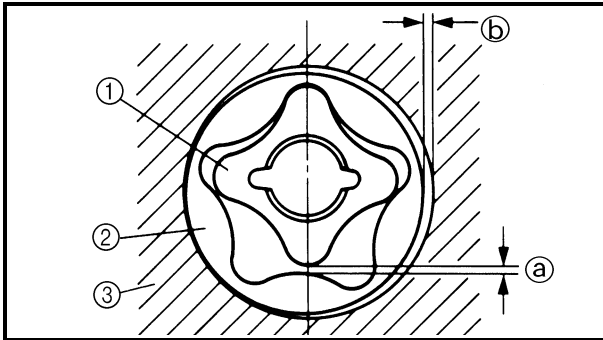

#### 2. Measure:

- Tip clearance (a)  
(between the inner rotor ① and the outer rotor ②)
  - Side clearance (b)  
(between the outer rotor ② and the pump housing ③)
- Out of specification → Replace the oil pump.



**Tip clearance (a):**

**0.12 mm (0.005 in)**

**<Limit>: 0.2 mm (0.008 in)**

**Side clearance (b):**

**0.03 ~ 0.08 mm (0.001 ~ 0.003 in)**

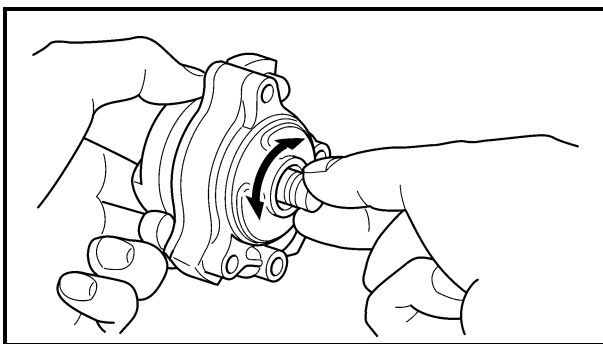

#### 3. Check:

- Oil pump operation
- Unsmooth → Repeat steps (1) and (2) or replace the defective parts.

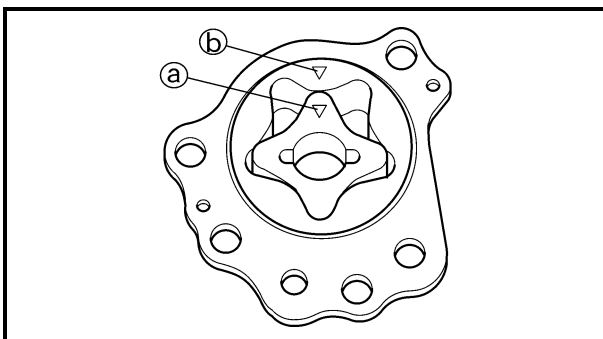

### ASSEMBLING THE OIL PUMP

#### 1. Install:

- Oil pump inner rotor 2
- Oil pump outer rotor 2

#### NOTE:

Align the match mark (a) on the inner rotor 2 with the match mark (b) on the outer rotor 2.



SHIFT SHAFT

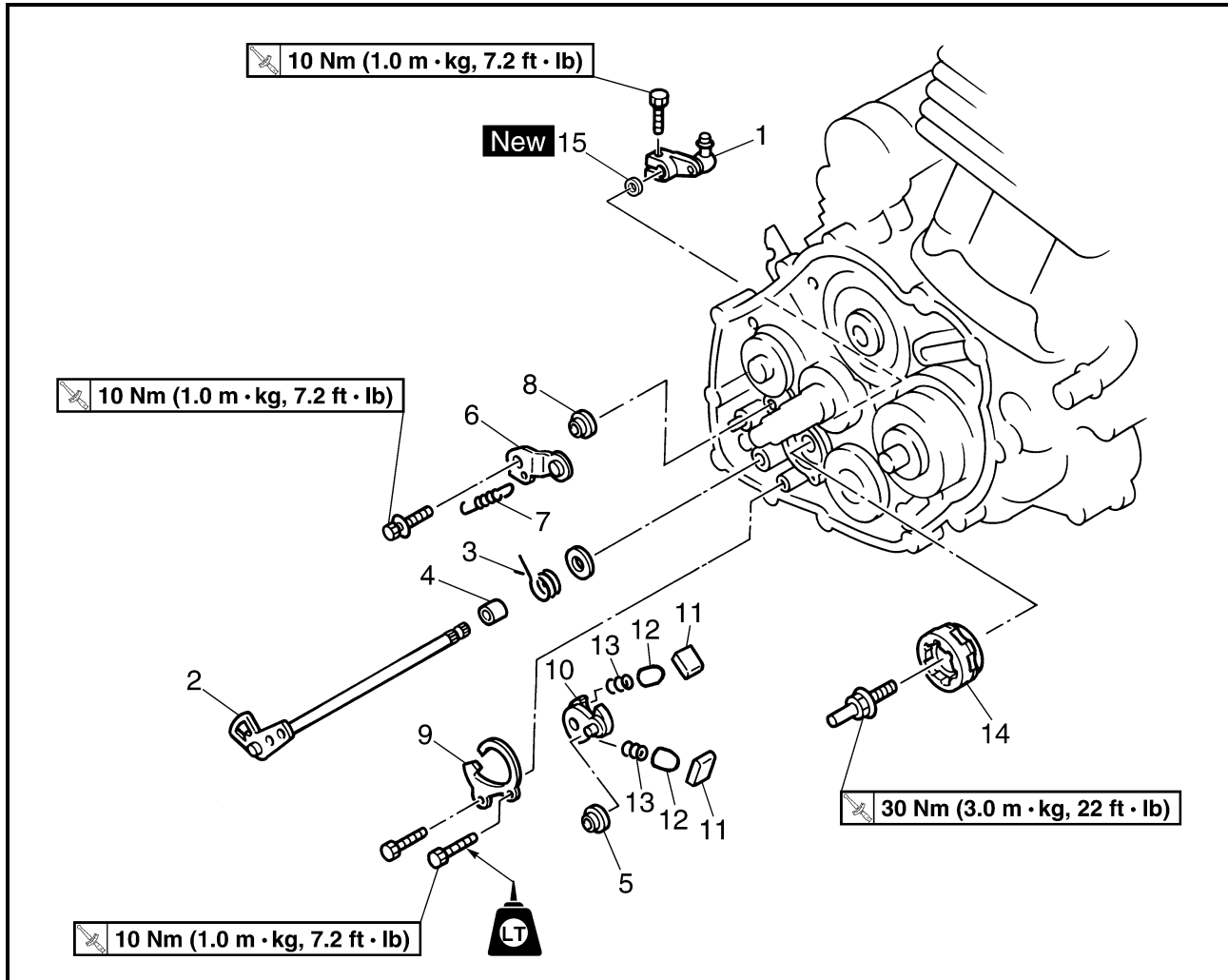

Order	Job name/Part name	Q'ty	Remarks
	<b>Removing the shift shaft</b>		
	Clutch		Remove the parts in the order below. Refer to "CLUTCH".
1	Shift arm	1	Refer to "INSTALLING THE SHIFT SHAFT".
2	Shift shaft	1	
3	Shift shaft spring	1	
4	Collar	1	
5	Roller	1	Refer to "INSTALLING THE STOPPER LEVER".
6	Stopper lever	1	
7	Stopper lever spring	1	
8	Roller	1	

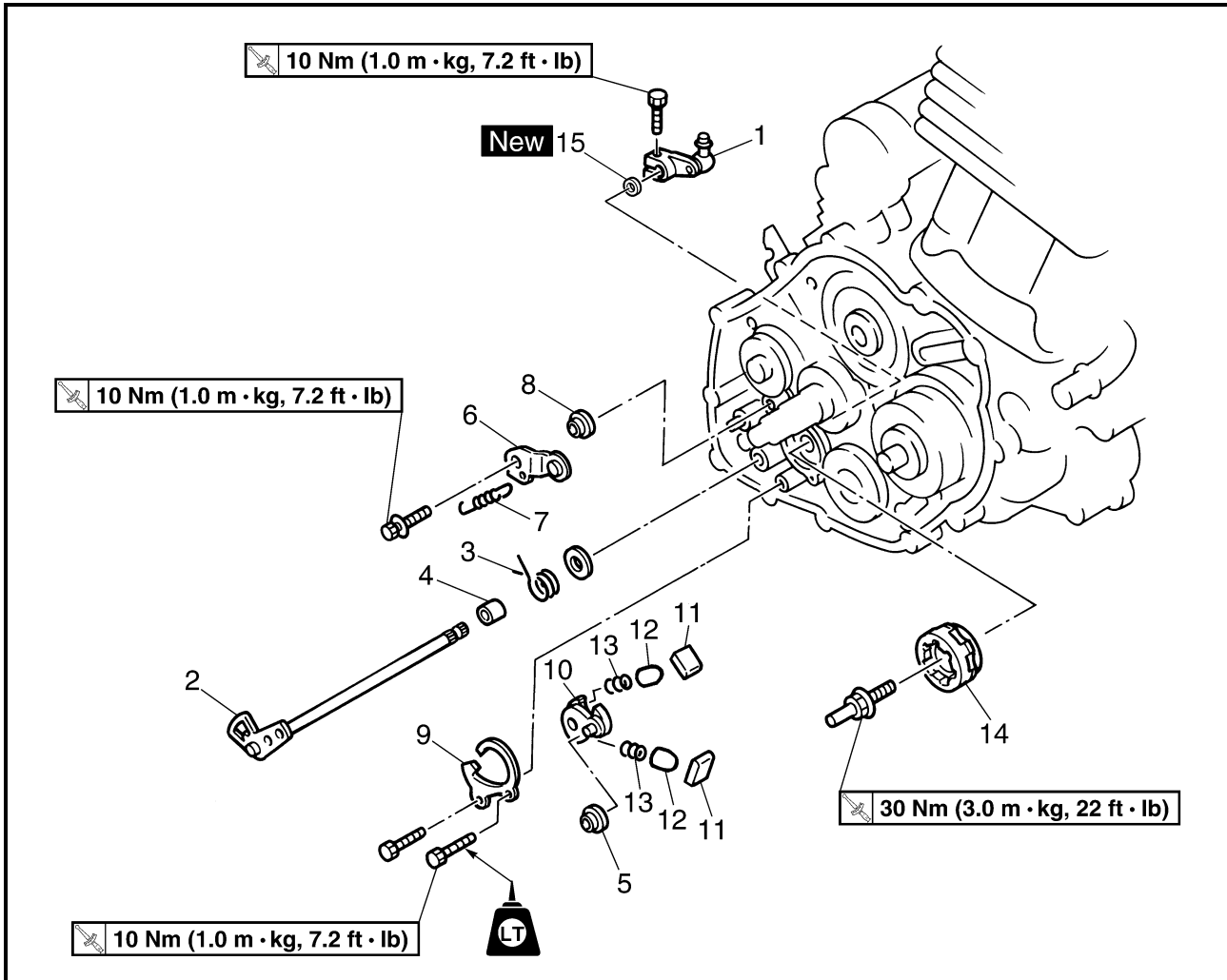

Order	Job name/Part name	Q'ty	Remarks
9	Shift guide	1	Refer to "INSTALLING THE SHIFT LEVER".
10	Shift lever	1	
11	Pawl	2	
12	Pawl pin	2	
13	Spring	2	
14	Segment	1	
15	Oil seal	1	
			For installation, reverse the removal procedure.

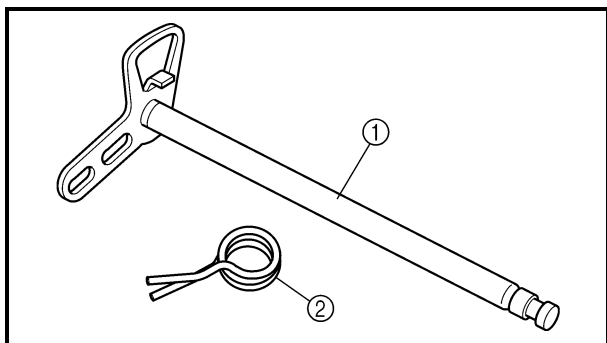

## CHECKING THE SHIFT SHAFT

1. Check:

- Shift shaft ①  
Bends/damage/wear → Replace.
- Shift shaft spring ②  
Damage/wear → Replace.

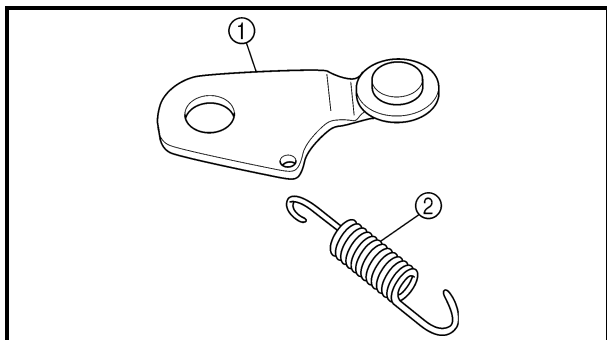

## CHECKING THE STOPPER LEVER

1. Check:

- Stopper lever ①  
Bends/damage → Replace.  
Roller turns roughly → Replace the stopper lever.
- Stopper spring ②  
Damage → Replace.

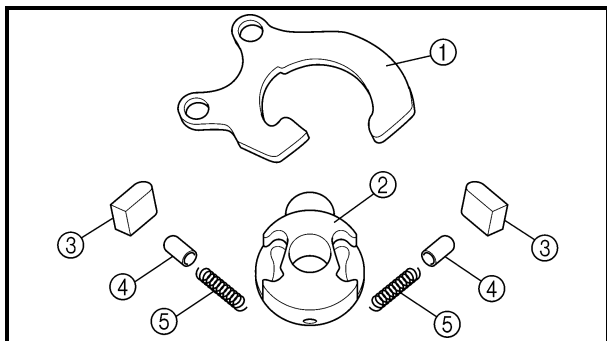

## CHECKING THE SHIFT GUIDE AND SHIFT LEVER

1. Check:

- Shift guide ①
- Shift lever ②
- Pawl ③
- Pawl pin ④
- Spring ⑤  
Damage/wear → Replace.

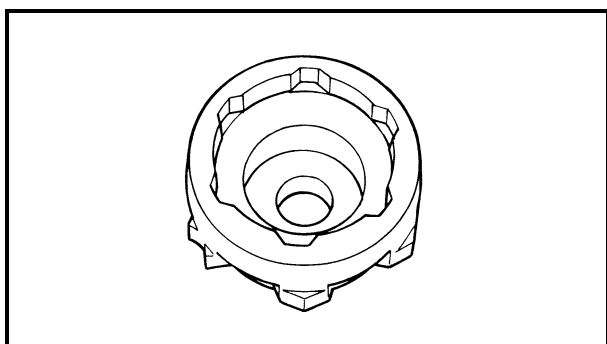

## CHECKING THE SEGMENT

1. Check:

- Segment  
Damage/wear → Replace.

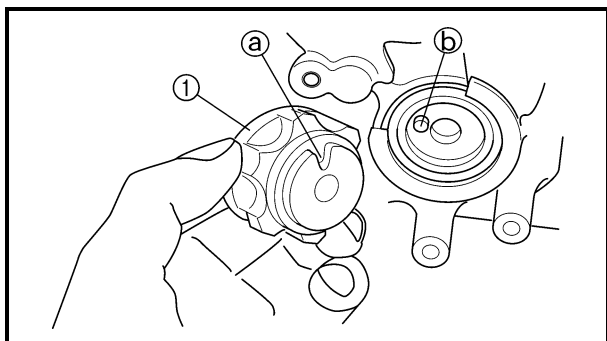

## INSTALLING THE SHIFT LEVER

1. Install:

- Segment ①
- Segment bolt  **30 Nm (3.0 m • kg, 22 ft • lb)**

### NOTE:

Align the notch ① on the segment with the pin ② on the shift cam.

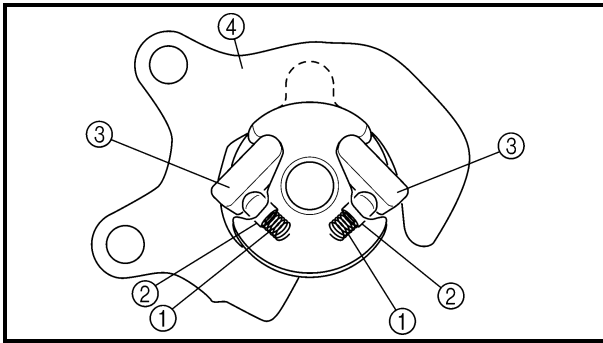

- 2.Install:
- Springs ①
  - Pawl pins ②
  - Pawls ③
  - Shift guide ④  
(to the shift lever)

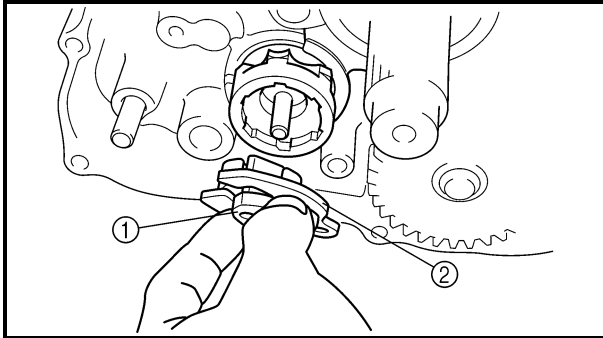

- 3.Install:
- Shift lever assembly ①
  - Shift guide ②

**NOTE:** \_\_\_\_\_  
 The shift lever assembly is installed at the same time as the shift guide.  
 \_\_\_\_\_

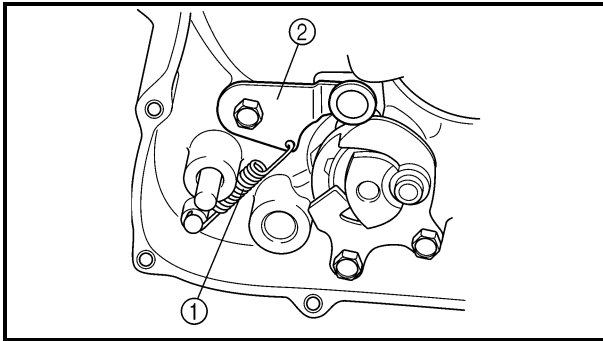

### INSTALLING THE STOPPER LEVER

- 1.Install:
- Roller
  - Stopper lever spring ①
  - Stopper lever ②

**NOTE:** \_\_\_\_\_  
 ● Hook the ends of the stopper lever spring onto the stopper lever and the crankcase boss.  
 ● Mesh the stopper lever with the shift drum segment.  
 \_\_\_\_\_



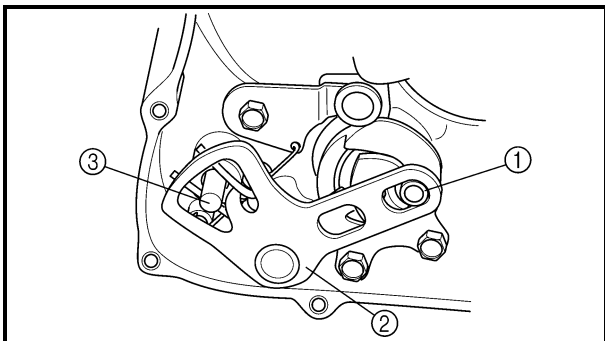

## INSTALLING THE SHIFT SHAFT

1. Install:

- Roller ①
- Collar
- Shift shaft spring
- Shift shaft ②

**NOTE:** \_\_\_\_\_

- Install the end of the shift shaft spring onto the shift shaft spring stopper ③.
- Install the end of the shift shaft lever onto the roller ①.

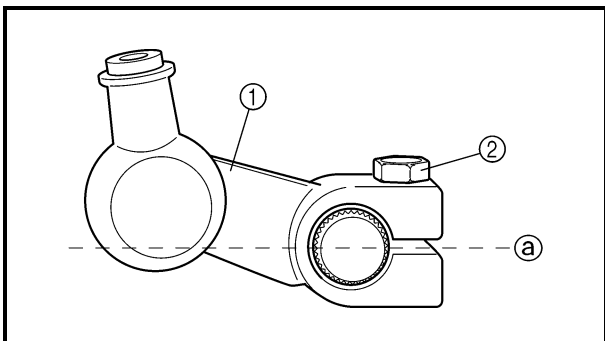

2. Install:

- Shift arm ①
- Bolt ②

**10 Nm (1.0 m • kg, 7.2 ft • lb)**

**NOTE:** \_\_\_\_\_

Be sure to install the shaft arm so that position ② is horizontal.



# CRANKCASE

## TIMING CHAIN AND SPEED SENSOR ROTOR

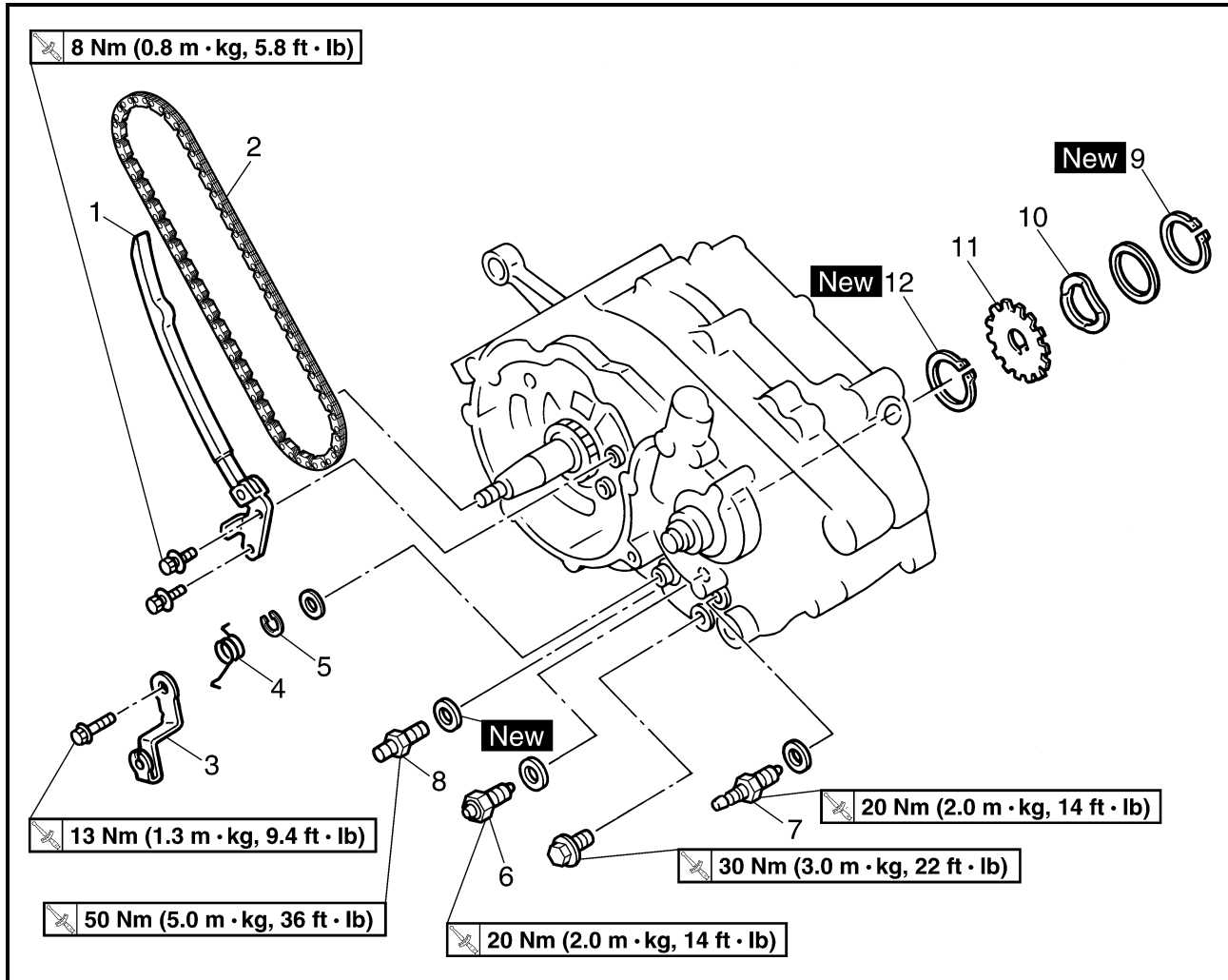

Order	Job name/Part name	Q'ty	Remarks
	<b>Removing the timing chain and speed sensor rotor</b>		Remove the parts in the order below.
	Engine assembly		Refer to "ENGINE REMOVAL".
	Cylinder head cover		Refer to "CYLINDER HEAD COVER".
	Cylinder head		Refer to "CAMSHAFT AND CYLINDER HEAD".
	Cylinder and piston		Refer to "CYLINDER AND PISTON".
	AC rotor		Refer to "AC MAGNETO".
	Clutch, balancer drive gear and balancer driven gear		Refer to "CLUTCH".
	Oil pump		Refer to "OIL PUMP".
	Shift shaft and shift drum segment		Refer to "SHIFT SHAFT".
1	Timing chain guide (intake)	1	
2	Timing chain	1	

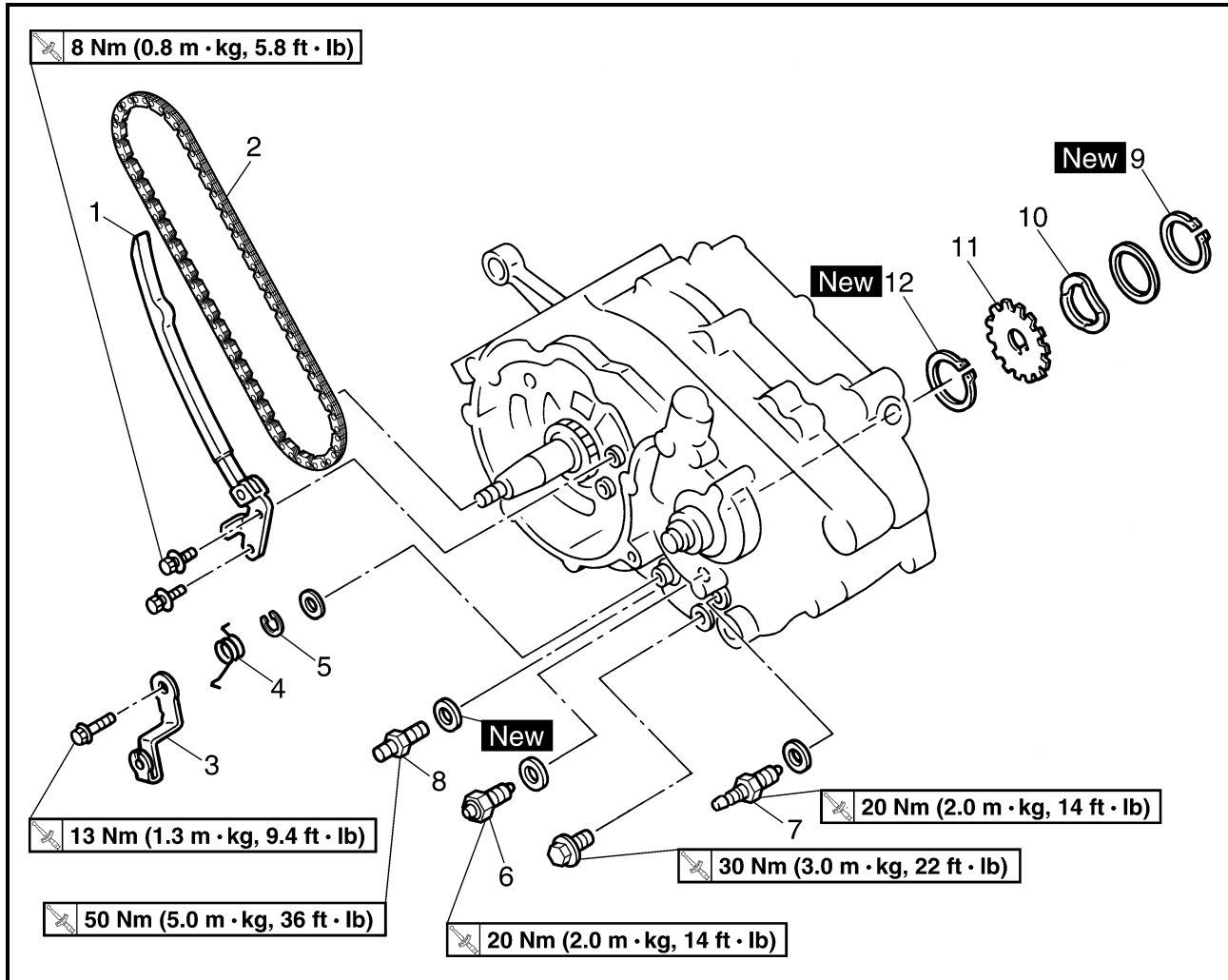

Order	Job name/Part name	Q'ty	Remarks
3	Reverse shift lever	1	
4	Reverse shift lever spring	1	
5	Circlip	1	
6	Neutral switch	1	
7	Reverse switch	1	
8	Oil pipe joint	1	
9	Circlip	1	
10	Wave washer	1	
11	Speed sensor rotor	1	
12	Circlip	1	
			For installation, reverse the removal procedure.



CRANKCASE

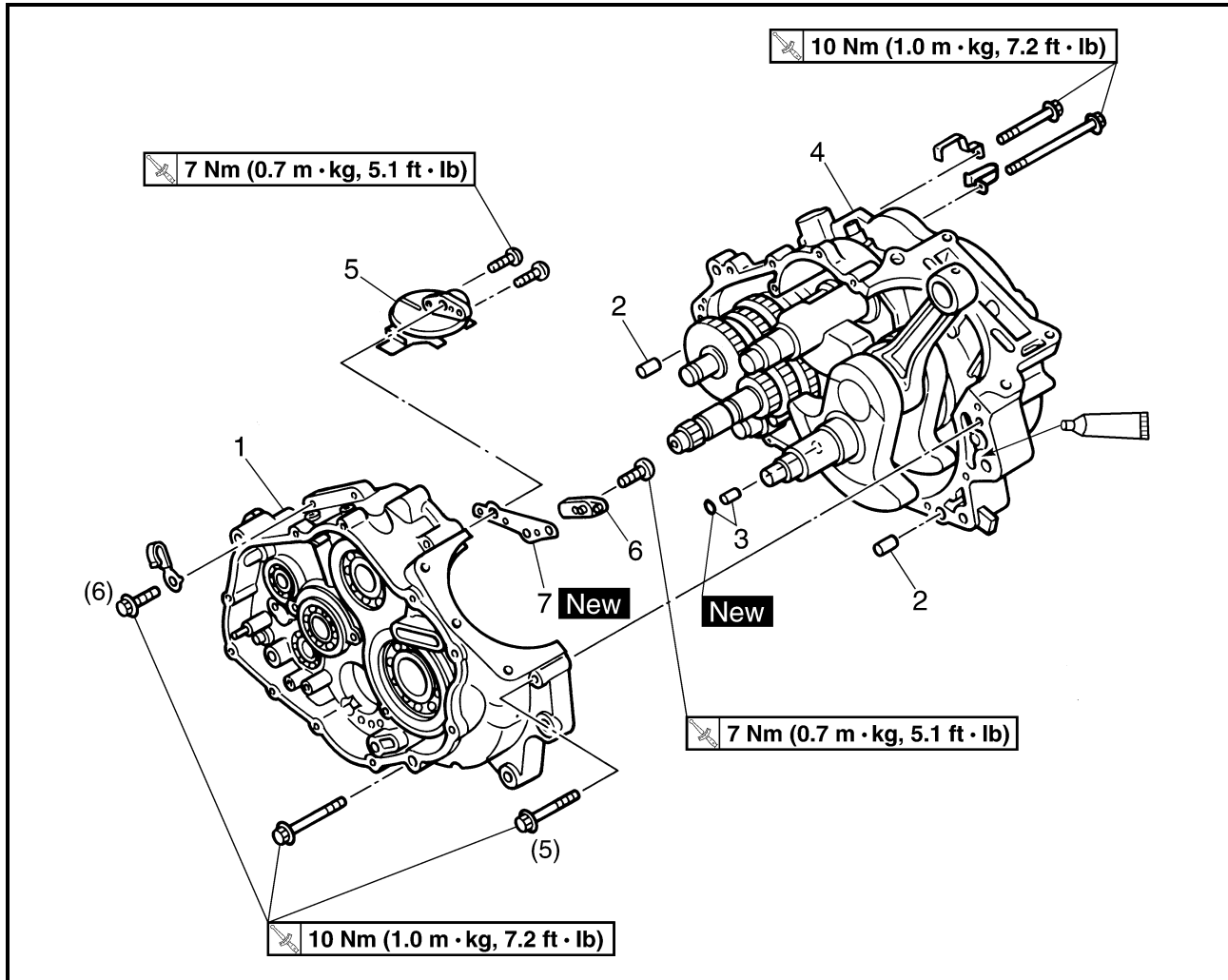

Order	Job name/Part name	Q'ty	Remarks
	<b>Separating the crankcase</b>		Remove the parts in the order below.
1	Right crankcase	1	Refer to "CRANKCASE".
2	Dowel pin	2	
3	Dowel pin/O-ring	1/1	
4	Left crankcase	1	
5	Oil strainer	1	
6	Cover	1	
7	Oil strainer gasket	1	
			For installation, reverse the removal procedure.



CRANKCASE BEARING

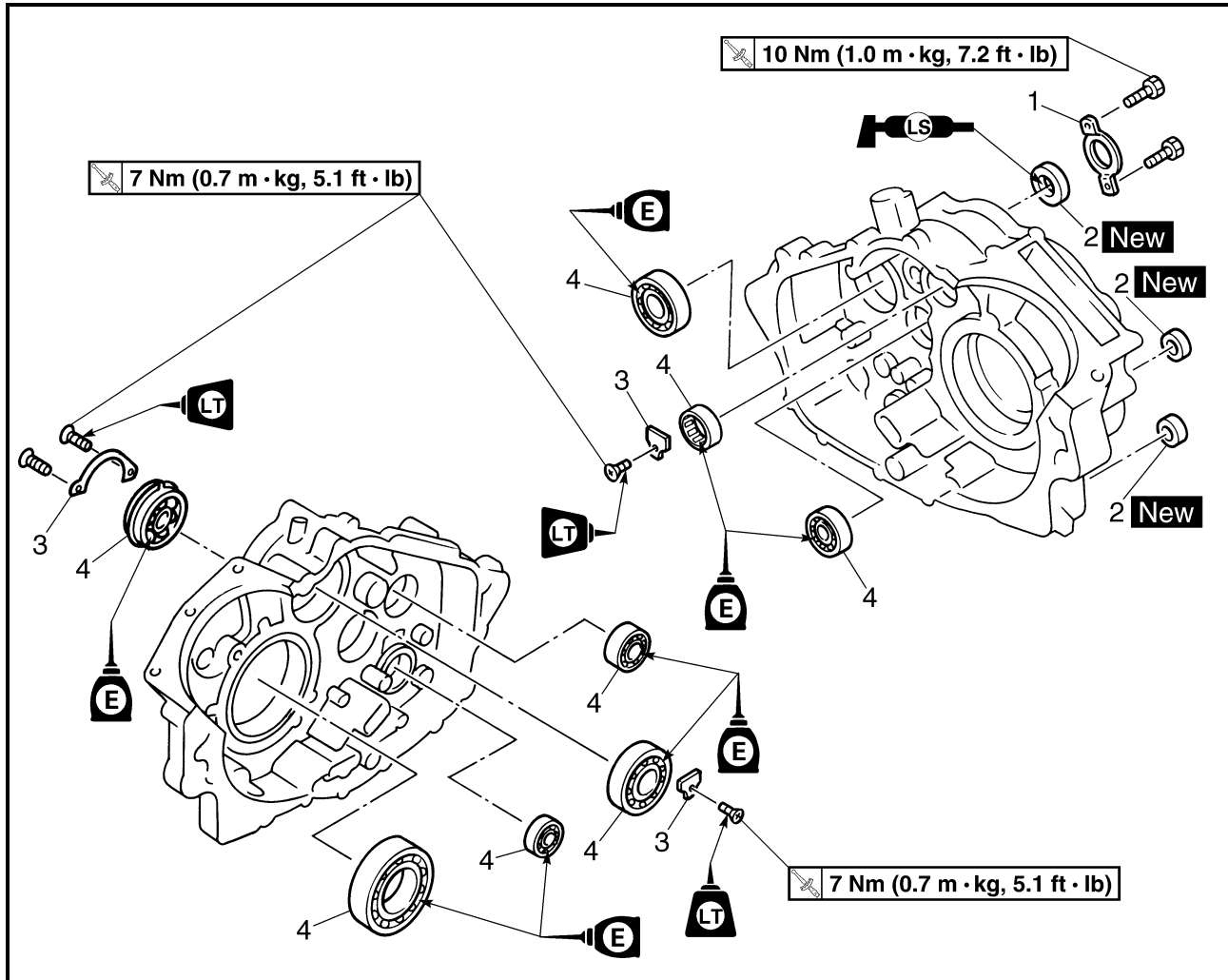

Order	Job name/Part name	Q'ty	Remarks
	<b>Removing the crankcase bearing</b>		Remove the parts in the order below.
	Crankshaft and balancer		Refer to "CRANKSHAFT AND BALANCER".
	Transmission		Refer to "TRANSMISSION".
1	Oil seal retainer	1	
2	Oil seal	3	
3	Bearing retainer	3	
4	Bearing	8	
			For installation, reverse the removal procedure.

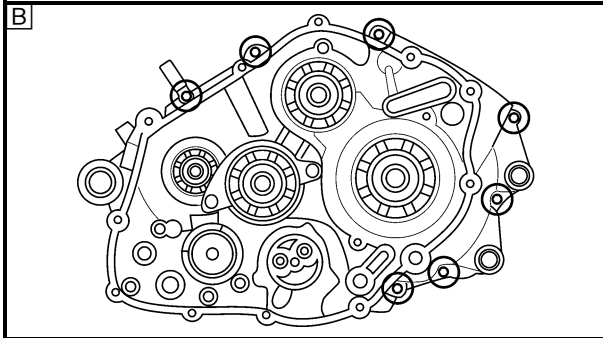
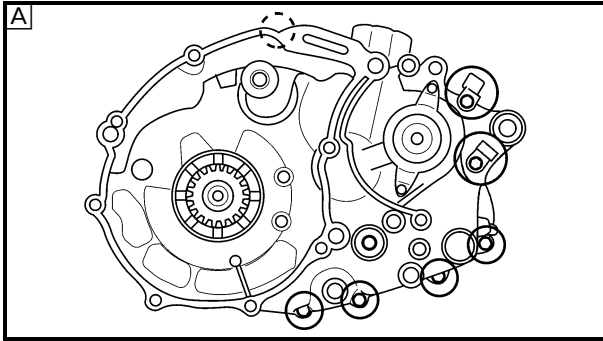

**SEPARATING THE CRANKCASE**

1. Separate:

- Left crankcase
- Right crankcase

\*\*\*\*\*

**Separation steps:**

- Remove the crankcase bolts.

**NOTE:**

- Loosen each bolt 1/4 of a turn at a time and after all the bolts are loosened, remove them.
- Loosen the bolts in stages, using a criss-cross pattern.

**A** Left crankcase

**B** Right crankcase

- Remove the right crankcase.

**CAUTION:**

Use a soft hammer to tap on one side of the crankcase. Tap only on reinforced portions of the crankcase. Do not tap on the crankcase mating surfaces. Work slowly and carefully. Make sure that the crankcase halves separate evenly.

- Remove the dowel pins and O-ring.

\*\*\*\*\*

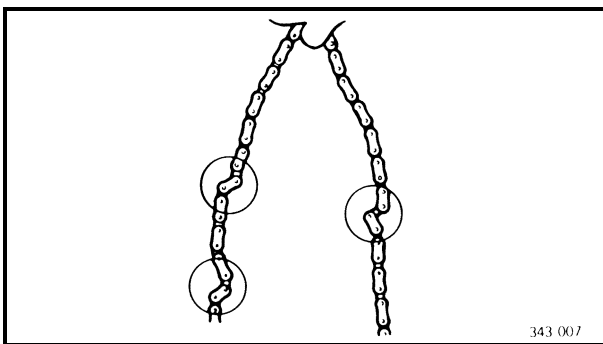

**CHECKING THE TIMING CHAIN AND GUIDE**

1. Check:

- Timing chain  
Cracks/stiff → Replace the timing chain and camshaft sprocket as a set.

2. Check:

- Intake side timing chain guide  
Wear/damage → Replace.

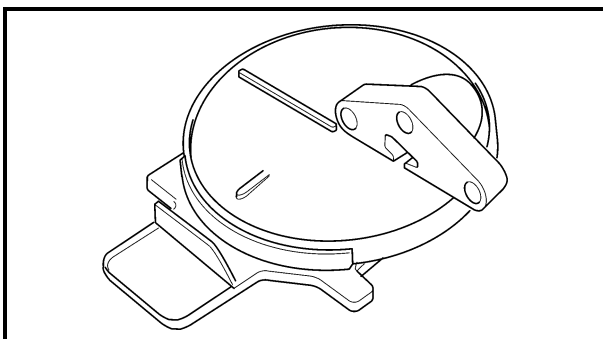

**CHECKING THE OIL STRAINER**

1. Check:

- Oil strainer  
Damage → Replace.  
Contaminations → Clean with engine oil.



### CHECKING THE CRANKCASE

1. Thoroughly wash the case halves in a mild solvent.
2. Clean all the gasket mating surfaces and crankcase mating surfaces thoroughly.
3. Check:
  - Crankcase  
Cracks/damage → Replace.
  - Oil delivery passages  
Clogged → Blow out with compressed air.

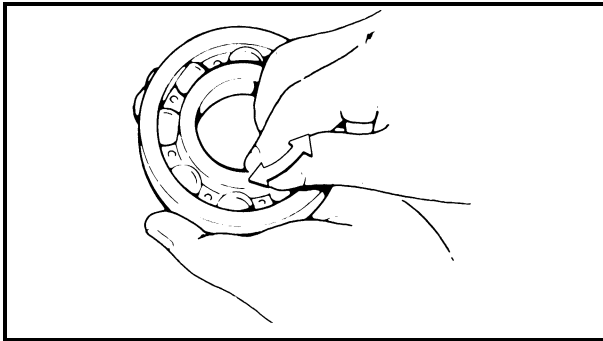

### CHECKING THE BEARINGS

1. Check:
  - Bearing  
Clean and lubricate, then rotate the inner race with a finger.  
Roughness → Replace.

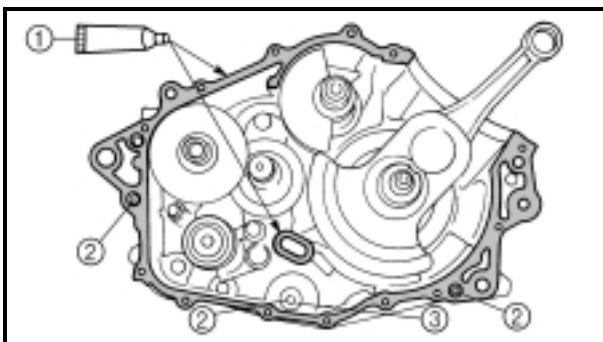

### ASSEMBLING THE CRANKCASE

1. Apply:
  - Sealant (Quick Gasket®) ①  
(to the mating surfaces of both case halves)



**Sealant (Quick Gasket®):**  
**P/N. ACC-11001-05-01**  
**Yamaha bond No. 1215:**  
**P/N. 90890-85505**

2. Install:
  - Dowel pin ②
  - O-ring ③ **New**



3. Fit the right crankcase onto the left crankcase. Tap lightly on the case with a soft hammer.

**CAUTION:**

Before installing and torquing the crankcase holding bolts, be sure to check whether the transmission is functioning properly by manually rotating the shift cam in both directions.

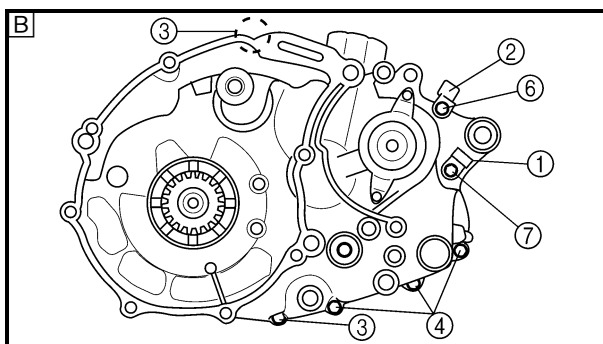
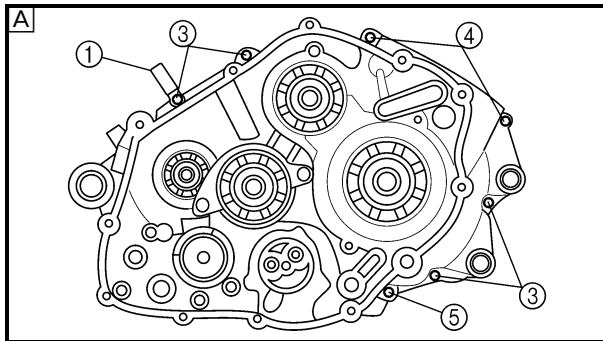

4. Install:

- Lead guides ①
- Hose guide ②
- Crankcase bolts

5. Tighten:

- Crankcase bolts  
(follow the proper tightening sequence)

10 Nm (1.0 m • kg, 7.2 ft • lb)

**A** Right crankcase

**B** Left crankcase

③ Bolt:  $l = 30$  mm

④ Bolt:  $l = 45$  mm

⑤ Bolt:  $l = 60$  mm

⑥ Bolt:  $l = 65$  mm

⑦ Bolt:  $l = 80$  mm

**NOTE:**

Tighten the bolts in stages, using a crisscross pattern.

6. Apply:

- 4-stroke engine oil  
(to the crank pin, bearing and oil delivery hole)

7. Check:

- Crankshaft and transmission operation  
Unsmooth operation → Repair.



CRANKSHAFT AND BALANCER

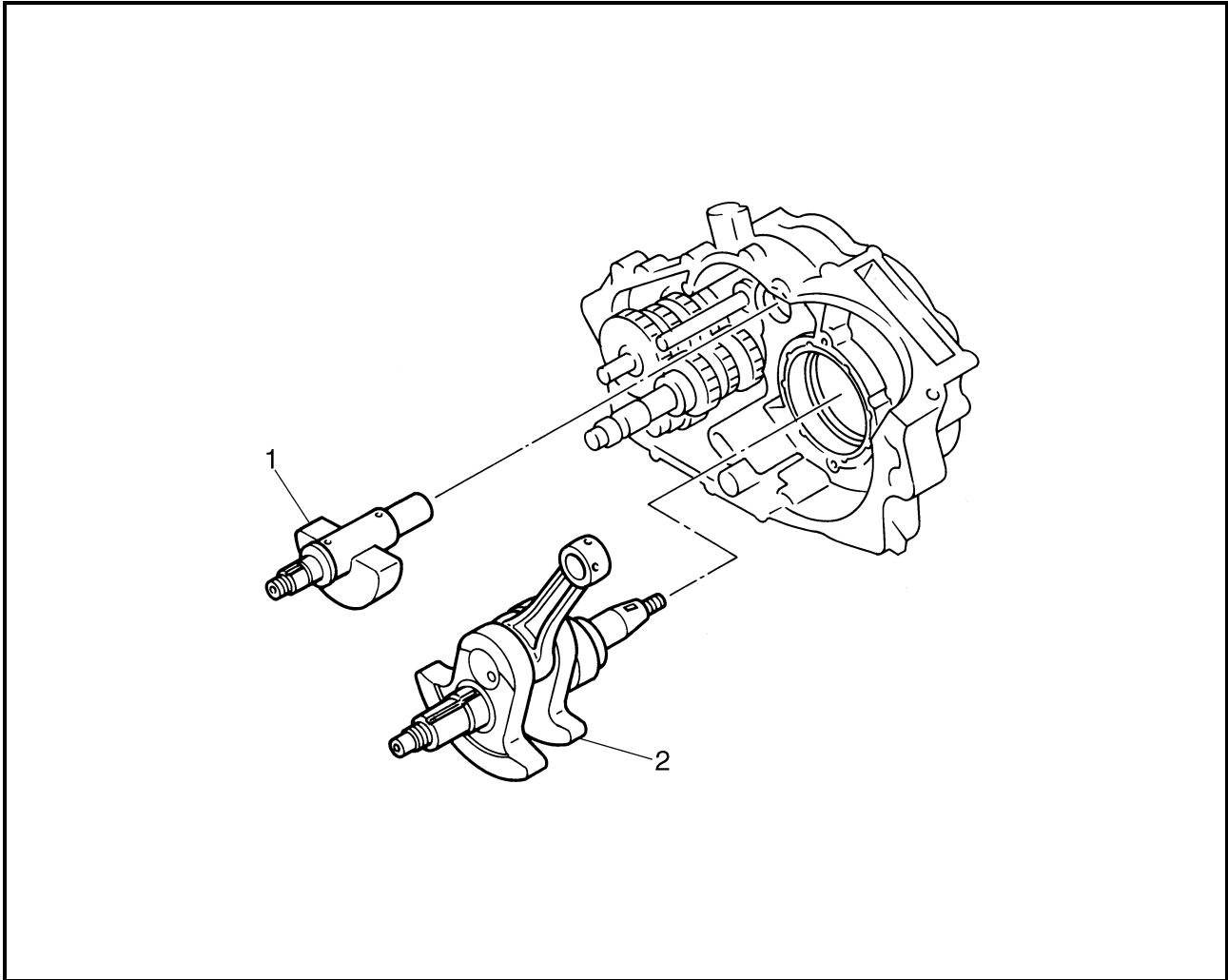

Order	Job name/Part name	Q'ty	Remarks
	<b>Removing the crankshaft and balancer</b>		Remove the parts in the order below.
	Crankcase		Separate. Refer to "CRANKCASE".
1	Balancer	1	
2	Crankshaft	1	Refer to "REMOVING/INSTALLING THE CRANKSHAFT". For installation, reverse the removal procedure.

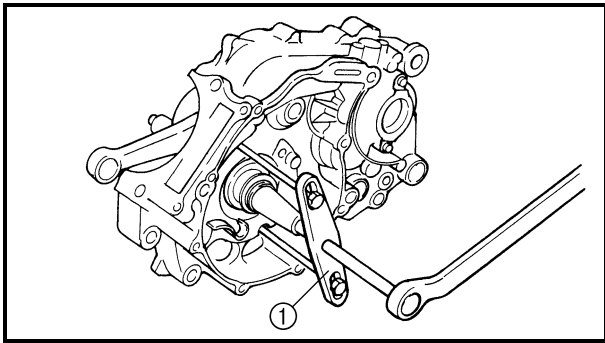

## REMOVING THE CRANKSHAFT

1.Remove:

- Crankshaft  
Use a crankcase separating tool ①.



**Crankcase separating tool:**  
P/N. YU-01135-A, 90890-01135

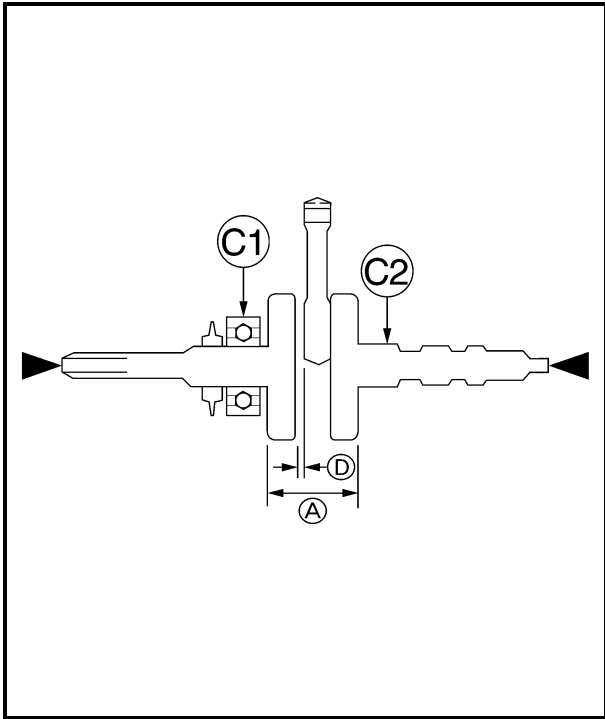

## CHECKING THE CRANKSHAFT

1.Measure:

- Crank width (A)  
Out of specification → Replace the crankshaft.



**Crank width:**  
74.95 ~ 75.00 mm  
(2.9508 ~ 2.9528 in)

- Side clearance (D)  
Out of specification → Replace the crankshaft.



**Big end side clearance:**  
0.32 ~ 0.64 mm  
(0.0126 ~ 0.0252 in)  
<Limit>: 1.0 mm (0.040 in)

- Runout (C)  
Out of specification → Replace the crankshaft.



**Runout limit:**  
C1: 0.03 mm (0.0012 in)  
C2: 0.03 mm (0.0012 in)

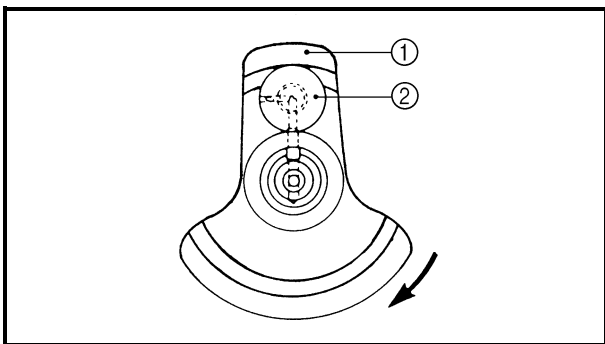

## Crankshaft reassembling point:

The crankshaft ① and the crank pin ② oil passages must be properly interconnected with a tolerance of less than 1 mm (0.04 in).

## CAUTION:

The buffer boss and woodruff key should be replaced when removed from the crankshaft.

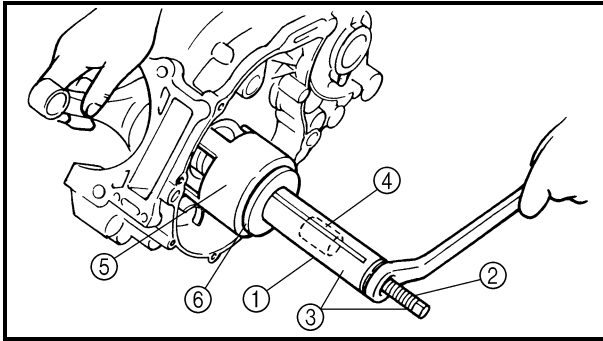

### INSTALLING THE CRANKSHAFT

1. Install:

- Crankshaft



**Crankshaft installer pot ①:**

**P/N. 90890-01274**

**Crankshaft installer bolt ②:**

**P/N. 90890-01275**

**Crankshaft installer set ③:**

**P/N. YU-90050**

**Adapter ④:**

**P/N. YM-90069, 90890-04059**

**Spacer (crankshaft installer) ⑤:**

**P/N. YM-91044, 90890-04081**

**Spacer ⑥:**

**P/N. 90890-01016**

### NOTE:

Hold the connecting rod at the Top Dead Center (TDC) with one hand while turning the nut of the installing tool with the other. Operate the installing tool until the crankshaft bottoms against the bearing.

### CAUTION:

Apply engine oil to each bearing to protect the crankshaft against scratches and to make installation easier.



TRANSMISSION

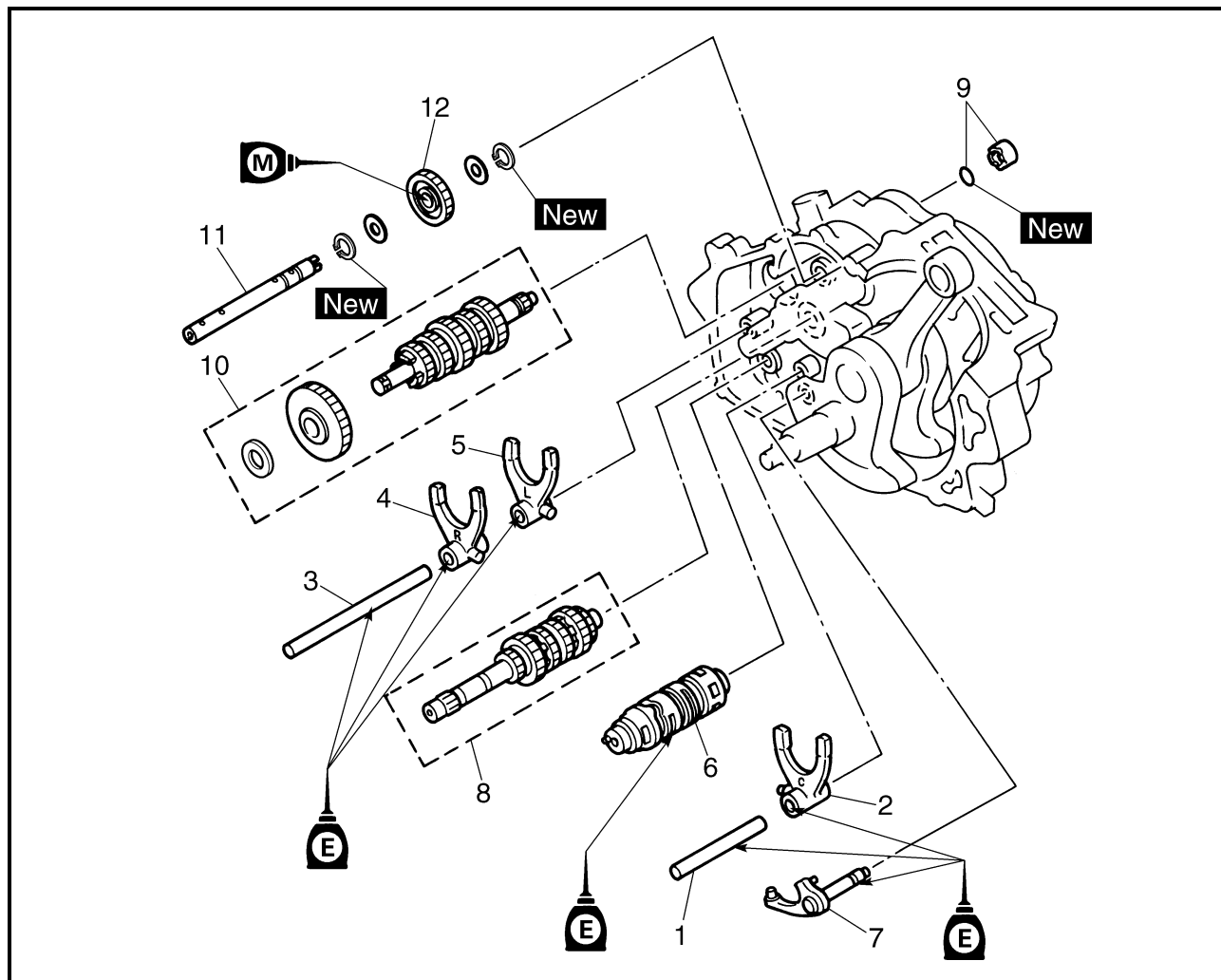

Order	Job name/Part name	Q'ty	Remarks
	<b>Removing the transmission</b>		
	Crankcase		Remove the parts in the order below. Separate. Refer to "CRANKCASE".
1	Shift fork guide bar (short)	1	Refer to "INSTALLING THE TRANSMISSION".
2	Shift fork "C"	1	
3	Shift fork guide bar (long)	1	
4	Shift fork "R"	1	
5	Shift fork "L"	1	
6	Shift drum	1	
7	Reverse shift shaft	1	
8	Main axle assembly	1	
9	Spacer/O-ring	1/1	
10	Drive axle	1	

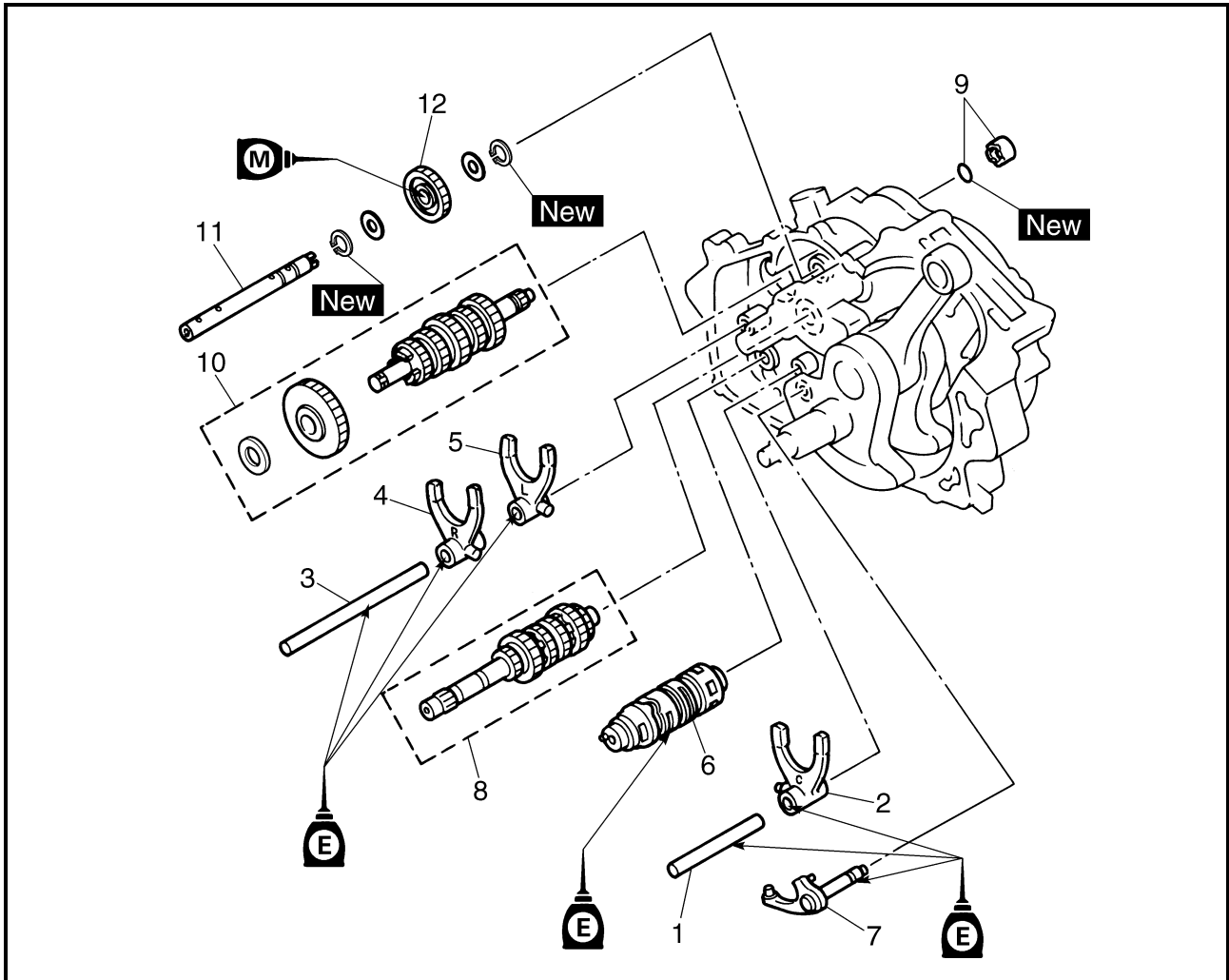

Order	Job name/Part name	Q'ty	Remarks
11	Counter axle	1	For installation, reverse the removal procedure.
12	Counter gear	1	



MAIN AXLE

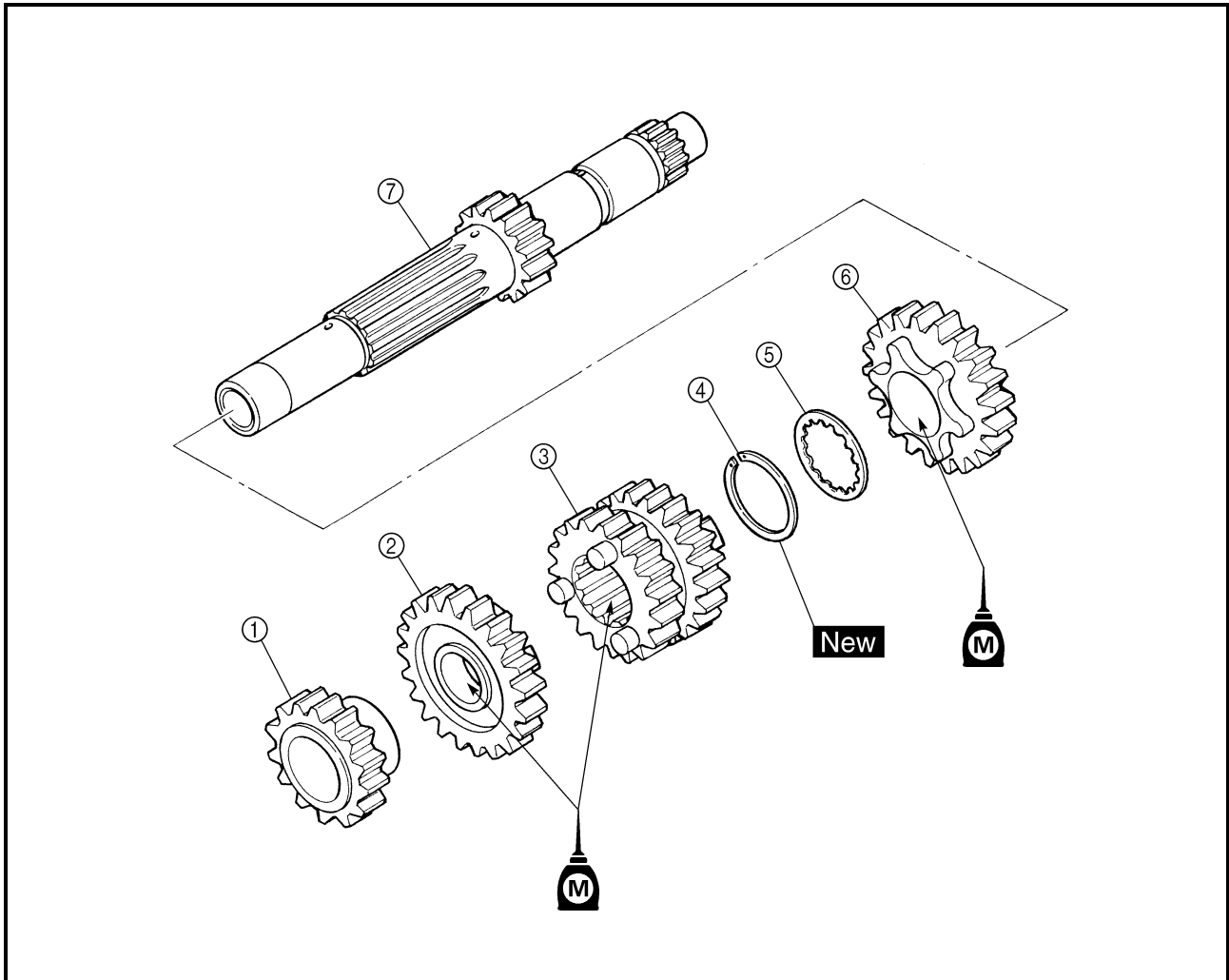

Order	Job name/Part name	Q'ty	Remarks
	<b>Disassembling the main axle</b>		Remove the parts in the order below.
①	Reverse pinion gear	1	
②	4th pinion gear	1	
③	2nd/3rd pinion gear	1	
④	Circlip	1	Refer to "ASSEMBLING THE MAIN AXLE AND DRIVE AXLE".
⑤	Toothed washer	1	
⑥	5th pinion gear	1	
⑦	Main axle/1st pinion gear	1	
			For assembly, reverse the disassembly procedure.



DRIVE AXLE

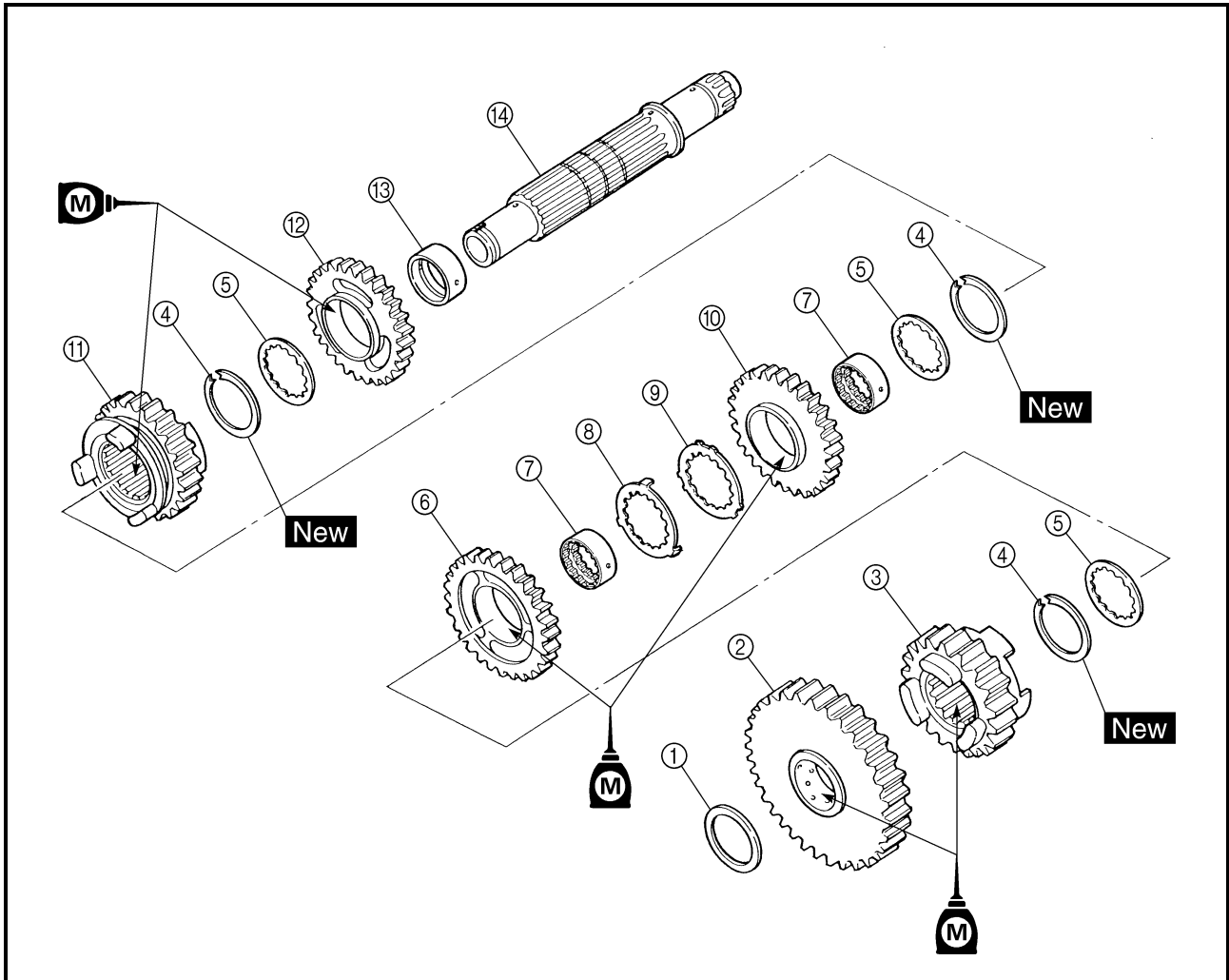

Order	Job name/Part name	Q'ty	Remarks
	<b>Disassembling the drive axle</b>		Remove the parts in the order below.
①	Washer	1	
②	1st wheel gear	1	
③	5th wheel gear	1	
④	Circlip	3	Refer to "ASSEMBLING THE MAIN AXLE AND DRIVE AXLE".
⑤	Toothed washer	3	
⑥	3rd wheel gear	1	
⑦	Toothed collar	2	
⑧	Toothed lock washer	1	
⑨	Toothed lock washer retainer	1	
⑩	2nd wheel gear	1	

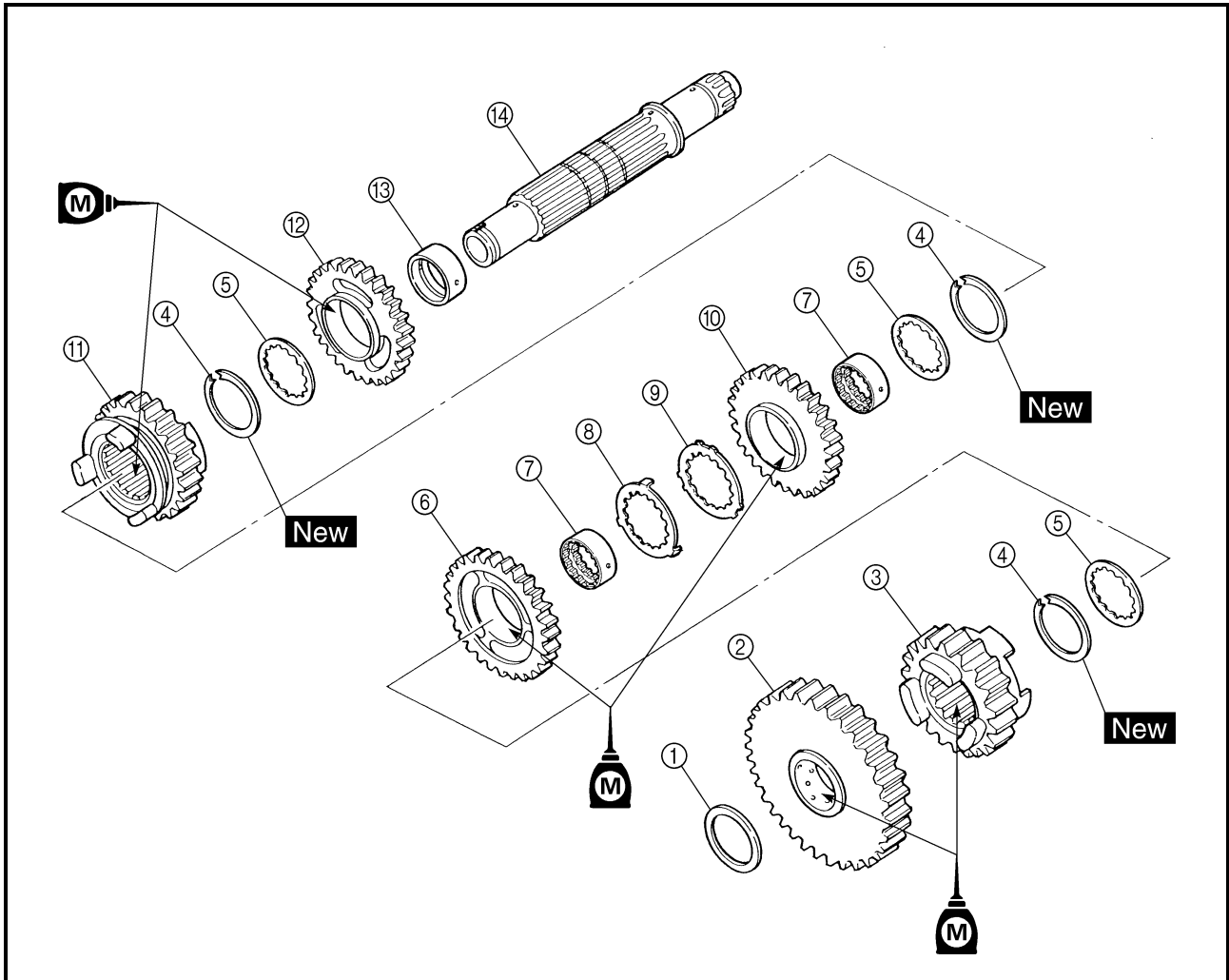

Order	Job name/Part name	Q'ty	Remarks
⑪	4th wheel gear	1	For assembly, reverse the disassembly procedure.
⑫	Reverse wheel gear	1	
⑬	Collar	1	
⑭	Drive axle	1	

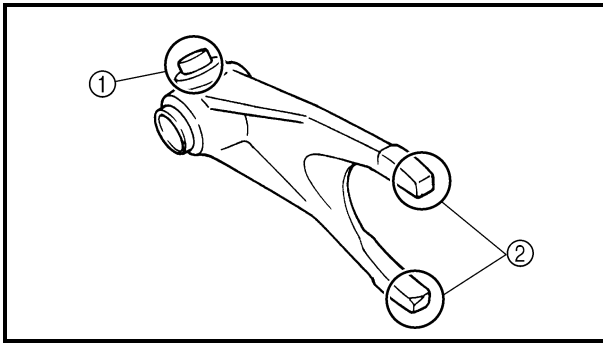

**CHECKING THE SHIFT FORK**

1.Check:

- Shift fork cam follower ①
  - Shift fork pawl ②
- Scoring/bends/wear/damage → Replace.

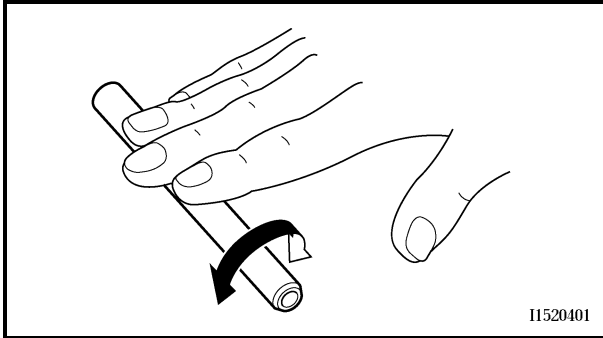

2.Check:

- Guide bar
- Roll the guide bar on a flat surface.  
Bends → Replace.

**⚠ WARNING**

**Do not attempt to straighten a bent guide bar.**

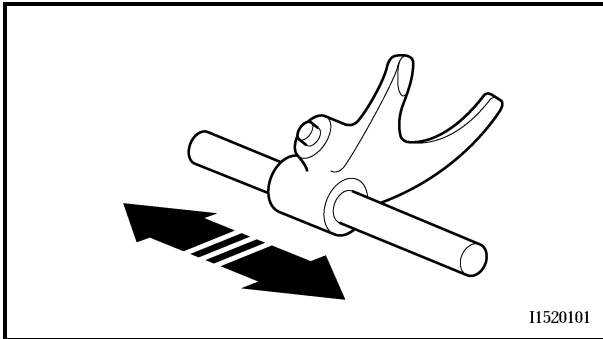

3.Check:

- Shift fork movement (on the guide bar)
- Unsmooth operation → Replace the shift fork and the guide bar as a set.

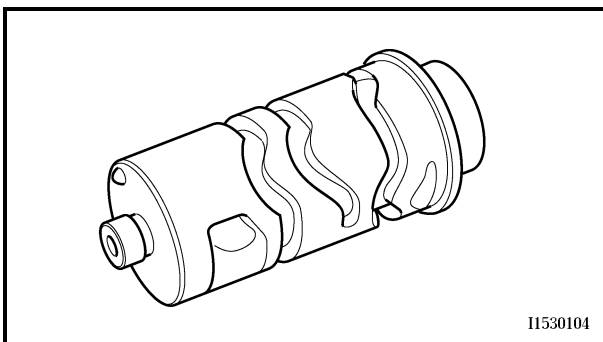
**CHECKING THE SHIFT DRUM**

1.Check:

- Shift cam grooves
- Scratches/wear/damage → Replace.

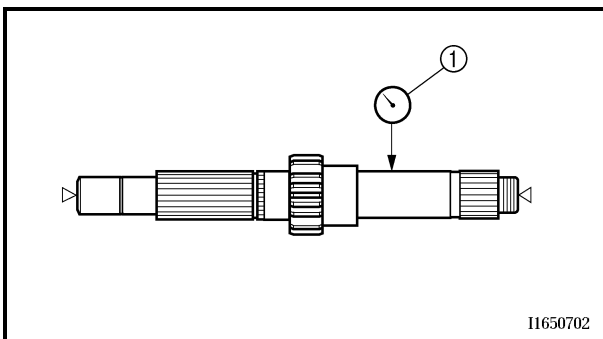
**CHECKING THE TRANSMISSION**

1.Measure:

- Main axle runout (with a centering device and dial gauge ①)
- Out of specification → Replace the main axle.



**Maximum main axle runout:  
0.08 mm (0.0031 in)**

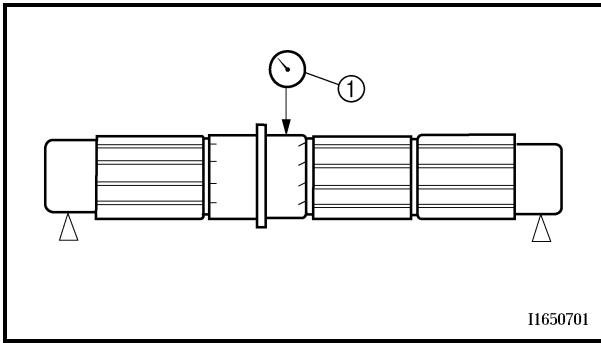

11650701

## 2.Measure:

- Drive axle runout  
(with a centering device and dial gauge ①)  
Out of specification → Replace the drive axle.



**Maximum drive axle runout:  
0.08 mm (0.0031 in)**

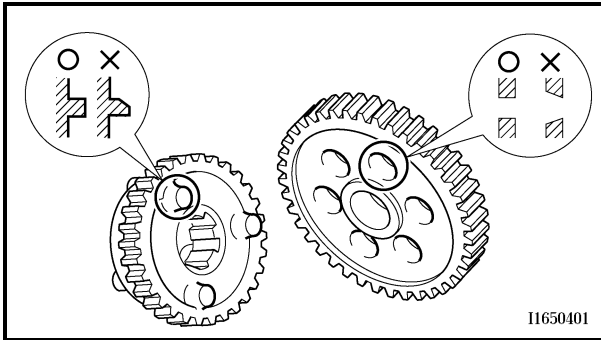

11650401

## 3.Check:

- Transmission gears  
Blue discoloration/pitting/wear → Replace the defective gear(s).
- Transmission gear dogs  
Cracks/damage/rounded edges → Replace the defective gear(s).

## 4.Check:

- Transmission gear engagement  
(each pinion gear to its respective wheel gear)  
Incorrect → Reassemble the transmission axle assemblies.

## 5.Check:

- Transmission gear movement  
Rough movement → Replace the defective part(s).

## 6.Check:

- Circlips  
Bends/damage/looseness → Replace.

## ASSEMBLING THE MAIN AXLE AND DRIVE AXLE

### 1.Install:

- Toothed washer ①
- Circlip ② **New**

### NOTE:

- Be sure the circlip shap-edged corner ③ is positioned opposite side to the toothed washer and gear.
- Be sure the circlip end ④ is positioned at axle spline groove ⑤.

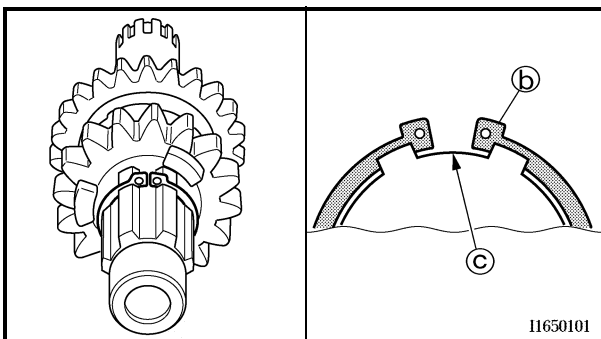
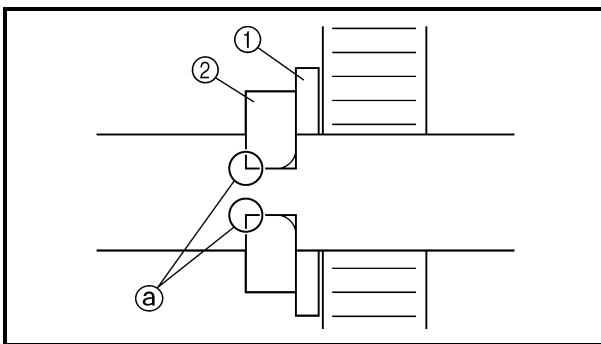

11650101

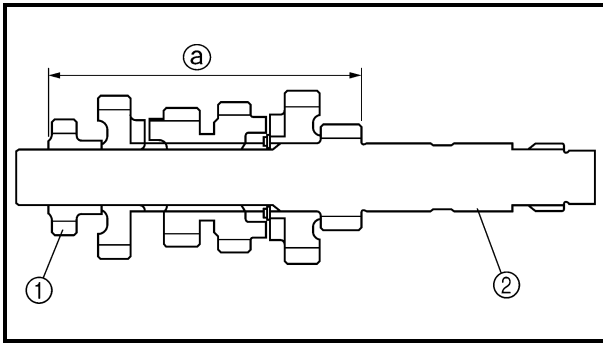

2.Install:

- Reverse pinion gear ①

**NOTE:** \_\_\_\_\_

Press the reverse pinion gear into the main axle ②, as shown in the illustration.

② 115.65 ~ 115.85 mm (4.553 ~ 4.561 in)

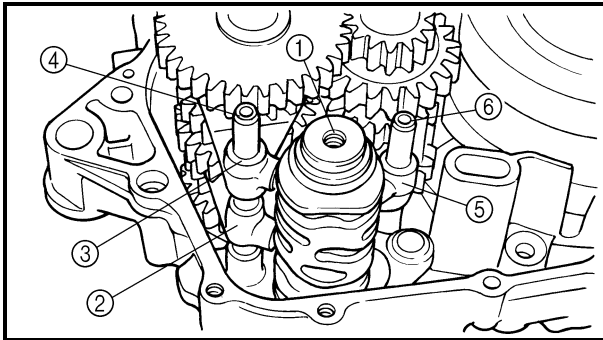

## INSTALLING THE TRANSMISSION

1.Install:

- Shift drum ①
- Shift fork "L" ②
- Shift fork "R" ③
- Shift fork guide bar (long) ④
- Shift fork "C" ⑤
- Shift fork guide bar (short) ⑥

**NOTE:** \_\_\_\_\_

The embossed marks on the shift forks should face towards the right side of the engine and be in the following sequence: "R", "C", "L".

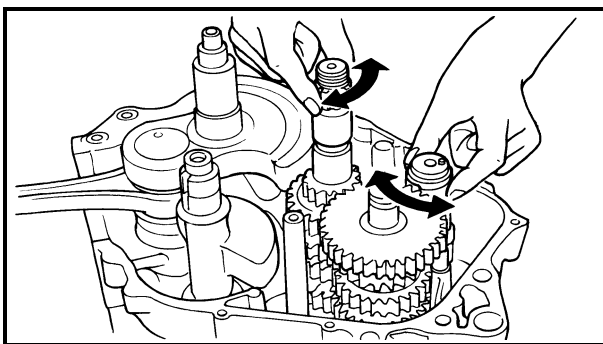

2.Check:

- Transmission  
Rough movement → Repair.

**NOTE:** \_\_\_\_\_

- Oil each gear and bearing thoroughly.
- Before assembling the crankcase, be sure that the transmission is in neutral and that the gears turn freely.

**COOLING SYSTEM**

**RADIATOR**

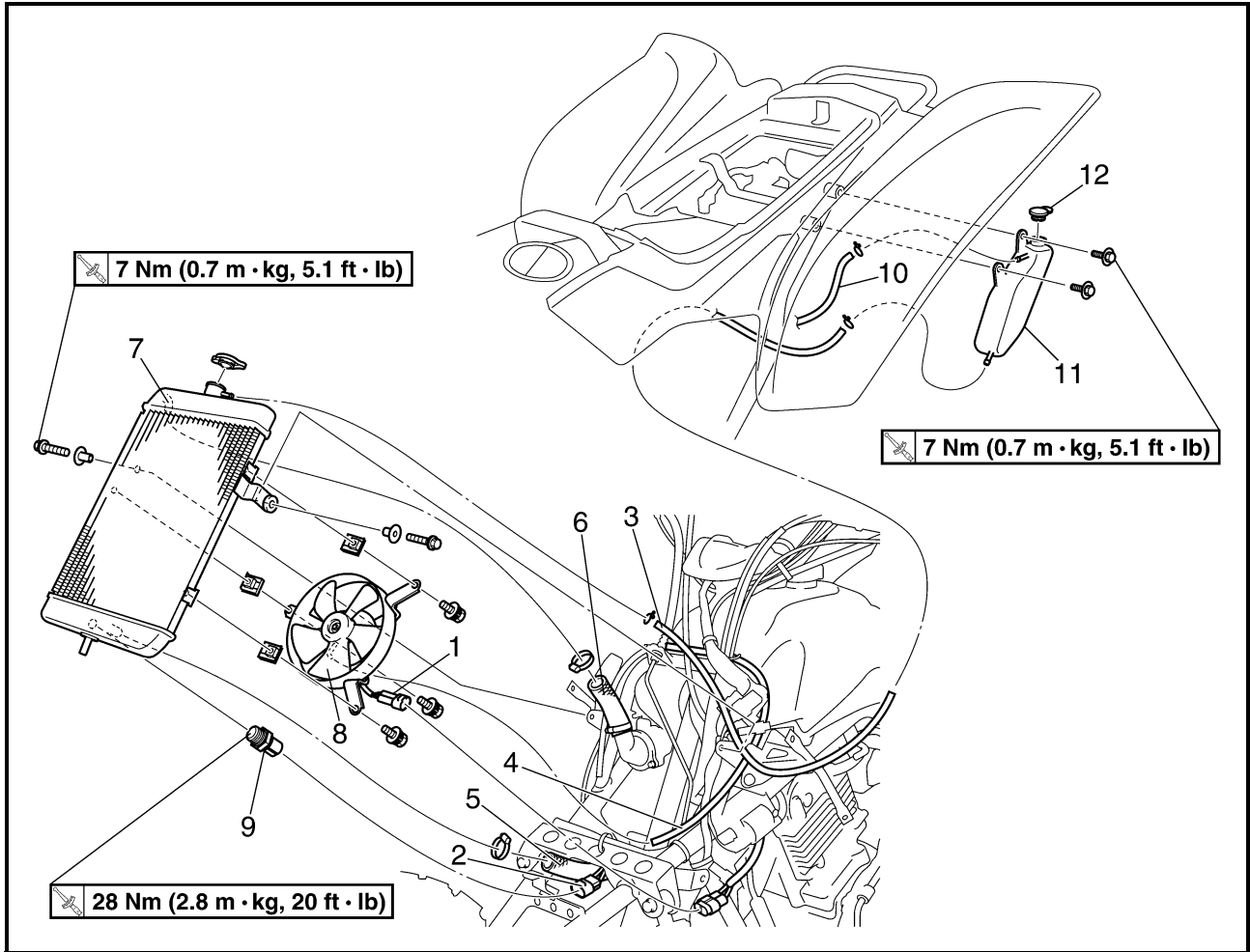

Order	Job name/Part name	Q'ty	Remarks
	<b>Removing the radiator</b>		Remove the parts in the order below.
	Front panel and front fender		Refer to "SEAT, FENDERS AND FUEL TANK" in CHAPTER 3.
	Coolant		Drain.
1	Radiator fan coupler	1	Disconnect.
2	Thermo switch coupler	1	Disconnect.
3	Coolant reservoir hose	1	
4	Radiator fan breather hose	1	Disconnect.
5	Radiator outlet hose	1	Disconnect.
6	Radiator inlet hose	1	Disconnect.
7	Radiator	1	
8	Radiator fan	1	
9	Thermo switch 1	1	
10	Coolant reservoir breather hose	1	

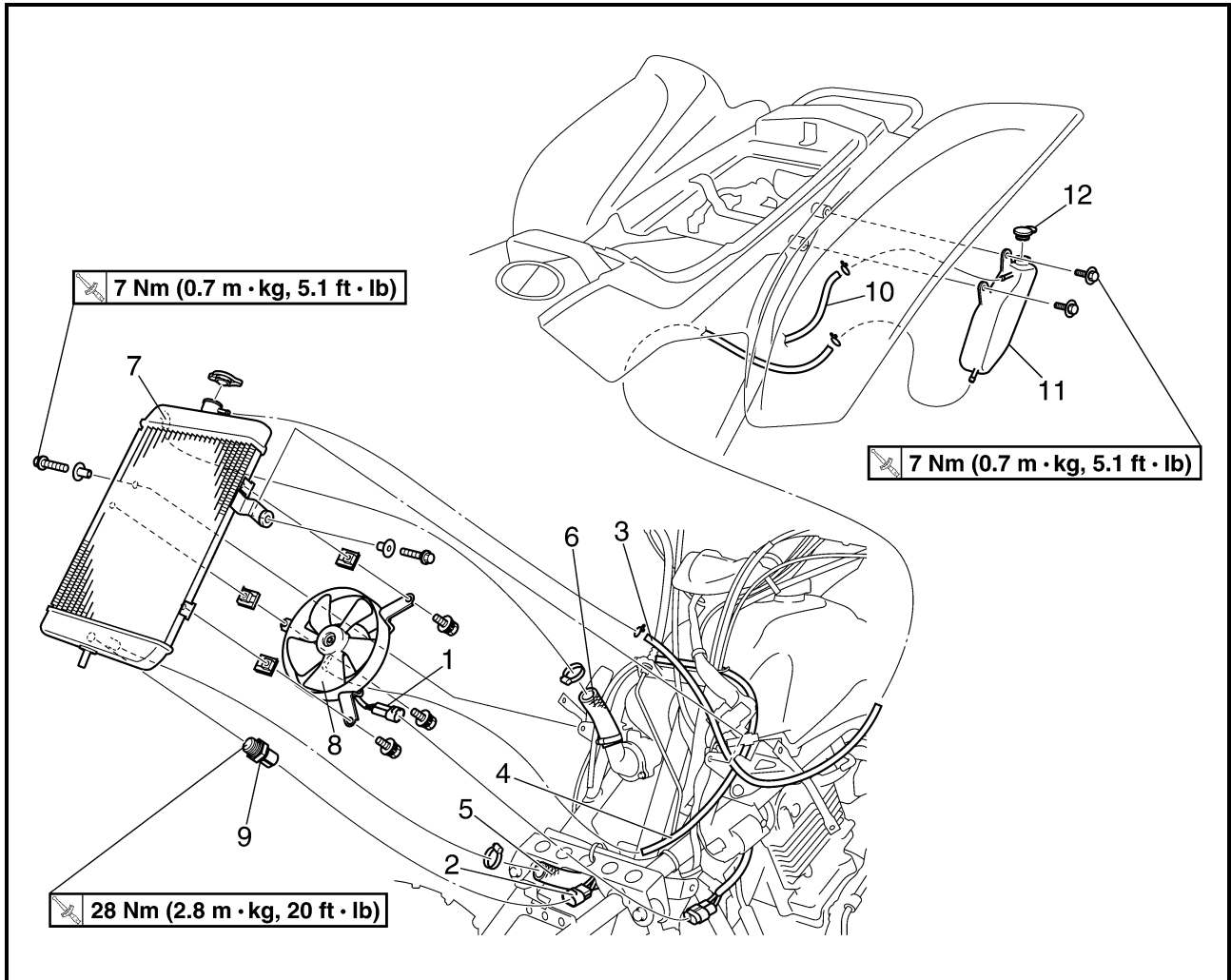

Order	Job name/Part name	Q'ty	Remarks
11	Coolant reservoir	1	For installation, reverse the removal procedure.
12	Coolant reservoir cap	1	

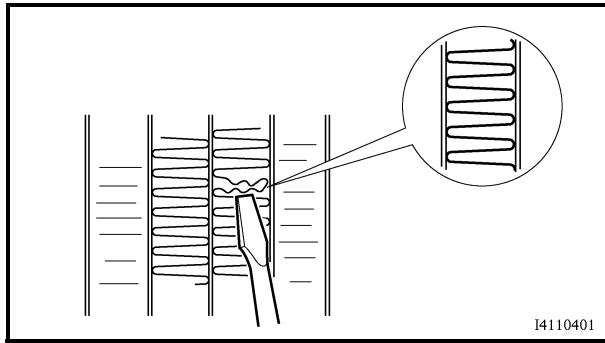

I4110401

**CHECKING THE RADIATOR**

1. Check:

- Radiator fins

Obstruction → Clean.

Apply compressed air to the rear of the radiator.

Damage → Repair or replace.

**OTE:** \_\_\_\_\_

Straighten any flattened fins with a thin, flat-head screwdriver.

2. Check:

- Radiator hoses

Cracks/damage → Replace.

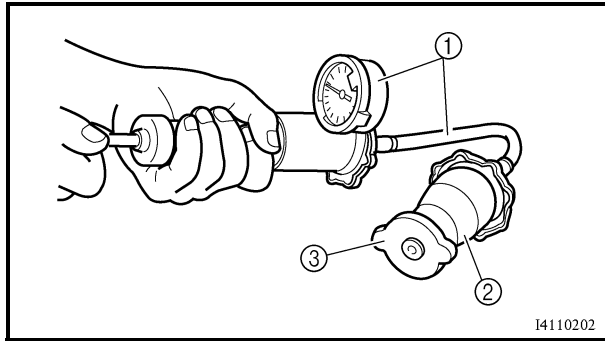

I4110202

3. Measure:

- Radiator cap opening pressure

Below the specified pressure → Replace the radiator cap.



**Radiator cap opening pressure:**  
 95 ~ 125 kPa  
 (0.95 ~ 1.25 kg/cm<sup>2</sup>,  
 13.8 ~ 18.1 psi)

\*\*\*\*\*

**Measurement steps:**

- Install the radiator cap tester ① and adapter ② onto the radiator cap ③.



**Radiator cap tester:**  
 P/N. YU-24460-01, 90890-01325  
**Adapter:**  
 P/N. YU-33984, 90890-01352

- Apply the specified pressure for ten seconds and make sure that there is no drop in pressure.

\*\*\*\*\*

4. Check:

- Radiator fan

Damage → Replace.

Malfunction → Check and repair.

Refer to “COOLING SYSTEM” in CHAPTER 9.



---

**INSTALLING THE RADIATOR****1.Fill:**

- Cooling system  
(with the specified amount of the recommended coolant)  
Refer to “CHANGING THE COOLANT” in CHAPTER 3.

**2.Check:**

- Cooling system  
Leaks → Repair or replace any faulty part.

THERMOSTAT

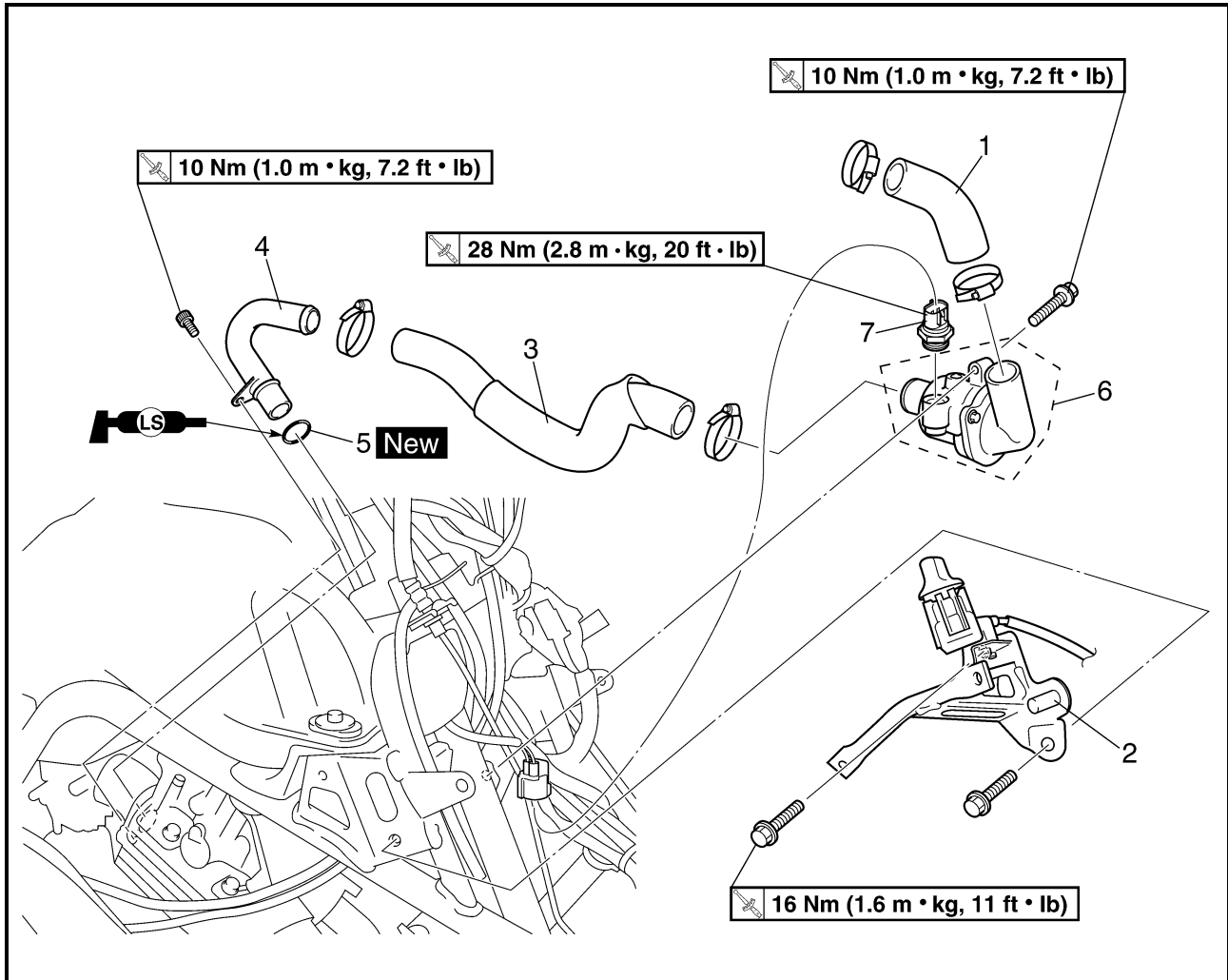

Order	Job name/Part name	Q'ty	Remarks
	<b>Removing the thermostat</b>		Remove the parts in the order below.
	Front panel and front fender		Refer to "SEAT, FENDERS AND FUEL TANK" in CHAPTER 3.
	Coolant		Drain.
	Radiator		Refer to "RADIATOR".
1	Radiator inlet hose	1	
2	Front fender bracket	1	
3	Thermostat inlet hose	1	
4	Water jacket outlet pipe	1	
5	O-ring	1	
6	Thermostat assembly	1	
7	Thermo switch 2	1	
			For installation, reverse the removal procedure.



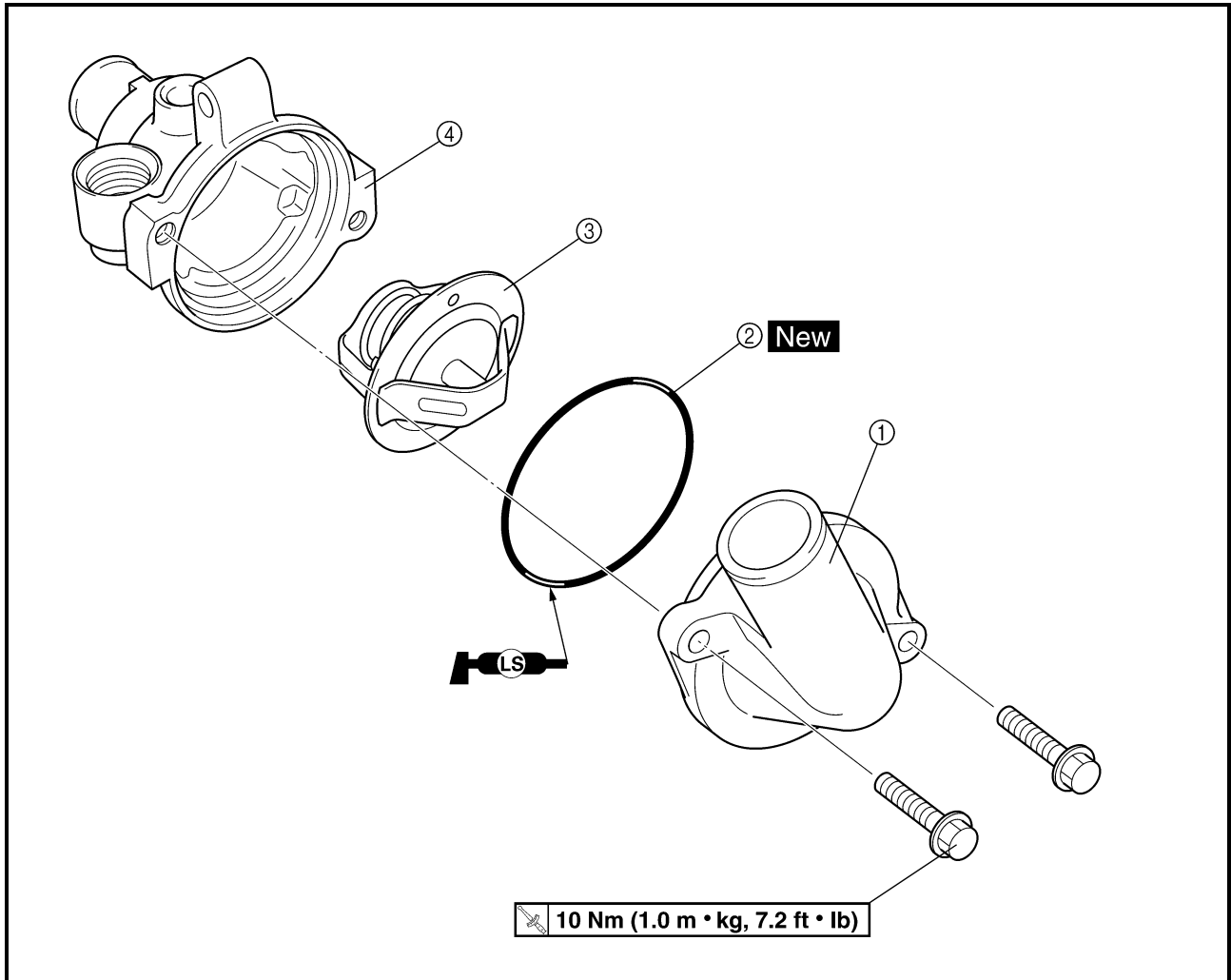

Order	Job name/Part name	Q'ty	Remarks
	<b>Disassembling the thermostat</b>		Remove the parts in the order listed.
①	Thermostat cover	1	Refer to "ASSEMBLING THE THERMOSTAT".
②	O-ring	1	
③	Thermostat	1	
④	Thermostat housing	1	
			For assembly, reverse the disassembly procedure.

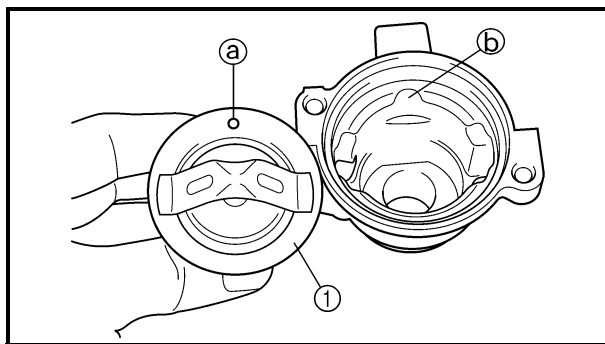
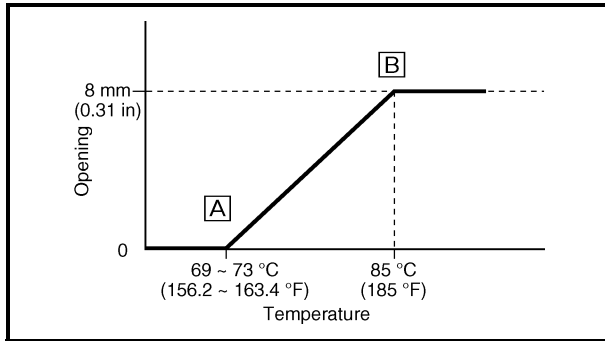
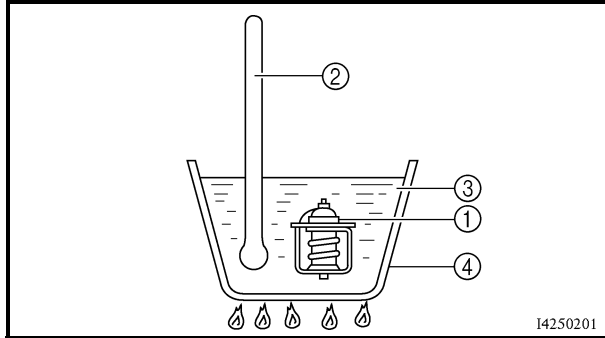
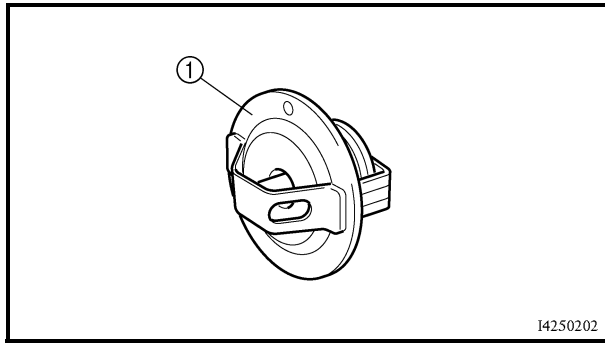

**CHECKING THE THERMOSTAT**

1. Check:

- Thermostat ①  
Does not open at 69 ~ 73 °C (156.2 ~ 163.4 °F) → Replace.

\*\*\*\*\*

**Checking steps:**

- Suspend the thermostat in a container filled with water.
- Slowly heat the water.
- Place a thermometer in the water.
- While stirring the water, observe the thermostat and thermometer's indicated temperature.

\*\*\*\*\*

- ① Thermostat
- ② Thermometer
- ③ Water
- ④ Container
- Ⓐ Fully closed
- Ⓑ Fully open

**OTE:**

\_\_\_\_\_ If the accuracy of the thermostat is in doubt, replace it. A faulty thermostat could cause serious overheating or overcooling.

2. Check:

- Thermostat housing cover
- Thermostat housing  
Cracks/damage → Replace.

**ASSEMBLING THE THERMOSTAT**

1. Install:

- Thermostat ①
- Thermostat housing cover

**OTE:**

\_\_\_\_\_ Install the thermostat with its breather hole Ⓐ toward the projection Ⓑ.

2. Fill:

- Cooling system  
(with the specified amount of the recommended coolant)  
Refer to "CHANGING THE COOLANT" in CHAPTER 3.

3. Check:

- Cooling system  
Leak → Repair or replace any faulty part.

WATER PUMP

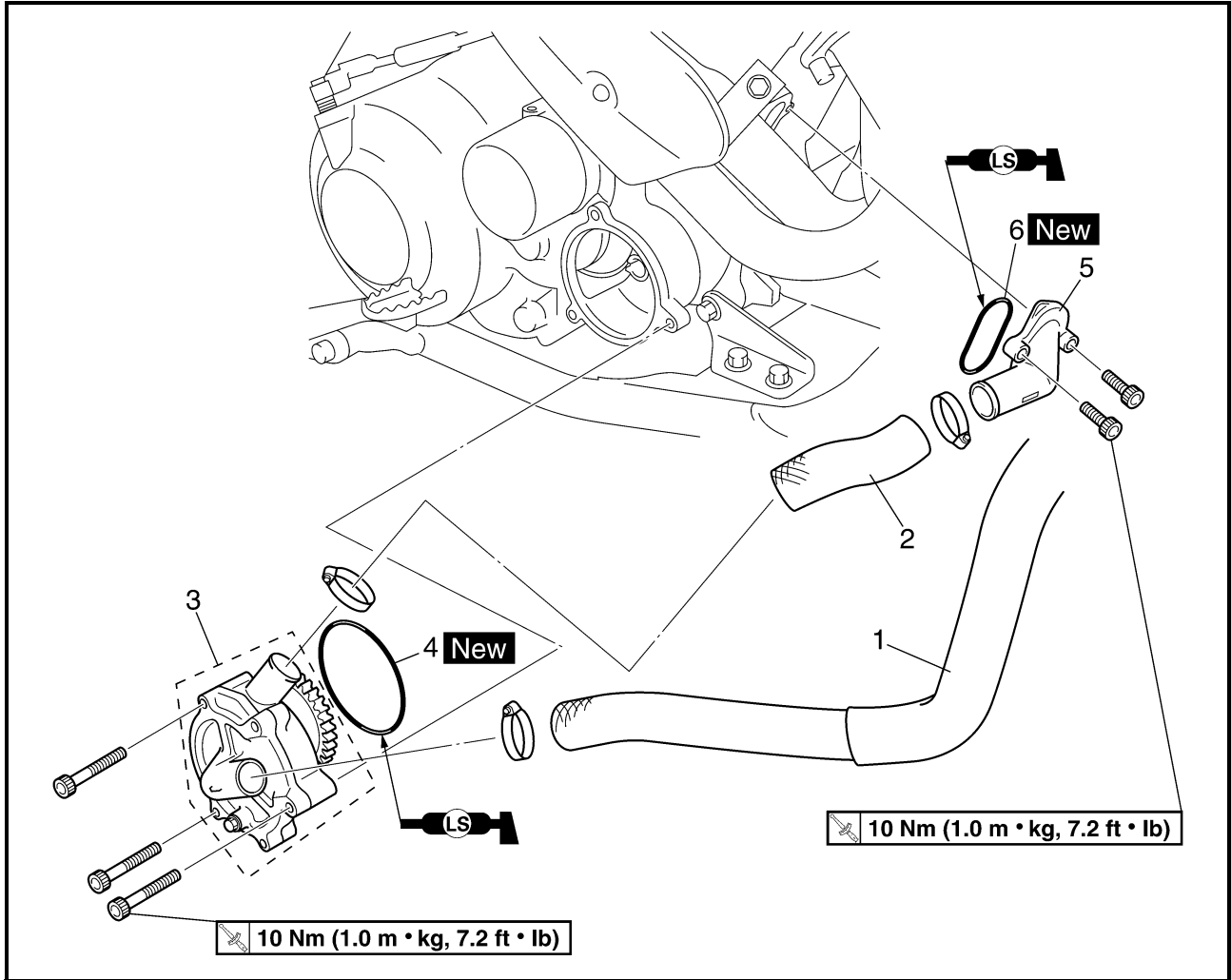

Order	Job name/Part name	Q'ty	Remarks
	<b>Removing the water pump</b>		Remove the parts in the order below.
	Coolant		Drain.
1	Radiator outlet hose	1	Disconnect.
2	Water pump outlet hose	1	
3	Water pump assembly	1	
4	O-ring	1	
5	Water jacket inlet housing	1	
6	O-ring	1	
			For installation, reverse the removal procedure.

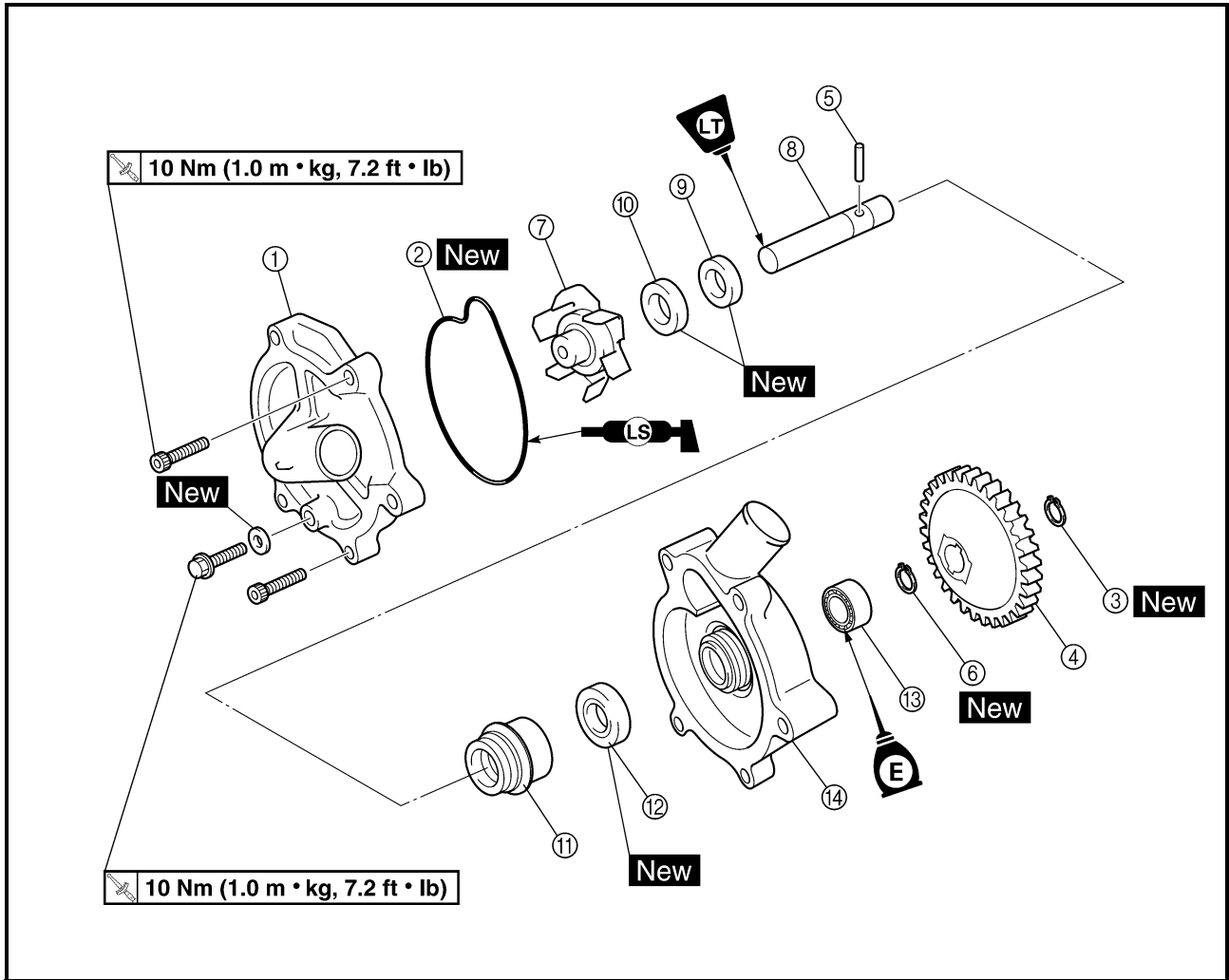

Order	Job name/Part name	Q'ty	Remarks
	<b>Disassembling the water pump</b>		Remove the parts in the order below.
①	Water pump housing cover	1	
②	O-ring	1	
③	Circlip	1	
④	Impeller shaft gear	1	
⑤	Pin	1	
⑥	Circlip	1	
⑦	Impeller	1	
⑧	Impeller shaft	1	Refer to "DISASSEMBLING/ASSEMBLING THE THERMOSTAT".
⑨	Rubber damper holder	1	

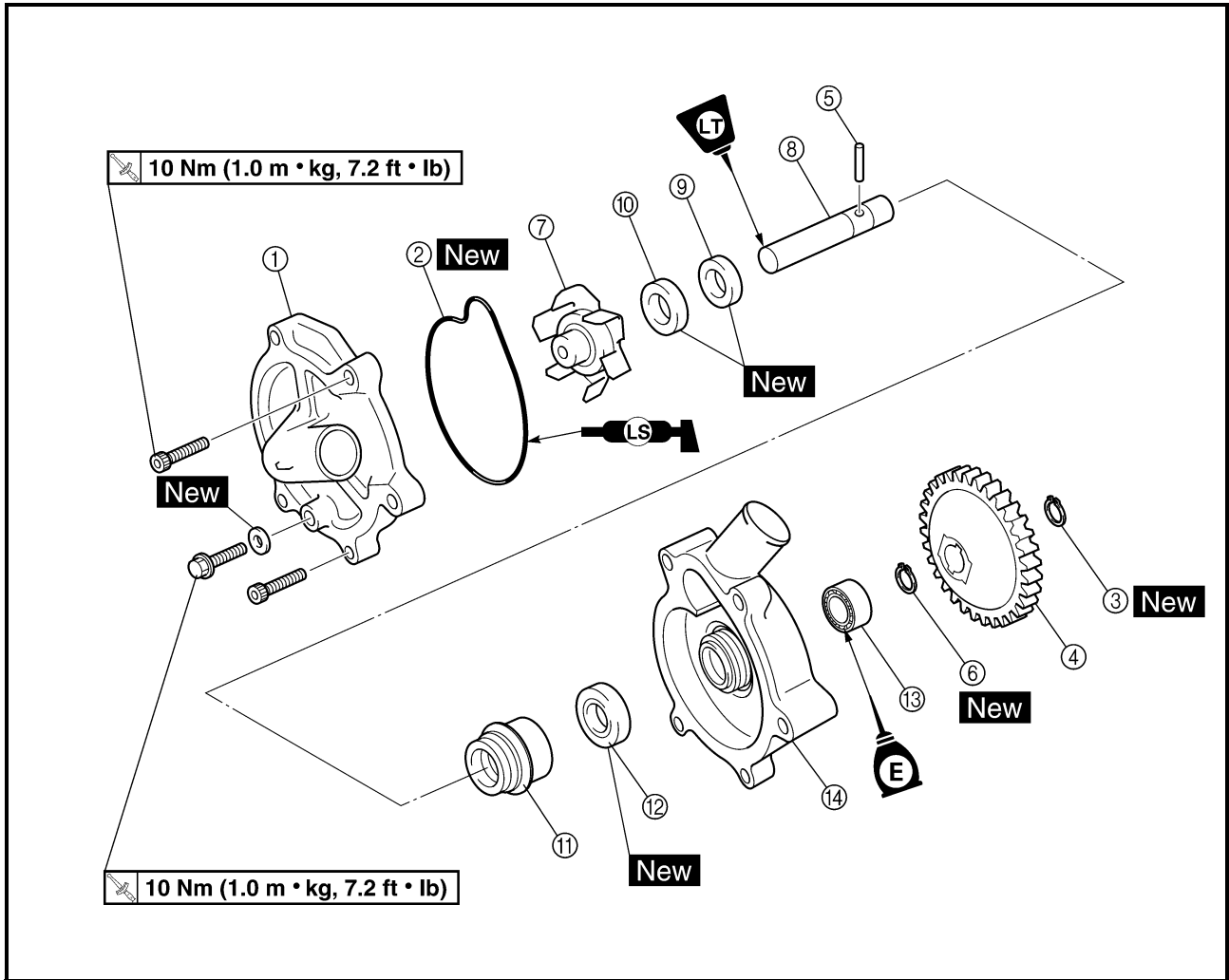

Order	Job name/Part name	Q'ty	Remarks
⑩	Rubber damper	1	Refer to "DISASSEMBLING/ASSEMBLING THE THERMOSTAT".
⑪	Water pump seal	1	
⑫	Oil seal	1	
⑬	Bearing	1	
⑭	Water pump housing	1	
			For assembly, reverse the disassembly procedure.

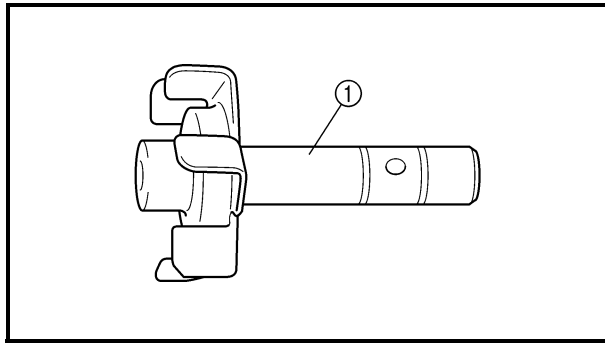

## DISASSEMBLING THE WATER PUMP

1.Remove:

- Impeller shaft ①

**OTE:** \_\_\_\_\_

Tap out the impeller shaft from the impeller.

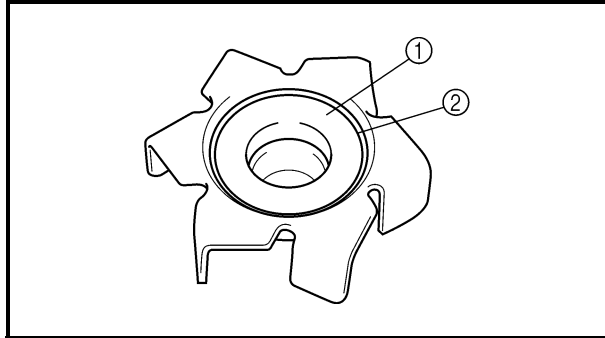

2.Remove:

- Rubber damper holder ①
- Rubber damper ②  
(from the impeller, with a thin, flathead screwdriver)

**OTE:** \_\_\_\_\_

Do not scratch the impeller.

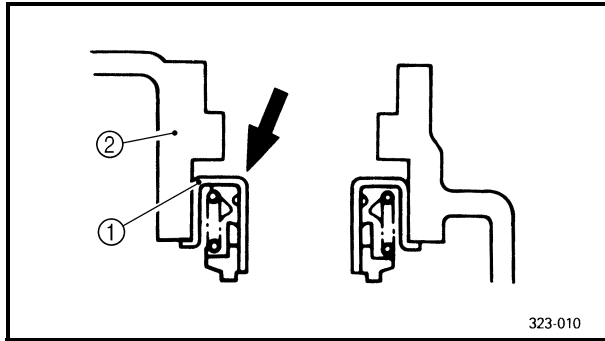

3.Remove:

- Water pump seal ①

**OTE:** \_\_\_\_\_

Tap out the water pump seal from the inside of the water pump housing.

② Water pump housing

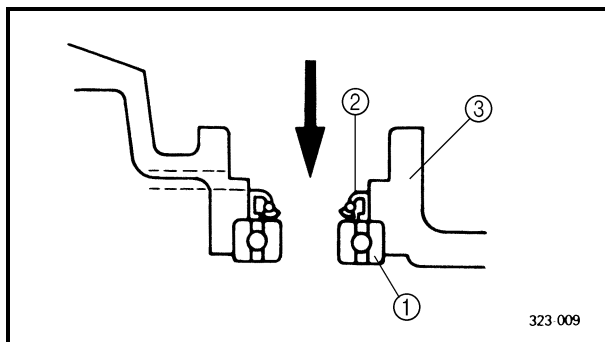

4.Remove:

- Oil seal ①
- Bearing ②

**OTE:** \_\_\_\_\_

Tap out the bearing and oil seal from the outside of the water pump housing.

③ Water pump housing

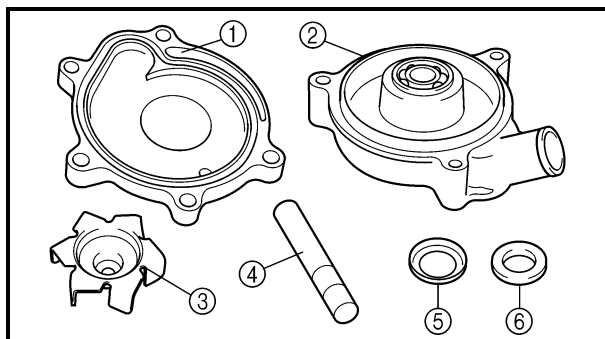

## CHECKING THE WATER PUMP

1.Check:

- Water pump housing cover ①
- Water pump housing ②
- Impeller ③
- Impeller shaft ④
- Rubber damper ⑤
- Rubber damper holder ⑥

Cracks/damage/wear → Replace.



2. Check:

- Water pump seal
- Oil seal **New**
- Water pump outlet pipe  
Cracks/damage/wear → Replace.
- Bearing  
Rough movement → Replace.

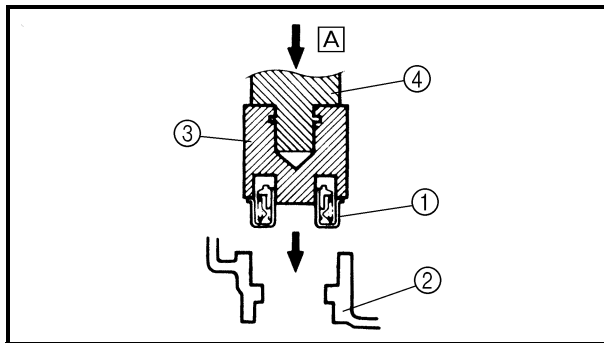
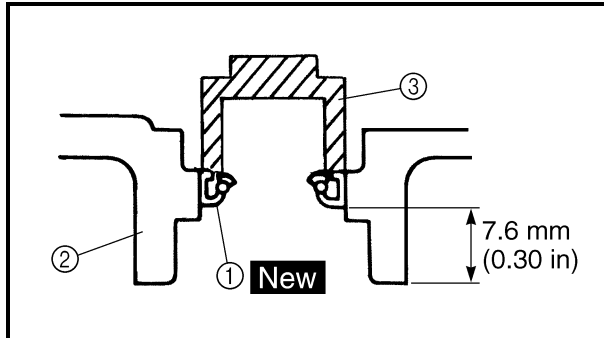

**ASSEMBLING THE WATER PUMP**

1. Install:

- Oil seal ① **New**  
(into the water pump housing ②)

**OTE:** \_\_\_\_\_

- Before installing the oil seal, apply tap water or coolant onto its outer surface.
- Install the oil seal with a socket ③ that matches its outside diameter.

2. Install:

- Water pump seal ① **New**  
(into the water pump housing ②)

**CAUTION:** \_\_\_\_\_

**Never lubricate the water pump seal surface with oil or grease.**

**OTE:** \_\_\_\_\_

Install the water pump seal with the special tools.



**Mechanical seal installer ③:**  
P/N. YM-33221, 90890-04078  
**Middle driven shaft bearing driver ④:**  
P/N. YM-04058-1, 90890-04058

**A** Push down.

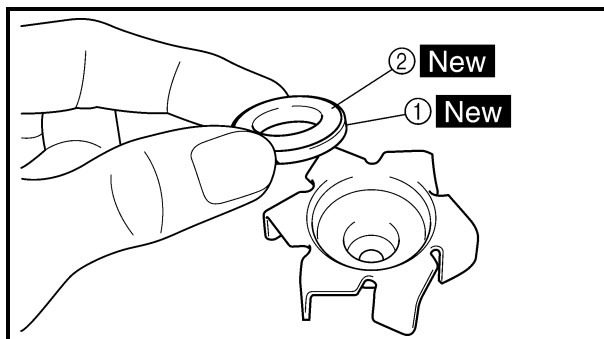

3. Install:

- Rubber damper ① **New**
- Rubber damper holder ② **New**

**OTE:** \_\_\_\_\_

Before installing the rubber damper, apply tap water or coolant onto its outer surface.

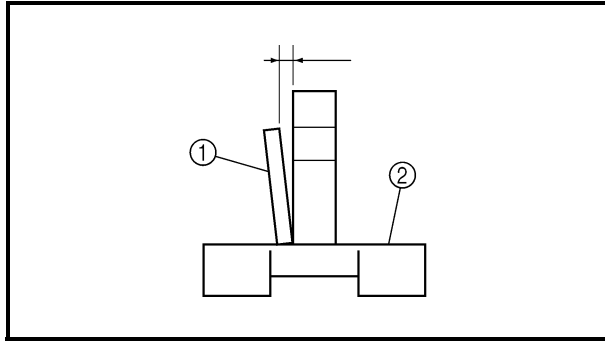

## 4.Measure:

- Impeller shaft tilt  
Out of specification → Repeat steps (3) and (4).

**CAUTION:**

Make sure that the rubber damper and rubber damper holder are bottom with the impeller.



Max. impeller shaft tilt:  
0.15 mm (0.006 in)

- ① Straightedge
- ② Impeller





CARBURETION

CARBURETORS

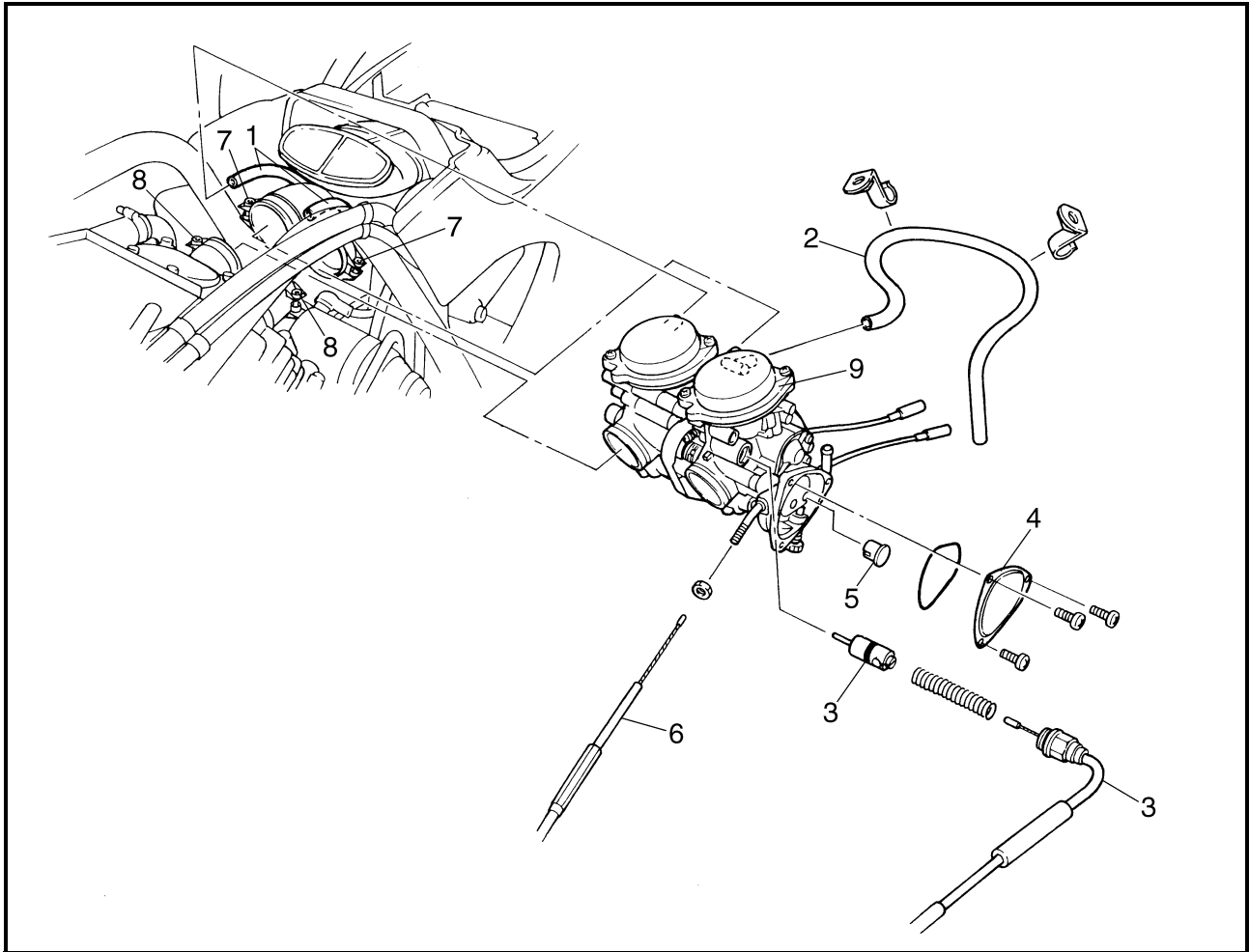

Order	Job name/Part name	Q'ty	Remarks
	<b>Removing the carburetors</b>		Remove the parts in the order below.
	Seat/front fender/fuel tank/rubber cover		Refer to "SEAT, FENDERS AND FUEL TANK" in CHAPTER 3.
2			
1	Air vent hose	2	
2	Float chamber breather hose	1	
3	Starter cable/starter plunger	1/1	
4	Throttle valve cover	1	
5	Throttle cable end	1	
6	Throttle cable	1	
7	Clamp screw (air filter case)	2	Loosen.
8	Clamp screw (carburetor joint)	2	Loosen.
9	Carburetors	1	
			For installation, reverse the removal procedure.

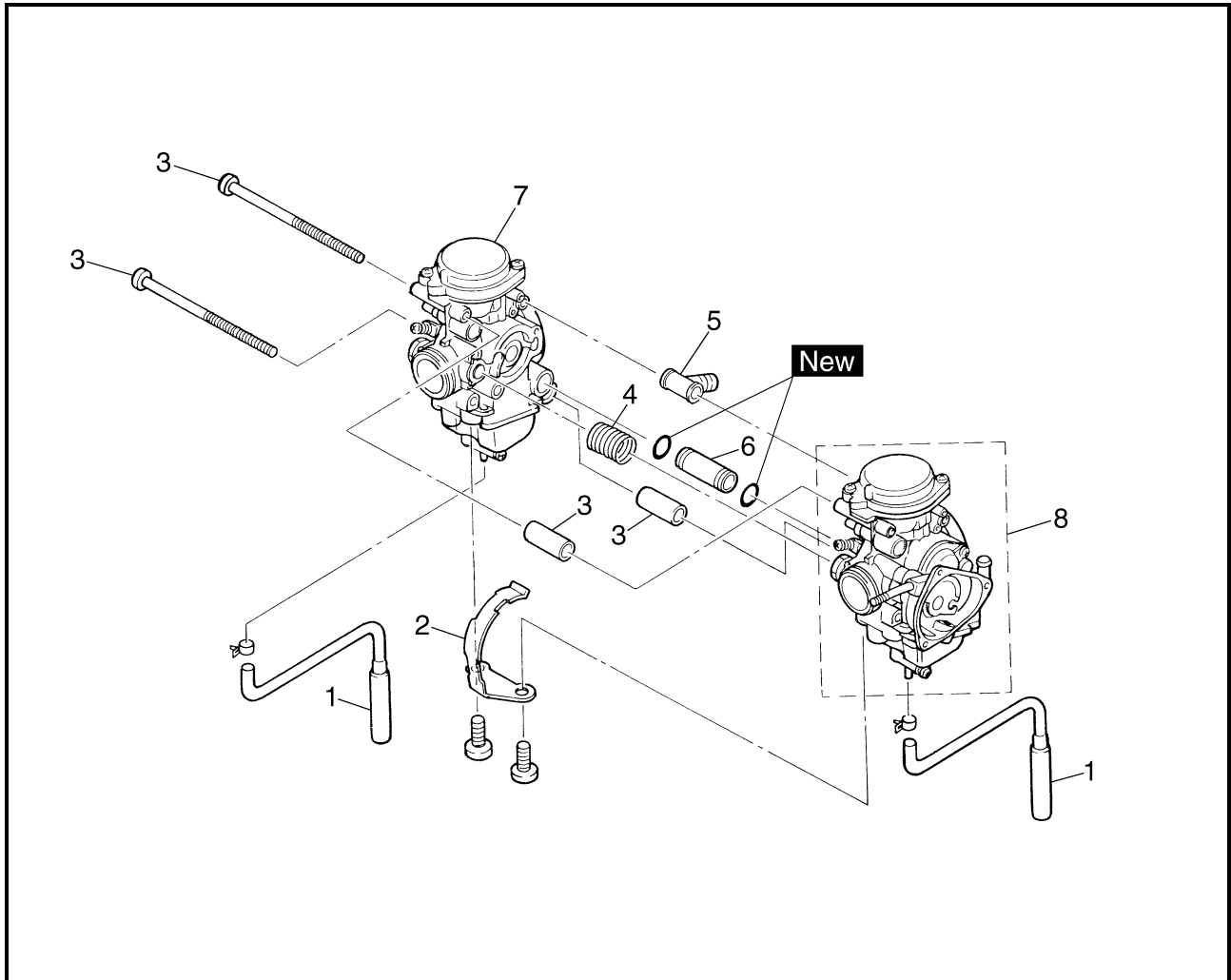

Order	Job name/Part name	Q'ty	Remarks
	<b>Separating the carburetors</b>		Remove the parts in the order below.
1	Drain hose	2	
2	Plate	1	
3	Connecting bolt/spacer	2/2	
4	Spring	1	
5	Hose joint	1	
6	Pipe	1	
7	Carburetor 2	1	
8	Carburetor 1	1	
			For installation, reverse the separating procedure.

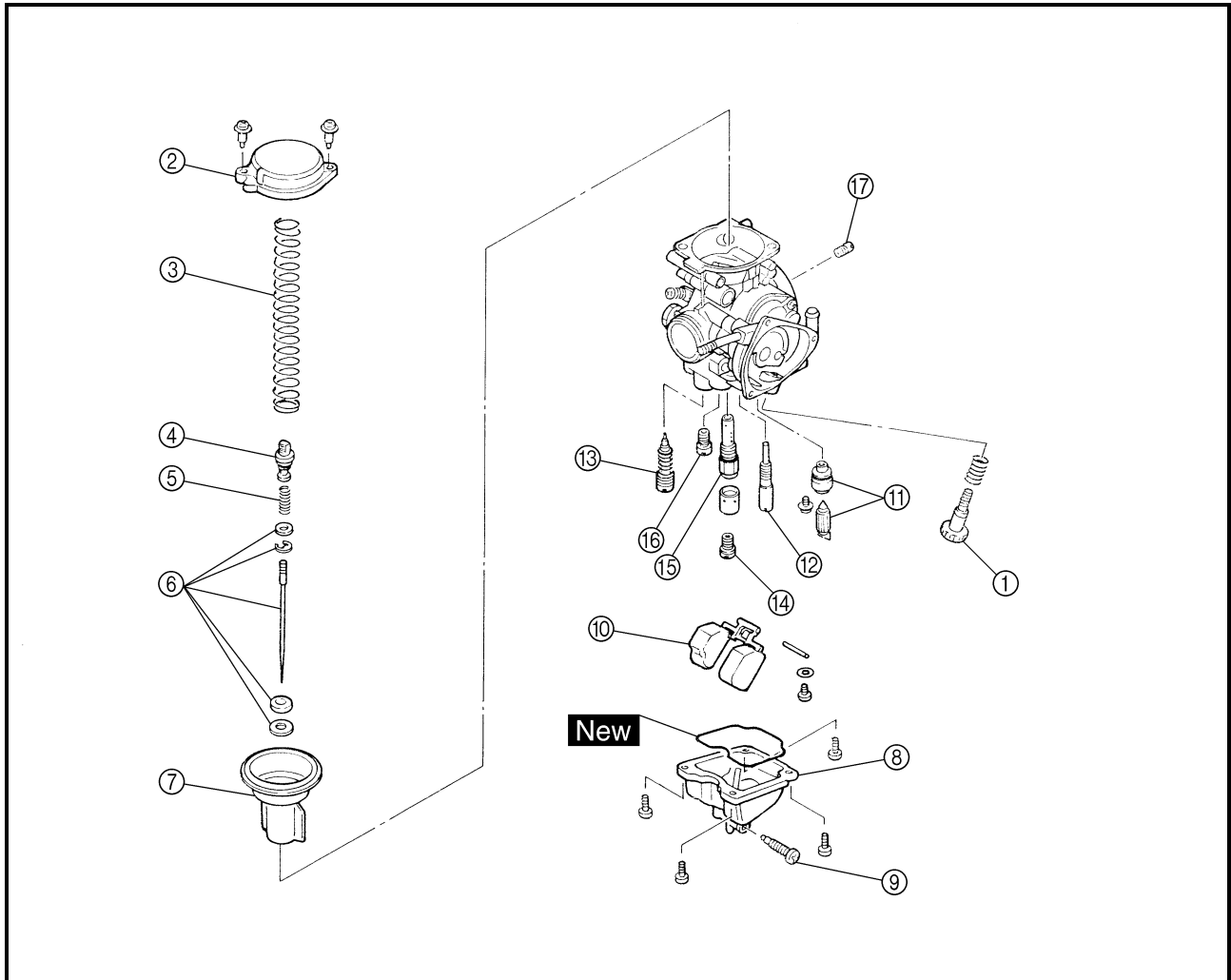

Order	Job name/Part name	Q'ty	Remarks
	<b>Disassembling the carburetor</b>		Remove the parts in the order below.
①	Throttle stop screw	1	
②	Vacuum chamber cover	1	
③	Spring	1	
④	Jet needle holder	1	
⑤	Spring	1	
⑥	Jet needle set	1	
⑦	Piston valve	1	
⑧	Float chamber	1	
⑨	Drain screw	1	
⑩	Float	1	Refer to "ASSEMBLING THE CARBURETOR".
⑪	Needle valve set	1	

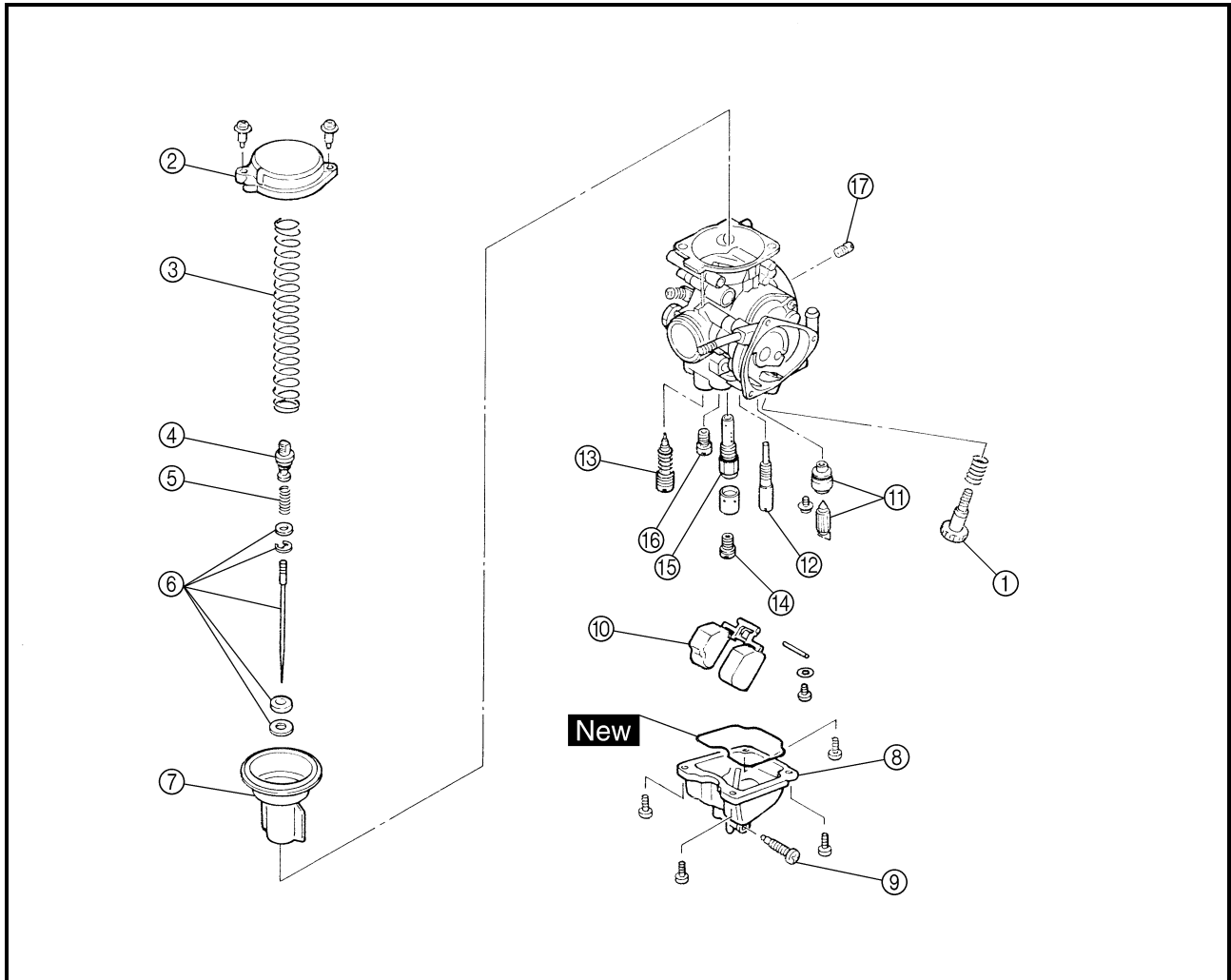

Order	Job name/Part name	Q'ty	Remarks
⑫	Pilot jet	1	Refer to "DISASSEMBLING/ ASSEMBLING THE CARBURETOR".
⑬	Pilot screw set	1	
⑭	Main jet	1	Refer to "ASSEMBLING THE CARBURE- TOR".
⑮	Needle jet	1	
⑯	Starter jet	1	For assembly, reverse the disassembly procedure.
⑰	Pilot air jet	1	



**DISASSEMBLING THE CARBURETOR**

**OTE:** \_\_\_\_\_

Before disassembling the carburetor, make sure to note the number of times the pilot screw is turned out from the seated position to its set position.

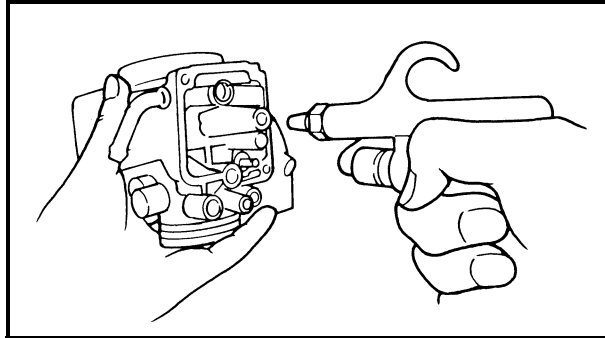

**CHECKING THE CARBURETOR**

1. Check:

- Carburetor body
- Float chamber  
Cracks/damage → Replace.
- Fuel passage  
Contamination → Clean as indicated.
- Fuel chamber body  
Contamination → Clean.

\*\*\*\*\*

**Cleaning steps:**

- Wash the carburetor in a petroleum based solvent.  
(Do not use any caustic carburetor cleaning solution.)
- Blow out all of the passages and jets with compressed air.

\*\*\*\*\*

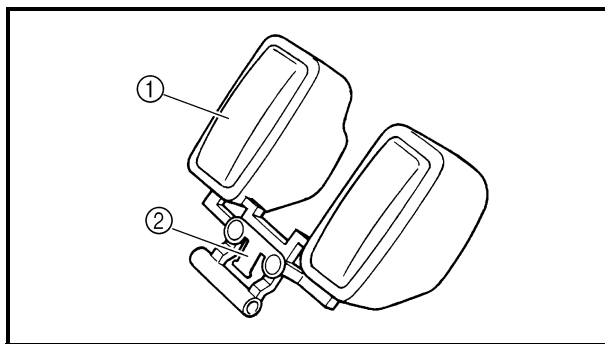

2. Check:

- Float ①
- Float tang ②  
Damage → Replace.

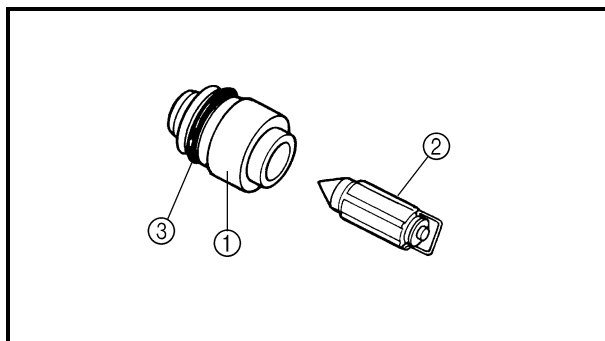

3. Check:

- Valve seat ①
- Needle valve ②
- O-ring ③  
Contamination/wear/damage → Replace as a set.

**OTE:** \_\_\_\_\_

Always replace the needle valve and valve seat as a set.

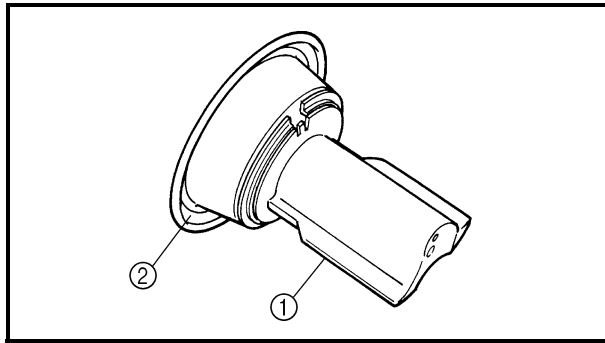

#### 4.Check:

- Piston valve ①  
Scratches/wear/damage → Replace.
- Rubber diaphragm ②  
Tears → Replace.

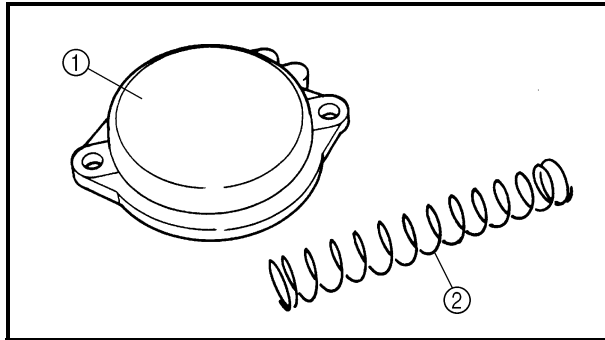

#### 5.Check:

- Vacuum chamber cover ①  
Cracks/damage → Replace.
- Spring ②

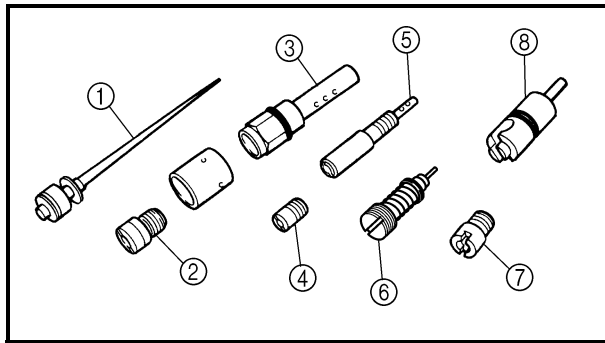

#### 6.Check:

- Jet needle ①
- Main jet ②
- Needle jet ③
- Pilot air jet ④
- Pilot jet ⑤
- Pilot screw ⑥
- Starter jet ⑦
- Starter plunger ⑧  
Bends/wear/damage → Replace.
- Blockage → Blow out the jets with compressed air.

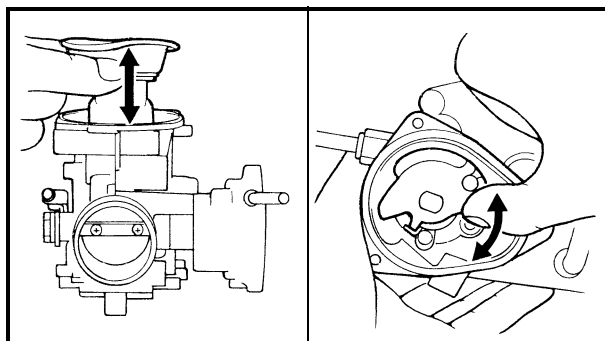

#### 7.Check:

- Free movement (piston valve)  
Sticks → Replace the piston valve guide and the piston valve.  
Insert the piston valve into the carburetor body, and check for free movement.

#### 8.Check:

- Free movement (throttle valve)  
Sticks → Replace.



ASSEMBLING THE CARBURETOR

**CAUTION:** \_\_\_\_\_

Before reassembling, wash all of the parts in a clean petroleum based solvent.

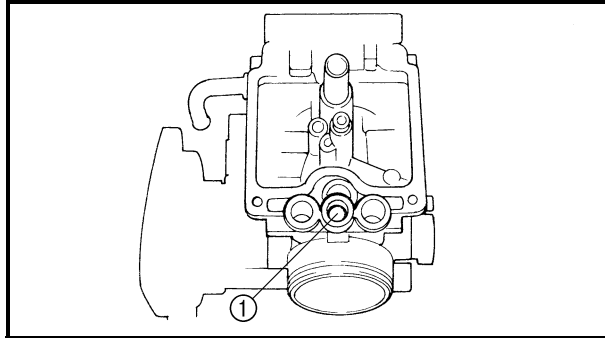

1. Install:

- Pilot screw ①

**OTE:** \_\_\_\_\_

Before assembling the carburetor, make sure to turn out the pilot screw the same number of times, as noted before disassembly, from the seated position to the set position.

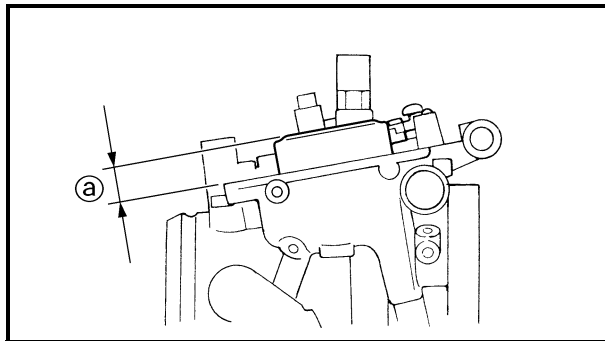

2. Measure:

- Float height ②  
Out of specification → Adjust.



**Float height (F.H.):**  
**13 mm (0.51 in)**

\*\*\*\*\*

**Measurement and adjustment steps:**

- Hold the carburetor in an upside down position.
- Measure the distance from the front mating surface of the float chamber (gasket removed) to the top of the float.

**OTE:** \_\_\_\_\_

The float arm should be resting on the needle valve, but not compressing it.

- If the float height is not within the specification, inspect the valve seat and needle valve.
- If either is worn, replace them both.
- If both are fine, adjust the float height by bending the float tang ① on the float.
- Recheck the float height.

\*\*\*\*\*

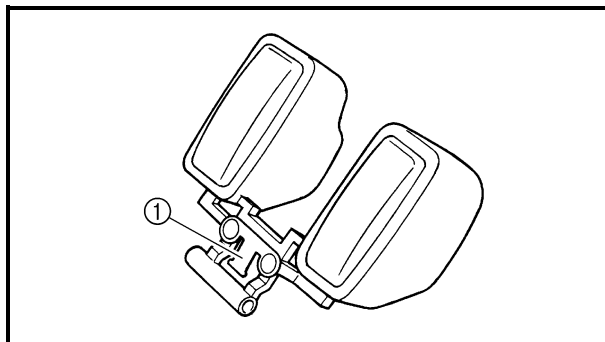

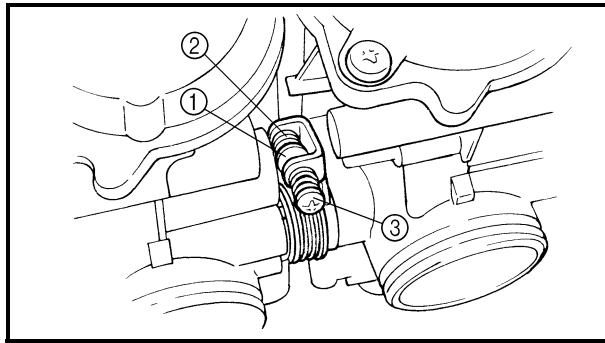

**3.Install:**

- Carburetor 1
- Carburetor 2
- Pipe
- Hose joint
- Spring

**OTE:**

- Install the throttle valve lever ① onto carburetor 2 between the spring ② and synchronizing screw ③.
- Make sure the throttle valves operate smoothly and that the synchronization is correct.

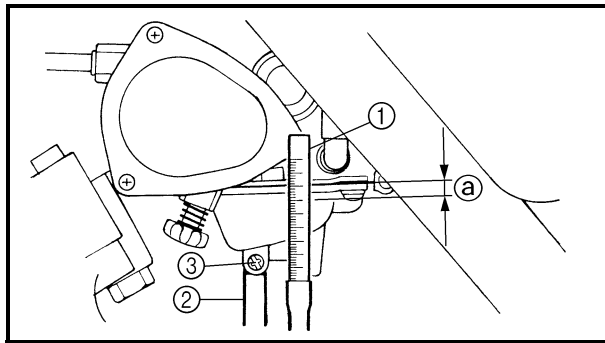

**ADJUSTING THE FUEL LEVEL**

**1.Measure:**

- Fuel level ①
- Out of specification → Adjust.



**Fuel level:**  
**3 ~ 4 mm (0.12 ~ 0.16 in)**  
**Below the float chamber mating surface**

\*\*\*\*\*

**Fuel level measurement and adjustment steps:**

- Place the machine on a level surface.
- Connect the fuel level gauge ① to the drain pipe ②.



**Fuel level gauge:**  
**P/N. YM-01312-A, 90890-01312**

- Loosen the drain screw ③.
- Hold the gauge vertically next to the float chamber line.
- Measure the fuel level ① with the gauge.
- If the fuel level is incorrect, adjust the fuel level.



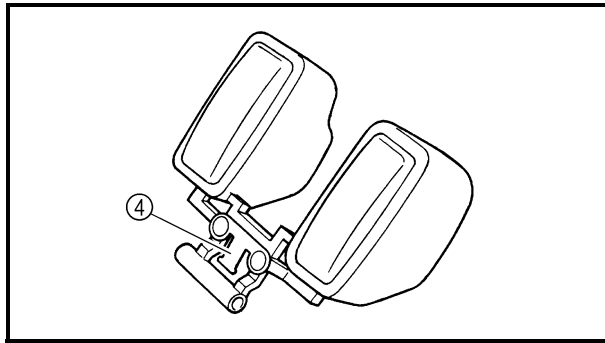

- Remove the carburetor.
- Inspect the valve seat and needle valve.
- If either is worn, replace them both.
- If both are fine, adjust the float level by bending the float tang ④ slightly.
- Install the carburetor.
- Recheck the fuel level.

\*\*\*\*\*

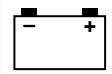

EB800000

## ELECTRICAL

## ELECTRICAL COMPONENTS

- |                           |                       |                     |
|---------------------------|-----------------------|---------------------|
| ① Main switch             | ⑨ Starter relay       | ⑰ Rear brake switch |
| ② Front brake switch      | ⑩ Tail/brake light    | ⑱ Ignition coil     |
| ③ Indicator light         | ⑪ Rectifier/regulator | ⑲ Headlight         |
| ④ Circuit breaker (fan)   | ⑫ CDI unit            | ⑳ Thermo switch 1   |
| ⑤ Park switch             | ⑬ Battery             | ㉑ Fan               |
| ⑥ Clutch switch           | ⑭ Neutral switch      | ㉒ Thermo switch 2   |
| ⑦ Handlebar switch (left) | ⑮ Reverse switch      | ㉓ Diode             |
| ⑧ Fuse                    | ⑯ Speed sensor        |                     |

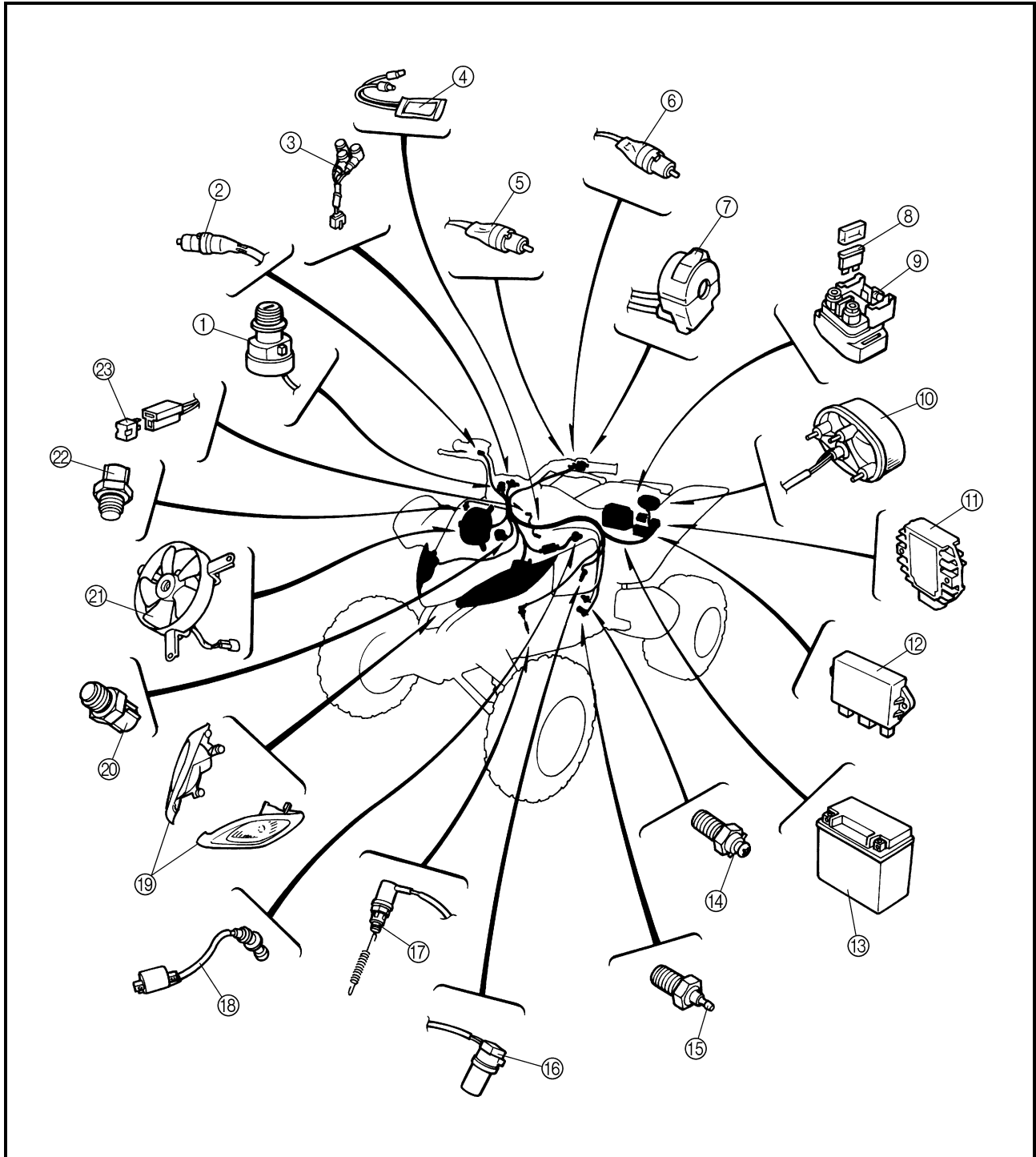

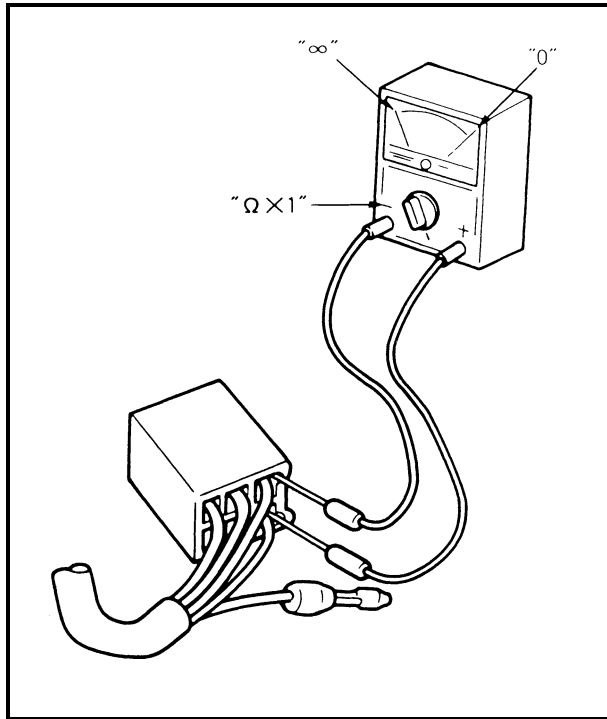
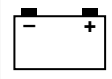

**CHECKING THE SWITCH**

**CHECKING THE SWITCH**

Use a pocket tester to check the terminals for continuity. If the continuity is faulty at any point, replace the switch.



**Pocket tester:**

**P/N. YU-03112, 90890-03112**

**OTE:**

- Set the pocket tester to "0" before starting the test.
- The pocket tester should be set to the "Ω × 1" range when testing the switch for continuity.
- Turn the switch on and off a few times when checking it.

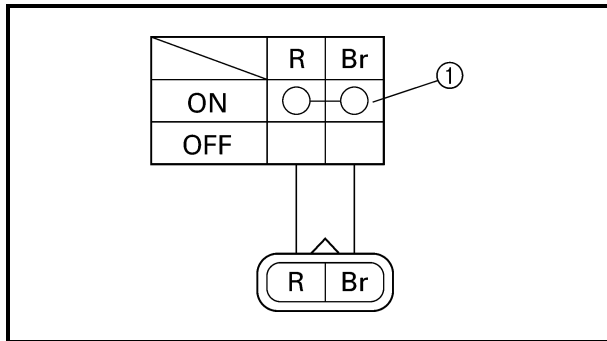

**CHECKING A SWITCH SHOWN IN THE MANUAL**

The terminal connections for switches (main switch, handlebar switch, engine stop switch, light switch, etc.) are shown in a chart similar to the one on the left.

This chart shows the switch positions in the column and the switch lead colors in the top row.

For each switch position, "○—○" indicates the terminals with continuity.

**The example chart shows that:**

- ① There is continuity between the "Red and Brown" leads when the switch is set to "ON".

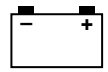

## CHECKING THE SWITCH CONTINUITY

Refer to "CHECKING THE SWITCH" and check for continuity between lead terminals.

Poor connection, no continuity → Correct or replace.

\* The coupler locations are circled.

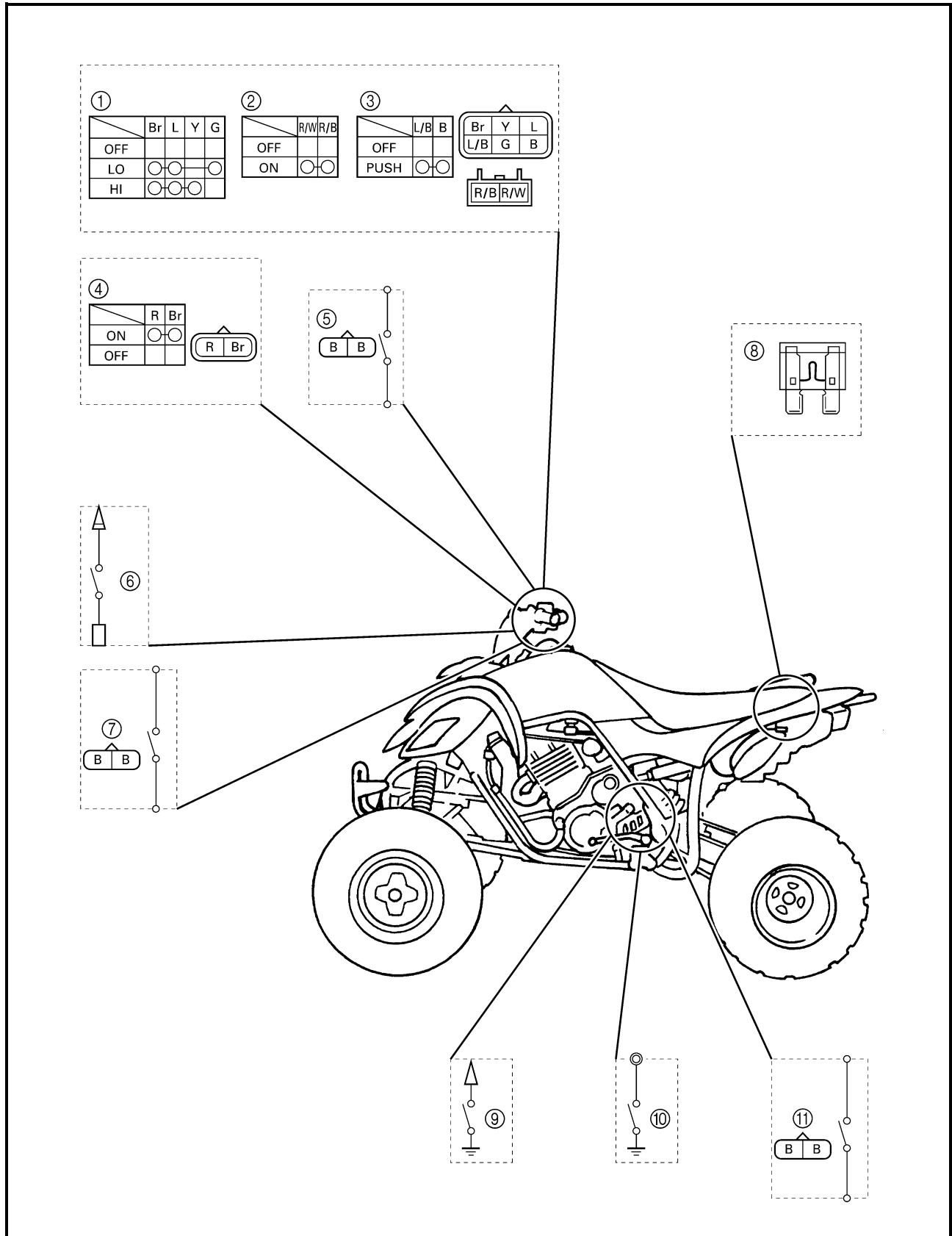

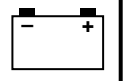

- ① Lights switch
- ② Engine stop switch
- ③ Start switch
- ④ Main switch
- ⑤ Front brake switch
- ⑥ Clutch switch
- ⑦ Park switch
- ⑧ Fuse
- ⑨ Reverse switch
- ⑩ Neutral switch
- ⑪ Rear brake switch

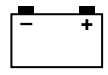

EB802000

**IGNITION SYSTEM  
CIRCUIT DIAGRAM**

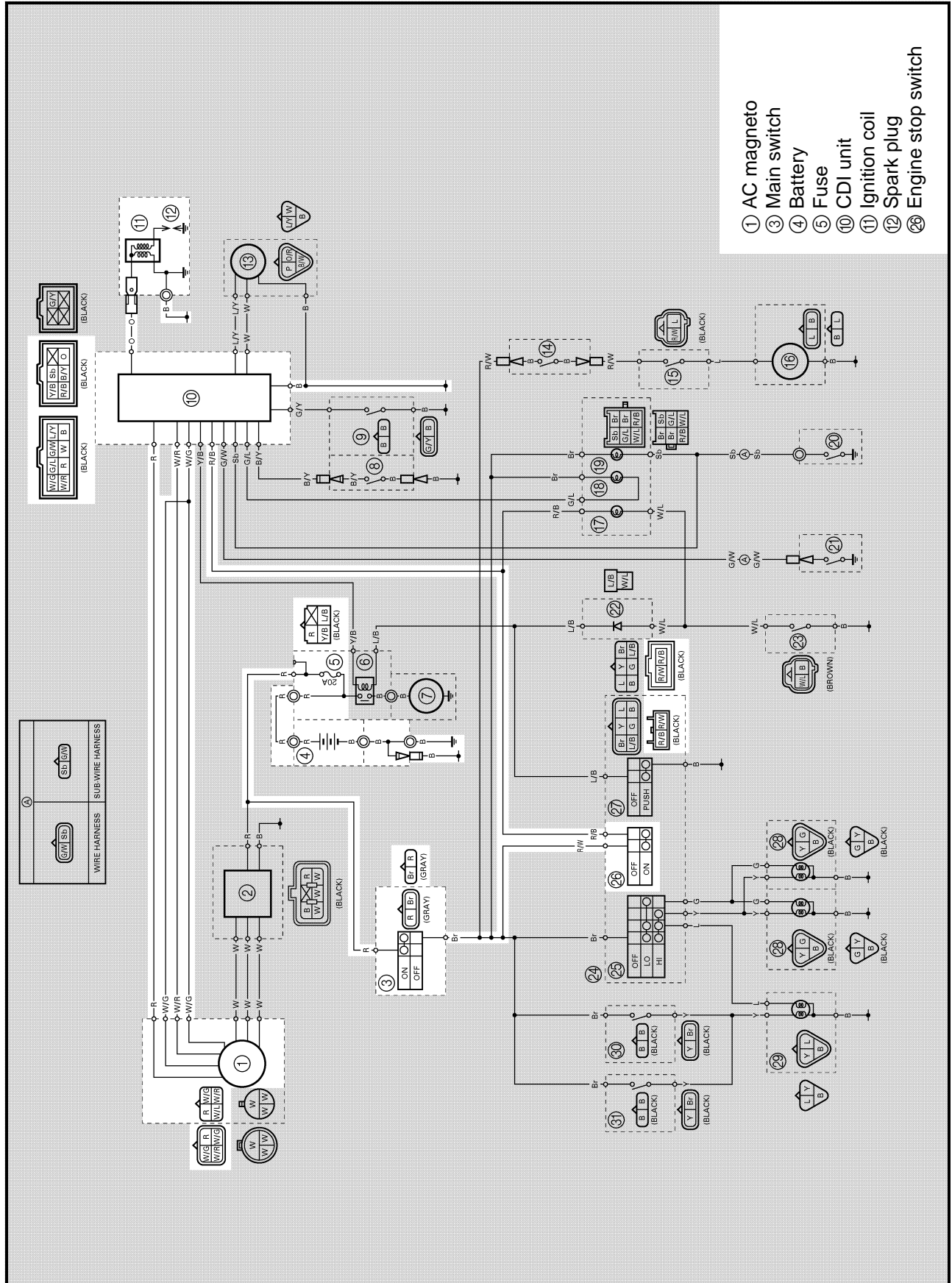

- ① AC magneto
- ③ Main switch
- ④ Battery
- ⑤ Fuse
- ⑩ CDI unit
- ⑪ Ignition coil
- ⑫ Spark plug
- ⑳ Engine stop switch

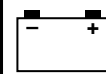

EB802010  
TROUBLESHOOTING

**IF THE IGNITION SYSTEM FAILS TO OPERATE (NO SPARK OR INTERMITTENT SPARK):**

**Procedure**

Check:

- |  |  |
|--|--|
| <ol style="list-style-type: none"> <li>1.Fuse</li> <li>2.Battery</li> <li>3.Spark plug</li> <li>4.Ignition spark gap</li> <li>5.Spark plug cap resistance</li> <li>6.Ignition coil resistance</li> </ol> | <ol style="list-style-type: none"> <li>7.Engine stop switch</li> <li>8.Main switch</li> <li>9.Pickup coil resistance</li> <li>10.Charging/rotor rotation direction detection coil resistance</li> <li>11.Wiring connection (the entire ignition system)</li> </ol> |
|--|--|

**OTE:** \_\_\_\_\_

- Remove the following part(s) before troubleshooting:
  - 1)Seat
  - 2)Front fender
- Use the following special tool(s) for troubleshooting.



**Dynamic spark tester:**  
P/N. YM-34487  
**Ignition checker:**  
P/N. 90890-06754  
**Pocket tester:**  
P/N. YU-03112, 90890-03112

EB802011

1.Fuse  
Refer to "CHECKING THE SWITCH".



EB802012

2.Battery

- Check the battery condition. Refer to "CHECKING THE BATTERY" in CHAPTER 3.

**Open-circuit voltage:**  
**12.8 V or more at 20 °C (68 °F)**

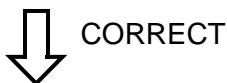

3.Spark plug

- Check the spark plug condition.
- Check the spark plug type.
- Check the spark plug gap. Refer to "CHECKING THE SPARK PLUG" in CHAPTER 3.

NO CONTINUITY



Replace the fuse.

INCORRECT



- Clean the battery terminals.
- Recharge or replace the battery.

**Standard spark plug:**  
**DPR8EA-9/NGK**

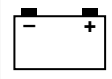

 **Spark plug gap:**  
0.8 ~ 0.9 mm (0.031 ~ 0.035 in)

↓ CORRECT

INCORRECT



Repair or replace the spark plug.

For USA and CDN

4. Ignition spark gap

- Disconnect the spark plug cap from the spark plug.
- Connect the dynamic spark tester ① as shown.
- ② Spark plug cap
- ③ Spark plug
- Turn the main switch to "ON".
- Check the ignition spark gap.
- Crank the engine by pushing the starter switch, and increase the spark gap until a misfiring occurs.

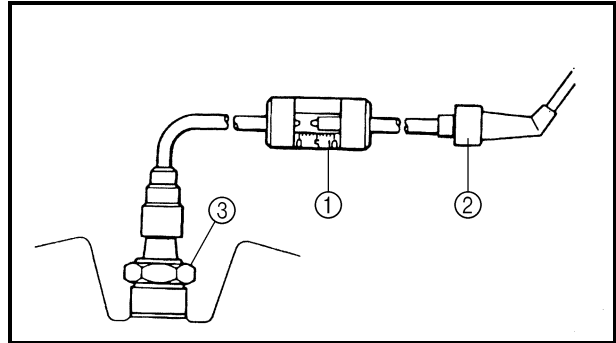

MEETS SPECIFICATION

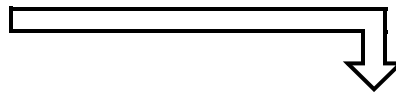

The ignition system is not faulty.

 **Minimum spark gap:**  
6.0 mm (0.24 in)

For Europe

4. Ignition spark gap

- Disconnect the spark plug cap from the spark plug.
- Connect the ignition checker ① as shown.
- ② Spark plug cap
- Turn the main switch to "ON".
- Check the ignition spark gap ③.
- Crank the engine by pushing the starter switch, and increase the spark gap until a misfiring occurs.

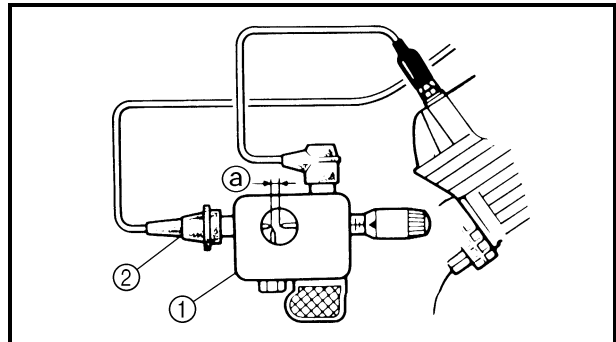

MEETS SPECIFICATION

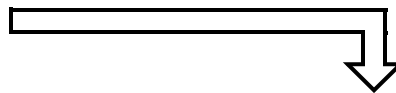

The ignition system is not faulty.

 **Minimum spark gap:**  
6.0 mm (0.24 in)

↓ OUT OF SPECIFICATION OR NO SPARK  
\*



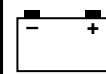

5. Spark plug cap resistance

- Remove the spark plug cap.
- Connect the pocket tester ( $\Omega \times 1k$ ) to the spark plug cap.

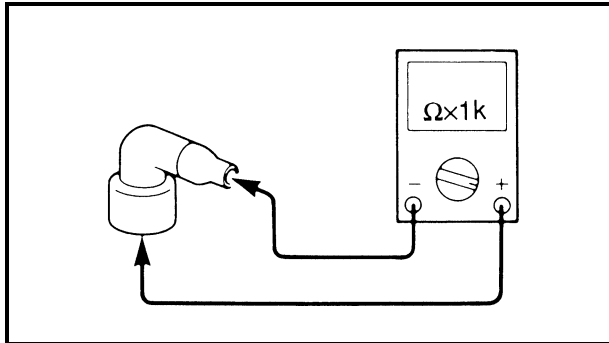

- Check that the spark plug cap has the specified resistance.

**Spark plug cap resistance:**  
10 k $\Omega$  at 20 °C (68 °F)

MEETS SPECIFICATION

OUT OF SPECIFICATION

Replace the spark plug cap.

6. Ignition coil resistance

- Disconnect the ignition coil connector from the wire harness.
- Connect the pocket tester ( $\Omega \times 1$ ) to the ignition coil.

**Tester (+) lead → Orange lead terminal**  
**Tester (-) lead → Ignition coil base**

- Check that the primary coil has the specified resistance.

**Primary coil resistance:**  
0.18 ~ 0.28  $\Omega$  at 20 °C (68 °F)

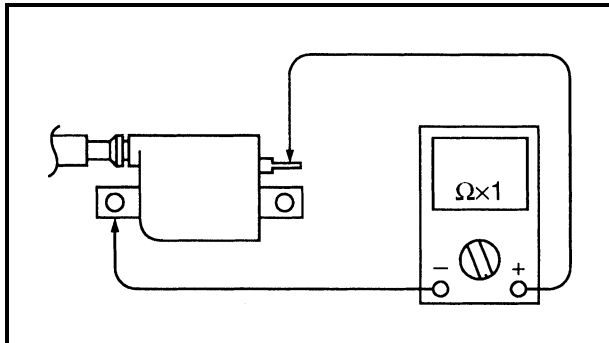

# IGNITION SYSTEM

**ELEC**

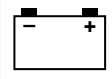

- Connect the pocket tester ( $\Omega \times 1k$ ) to the ignition coil.

**Tester (+) lead** → Orange lead terminal  
**Tester (-) lead** → Spark plug lead

- Check that the secondary coil has the specified resistance.



**Secondary coil resistance:**  
 6.32 ~ 9.48 k $\Omega$  at 20 °C (68 °F)

↓ BOTH MEET SPECIFICATION

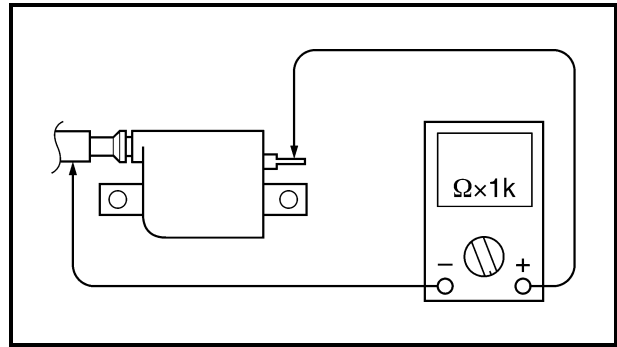

Replace the ignition coil.

7.Engine stop switch

Refer to "CHECKING THE SWITCH".

↓ CORRECT

INCORRECT

Replace the handlebar switch (left).

8.Main switch

Refer to "CHECKING THE SWITCH".

↓ CORRECT

INCORRECT

Replace the main switch.

9.Pickup coil resistance

- Disconnect the AC magneto coupler from the wire harness.
- Connect the pocket tester ( $\Omega \times 100$ ) to the pickup coil terminal.

**Tester (+) lead** → White/Red terminal ①  
**Tester (-) lead** → White/Green terminal ②

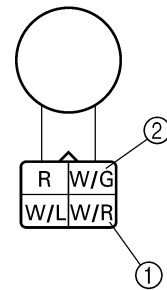
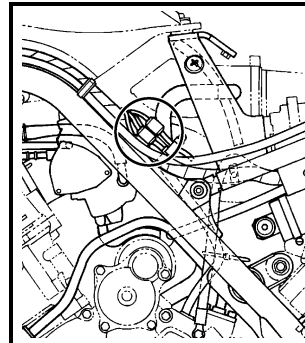

- Check the pickup coil for the specified resistance.



**Pickup coil resistance:**  
 445 ~ 545  $\Omega$  at 20 °C (68 °F)  
 (White/Red – White/Green)

↓ MEETS SPECIFICATION  
 \*

OUT OF SPECIFICATION

Replace the pickup coil/starter assembly.

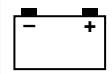

10. Charging/rotor rotation direction detection coil resistance

- Disconnect the AC magneto coupler from the wire harness.
- Connect the pocket tester ( $\Omega \times 100$ ) to the charging/rotor rotation direction detection coil terminal.

**Tester (+) lead → Red terminal ①**  
**Tester (-) lead → White/Blue terminal ②**

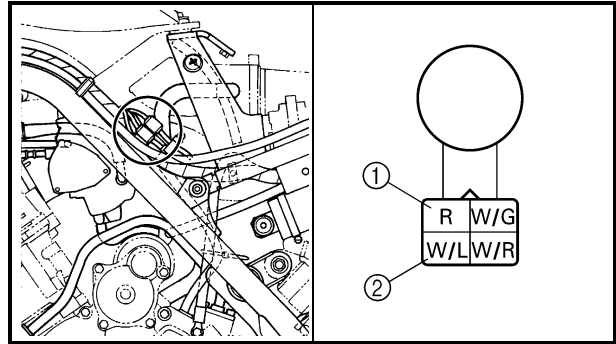

- Check the charging/rotor rotation direction detection coil for the specified resistance.



**Rotor rotation direction detection coil resistance:**  
**0.069 ~ 0.085  $\Omega$  at 20 °C (68 °F)**  
**(Red – White/Blue)**

OUT OF SPECIFICATION

Replace the pickup coil/stator assembly.

MEETS SPECIFICATION

11. Wiring connection

- Check the connections of the entire ignition system. Refer to "CIRCUIT DIAGRAM".

POOR CONNECTION

Properly connect the ignition system.

CORRECT

Replace the CDI unit.

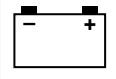

EB803000

## ELECTRIC STARTING SYSTEM

### CIRCUIT DIAGRAM

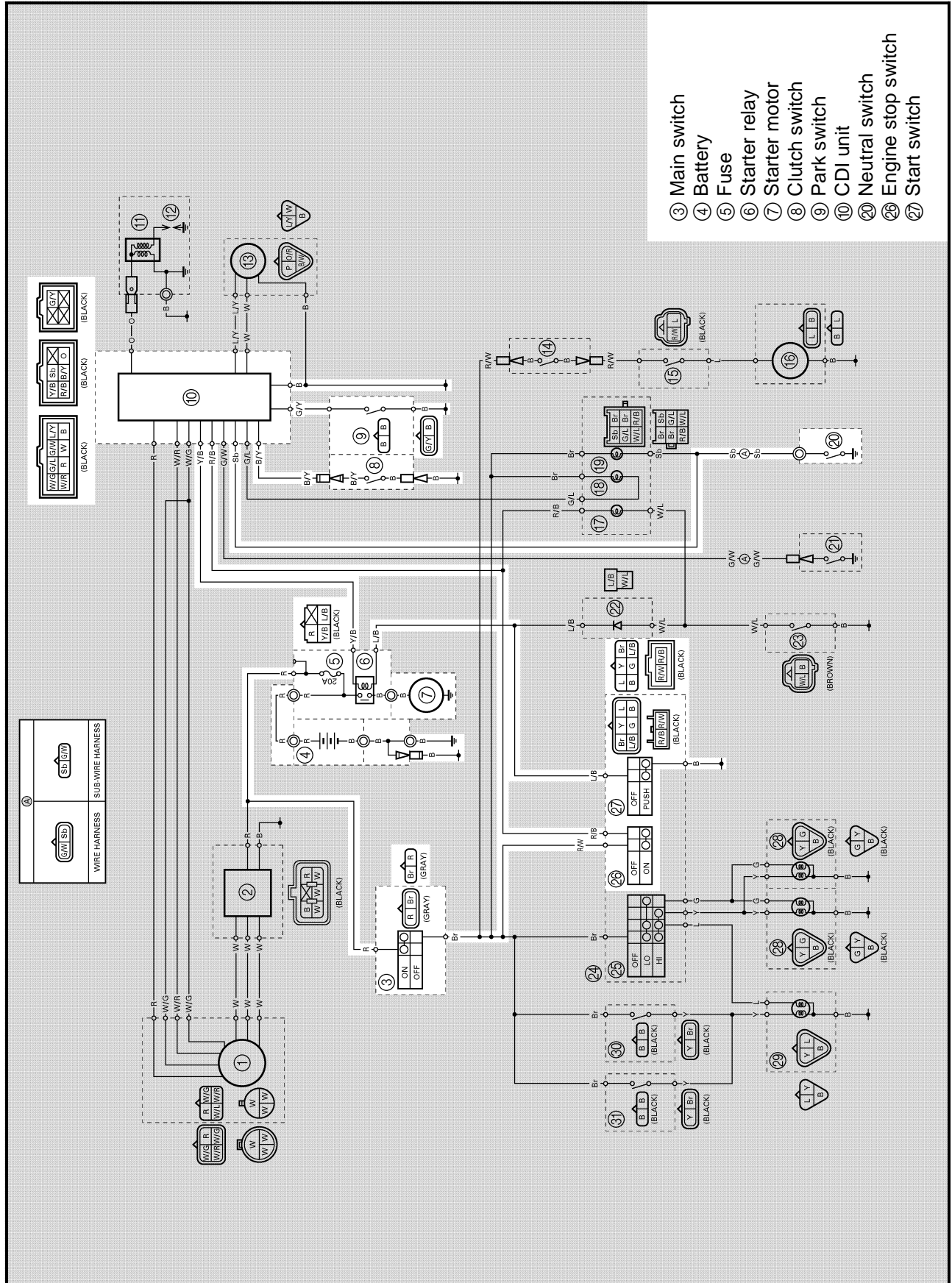

- ③ Main switch
- ④ Battery
- ⑤ Fuse
- ⑥ Starter relay
- ⑦ Starter motor
- ⑧ Clutch switch
- ⑨ Park switch
- ⑩ CDI unit
- ⑲ Neutral switch
- ⑳ Engine stop switch
- ㉑ Start switch

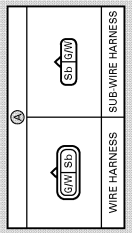

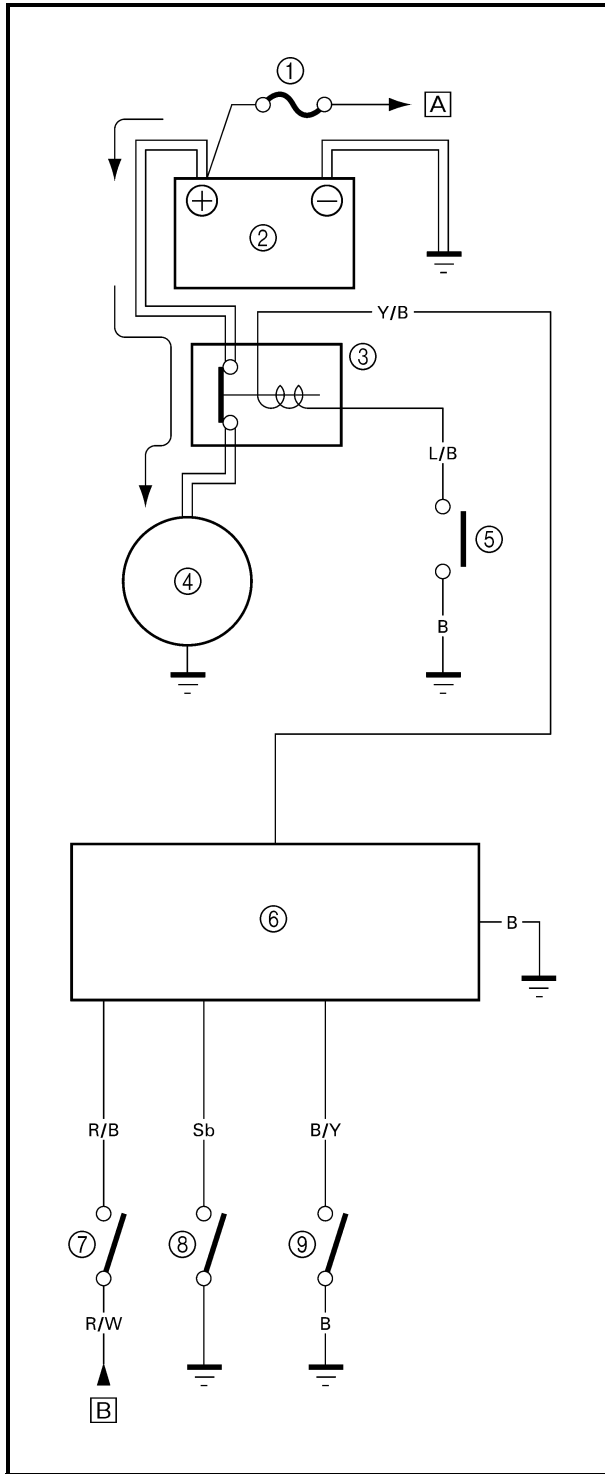
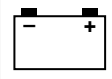

**STARTING CIRCUIT OPERATION**

The starting circuit on this model consists of the starter motor, starter relay, clutch switch, CDI unit and neutral switch. If the main switch is on and the engine stop switch is in the RUN position, the starter motor can be operated only if:

- The transmission is in neutral (the neutral switch is closed).
- or**
- You pull in the clutch lever (the clutch switch is closed).

- ① Fuse
- ② Battery
- ③ Starter relay
- ④ Starter motor
- ⑤ Start switch
- ⑥ CDI unit
- ⑦ Engine stop switch
- ⑧ Neutral switch
- ⑨ Clutch switch
- Ⓐ TO MAIN SWITCH
- Ⓑ FROM MAIN SWITCH

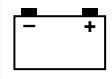

EB803020

**TROUBLESHOOTING**

**IF THE STARTER MOTOR FAILS TO OPERATE:**

**Procedure**

Check:

- |  |  |
|--|--|
| <ul style="list-style-type: none"> <li>1.Fuse</li> <li>2.Battery</li> <li>3.Starter motor</li> <li>4.Starter relay</li> <li>5.Main switch</li> <li>6.Engine stop switch</li> </ul> | <ul style="list-style-type: none"> <li>7.Start switch</li> <li>8.Neutral switch</li> <li>9.Clutch switch</li> <li>10.Wiring connection (the entire starting system)</li> </ul> |
|--|--|

**OTE:**

- Remove the following part(s) before troubleshooting:
  - 1)Seat
  - 2)Front fender
  - 3)Rear fender
  - 4)Exhaust pipe
- Use the following special tool(s) for troubleshooting.



**Pocket tester:**  
P/N. YU-03112, 90890-03112

EB802011

1.Fuse  
Refer to "CHECKING THE SWITCH".



NO CONTINUITY



Replace the fuse.

EB802012

2.Battery  
• Check the battery condition.  
Refer to "CHECKING THE BATTERY" in CHAPTER 3.

**Open-circuit voltage:**  
**12.8 V or more at 20 °C (68 °F)**



INCORRECT



- Clean the battery terminals.
- Recharge or replace the battery.

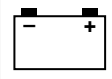

**3. Starter motor**

- Connect the battery positive terminal ① and starter motor cable ② using a jumper lead ③ \*.
- Check the operation of the starter motor.

\*

**⚠ WARNING**

- A wire that is used as a jumper lead must have the equivalent capacity or more as that of the battery lead, otherwise the jumper lead may burn.
- This check is likely to produce sparks, so be sure that no flammable gas or fluid is in the vicinity.

DOES NOT TURN



Repair or replace the starter motor.



**4. Starter relay**

- Remove the starter relay from the wire harness.
- Connect the pocket tester ( $\Omega \times 1$ ) and the battery (12 V) to the starter relay terminals.

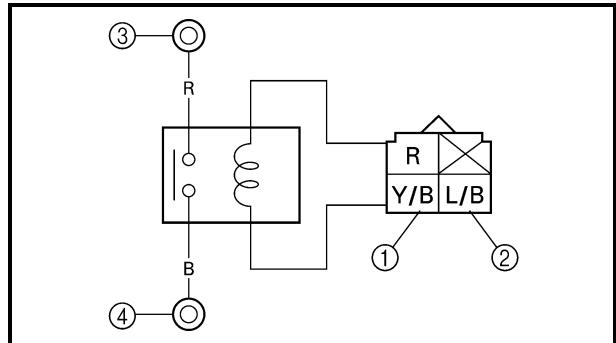

**Battery (+) terminal** → Yellow/Black terminal ①  
**Battery (-) terminal** → Blue/Black terminal ②

**Tester (+) lead** → Red terminal ③  
**Tester (-) lead** → Black terminal ④

- Check the starter relay for continuity.

NO CONTINUITY



Replace the starter relay.



**5. Main switch**

Refer to "CHECKING THE SWITCH".

INCORRECT



Replace the main switch.



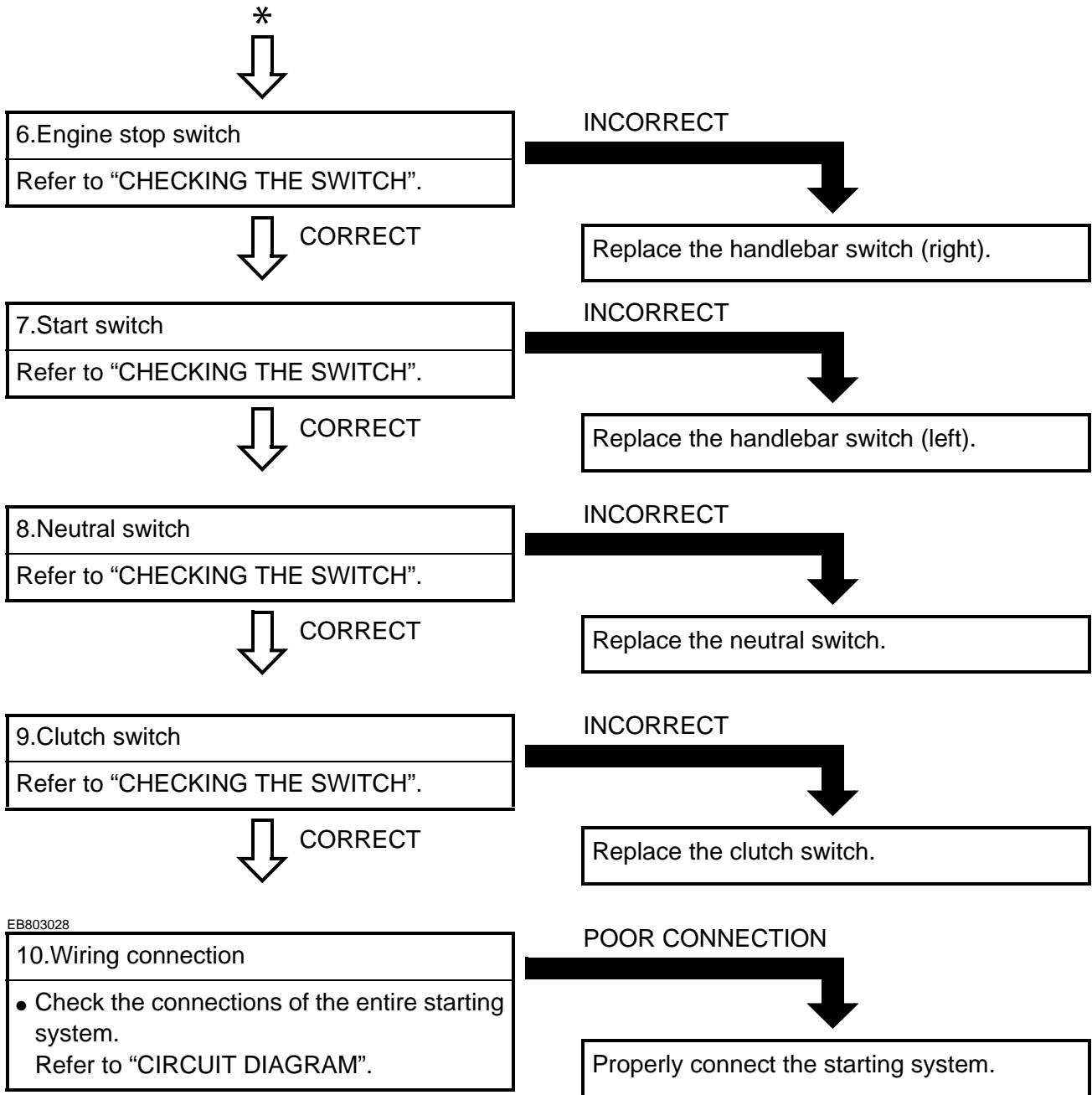
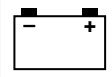



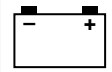

STARTER MOTOR

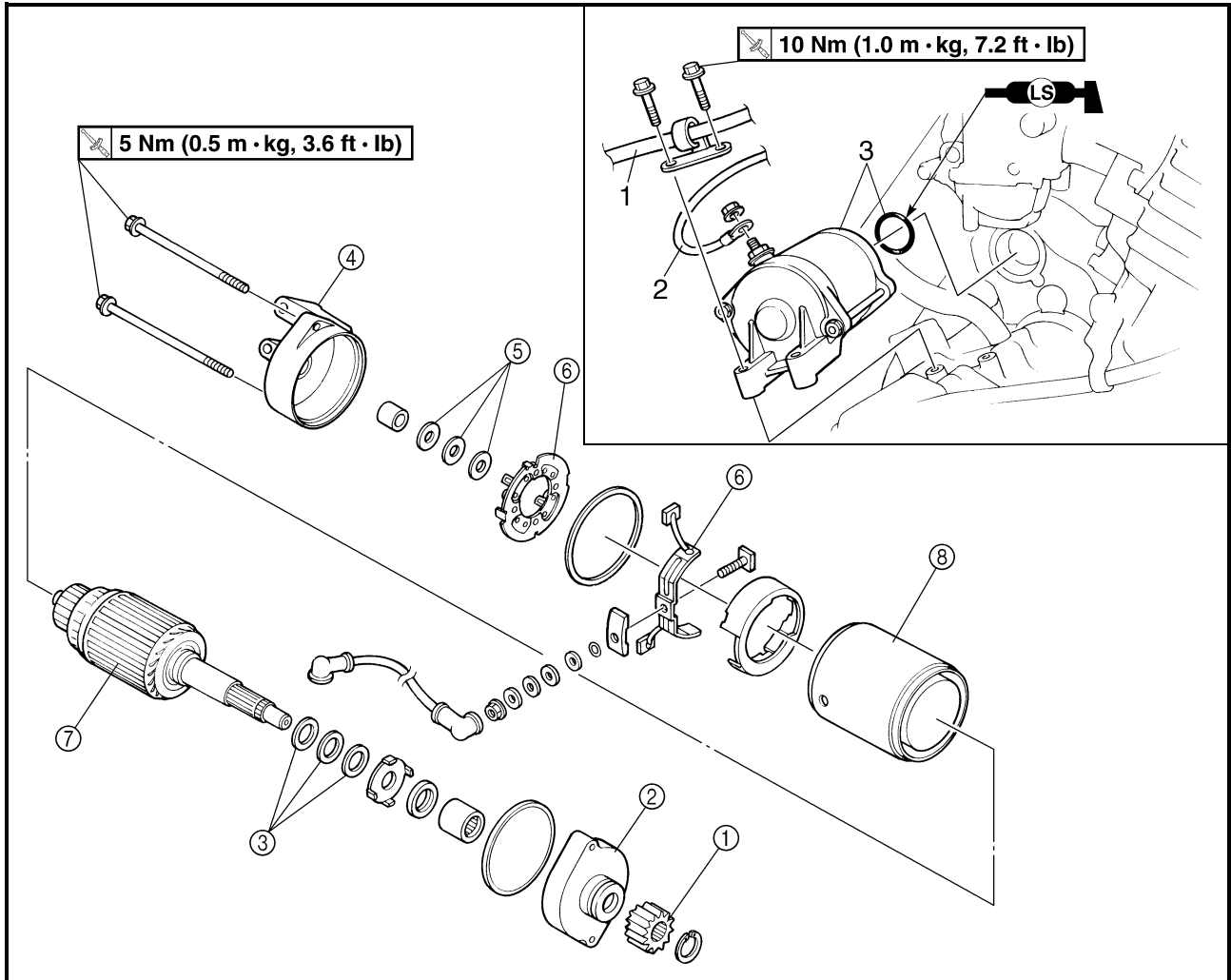

Order	Job name/Part name	Q'ty	Remarks
	<b>Removing the starter motor</b>		Remove the parts in the order below. Refer to "ENGINE REMOVAL".
1	Exhaust pipe		Disconnect.
2	Parking brake cable	1	
3	Starter motor lead	1	
3	Starter motor/O-ring	1/1	
	<b>Disassembling the starter motor</b>		Remove the parts in the order below.
①	Starter motor drive gear	1	
②	Bracket 1	1	
③	Washer kit		
④	Bracket 2	1	
⑤	Shims		
⑥	Brush seat 1/brush seat 2	1/1	Refer to "ASSEMBLING THE STARTER MOTOR".
⑦	Armature coil	1	
⑧	Yoke	1	
			For assembly, reverse the disassembly procedure.

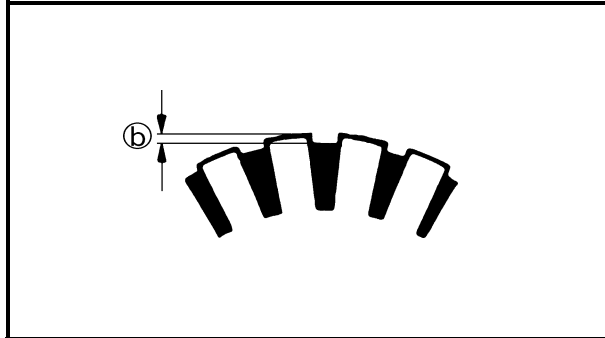
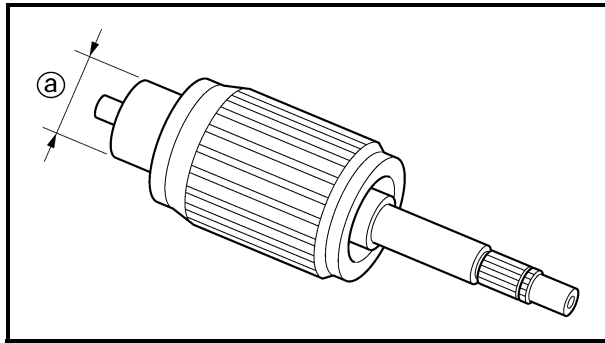
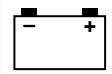

**CHECKING THE STARTER MOTOR**

1. Check:

- Commutator  
Dirty → Clean it with #600 grit sandpaper.

2. Measure:

- Commutator diameter Ⓐ  
Out of specification → Replace the starter motor.



**Outside diameter:**  
**28 mm (1.10 in)**  
**<Wear limit:>**  
**27 mm (1.06 in)**

3. Measure:

- Mica undercut Ⓑ  
Out of specification → Scrape the mica using a hacksaw blade.



**Mica undercut:**  
**0.7 mm (0.03 in)**

**OTE:**

Scrape the mica to the proper measurement using a hacksaw blade which has been grounded to fit the commutator.

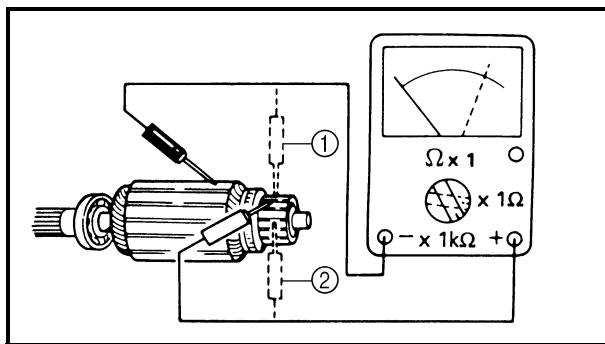

4. Check:

- Armature coil (insulation/continuity)  
Defects → Replace the starter motor.

\*\*\*\*\*

**Armature coil checking steps:**

- Connect the pocket tester for the continuity check ① and insulation check ②.
- Measure the armature resistances.



**Armature coil resistance:**  
**Continuity check ①:**  
**0.025 ~ 0.035 Ω at 20 °C (68 °F)**  
**Insulation check ②:**  
**More than 1 MΩ at 20 °C (68 °F)**

- If the resistance is incorrect, replace the starter motor.

\*\*\*\*\*

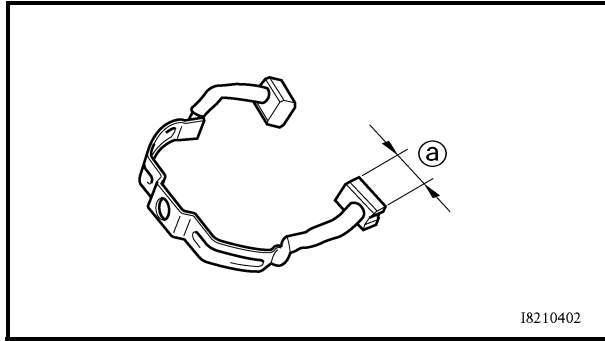
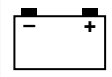

5.Measure:

- Brush length (a) (each)  
Out of specification → Replace the brush.



**Brush length:**  
12.5 mm (0.49 in)  
**<Wear limit:>**  
5 mm (0.20 in)

6.Measure:

- Brush spring force  
Fatigue/out of specification → Replace as a set.



**Brush spring force:**  
7.65 ~ 10.01 Nm  
(27.5 ~ 36.0 oz)

7.Check:

- Oil seal
- Bushing
- O-rings  
Wear/damage → Replace.

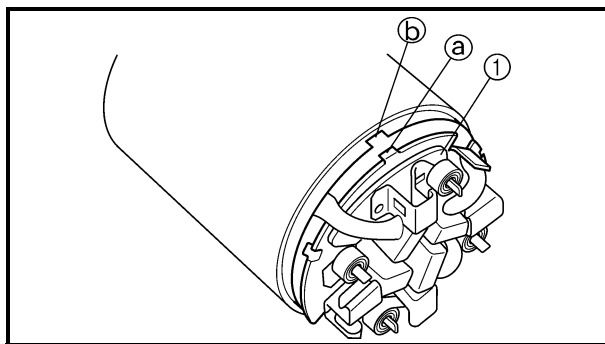

**ASSEMBLING THE STARTER MOTOR**

1.Install:

- Brush seat ①

**OTE:** \_\_\_\_\_

Align the projection (a) on the brush seat with the slot (b) on the housing.

\_\_\_\_\_

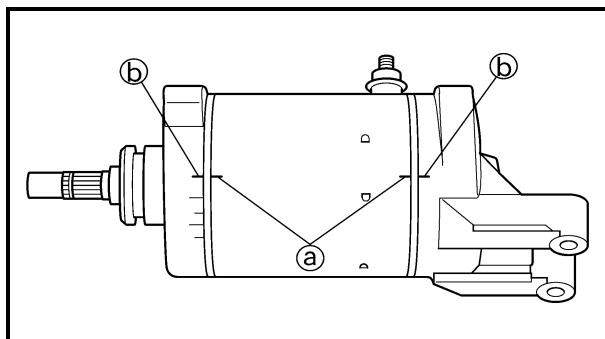

2.Install:

- Yoke
- Brackets

**OTE:** \_\_\_\_\_

Align the match marks (a) on the yoke with the match marks (b) on the brackets.

\_\_\_\_\_

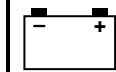

EB804000

CHARGING SYSTEM

CIRCUIT DIAGRAM

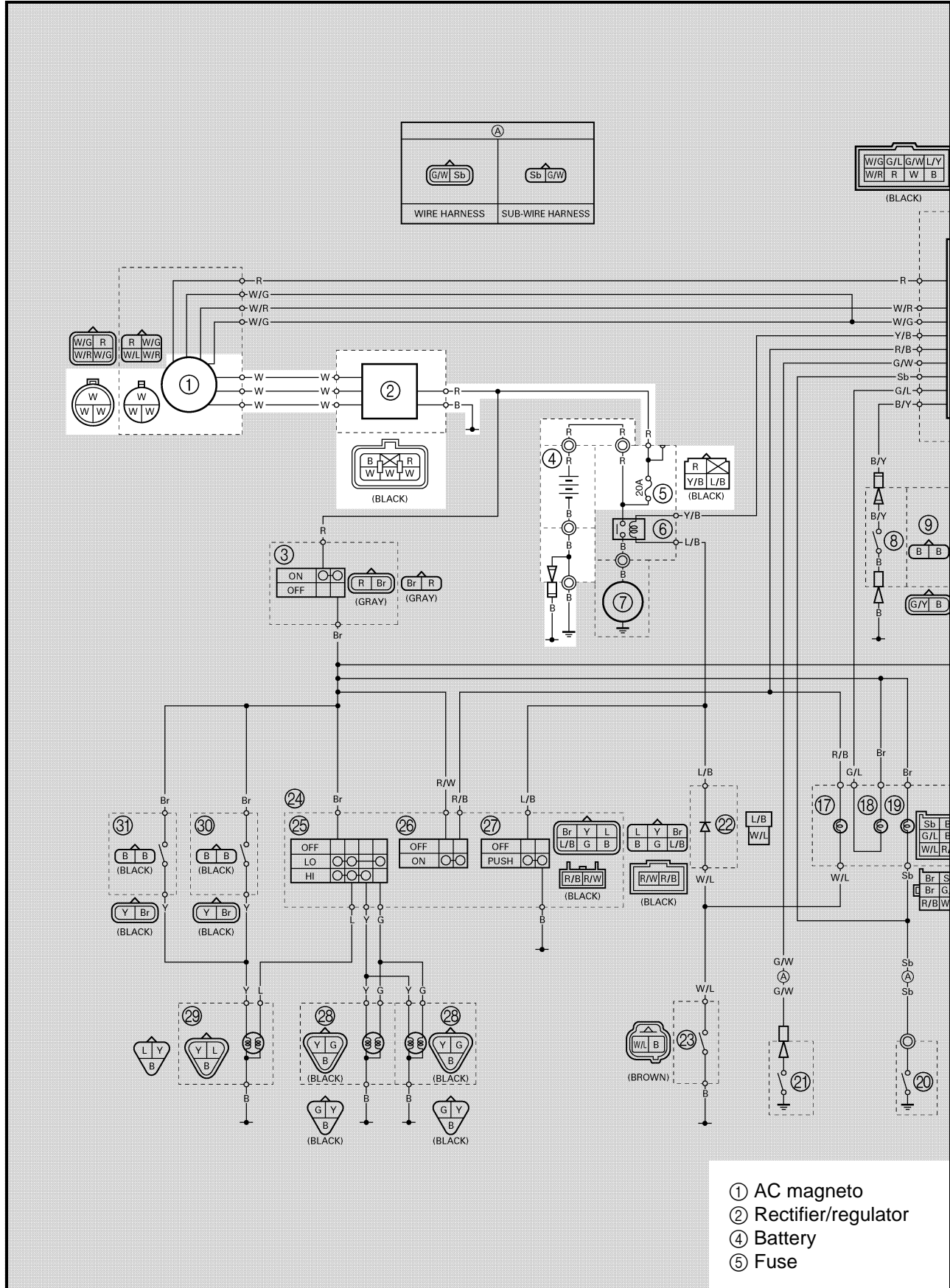

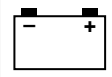

EB804010  
TROUBLESHOOTING

**IF THE BATTERY IS NOT CHARGED:**

**Procedure**

Check:

- 1.Fuse
- 2.Battery
- 3.Charging voltage
- 4.Charging coil resistance
- 5.Wiring connections  
(the entire charging system)

**OTE:**

- Remove the following part(s) before troubleshooting:
  - 1)Seat
- Use the following special tool(s) for troubleshooting.



**Pocket tester:**  
P/N. YU-03112, 90890-03112

EB802011

1.Fuse  
Refer to "CHECKING THE SWITCH".



EB802012

2.Battery

- Check the battery condition.  
Refer to "CHECKING THE BATTERY" in CHAPTER 3.

**Open-circuit voltage:**  
**12.8 V or more at 20 °C (68 °F)**



EB804011

3.Charging voltage

- Connect the tachometer to the spark plug lead.
- Connect the pocket tester (DC 20V) to the battery.

**Tester (+) lead → Battery (+) terminal**  
**Tester (-) lead → Battery (-) terminal**

NO CONTINUITY



Replace the fuse.

INCORRECT



- Clean the battery terminals.
- Recharge or replace the battery.

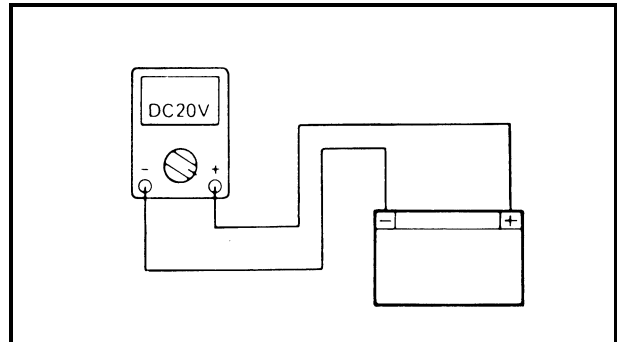

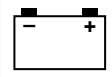

- Start the engine and accelerate to about 5,000 r/min.



**Charging voltage:**  
14 V at 5,000 r/min

OUT OF SPECIFICATION

MEETS SPECIFICATION

The charging circuit is not faulty.

EB804012

4. Charging coil resistance

- Disconnect the AC magneto coupler from the wire harness.
- Connect the pocket tester ( $\Omega \times 1$ ) to the charging coils.

Tester (+) lead → White terminal ①  
Tester (-) lead → White terminal ②

Tester (+) lead → White terminal ①  
Tester (-) lead → White terminal ③

Tester (+) lead → White terminal ②  
Tester (-) lead → White terminal ③

- Measure the stator coil resistance.



**Charging coil resistance:**  
0.43 ~ 0.65  $\Omega$  at 20 °C (68 °F)

MEETS SPECIFICATION

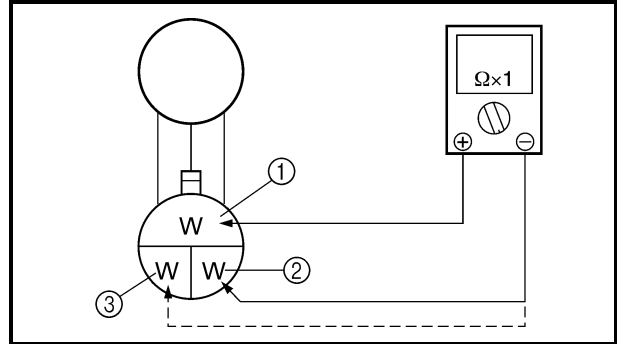

OUT OF SPECIFICATION

Replace the pickup coil/stator assembly.

EB804015

5. Wiring connections

- Check the connections of the entire charging system. Refer to "CIRCUIT DIAGRAM".

CORRECT

POOR CONNECTION

Properly connect the charging system.

Replace the rectifier/regulator.

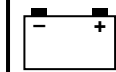

EB805000

LIGHTING SYSTEM

CIRCUIT DIAGRAM

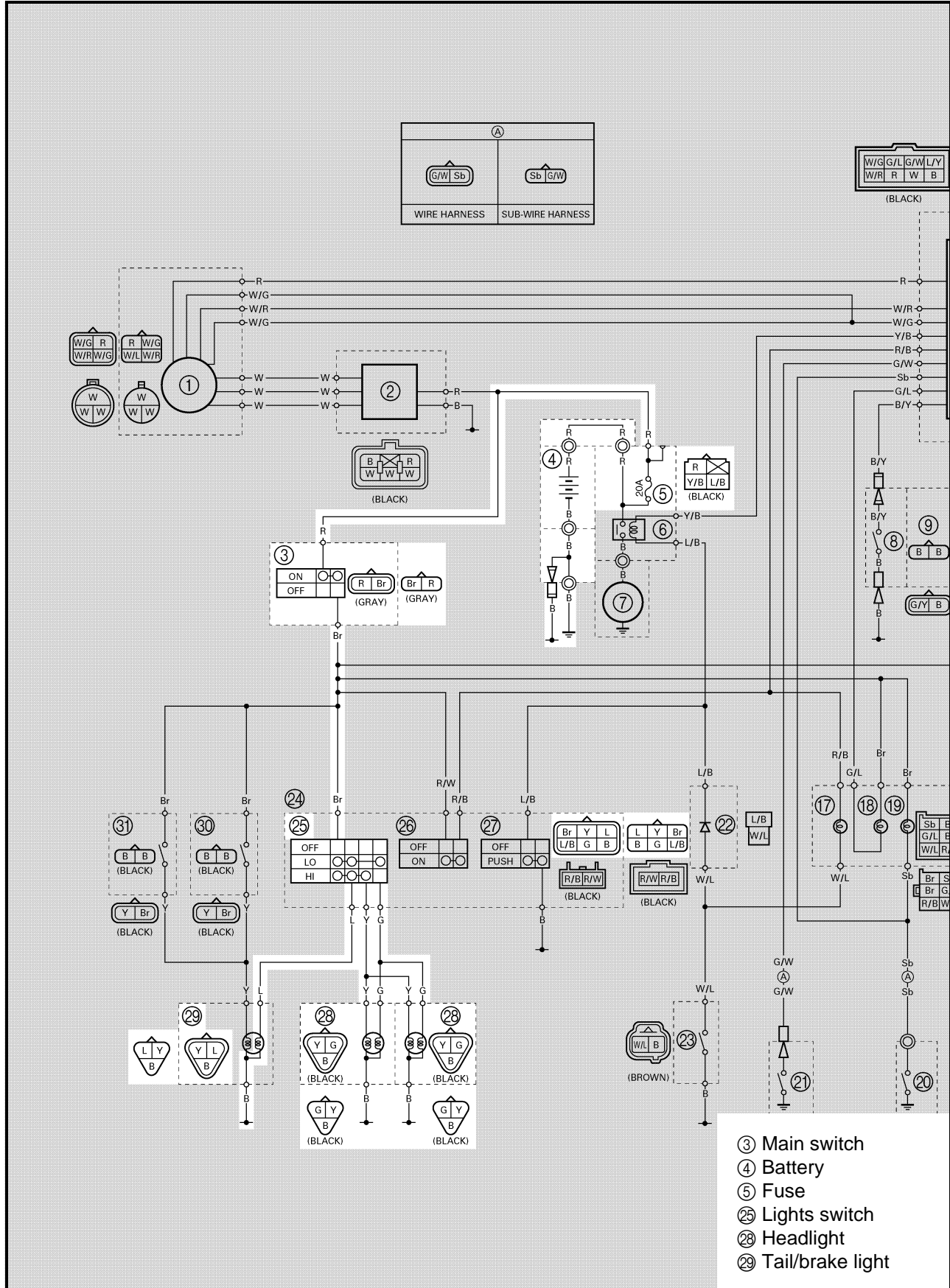

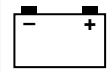

EB805010

**TROUBLESHOOTING**

**IF THE HEADLIGHT AND/OR TAIL/BRAKE LIGHT FAIL TO COME ON:**

**Procedure**

Check:

- |  |  |
|--|--|
| <ul style="list-style-type: none"> <li>1.Fuse</li> <li>2.Battery</li> <li>3.Main switch</li> </ul> | <ul style="list-style-type: none"> <li>4.Lights switch</li> <li>5.Wiring connections<br/>(the entire lighting system)</li> </ul> |
|--|--|

**OTE:**

- Remove the following part(s) before troubleshooting:
  - 1)Seat
  - 2)Front fender
- Use the following special tool(s) for troubleshooting.

	<p><b>Pocket tester:</b> P/N. YU-03112, 90890-03112</p>
--	---

EB802011

1.Fuse

---

Refer to "CHECKING THE SWITCH".



EB802012

2.Battery

- Check the battery condition.  
Refer to "CHECKING THE BATTERY" in CHAPTER 3.

---

**Open-circuit voltage:**  
**12.8 V or more at 20 °C (68 °F)**

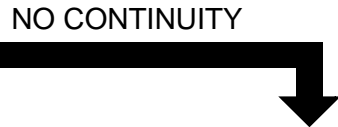

Replace the fuse.

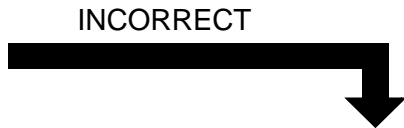

- Clean the battery terminals.
- Recharge or replace the battery.



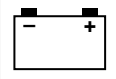

3.Main switch  
Refer to "CHECKING THE SWITCH".

INCORRECT



Replace the main switch.

↓ CORRECT

4.Lights switch  
Refer to "CHECKING THE SWITCH".

INCORRECT



Lights switch is faulty, replace the handlebar switch (left).

↓ CORRECT

EB805013  
5.Wiring connection  
• Check the connections of the entire lighting system.  
Refer to "WIRING DIAGRAM".

POOR CONNECTION



Properly connect the lighting system.

↓ CORRECT

Check the condition of each of the lighting system's circuits.  
Refer to "CHECKING THE LIGHTING SYSTEM".

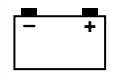

EB805020

**CHECKING THE LIGHTING SYSTEM**

1.If the headlights fail to come on:

1.Bulb and bulb socket

- Check the bulb and bulb socket for continuity.

NO CONTINUITY



Replace the bulb and/or bulb socket.

CONTINUITY



2.Voltage

- Connect the pocket tester (DC 20V) to the headlight couplers.

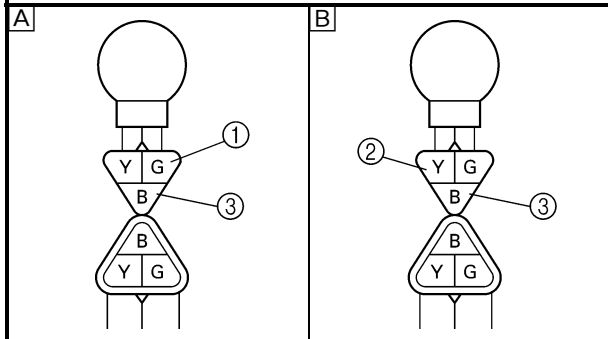

**Tester (+) lead** → **Green terminal ① or Yellow terminal ②**  
**Tester (-) lead** → **Black terminal ③**

**A** When the lights switch is on “LO”.  
**B** When the lights switch is on “HI”.

OUT OF SPECIFICATION



The wiring circuit from the main switch to the bulb socket connector is faulty, repair it.

MEETS SPECIFICATION



This circuit is not faulty.

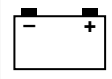

EB805021

2.If the tail/brake light fails to come on:

1.Bulb and bulb socket

- Check the bulb and bulb socket for continuity.

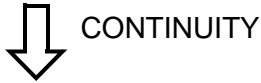

2.Voltage

- Connect the pocket tester (20 V) to the bulb socket coupler.

**Tester (+) lead → Blue terminal ①**  
**Tester (-) lead → Black terminal ②**

NO CONTINUITY



Replace the bulb and/or bulb socket.

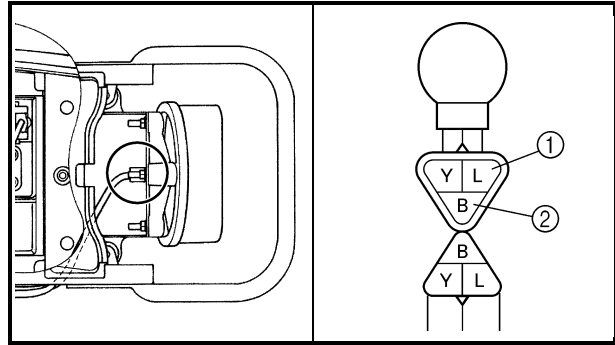

- Turn the main switch to “ON”.
- Turn the lights switch to “LO” or “HI”.
- Check the voltage (12 V) of the “Blue” lead on the bulb socket connector.



This circuit is not faulty.

OUT OF SPECIFICATION



The wiring circuit from the main switch to the bulb socket connector is faulty, repair it.

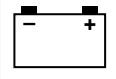

EB806000

**SIGNAL SYSTEM**  
**CIRCUIT DIAGRAM**

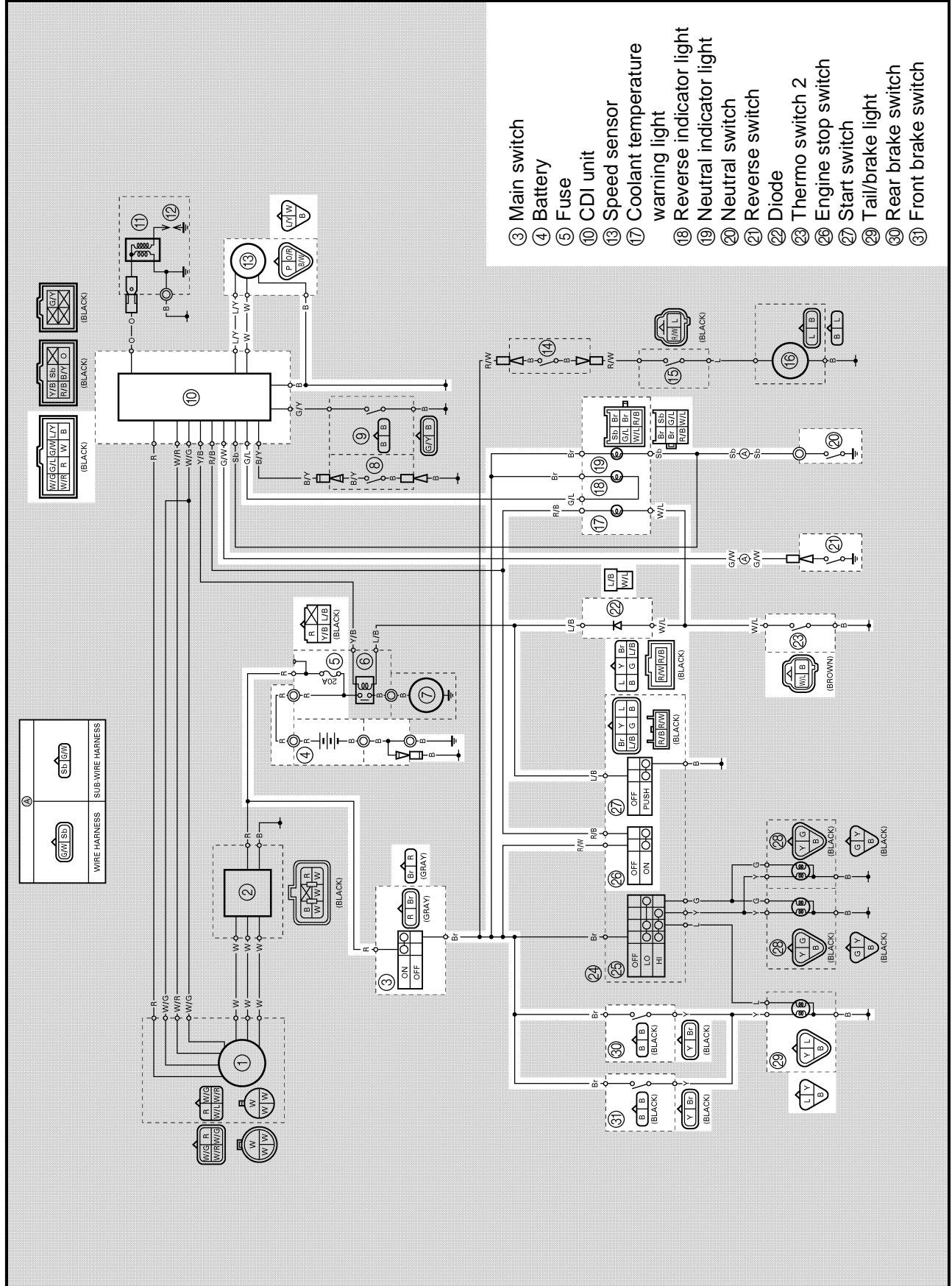

- ③ Main switch
- ④ Battery
- ⑤ Fuse
- ⑩ CDI unit
- ⑬ Speed sensor
- ⑰ Coolant temperature warning light
- ⑱ Reverse indicator light
- ⑲ Neutral indicator light
- ⑳ Neutral switch
- ㉑ Reverse switch
- ㉒ Diode
- ㉓ Thermo switch 2
- ㉔ Engine stop switch
- ㉕ Start switch
- ㉙ Tail/brake light
- ㉚ Rear brake switch
- ㉛ Front brake switch

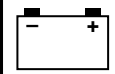

EB806010  
TROUBLESHOOTING

**IF THE TAIL/BRAKE LIGHT AND/OR INDICATOR LIGHT FAILS TO COME ON:**

**Procedure**

Check:

- 1.Fuse
- 2.Battery
- 3.Main switch
- 4.Wiring connections  
(the entire signal system)

**OTE:**

- Remove the following part(s) before troubleshooting:
  - 1)Seat
  - 2)Front fender
  - 3)Rear fender
- Use the following special tool(s) for troubleshooting.

	<p><b>Pocket tester:</b> P/N. YU-03112, 90890-03112</p>
--	---

EB802011

1.Fuse
Refer to "CHECKING THE SWITCH".



NO CONTINUITY



Replace the fuse.
-------------------

EB802012

2.Battery
<ul style="list-style-type: none"> <li>• Check the battery condition. Refer to "CHECKING THE BATTERY" in CHAPTER 3.</li> </ul>
<p><b>Open-circuit voltage:</b> <b>12.8 V or more at 20 °C (68 °F)</b></p>



INCORRECT



<ul style="list-style-type: none"> <li>• Clean the battery terminals.</li> <li>• Recharge or replace the battery.</li> </ul>
--

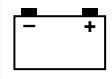

3.Main switch  
Refer to "CHECKING THE SWITCH".

INCORRECT



Replace the main switch.



CORRECT

EB806011

4.Wiring connections  
• Check the connections of the entire signal system.  
Refer to "CIRCUIT DIAGRAM".

POOR CONNECTION



Properly connect the signal system.



CORRECT

Check the condition of each of the signal system's circuits.  
Refer to "CHECKING THE SIGNAL SYSTEM".

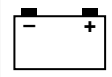

**CHECKING THE SIGNAL SYSTEM**

1.If the tail/brake light fails to come on:

1.Bulb and bulb socket  
 ● Check the bulb and bulb socket for continuity.



NO CONTINUITY



Replace the bulb and/or bulb socket.

2.Brake switches  
 Refer to “CHECKING THE SWITCH”.



NO CONTINUITY



Replace the brake switch.

3.Voltage  
 ● Connect the pocket tester (DC 20V) to the bulb socket coupler.  
**Tester (+) lead → Yellow terminal ①**  
**Tester (-) lead → Black terminal ②**

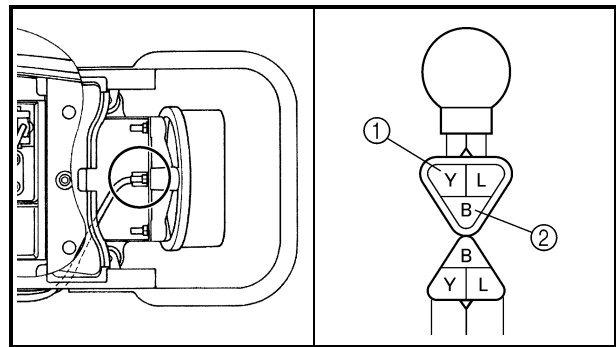

● Turn the main switch to “ON”.  
 ● Turn the lights switch to “LO” or “HI”.  
 ● Check the voltage (12 V) of the “Yellow” lead on the bulb socket connector.



OUT OF SPECIFICATION



The wiring circuit from the main switch to the bulb socket connector is faulty, repair it.

This circuit is not faulty.

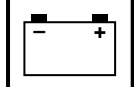

EB806024

2.If the neutral indicator light fails to come on:

1.Bulb and bulb socket  
 • Check the bulb and bulb socket for continuity.

CONTINUITY

NO CONTINUITY

Replace the bulb and/or bulb socket.

2.Neutral switch  
 Refer to "CHECKING THE SWITCH".

CONTINUITY

NO CONTINUITY

Replace the neutral switch.

3.Voltage  
 • Connect the pocket tester (DC 20V) to the bulb socket coupler.  
**Tester (+) lead → Brown terminal ①**  
**Tester (-) lead → Sky blue terminal ②**

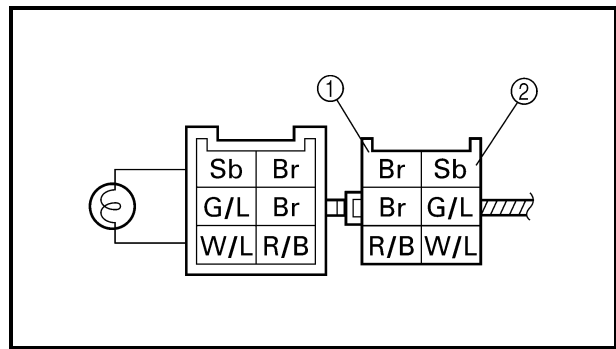

• Turn the main switch to "ON".  
 • Check the voltage (12 V).

MEETS SPECIFICATION

OUT OF SPECIFICATION

This circuit is not faulty.

The wiring circuit from the main switch to the bulb socket connector is faulty, repair it.



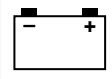

3.If the reverse indicator light fails to come on:

1.Bulb and bulb socket  
 • Check the bulb and bulb socket for continuity.

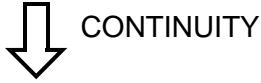

2.Reverse switch  
 Refer to "CHECKING THE SWITCH".



3.Voltage  
 • Connect the pocket tester (DC 20V) to the bulb socket coupler.  
**Tester (+) lead** → **Brown terminal** ①  
**Tester (-) lead** → **Green/Blue terminal** ②

NO CONTINUITY



Replace the bulb and/or bulb socket.

NO CONTINUITY



Replace the reverse switch.

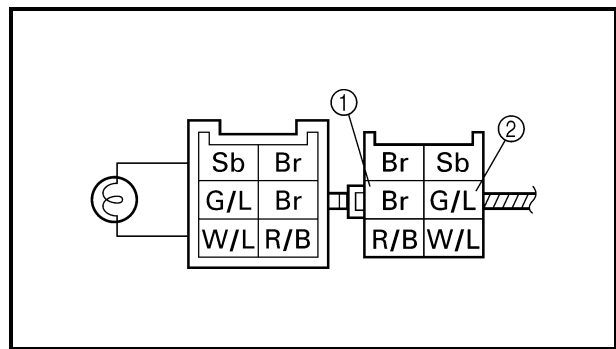

OUT OF SPECIFICATION



The wiring circuit from the main switch to the bulb socket connector is faulty, repair it.

• Turn the main switch to "ON".  
 • Check the voltage (12 V).



This circuit is not faulty.

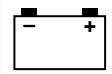

4.If the coolant temperature warning light does not come on when the start switch is pushed on, or if the coolant temperature warning light does not come on when the temperature is high (more than 117 ~ 123 °C (242.6 ~ 253.4 °F)):

1.Bulb and bulb socket

- Check the bulb and bulb socket for continuity.

CONTINUITY

NO CONTINUITY

Replace the bulb and/or bulb socket.

2.Thermo switch 2

- Remove the thermo switch from the thermostat housing.
- Connect the pocket tester ( $\Omega \times 1$ ) to the thermo switch ①.
- Immerse the thermo switch in coolant ②.
- Check the thermo switch for continuity. While heating the coolant use a thermometer ③ to record the temperatures.

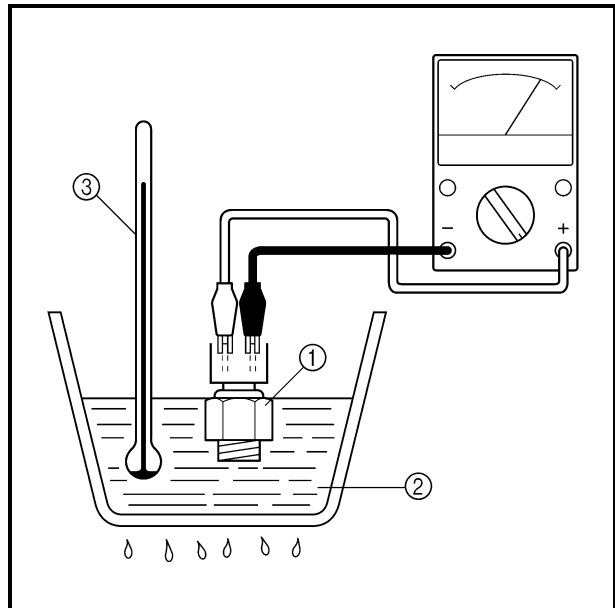

Test step	Water temperature	Good condition
	Thermo switch	
1	0 ~ 115 ± 3 °C (32 ~ 239 ± 5.4 °F)	×
2	More than 120 ± 3 °C (248 ± 5.4 °F)	○
3*	120 ± 3 to 115 ± 3 °C (248 ± 5.4 to 239 ± 5.4 °F)	○
4*	Less than 115 ± 3 °C (239 ± 5.4 °F)	×

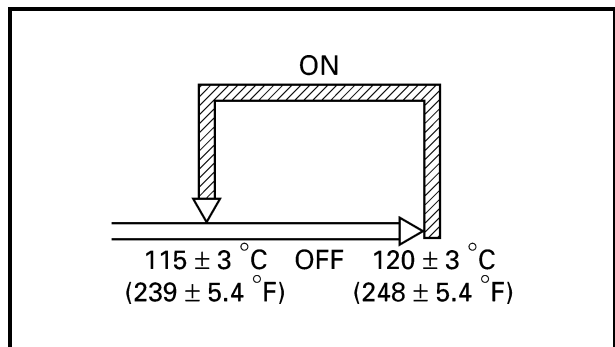

Tests 1 & 2; Heat-up tests  
 Tests 3\* & 4\*; Cool-down tests  
 ○ : Continuity      × : No continuity

**⚠ WARNING**

Handle the thermo switch with special care.  
 Never subject it to a strong shock or allow it to be dropped. Should it be dropped, it must be replaced.

 Thermo switch:  
 2.8 Nm (2.8 m • kg, 20 ft • lb)  
 Three bond sealock® #10

BAD CONDITION

Replace the thermo switch 2.

GOOD CONDITION

\*

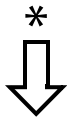
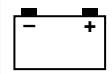

3.Voltage
<ul style="list-style-type: none"> <li>Connect the pocket tester (DC 20V) to the bulb socket coupler.</li> </ul>
<b>Tester (+) lead</b> → Red/Black terminal ① <b>Tester (-) lead</b> → White/Blue terminal ②

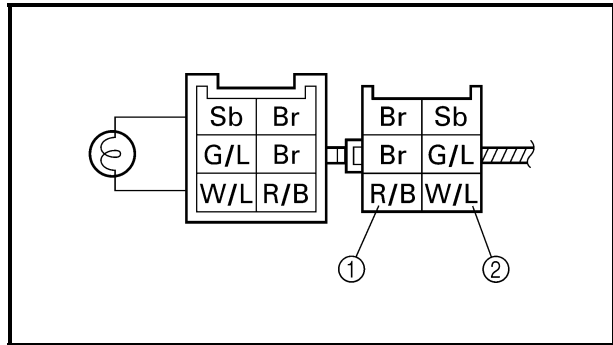

- Turn the main switch to "ON".
- Check the voltage (12 V).



OUT OF SPECIFICATION



The wiring circuit from the main switch to the bulb socket connector is faulty, repair it.

4.Diode	
<ul style="list-style-type: none"> <li>Remove the diode from the coupler.</li> <li>Connect the pocket tester (<math>\Omega \times 1</math>) to the diode terminals as shown.</li> <li>Check the diode for continuity as follows.</li> </ul>	
<b>Tester positive probe</b> → Blue/Black ① <b>Tester negative probe</b> → White/Blue ②	<b>Continuity</b>
<b>Tester positive probe</b> → White/Blue ② <b>Tester negative probe</b> → Blue/Black ①	<b>No continuity</b>

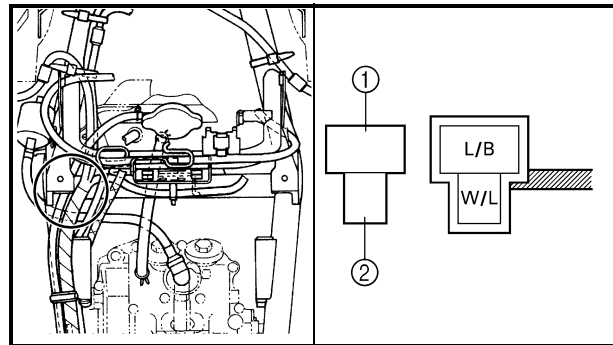

**OTE:** \_\_\_\_\_  
 When you switch the tester's positive and negative probes, the readings in the left chart will be reversed.  
 \_\_\_\_\_

INCORRECT



Replace the diode.

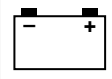

5.Start switch  
Refer to "CHECKING THE SWITCH".



CORRECT

This circuit is not faulty.

INCORRECT



Replace the handlebar switch (left).

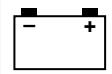

**COOLING SYSTEM  
CIRCUIT DIAGRAM**

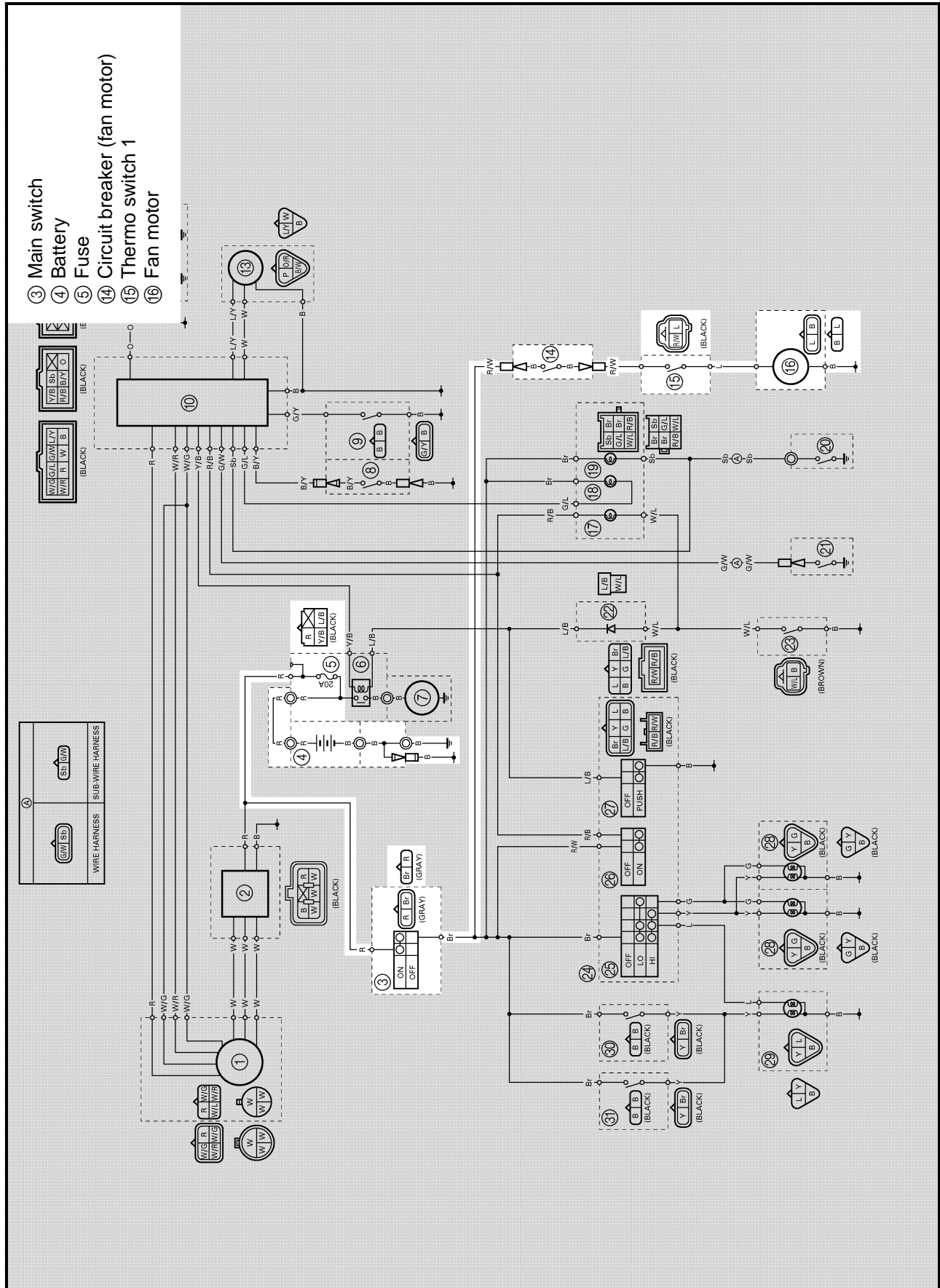

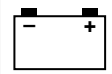

TROUBLESHOOTING

IF THE FAN MOTOR DOES NOT MOVE:

Procedure

Check:

- |  |  |
|--|--|
| <ul style="list-style-type: none"> <li>1.Fuse</li> <li>2.Battery</li> <li>3.Main switch</li> <li>4.Fan motor</li> <li>5.Circuit breaker (fan motor)</li> </ul> | <ul style="list-style-type: none"> <li>6.Thermo switch 1</li> <li>7.Wiring connection<br/>(the entire cooling system)</li> </ul> |
|--|--|

OTE:

- Remove the following part(s) before troubleshooting.
  - 1)Seat
  - 2)Front fender
- Use the following special tool(s) for troubleshooting.



**Pocket tester:**  
P/N. YU-03112, 90890-03112

EB802011

1.Fuse  
Refer to "CHECKING THE SWITCH".

NO CONTINUITY



CONTINUITY

Replace the fuse.

EB802012

2.Battery  
 • Check the battery condition.  
 Refer to "CHECKING THE BATTERY" in CHAPTER 3.  
**Open-circuit voltage:**  
**12.8 V or more at 20 °C (68 °F)**

INCORRECT



CORRECT

- Clean the battery terminals.
- Recharge or replace the battery.

3.Main switch  
Refer to "CHECKING THE SWITCH".

INCORRECT



CORRECT

Replace the main switch.

\*

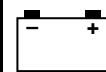

**4. Fan motor**

- Disconnect the fan motor coupler.
- Connect the battery (12 V) as shown.

**Battery (+) lead → Blue terminal ①**  
**Battery (-) lead → Black terminal ②**

- Check the operation of the fan motor.

DOES NOT TURN

Replace the fan motor.

↓ TURNS

**5. Circuit breaker (fan motor)**

- Remove the circuit breaker from the wire harness.
- Connect the pocket tester ( $\Omega \times 1$ ) to the circuit breaker.

**Circuit breaker resistance:  
Zero  $\Omega$  at 20 °C (68 °F)**

OUT OF SPECIFICATION

Replace the circuit breaker.

↓ MEETS SPECIFICATION

\*

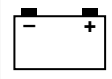

6. Thermo switch 1

- Remove the thermo switch from the radiator.
- Connect the pocket tester ( $\Omega \times 10$ ) to the thermo switch ①.
- Immerse the thermo switch in coolant ②.
- Check the thermo switch for continuity. While heating the coolant use a thermometer ③ to record the temperatures.

Test step	Water temperature	Good condition
	Thermo switch	
1	0 ~ $92 \pm 3 \text{ }^\circ\text{C}$ ( $32 \sim 197.6 \pm 5.4 \text{ }^\circ\text{F}$ )	×
2	More than $98 \pm 3 \text{ }^\circ\text{C}$ ( $208.4 \pm 5.4 \text{ }^\circ\text{F}$ )	○
3*	$98 \pm 3$ to $92 \pm 3 \text{ }^\circ\text{C}$ ( $208.4 \pm 5.4$ to $197.6 \pm 5.4 \text{ }^\circ\text{F}$ )	○
4*	Less than $92 \pm 3 \text{ }^\circ\text{C}$ ( $197.6 \pm 5.4 \text{ }^\circ\text{F}$ )	×

Tests 1 & 2; Heat-up tests  
 Tests 3\* & 4\*; Cool-down tests  
 ○: Continuity      ×: No continuity

**⚠ WARNING**  
 Handle the thermo switch with special care.  
 Never subject it to a strong shock or allow it to be dropped. Should it be dropped, it must be replaced.

 Thermo switch:  
 28 Nm (2.8 m • kg, 20 ft • lb)  
 Three bond sealock® #10

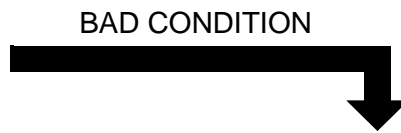
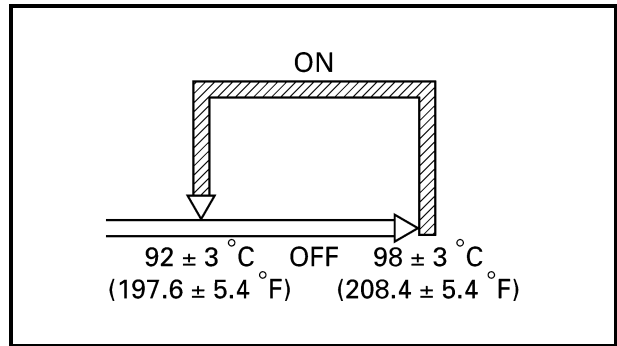
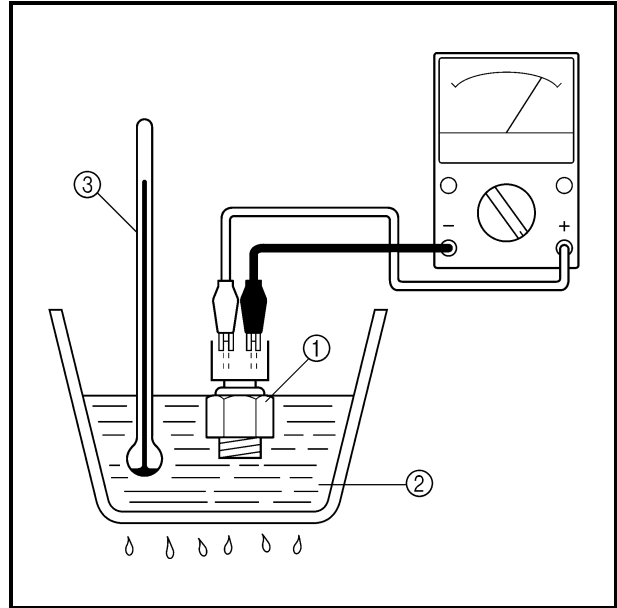

Replace the thermo switch 1.

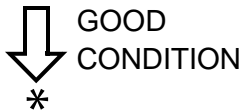



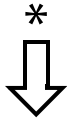
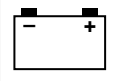

EB803028

7.Wiring connection

- Check the connections of the entire starting system.  
Refer to "CIRCUIT DIAGRAM".



CORRECT

This circuit is not faulty.

POOR CONNECTION



Properly connect the cooling system.

---

## TROUBLESHOOTING

**NOTE:**

The following troubleshooting does not cover all the possible causes of trouble. It should be helpful, however, as a guide to troubleshooting. Refer to the relative procedure in this manual for inspection, adjustment and replacement of parts.

---

### STARTING FAILURE/HARD STARTING

#### FUEL SYSTEM

**Fuel tank**

- Empty
- Clogged fuel filter
- Clogged fuel strainer
- Clogged fuel breather hose
- Deteriorated or contaminated fuel

**Fuel cock**

- Clogged fuel hose

**Carburetor**

- Deteriorated or contaminated fuel
- Clogged pilot jet
- Clogged pilot air passage
- Sucked-in air
- Deformed float
- Worn needle valve
- Improperly sealed valve seat
- Improperly adjusted fuel level
- Improperly set pilot jet
- Clogged starter jet
- Starter plunger malfunction

**Air filter**

- Clogged air filter element

#### ELECTRICAL SYSTEM

**Spark plug**

- Improper plug gap
- Worn electrodes
- Wire between terminals broken
- Improper heat range
- Faulty spark plug cap

**Ignition coil**

- Broken or shorted primary/secondary
- Faulty spark plug lead
- Broken body

**CDI system**

- Faulty CDI unit
- Faulty pickup coil
- Broken woodruff key

**Switches and wiring**

- Faulty main switch
- Faulty engine stop switch
- Broken or shorted wiring
- Faulty neutral switch
- Faulty start switch
- Faulty clutch switch

**Starter motor**

- Faulty starter motor
- Faulty starter relay
- Faulty starter circuit cut-off relay
- Faulty starter clutch

**Battery**

- Faulty battery

## **COMPRESSION SYSTEM**

### **Cylinder and cylinder head**

- Loose spark plug
- Loose cylinder head or cylinder
- Broken cylinder head gasket
- Broken cylinder gasket
- Worn, damaged or seized cylinder

### **Valve, camshaft and crankshaft**

- Improperly sealed valve
- Improperly contacted valve and valve seat
- Improper valve timing
- Broken valve spring
- Seized camshaft
- Seized crankshaft

### **Piston and piston rings**

- Improperly installed piston ring
- Worn, fatigued or broken piston ring
- Seized piston ring
- Seized or damaged piston

### **Crankcase and crankshaft**

- Improperly seated crankcase
- Seized crankshaft

### **Valve train**

- Improperly adjusted valve clearance
- Improperly adjusted valve timing

## **POOR IDLE SPEED PERFORMANCE**

### **POOR IDLE SPEED PERFORMANCE**

#### **Carburetor**

- Improperly returned starter plunger
- Loose pilot jet
- Clogged pilot jet
- Clogged pilot air jet
- Improperly adjusted idle speed (Throttle stop screw)
- Improper throttle cable play
- Flooded carburetor

#### **Electrical system**

- Faulty spark plug
- Faulty CDI unit
- Faulty pickup coil
- Faulty ignition coil

#### **Valve train**

- Improperly adjusted valve clearance

#### **Air filter**

- Clogged air filter element

## **POOR MEDIUM AND HIGH-SPEED PERFORMANCE**

### **POOR MEDIUM AND HIGH-SPEED PERFORMANCE**

Refer to "STARTING FAILURE/HARD STARTING" and "POOR IDLE SPEED PERFORMANCE-VALVE TRAIN".

#### **Carburetor**

- Improper jet needle clip position
- Improperly adjusted fuel level
- Clogged or loose main jet
- Deteriorated or contaminated fuel

#### **Air filter**

- Clogged air filter element



## **FAULTY GEAR SHIFTING**

### **HARD SHIFTING**

Refer to "CLUTCH DRAGGING".

### **SHIFT PEDAL DOES NOT MOVE**

#### **Shift shaft**

- Bent shift shaft

#### **Shift drum and shift fork**

- Groove jammed with impurities
- Seized shift fork
- Bent shift fork guide bar

#### **Transmission**

- Seized transmission gear
- Jammed impurities
- Incorrectly assembled transmission

#### **Shift guide**

- Broken shift guide

### **JUMP-OUT GEAR**

#### **Shift shaft**

- Improperly adjusted shift lever position
- Improperly returned stopper lever

#### **Shift fork**

- Worn shift fork

#### **Shift drum**

- Improper thrust play
- Worn shift drum groove

#### **Transmission**

- Worn gear dog

## **CLUTCH SLIPPING/Dragging**

### **CLUTCH SLIPPING**

#### **Clutch**

- Loose clutch spring
- Fatigued clutch spring
- Worn friction plate
- Worn clutch plate
- Incorrectly assembled clutch

#### **Engine oil**

- Low oil level
- Improper quality (low viscosity)
- Deterioration

### **CLUTCH DRAGGING**

#### **Clutch**

- Warped pressure plate
- Unevenly tensioned clutch springs
- Match marks not aligned
- Loose clutch boss nut
- Burnt primary driven gear bushing
- Bent clutch plate
- Swollen friction plate
- Broken clutch boss

#### **Transmission oil**

- High oil level
- Improper quality (high viscosity)
- Deterioration

## **OVERHEATING**

### **OVERHEATING**

#### **Ignition system**

- Improper spark plug gap
- Improper spark plug heat range
- Faulty CDI unit

#### **Fuel system**

- Improper carburetor main jet  
(improper setting)
- Improper fuel level
- Clogged air filter element

#### **Compression system**

- Heavy carbon deposit

#### **Engine oil**

- Improper oil level
- Improper oil viscosity
- Inferior oil quality

#### **Brake**

- Brake drag

#### **Cooling system**

- Low coolant level
- Clogged or damaged radiator
- Damaged or faulty water pump
- Thermostat stays closed

## **OVER COOLING**

### **COOLING SYSTEM**

#### **Thermostat**

- Thermostat stays open

## **FAULTY BRAKE**

### **POOR BRAKING EFFECT**

#### **Disc brake**

- Worn brake pads
- Worn disc
- Air in brake fluid
- Leaking brake fluid
- Faulty master cylinder kit cup
- Faulty caliper kit seal
- Loose union bolt
- Broken brake hose and pipe
- Oily or greasy disc/brake pads
- Improper brake fluid level

## **SHOCK ABSORBER MALFUNCTION**

### **MALFUNCTION**

- Bent or damaged damper rod
- Damaged oil seal lip
- Fatigued shock absorber spring

## **UNSTABLE HANDLING**

### **UNSTABLE HANDLING**

#### **Handlebar**

- Improperly installed or bent

#### **Steering**

- Incorrect toe-in
- Bent steering stem
- Improperly installed steering stem
- Damaged bearing or bearing race
- Bent tie rods
- Deformed steering knuckles

#### **Tires**

- Uneven tire pressures on both sides
- Incorrect tire pressure
- Uneven tire wear

#### **Wheels**

- Deformed wheel
- Loose bearing
- Bent or loose wheel axle
- Excessive wheel runout

#### **Frame**

- Bent
- Damaged frame

#### **Swingarm**

- Worn bearing or bushing
- Bent or damaged

## **LIGHTING SYSTEM**

### **HEADLIGHT DARK**

- Improper bulb
- Too many electric accessories
- Hard charging (broken charging coil and/or faulty rectifier/regulator)
- Incorrect connection
- Improperly grounded
- Poor contacts (main or lights switch)
- Bulb life expired

### **BULB BURNT OUT**

- Improper bulb
- Faulty battery
- Faulty rectifier/regulator
- Improperly grounded
- Faulty main and/or lights switch
- Bulb life expired



YAMAHA MOTOR CO., LTD.  
2500 SHINGAI IWATA SHIZUOKA JAPAN

PRINTED IN U.S.A.

# YFM660R WIRING DIAGRAM

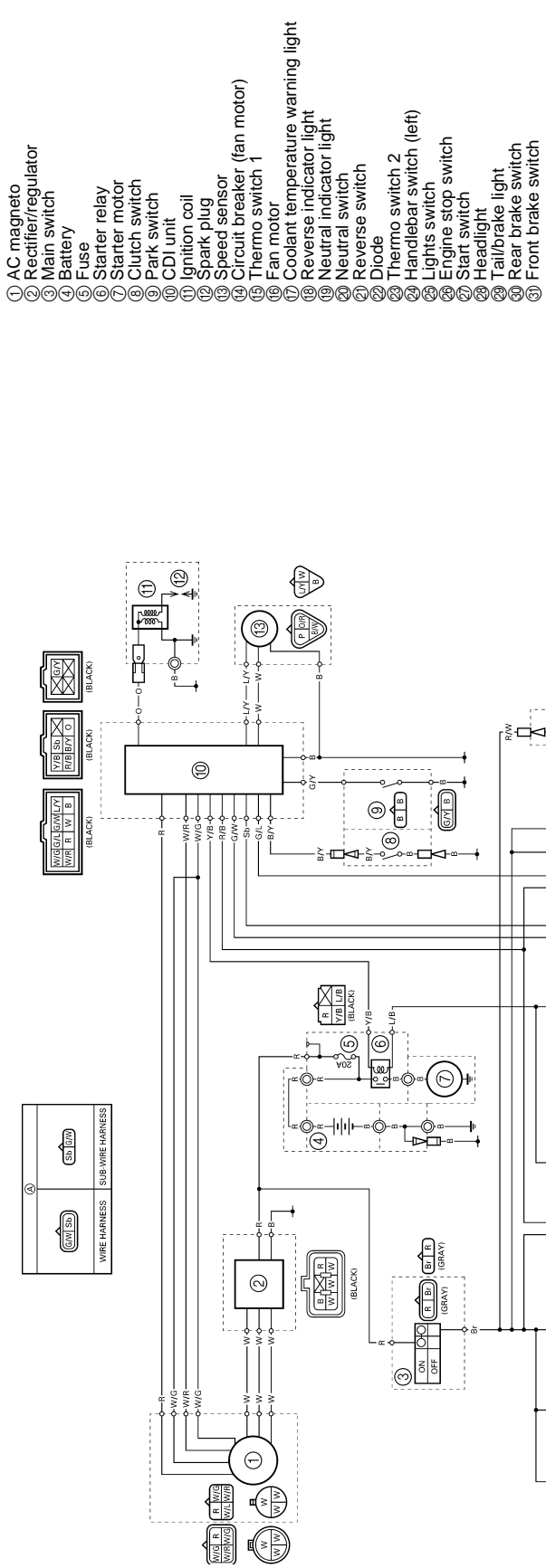

**COLOR CODE**

B	Black
Br	Brown
G	Green
L	Blue
O	Orange
P	Pink
R	Red
Sb	Sky blue

W	White
Y	Yellow
B/W	Black/White
B/Y	Black/Yellow
Br/L	Brown/Blue
Br/R	Brown/Red
Br/W	Brown/White
G/L	Green/Blue

G/W	Green/White
G/Y	Green/Yellow
L/B	Blue/Black
L/G	Blue/Green
L/R	Blue/Red
L/W	Blue/White
L/Y	Blue/Yellow
O/R	Orange/Red

R/B	Red/Black
R/W	Red/White
R/Y	Red/Yellow
W/B	White/Black
W/G	White/Green
W/L	White/Blue
W/R	White/Red
Y/B	Yellow/Black