



The partner you can trust

Standard Motor Corp

Sports ATVs/Quads

Oil cooled **250cc**

Extension 01 Water cooled **250/300cc**

CVT **250/300cc**

SERVICE MANUAL

By Powerpoint

Standard Motor Corporation
正鶴工業股份有限公司

INTRODUCTION

- Update note: for 250/300 Water Cooled(Gear/CVT) Engine
- Update: Jan. 17, 2007

The update note of work-shop (or service) manual is mainly for Standard Motor Corp. Area importers and their net-work dealers & service stations to fulfill the necessary maintenance and repairs information.

1. Due to continuous launch of new models, information in this manual may be subject to change without notice. For any further information regarding this manual or the products, please contact the Territorial Distributor or Area Importer.
2. All details of this manual are based on the latest product information available at the time of approval for printing. Maker reserves the right to make changes at any time without notice and without incurring any obligation.
3. This manual has been specially prepared to provide the necessary information for the Area importer, dealers, and their qualified mechanics of proper maintenance and repair details.
4. This manual covers the 250/300 water cooled engine in Gear transmission (250L/300L) and CVT transmission (250LV/300LV) items that user has to find out what details belong to. The existing oil or air cooled engine will be showing on old version of service manual.

By: Sales and Service Department of Standard Motor Corp.

For Area Importer and Territorial Distributor: Maker (Standard Motor Corp.) only confirms the products and all necessary usage information on this text. If wishes to re-make on their own language manual, Importer should get the written confirmation of authorization from maker to ensure the translation text own maker right. Otherwise, maker will pay no any responsibility on any of claim of incorrect way of usage.

* All rights reserved. No part of this manual may be reproduced or unauthorized use in any form or by any means, without prior permission of the Maker, Standard Motor Corp. Taipei, Taiwan R.O.C.
<http://www.standardmoto.com>

Update IMPORTANT NOTICE

- NOTE: this is update note – the rest of detail parts refer to last service manual.

The ATVs is designed and built for OFF-ROAD use and single rider only. It is illegal and risky to maneuver this ATV on any public street, road or highway. Be sure to check your local riding laws and regulations before riding this ATV.

The ATVs with E/e or other approval ON-ROAD use has to match the local legal riding laws and regulation. For any further information regarding on “ON Road” matter, please contact the Area Importer or Territorial Distributor. * it may have lots of different points in ON Road rule i.e. tire pressure, ..., where the Territorial Importer or Distributor will provide all necessary and correct information to match each area regulation.

To operate ATV is different from other vehicles such as motorcycles, scooters, and cars. It can be hazardous to operate. If you do not follow the instructions, a collision or rollover can be occurred that severe injury or death may result. Never use an ATV without exact training or instruction.

The ATVs max. power, max. torque, top speed, are for the professional rider reference. The ATV is designed for recreational use by skilled operators only, which the sports ATV operation differs from other vehicles such as other types of ATV, scooters, or motorcycles. Riding the ATV requires special skills acquired through practice. It is essential to familiarize the operation to achieve the skills necessary to enjoy riding safely. Keep ATV at slow speeds during first operation. Do not attempt to operate at maximum speeds until you are totally familiar with the ATV operation.

Gear water cooled engine = 250L or 300L; CVT water cooled engine = 250LV or 300LV

Always follow the shift-introduction whenever engage the neutral or reverse gear. During engaging F-R (gear model) or F-N-R (CVT model) operation, be sure stop vehicle completely and do not make any acceleration. Maker will pay no any responsibility whenever the mistake of user on F-R or F-N-R shifting operation

Be sure to check the coolant level on reserve tank (should between maximum and minimum mark). Always keeps the coolant level between Max. and Min. mark (coolant reservoir), replace if it necessary. Replace all new coolant every 16-20 months! Only use the distilled water to mix coolant. (standard concentration 50%)

CAUTION: only check coolant level when engine is cold. Never open the radiator cap during the engine is warm or running.



The partner you can trust

CONTENTS

PART 1. GENERAL INFORMATION

- 1-01. Service Precautions
- 1-02. Briefing Service Information

PART 2. SPECIFICATION

- 2-01. General Specification
- 2-02. Location & Cable Routing
- 2-03. Torque Value
- 2-04. Special Tools – OPTION (reference)

PART 3. PERIODIC MAINTENANCE AND ADJUSTMENT

- 3-01. Periodic maintenance table

PART 4. GEAR ENGINE DETAILS

- 4-01. Fuel System and Carburetion
- 4-02. Lubrication System
- 4-03. Engine Removal/Installation
- 4-04. Cylinder Head/Valve
- 4-05. Cylinder/Piston
- 4-06. Starter/Generator/L. Crankcase/Start Clutch/Camshaft
- 4-07. Clutch/Gear Shift Mechanism
- 4-08. Crankcase/Crankshaft/Transmission/Starter Spindle
- 4-09. Water Cooled System
 - / NOTE: service information
 - / NOTE: problems shooting <Q-A>
 - / 01. Radiator cap inspection
 - / 02. Radiator inspection
 - / 03. Radiator removal
 - / 04. Radiator disassembly
 - / 05. Thermostatic switch
 - / 06. Radiator assembly and installation
 - / 07. Water pump mechanical seal inspection
 - / 08. Water pump/impeller removal
 - / 09. Water pump shaft removal
 - / 10. Mechanical seal replacement
 - / 11. Water pump shaft installation
 - / 12. Water pump/impeller installation
 - / 13. Thermo-sensor removal and inspection
 - / 14. Thermo-sensor installation
 - / 15. Thermostat removal
 - / 16. Thermostat inspection
 - / 17. Thermostat installation

PART 4-a. CVT ENGINE DETAILS

4-01. CVT Fuel System and Carburetion

- / NOTE: Service information
- / NOTE: Problems shooting <Q-A>
- / 01. Throttle valve disassembly
- / 02. Throttle valve assembly
- / 03. Carburetor removal
- / 04. Carburetor disassembly
- / 05. Carburetor cleaning and float valve inspection
- / 06. Fuel reservoir o-ring inspection
- / 07. Fuel float valve and reservoir assembly
- / 08. Float level inspection
- / 09. Carburetor installation

4-02. CVT Lubrication System

- / NOTE: Service Information
- / NOTE: Problems shooting <Q-A>
- / 01. Oil pump removal
- / 02. Oil pump disassembly and inspection
- / 03. Oil pump assembly
- / 04. Installation

4-03. CVT Engine Removal/Installation

- / NOTE: Service information
- / 01. Engine removal
- / 02. Engine installation

4-04. CVT Cylinder Head/Valves

- / NOTE: Service information
- / NOTE: Problems shooting <Q-A>
- / 01. Cylinder head cover removal and installation
- / 02. Camshaft holder removal
- / 03. Camshaft holder disassembly
- / 04. Camshaft holder inspection
- / 05. Camshaft holder assembly and inspection
- / 06. Camshaft installation
- / 07. Cylinder removal
- / 08. Cylinder head disassembly
- / 09. Valve/valve guide inspection
- / 10. Cylinder head inspection
- / 11. Valve spring inspection
- / 12. Assembly
- / 13. Installation

4-05. CVT Cylinder/Piston

- / NOTE: Service information
- / NOTE: Problems shooting <Q-A>
- / 01. Cylinder/piston removal
- / 02. Inspection
- / 03. Cylinder inspection
- / 04. Cylinder inspection
- / 05. Piston ring installation
- / 06. Piston installation
- / 07. Cylinder installation

4-06. CVT Clutch/Gearshift Linkage

- / NOTE: Service information
- / NOTE: Problems shooting <Q-A>
- / 01. Left crankcase cover removal
- / 02. Inspection and installation
- / 03. Drive pulley removal
- / 04. Drive pulley disassembly and inspection
- / 05. Drive pulley assembly
- / 06. Installation
- / 07. Clutch driven pulley removal
- / 08. Drive belt inspection
- / 09. Clutch outer inspection
- / 10. Clutch/Drive pulley disassembly
- / 11. Inspection
- / 12. Driven pulley face bearing replacement
- / 13. Clutch disassembly
- / 14. Clutch driven pulley assembly
- / 15. Installation

4-07. CVT Final Reduction and Transmission

- / NOTE: service information
- / NOTE: problems shooting <Q-A>
- / 01. Transmission case cover removal
- / 02. Transmission case cover disassembly
- / 03. Assembly
- / 04. Transmission removal
- / 05. Main axles disassembly
- / 06. Primary drive axles removal
- / 07. Installation

4-08. CVT Crankcase/Crankshaft/Balance Shaft

- / NOTE: service information
- / NOTE: problems shooting <Q-A>
- / 01. Crankcase/Crankshaft/Balance Shaft removal
- / 02. Crankshaft inspection
- / 03. Crankcase/balancer installation

4-09. CVT Water Cooling System

- / NOTE: service information
- / NOTE: problems shooting <Q-A>
- / 01. Radiator cap inspection
- / 02. Radiator inspection
- / 03. Radiator removal
- / 04. Radiator disassembly
- / 05. Thermostatic switch
- / 06. Radiator assembly and installation
- / 07. Water pump mechanical seal inspection
- / 08. Water pump/impeller removal
- / 09. Water pump shaft removal
- / 10. Mechanical seal replacement
- / 11. Water pump shaft installation
- / 12. Water pump/impeller installation
- / 13. Thermo-sensor removal and inspection
- / 14. Thermo-sensor installation
- / 15. Thermostat removal
- / 16. Thermostat inspection
- / 17. Thermostat installation



PART 1. GENERAL INFORMATION

1-1. Service Precautions

01. Be sure to use the new gaskets, o-rings, ring clamps, cotter pins, .. during the re-assembly or any service.(Fig. 1-01)
02. When tightening bolts, screws, or nuts, should start with large diameter bolts to smaller ones. Be tighten to the specified torque diagonally.(Fig. 1-02)
03. Only use genuine parts and lubricants as Maker's suggestion (Fig. 1-03)
04. On servicing vehicle, be sure to use the special or common tools(Fig. 1-04)
05. After disassembly, be cleaned all the removed parts. Lubricate sliding surfaces with engine oil on engine parts before reassembly (Fig. 1-05).
06. Apply designated greases and lubricants to the specified lubrication points.(Fig. 1-06)
07. After reassembly, check all parts for proper tightening and operation.(Fig. 1-07)
08. Disconnect battery negative (-) terminal before operation.(Fig. 1-08)
09. When connecting the battery, the positive (+) terminal should be connected first. After connection, apply grease to battery terminals. The terminal caps shall be installed securely. (Fig. 1-09)
10. If the fuse is burned out, only replace the new fuse with the specified capacity.(Fig. 1-10)
11. When using a spanner or other tools, make sure not to damage the vehicle's surface.
12. After service operation, check all connecting points, fasteners and lines for proper connection and installation.



1-2. Briefing Service Information

<! WARNING> To avoid the engine running during repair or service, the exhaust smoke contains poisonous carbon monoxide gas which may cause serious injury or death.

SOLUTION:

1. Never run the engine in a close area.
2. If need to run the engine, be sure the working area is well ventilated and do not allow any flames or spark in working area.

1-2-1. Identification numbers (Fig. 1-11, 1-12)

- / 01. The vehicle identification number (VIN) marks on the frame.
- / 02. Engine number is marked on the engine.

1-2-2. Gear Engine 250L/300L: details refer to Part 4 gear engine

- / 01. Cylinder compression : 10.2 +/- 0.1 kg/cm²
- / 02. Idle speed : 1,500 +/- 100 rpm
- / 03. Valve clearance : IN = 0.05mm EX = 0.05mm
- / 04. Ignition timing : 15 degree/1,500 rpm; or 20 degree/1,500 rpm
- / 05. Engine oil (4-stroke) : SAE 15W40 disassembly = 1.9L; change = 1.7L
- / 06. Reverse gear oil : SAE # 40 disassembly = 1.4L; change = 1.2L
- / 07. Radiator : 1.4-1.45L coolant (standard concentration 50%)
- / 08. Reserve tank cooler : 300cc +/- 20cc coolant (standard concentration 50%)

1-2-3. CVT Engine 250LV/300LV: details refer to Part 4-a CVT engine

- / 01. Cylinder compression : 250LV = 10.3 and 300LV = 10.4 +/- 0.1 kg/cm²
- / 02. Idle speed : 1,500 +/- 100 rpm
- / 03. Valve clearance : IN = 0.1mm EX = 0.1mm
- / 04. Ignition timing : 250LV = 5 and 300LV = 5 degree/2,000 rpm
- / 05. Engine oil (4-stroke) : SAE 15W40 disassembly = 1.6L; change = 1.4L
- / 06. Transmission gear oil : SAE # 90 disassembly = 0.4L; change = 0.3L
- / 07. Radiator : 1.1-1.2L coolant (standard concentration 50%)
- / 08. Reserve tank cooler : 300cc +/- 20cc coolant (standard concentration 50%)



PART 2. SPECIFICATION

2-1-1. 5 Speeds Gear Engine (300L/250L)

Dimension : 1734mm/1120mm/1065mm
 Seat height : 858mm
 Wheel base : 1200mm
 Weight : 300L = 197kg; 250L = 195kg

Engine : 4 Stroke Liquid Cooled
 Cylinder : Twin – Vertical (Forward Inclined)
 Bore * Stroke : 300L = twin 53 x 57mm; 250L = twin 53 x 53mm
 Displacement : 300L = 270cc; 250L = 234cc
 Carburetor : Mikuni VM 26-672 or Walbro PZ 30B12

Spark : NGK CR7HSA x 2
 Starting : Electrical starter
 Ignition : C.D.I.
 Generator : ACG Fly Wheel Magneto
 Battery : YUASA YTX 9A-BS or GTX9L-BS

Engine Oil : 4 Stroke SAE 15W40; API SG/CD
 Engine Oil : at change (1.7L) at disassembly (1.9L)
 Air-Filter : Wet type element
 Reverse Gear Oil : SAE # 40; at change (1.2L) at disassembly (1.4L)

Transmission (F-R) : F/R shift selector function with Brake and R speed limited 15km/hr.

Fuel : Unleaded gasoline
 Fuel tank : 9.1L

Radiator (water cooler): 1.4 to 1.45 L coolant (standard concentration 50%)
 Reserve tank cooler : 300cc +/- 20cc coolant (standard concentration 50%)

Brake(F/R) : Disc/Disc
 F. Brake operation : Front R side hand lever for front wheeler
 F/R operation : Foot rest R side foot pedal for 4 wheeler

Tire : Tubeless
 Front/Rear : (F) AT 21x7-10, or AT 22x7-10, or 175/70-10
 (R) AT 22x10-10, or AT 21x10-8, or AT 22x11-10, or 255/60-10, or

20x10-9
 Chassis : Steel tube frame
 Rider : Single rider is recommend by maker (E/e Mark is double rider)

Head Light : 12V 35/35W * 1 (Option)
 Rear Light : 12V 21/5W * 1 (Option)
 Flasher Light : 12V 10W * 4 (Option)



2-1-2. Auto Speed CVT Engine (300LV/250LV)

Dimension : 1730mm/1070mm/1080mm
 Seat height : 885mm
 Wheel base : 1130mm
 Weight : 300LV = 202kg; 250LV = 202kg

Engine : 4 Stroke Liquid Cooled
 Cylinder : Twin – Vertical (Forward Inclined)
 Bore * Stroke : 300LV = single 75 x 65.2mm; 250LV = single 72.7 x 60mm
 Displacement : 300LV = 288cc; 250LV = 249cc
 Carburetor : Keihin PTG-017 or Walbro PZ 30B12

Spark : NGK DPR7EA-9 x 1
 Starting : Electrical starter and recoil back up system
 Ignition : Ignition unit
 Generator : ACG Fly Wheel Magneto
 Battery : YUASA YTX 9A-BS or GTX9L-BS

Engine Oil : 4 Stroke SAE 15W40; API SG/CD
 Engine Oil : at change (1.4L) at disassembly (1.6L)
 Air-Filter : Wet type element
 Transmission Gear Oil : SAE # 90; at change (0.3L) at disassembly (0.4L)

Transmission (F-N-R) : F/N/R shift selector function with Brake and R speed limited 15km/hr.

Fuel : Unleaded gasoline
 Fuel tank : 9.1L

Radiator (water cooler): 1.1 to 1.2 L coolant (standard concentration 50%)
 Reserve tank cooler : 300cc +/- 20cc coolant (standard concentration 50%)

Brake(F/R) : Disc/Disc
 F. Brake operation : Front R side hand lever for front wheeler
 F/R operation : Foot rest R side foot pedal for 4 wheelers

Tire : Tubeless
 Front/Rear : (F) AT 21x7-10, AT 22x7-10, or 175/70-10
 (R) AT 22x10-10, AT 21x10-8, AT 22x11-10, 255/60-10, or 20x10-9

Chassis : Steel tube frame
 Rider : Single rider is recommend by maker (E/e Mark is double rider)

Head Light : 12V 35/35W * 1 (Option)
 Rear Light : 12V 21/5W * 1 (Option)
 Flasher Light : 12V 10W * 4 (Option)



2-2-1. Location & Cable Routing Gear Engine

<5 Speeds Gear water cooled Engine (300L/250L) - 1>

- | | |
|----------------------|--------------------------|
| 01. Clutch cable | 02. Parking brake cable |
| 03. Rear brake cable | 04. Throttle switch lead |
| 05. Throttle cable | 06. Clutch lever |
| 07. Flasher relay | 08. Start switch |
| 09. Wire harness | 10. C.D.I |
| 11. Reserve tank | 12. Radiator IN hose |
| 13. Radiator cap | 14. Thermostat |
| 15. Water pump IN | |

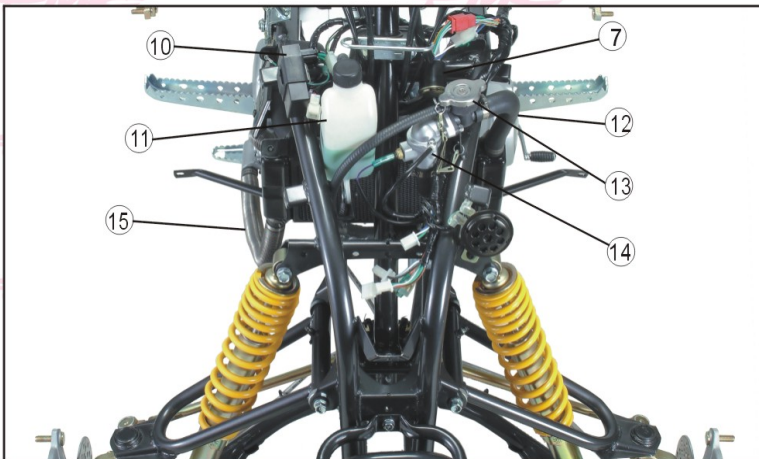
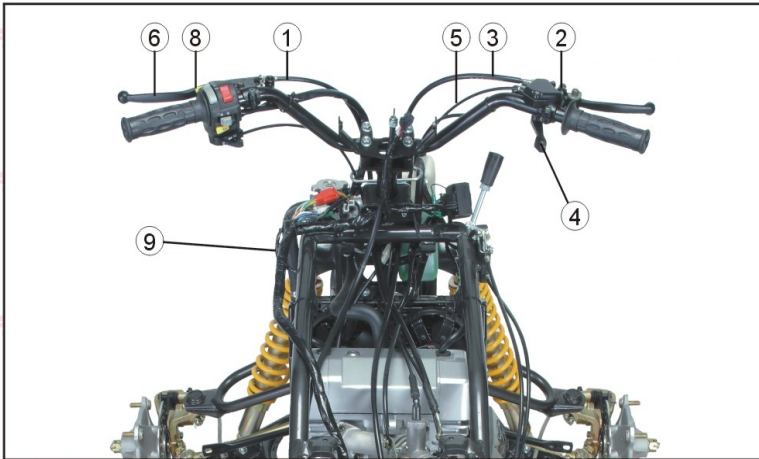

<5 Speeds Gear water cooled Engine (300L/250L)- 2>

- | | |
|-------------------------------|-------------------------------|
| 16. Radiator | 17. Thermostatic switch |
| 18. Motor Fan | 19. Water pump |
| 20. Engine case breather hose | 21. Regulator |
| 22. Starter relay switch | 23. Battery cable |
| 24. Rear/brake light lead | 25. R. front brake fluid hose |
| 26. L. front brake fluid hose | 27. Rear brake fluid hose |
| 28. R. front brake caliper | 29. L. front caliper |
| 30. Rear brake caliper | 31. Rear brake cable |

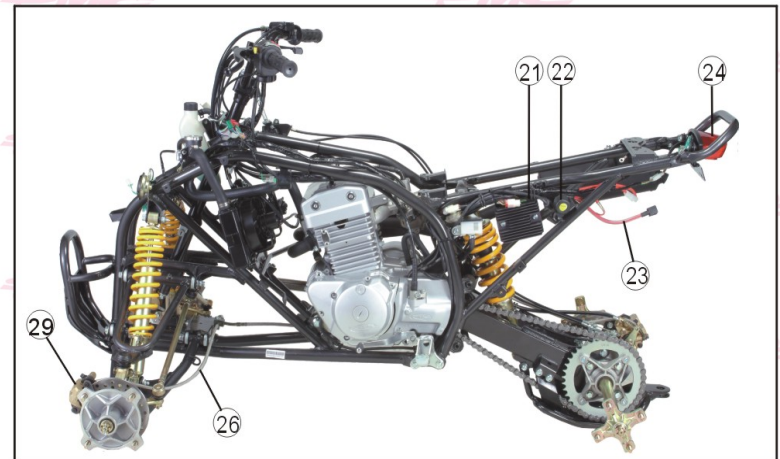
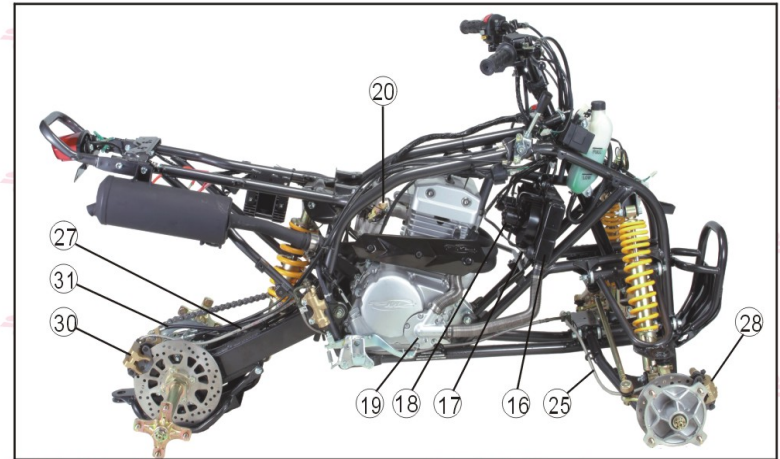



<5 Speeds Gear water cooled Engine (300L/250L)- 3>

- | | |
|-------------------------|-------------------------|
| 32. Switch selector | 33. Shift cable |
| 34. Reverse lamp switch | 35. Drive sprocket base |
| 36. Reverse gear box | 37. Gear cable holder |
| 38. Shift lever | |

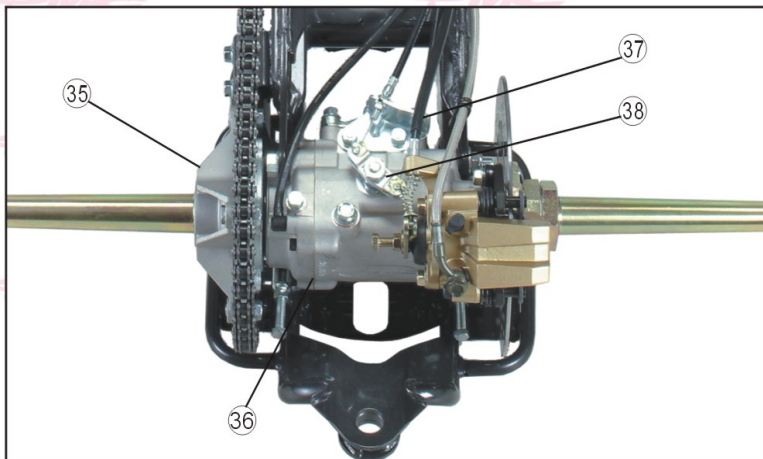
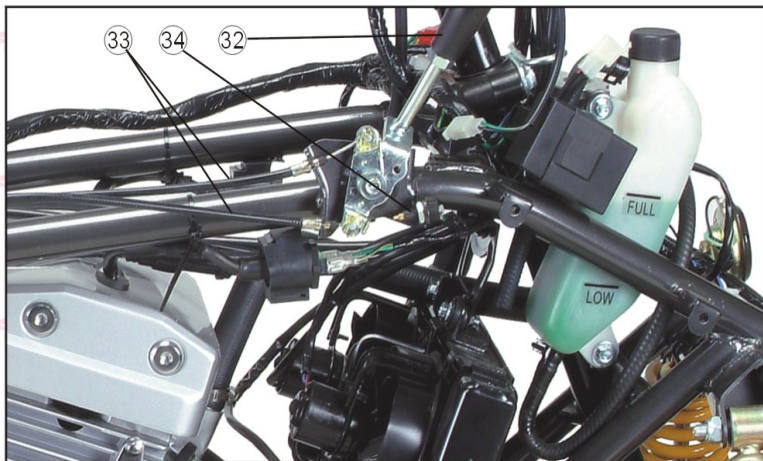

2-2-2. Location & Cable Routing CVT Engine

<Auto Speeds CVT water cooled Engine (300LV/250LV) - 1>

- | | |
|-------------------------|---------------------------------|
| 01. Chock cable | 02. Parking brake cable |
| 03. Rear brake cable | 04. Throttle switch lead |
| 05. Throttle cable | 06. Handle switch |
| 07. Wire harness | 08. Flasher relay |
| 09. Ignition units | 10. Reserve tank |
| 11. Radiator cap | 12. AICV control solenoid valve |
| 13. Radiator | 14. Radiator protector |
| 15. Thermostatic switch | |

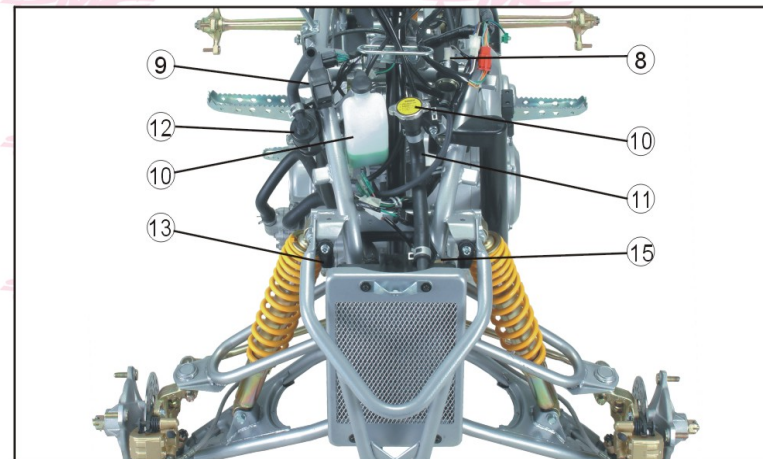
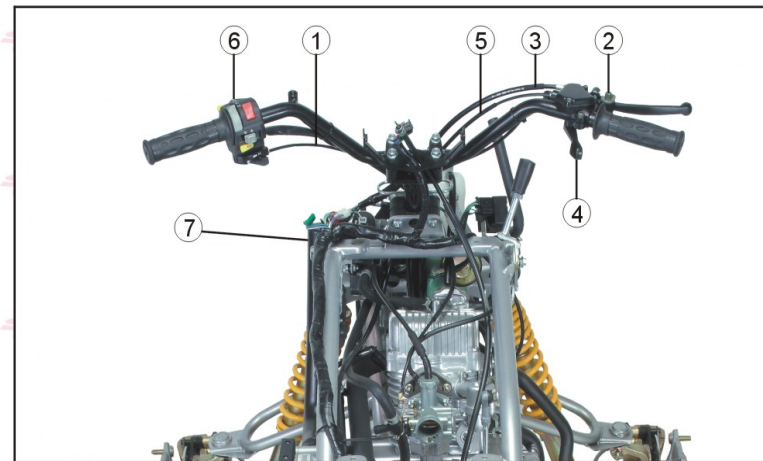



<Auto Speeds CVT water cooled Engine (300LV/250LV) - 2>

- | | |
|-------------------------------|-------------------------------|
| 16. Fan motor | 17. Air vent tube IN |
| 18. Air vent tube EX | 19. Oil catch |
| 20. Ignition coil | 21. Regulator |
| 22. Starter relay | 23. Battery cable |
| 24. Rear/brake light lead | 25. R. front brake fluid hose |
| 26. L. front brake fluid hose | 27. Rear brake fluid hose |
| 28. R. front brake caliper | 29. L. front caliper |
| 30. Rear brake caliper | 31. Rear brake cable |

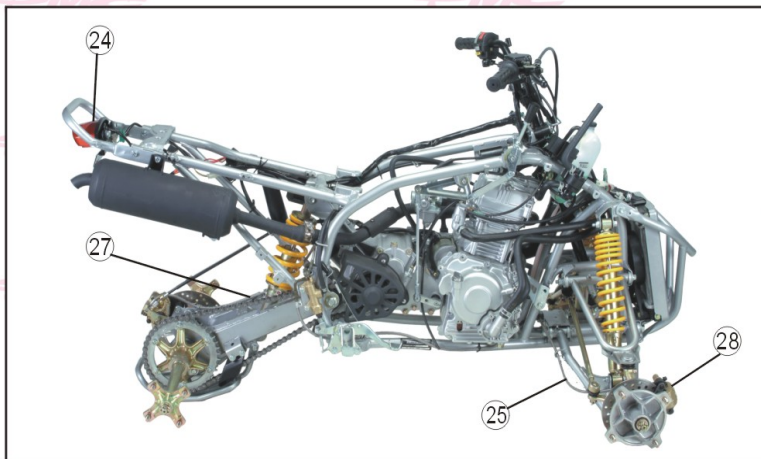
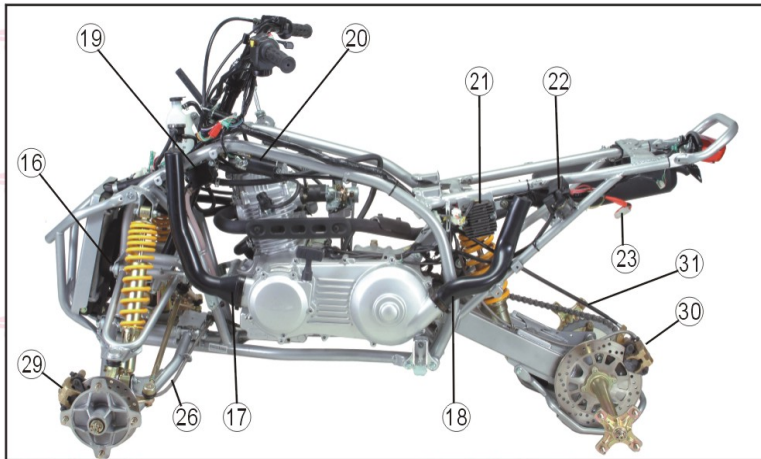

<Auto Speeds CVT water cooled Engine (300LV/250LV) - 3>

- | | |
|----------------------|--|
| 32. Switch selector | 33. Sub-shift lever |
| 34. Main shift lever | 35. Thermostat |
| 36. Radiator hose IN | 37. Inlet hose |
| 38. Water pipe | 39. AICV (air injection control valve) |
| 40. Air vent tube IN | |

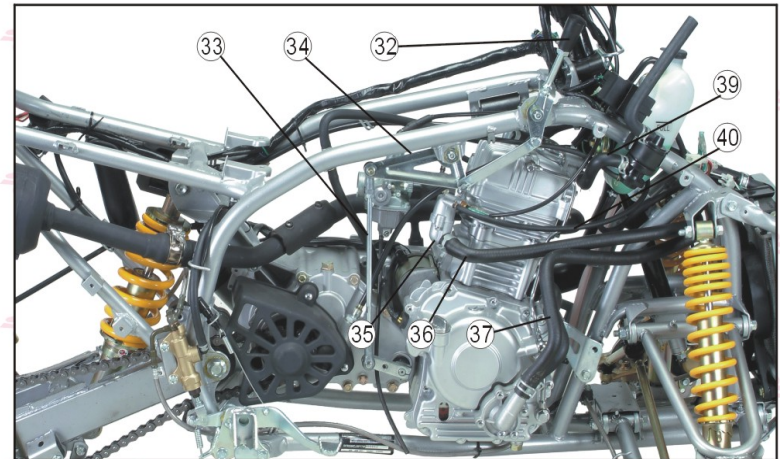



2-3. Torque Value

2-3-1. Gear Engine Parts Torque Value

Item	q'ty	Thread Dia.	Torque
Lubrication system:			
oil pump mounting screw	03	06 * 1.00mm	1.0 kg-m
Cylinder head/valves:			
spark plug	02	10 * 1.25mm	1.2 kg-m
valve adjuster lock nut	04	05 * 0.80mm	1.0 kg-m
cylinder head/camshaft holder	08	08 * 1.25mm	2.3 kg-m
cylinder head bolt	03	06 * 1.00mm	1.2 kg-m
cam sprocket bolt	02	07 * 1.00mm	2.0 kg-m
cylinder head cover bolt	02	06 * 1.00mm	1.0 kg-m
air seal head side cover bolt	04	06 * 1.00mm	1.0 kg-m
Clutch/Gearshift linkage:			
clutch lifter bolt	04	01 * 1.00mm	1.2 kg-m
clutch center lock nut	01	16 * 1.00mm	7.4 kg-m
shift drum stopper arm bolt	01	06 * 1.00mm	1.2 kg-m
gearshift return spring pin	01	08 * 1.25mm	2.5 kg-m
primary drive gear lock nut	01	16 * 1.00mm	5.3 kg-m
Crankcase/Crankshaft:			
drive sprocket bolt	02	06 * 1.00mm	1.2 kg-m
oil drain bolt	01	12 * 1.50mm	2.5 kg-m
crankshaft mounting bolt	05	08 * 1.25mm	2.3 kg-m
crankshaft mounting nut	01	06 * 1.00mm	1.2 kg-m
oil passage plate mou. screw	03	06 * 1.00mm	1.0 kg-m
Alternator/starter clutch:			
flywheel bolt	01	10 * 1.25mm	5.9 kg-m
starter clutch mounting screw	03	06 * 1.00mm	0.9 kg-m
stator mounting bolt	03	05 * 0.80mm	0.6 kg-m
stator wire clamp bolt	01	05 * 0.80mm	0.6 kg-m
ignition pulse gen. mounting bolt	02	06 * 1.00mm	1.0 kg-m
stator motor terminal nut	01	06 * 1.00mm	0.6 kg-m



2-3-2. CVT Engine Parts Torque Value

Item	q'ty	Thread Dia.	Torque	Remark
Stud bolt	04	08mm	0.9 kg-m	
Seat ball stopper bolt	01	14mm	4.8 kg-m	
L cover bolt	10	06mm	1.2 kg-m	
Camshaft holder nut	04	08mm	2.5 kg-m	Apply oil
Tappnet ADJ nut	02	05mm	0.9 kg-m	Apply oil
Pivot tension bolt	01	08mm	1.0 kg-m	
Lifter tension bolt	02	06mm	1.2 kg-m	
Lifter tension cap	01	06mm	0.4 kg-m	
Mission case bolt	09	08mm	2.7 kg-m	
Mission fill & drain bolt	02	12mm	2.0 kg-m	
Driver face nut	01	14mm	9.5 kg-m	Apply oil
Clutch outer nut	01	12mm	5.5 kg-m	
Drive plate nut	01	28mm	5.5 kg-m	
ACG flywheel nut	01	14mm	6.0 kg-m	
Spark plug	01	12mm	1.8 kg-m	
Water pump impeller	01	07mm	1.2 kg-m	L thread
Oil drain plug	01	12mm	2.5 kg-m	
Oil pump screw	01	03mm	0.2 kg-m	
Head stud bolt (IN)	02	06mm	0.9 kg-m	
Head stud bolt (EX)	02	08mm	0.9 kg-m	
ACG starter	03	05mm	0.9 kg-m	

2-3-3. Standard Torque Value

Type	Torque(kg-m)	Type	Torque(kg-m)
05mm bolt, nut	0.45-0.60	05mm screw	0.45-0.60
06mm bolt, nut	0.80-1.20	06mm nut, SH bolt	1.00-1.40
08mm bolt, nut	1.80-2.00	06mm flange bolt, nut	0.70-1.10
10mm bolt, nut	3.00-4.00	08mm flange bolt, nut	2.00-3.00
12mm bolt, nut	5.00-6.00	10mm flange bolt, nut	3.50-4.50
14mm bolt, nut	7.00	10mm flange bolt, nut	7.00



2-3-4. Chassis Parts Torque Value

Item(s)	q'ty	Thread Dia.	Torque
Steering column holder and frame	02	08 * 1.25mm	2.3 kg-m
Steering column and handlebar	01	10 * 1.25mm	3.0 kg-m
F. shock absorber(upper & lower)	04	10 * 1.25mm	4.5 kg-m
Front arm(upper-frame)	02	10 * 1.25mm	3.0 kg-m
Steering Knuckle and upper arm	02	10 * 1.25mm	4.8 kg-m
Front arm(lower-frame)	02	10 * 1.25mm	3.0 kg-m
Steering Knuckle and lower arm	02	10 * 1.25mm	2.5 kg-m
Joint rod L & R	04	10 * 1.25mm	3.8 kg-m
Tie-rod(locknut)	04	10 * 1.25mm	2.5 kg-m
Tire-rod end and steering column	04	10 * 1.25mm	3.0 kg-m
Front hub	02	14 * 1.50mm	7.0 kg-m
Front wheel	08	10 * 1.25mm	4.5 kg-m
Rear collar wheel	02	14 * 1.50mm	12. kg-m
Rear wheel	08	10 * 1.25mm	4.5 kg-m
Front shield bolt	03	08 * 1.25mm	2.6 kg-m
Rear shield bolt	03	08 * 1.25mm	2.6 kg-m
Engine Mounting			
F. engine and frame	01	12 * 1.25mm	4.5 kg-m
Swing-Arm	01	14 * 1.50mm	8.5 kg-m
Under guard	04	08 * 1.25mm	2.3 kg-m
Chain supporter	02	08 * 1.25mm	1.5 kg-m
Tensioner	02	08 * 1.25mm	0.9 kg-m
Footrest L & R	04	10 * 1.25mm	5.5 kg-m
Rear shock absorber(upper) bolt	01	10 * 1.25mm	2.5 kg-m
Rear axles hexagon nut (IN)	02	33 * 1.50mm	5.0 kg-m
(EX)	02	33 * 1.50mm	19. kg-m
(IN-EX)	02	33 * 1.50mm	24. kg-m
Sprocket axles	06	08 * 1.50mm	2.4 kg-m
Rear axles(upper and lower)	02	08 * 1.50mm	5.0 kg-m
Disc and brake	04	08 * 1.25mm	2.8 kg-m
Caliper	02	08 * 1.25mm	2.8 kg-m
Caliper bracket	02	08 * 1.25mm	2.3 kg-m
Exhaust pipe holder(frame)	02	08 * 1.25mm	2.3 kg-m
Handlebar holder	02	08 * 1.25mm	2.0 kg-m



2-4. Special Tools -- OPTION (reference)

(01). ignition timing light	(02). cylinder valve adjuster
(03). pocket tester	(04). rpm tester
(05). micrometer(25-50mm)	(06). dial gauge(1/100mm)
(07). magnetic stand	(08). micrometer(0-25mm)
(09). cylinder bore gage	(10). V-block
(11). impact driver set	(12). snap ring pliers
(13). snap ring pliers	(14). thickness gauge
(15). thickness gauge	(16). bearing installer
(17). bearing installer	(18). piston pin puller
(19). bearing installer	(20). bearing installer
(21). crankcase installer	(22). bearing remover
(23). flywheel remover	(24). bearing remover
(25). bearing remover	(26). Attachment (5 mm.)
(27). bond(quick gasket)	(28). manual

- NOTE:

1. The replacement owner's manual and tool kit are available from each Area Importer or Territorial Distributor.
2. The parts lists are available from each Area Importer or Territorial Distributor.
3. Be sure to use only genuine maker parts for replacement.



PART 3. PERIODIC MAINTENANCE

3-01. Periodic Maintenance

Be sure to perform periodic inspections and maintenances as the manual suggestion.

- 1). "*" should be settled by local dealer or service station
- 2). "I" should be inspect and clean, adjust, replaced or lubricate when it is necessary.
- 3). "C" clean
- 4). "R" replace
- 5). "A" Adjust
- 6). "L" Lubricate

PS1: 4-Stroke engine oil viscosity: SAE 10W-40, a qualified synthetic oil is strongly recommended. 4 stroke engine oil is a major factor affecting the engine performance and service life.

PS 2: Air cleaner requires more frequently cleaning or replacement after riding on (1) dusty rain days (2) sand area (3) snow days

PS 3: Air cleaner tube requires more frequently checking on (1) very wet (2) muddy conditions

PS 4: Brake fluid replaces every 2 years period.

PS 5: Check battery before riding ATV. Re-charge battery or replace a new battery, if it necessary.

PS 6: Check revers gear box operation. Adjust the movement cable, if it necessary.

PS 7: Always keeps the coolant level between Max. and Min. mark (coolant reservoir), replace or add coolant or distilled water, if it necessary. Replace all new coolant every 16-20 months! Only use the distilled water to mix coolant (standard concentration 50%)

PS 8: LCD speedometer: be sure to check and understand all function

PS 9: Transmission gear oil is for CVT engine



Table of periodical check & service

Item(s)	*	100	1000	2000	-(every 1000 km)	Remark
		20	100	200	-(every 100 hrs)	
01. Engine oil		R	R	R	R	PS1
02. Engine oil filter		C	C	C	C	
03. Engine idle speed	*	I	I	I	I	
04. Valve clearance	*	I	I	I	I	
05. Spark plug			I	I	I	
06. Air cleaner			C	C	C	PS2
07. Air cleaner tube			I	I	I	PS3
08. Carburetor & choke	*	I	I	I		
09. Throttle lever	*	I	I	I		
10. Speed limiter	*		I	I		
11. Fuel line	*			I	I	
12. Upper A arm	*	L	L	L		
13. Lower A arm	*	L	L	L		
14. Rear brake fluid	*		I	I	I	PS4
15. Steering	*			I	I	
16. Brake function	*	I	I	I	I	PS2
17. Brake shoe	*	I	I	I		
18. Shift selector	*	I	I	I	I	
19. Suspension	*	I	I	I	I	
20. Wheel/tire	*	I	I	I	I	
21. Nuts, bolts, fasteners	*		I	I	I	
22. Drive chain	*	I	I	I	I	
23. Battery		I	I	I	I	PS5
24. Exhaust	*		I	I	I	
25. Control cable	*	I	I	I	I	
26. Gear oil	*	R	I	I	I	
27. Revere gear and shift selector	*	I	I	I	I	PS6
28. Coolant		I	I	I	R	PS7
29. Speedometer	*	I	I	I	I	PS8
30. Transmission gear oil		R	I	R	R	PS9

- CAUTION: Be sure to perform the initial maintenance for changing engine oil(a qualified synthetic 4-stroke oil is strongly recommended), cleaning engine oil filter, ... after 1st 20hrs (or 100km) operation. Periodic inspection, adjustment, and lubrication will keep ATV in the safest and best operation condition. Be sure to use only genuine maker parts for replacement.

- CAUTION: this is update note – the rest of detail parts refer to Oil-Cooled Engine Part 3



PART 4. GEAR ENGINE DETAILS

4-01. Fuel System and Carburetion
/NOTE: Service information

4-02. Lubrication System
/NOTE: Service Information

4-03. Engine Removal/Installation
/NOTE: Service information

4-04. Cylinder Head/Valves
/NOTE: Service information

4-05. Cylinder/Piston
/NOTE: Service information

4-06. Clutch/Gearshift Linkage
/NOTE: Service information

4-07. Alternator/Starter Clutch
/NOTE: service information

4-08. Crankcase/Crankshaft/Transmission
/NOTE: service information

4-09. Water Cooling System
/NOTE: service information
/NOTE: problems shooting <Q-A>
/ 01. Radiator cap inspection
/ 02. Radiator inspection
/ 03. Radiator removal
/ 04. Radiator disassembly
/ 05. Thermostatic switch
/ 06. Radiator assembly and installation
/ 07. Water pump mechanical seal inspection
/ 08. Water pump/impeller removal
/ 09. Water pump shaft removal
/ 10. Mechanical seal replacement
/ 11. Water pump shaft installation
/ 12. Water pump/impeller installation
/ 13. Thermo-sensor removal and inspection
/ 14. Thermo-sensor installation
/ 15. Thermostat removal
/ 16. Thermostat inspection
/ 17. Thermostat installation



<4-1. Fuel System and Carburetion Briefing>

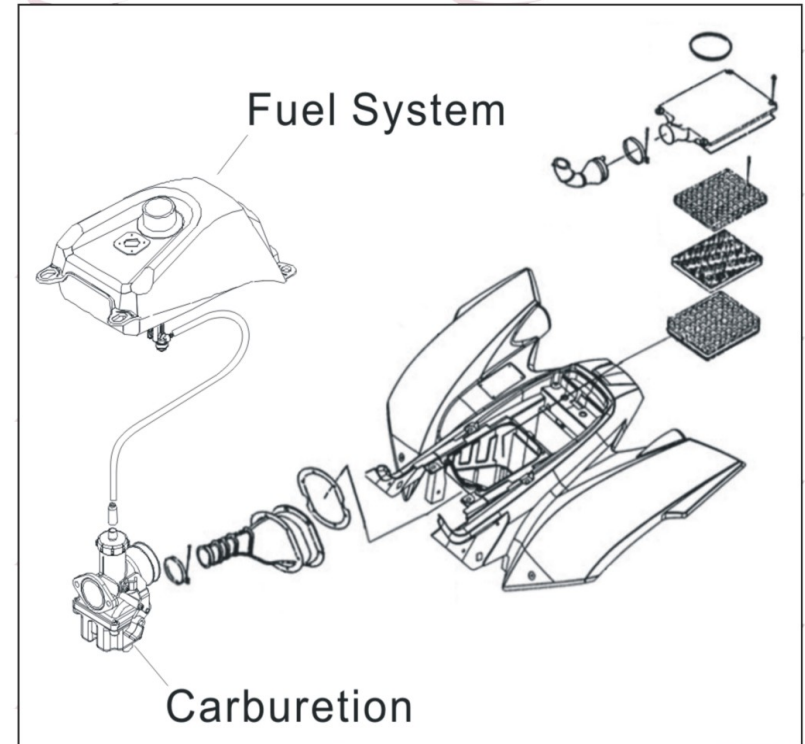



4-1. Fuel System and Carburetion

- NOTE: Service information

Maker(brand)	: 250 :250L/300L	Keihin	Keihin	Mikuni	Walbro
Type		PTG	PD-19	VM 26-672	PZ 30B12
Number install		2 (double)	1 (single)	1 (single)	1 (single)
Carburetor Float level	: 250 : 300L	12,5mm	12,5mm	32,5mm	31,5mm
Main jet	: 250 : 300L	# 102	# 108	# 110	# 108
Slow jet	: 250 : 300L	# 35	# 40	# 15 # 15	# 38 # 38
Idle speed	: 250 : 300L	On 1500 +/- 300 rpm		On 1500 +/- 100 rpm	
Throttle grip free play	: 250	2-6 mm			
Air screw opening	: 250 : 300L	On 1 3/4 +/- 1/2		On 1 1/2 +/- 1/2	

- NOTE: Water cooled engine, 2 kinds of carburetor could be installed on vehicle. Oil cooled engine, 4 kinds of carburetor could be installed on vehicle.

- CAUTION: this is update note – the rest of detail parts refer to Oil-Cooled Engine

4-01. Fuel System and Carburetion

/ NOTE: Service information

/ NOTE: Problems shooting <Q-A>

/ 01. Throttle disassembly

/ 02. Carburetor removal

/ 03. Float/float inspection

/ 04. Jets/air screw/throttle screw removal

/ 05. Fuel outlet ball removal and inspection

/ 06. Slow/Main jet installation

/ 07. Choke

/ 08. Float level inspection

/ 09. Carburetor installation

/ 10. Throttle valve installation

/ 11. Fuel tank

/ 12. Air cleaner cleaning



<4-2. Lubrication System Briefing>

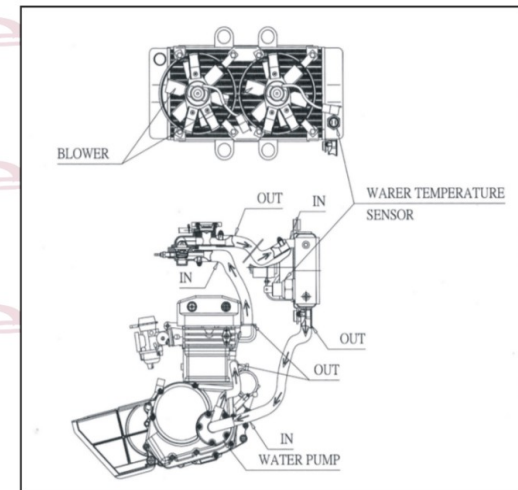
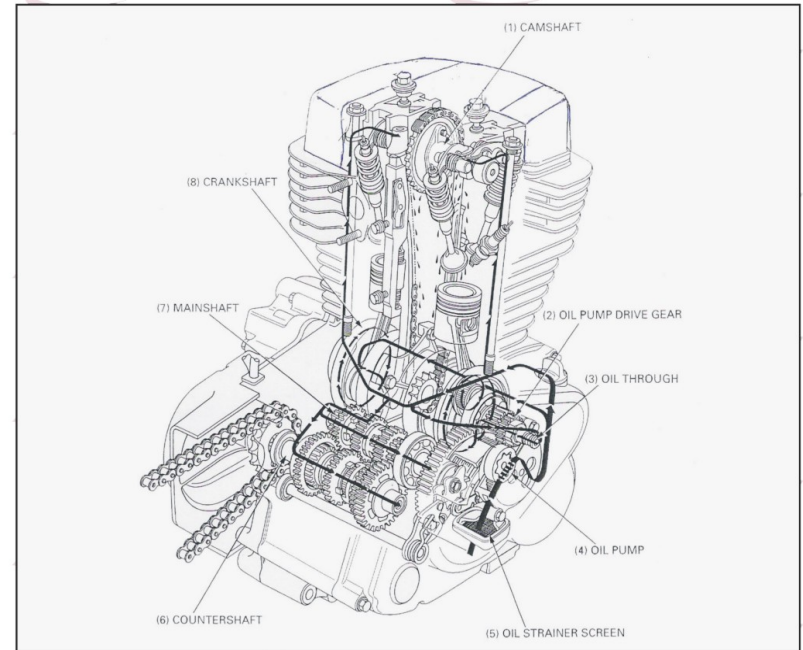



4-2. Lubrication System

NOTE: Service Information

01.Engine oil capacity(air/oil/water cooled)			
Air cooled		Oil cooled	Water cooled
At draining	: 1.6 liter	: 1.7 liter	: 1.6 liter
At disassembly	: 1.8 liter	: 2.0 liter	: 1.8 liter
02.Recommended engine oil : a qualified synthetic 4-stroke oil or equivalent motor oil			
03.API service classification SF or SG Viscosity : SAE 10W-40			
04.Oil pump rotor	: Standard (mm/in)	Service Limited	
/tip clearance	: 0.15(0.006)	0.20 (0.008)	
/body clearance	: 0.15-0.21(0.006-0.008)	0.25 (0.010)	
/side clearance	: 0.05-0.13(0.002-0.005)	0.14 (0.006)	
05.Torque Value			
/Oil drain bolt : 25N-m (2.5 kg-m , 18 lbf-ft)			
/Oil mounting screw : 10N-m (1.0 kg-m , 7 lbf-ft)			

- CAUTION: Used or incorrect engine oil may cause skin cancer if repeatedly left in contact with the skin for prolonged periods.

- CAUTION: this is update note – the rest of detail parts refer to Oil-Cooled Engine

- 4-02. Lubrication System
- / NOTE: Service Information
- / NOTE: Problems shooting <Q-A>
- / 01. Oil pump removal
- / 02. Oil pump disassembly
- / 03. Oil pump inspection
- / 04. Oil pump assembly
- / 05. Oil pump installation



4-3. Engine Removal/Installation

- NOTE : Service Information

01.Engine oil capacity(air/oil/water-cooled)			
	- Air cooled	- Oil cooled	-Water cooled
at draining	: 1.6 liter	: 1.7 liter	: 1.6 liter
at disassembly	: 1.8 liter	: 2.0 liter	: 1.8 liter
02.Engin weight at	: 41.5kg(91.5lbs)		: 42.35kg(93.4lbs)
03.Torque Values			
/Exhaust pipe joint nut	: 14 N.m(14 kgf.m,10 lbf.ft)		
/Engine rear mounting nut	: 83 N.m(8.5 kgf.m,61 lbf.ft)		
/Gearshift pedal pivot nut	: 22 N.m(2.2 kgf.m,16 lbf.ft)		
/Drive sprocket bolt	: 12 N.m(1.2 kgf.m,09 lbf.ft)		

- CAUTION: this is update note – the rest of detail parts refer to Oil-Cooled Engine

4-03. Engine Removal/Installation

- / NOTE: Service information
- / NOTE: Problems shooting <Q-A>
- / 01. Engine removal
- / 02. Engine installation

<4-04. Cylinder Head/Valves>

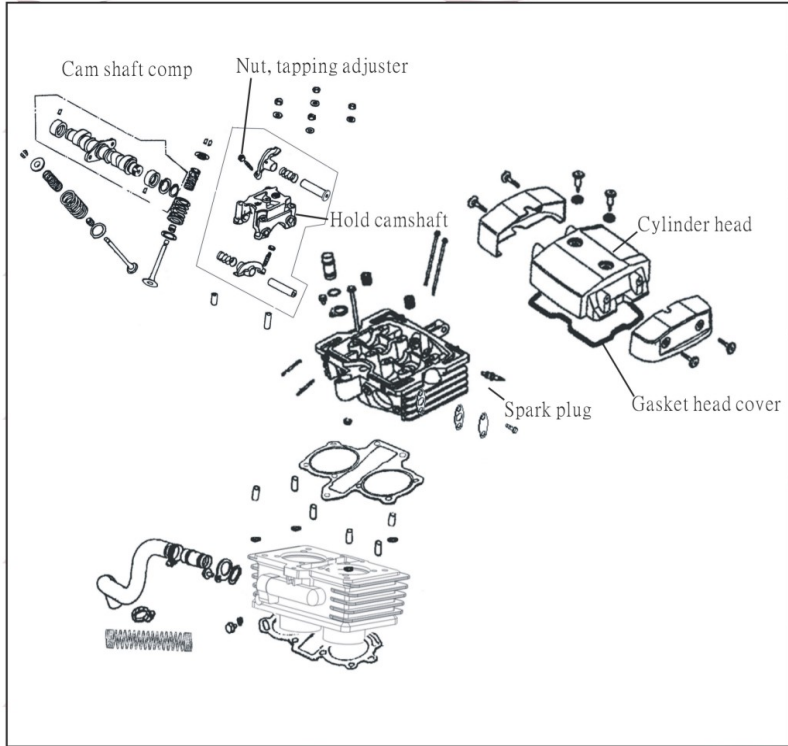

4-4. Cylinder Head/Valves

- NOTE: Service Information 250L/300L

ITEM	STANDARD	SERVICE LIMIT(mm/in)
Cylinder compression	1,100 kpa (11.2kg/cm,159psi) at 600rpm	-----
Cylinder head warpage	-----	0.10(0.004)
Valve clearance	IN/EX: 0.06-0.10(0.002-0.004)	-----
Valve stem O.D.	IN : 5.450-5.465(0.21460-0.2152) EX : 5.430-5.445(0.2138-0.2144)	5.42(0.213) 5.40(0.213)
Valve guide I.D.	IN : 5.475-5.485(0.2156-0.2159) EX : 5.475-5.485(0.2156-0.2159)	5.50(0.217) 5.50(0.217)
Stem-guide	IN : 0.010-0.035(0.0000-0.0014)	0.08(0.003)
Clearance	EX : 0.030-0.055(0.0012-0.0022)	0.10(0.004)
Valve seat w.	IN/EX: 1.0-1.1(0.039-0.043)	1.80(0.07)
Valve spring Inner	IN/EX : 29.9(1.18)	29.0(1.14)
Free length Outer	IN/EX : 38.2(1.50)	37.0(1.46)
Rocker arm Rocker arm I.D.	IN/EX : 10-10.015(0.3937-0.3943)	10.1(0.398)
Rocker arm shaft O.D.	IN/EX : 9.972-9.987(0.3926-0.3932)	9.91(0.390)
Rocker arm-to-shaft clearance	IN/EX : 0.013-0.043(0.0005-0.0017)	0.05(0.002)
<Camshaft>		
Cam lobe height	IN : 27.383-27.543(1.0781-1.0844) EX : 27.209-27.369(1.0712-1.0775)	27.10(1.07) 27.00(1.06)
Run-out	-----	0.05(0.002)
Journal O.D.	19.967-19.980(0.7861-0.7866)	19.92(0.784)
Bushing I.D.	20.063-20.083(0.7899-0.7907)	20.20(0.795)
Torque Values		
Valve adjuster lock nut		10N.m(1.0kgf.m,07 lbf.ft)
Cylinder head/ Camshaft holder nut		23N.m(2.3kgf.m,17 lbf.ft)
Cylinder head bolt		12N.m(1.2kgf.m,09 lbf.ft)
Cam sprocket holt		20N.m(2.0kgf.m,14 lbf.ft)
-- Apple a locking agent to the threads		



Cylinder head cover bolt	10N.m(1.0kgf.m,07 lbf.ft)
-----------------------------	---------------------------

- CAUTION:

1. Rocker arms and crankshaft can be serviced with the engine installed in the frame. The engine must be removed for servicing the cylinder head and valves.
2. When disassembling, mark and store the disassembled parts to ensure that they are reinstalled in their original locations.
3. Clean all disassembled parts with cleaning solvent and dry them by blowing them off with compressed air before inspection.
4. Rocker arm lubricating oil is fed through oil passages in the cylinder head. Clean the oil passages before assembling cylinder head and rocker arm holder.
5. Be careful not to damage the mating surfaces when removing the cylinder head cover and cylinder head.

- CAUTION: this is update note – the rest of detail parts refer to Oil-Cooled Engine

- 4-04. Cylinder Head/Valves
- / NOTE: Service information
- / NOTE: Problems shooting <Q-A>
- / 01. Cylinder compression test
- / 02. Rocker arm/camshaft removal
- / 03. Rocker arm/camshaft inspection
- / 04. Cylinder head removal
- / 05. Cylinder head disassembly
- / 06. Cylinder head inspection
- / 07. Valve spring inspection
- / 08. Valve/Valve guide inspection
- / 09. Valve guide replacement
- / 10. Valve seat inspection/re-facing
- / 11. Valve seat re-facing
- / 12. Cylinder head assembly
- / 13. Cylinder head installation
- / 14. Rocker arm holder assembly
- / 15. Camshaft installation
- / 16. Camshaft holder installation



<4-5. Cylinder/Piston>

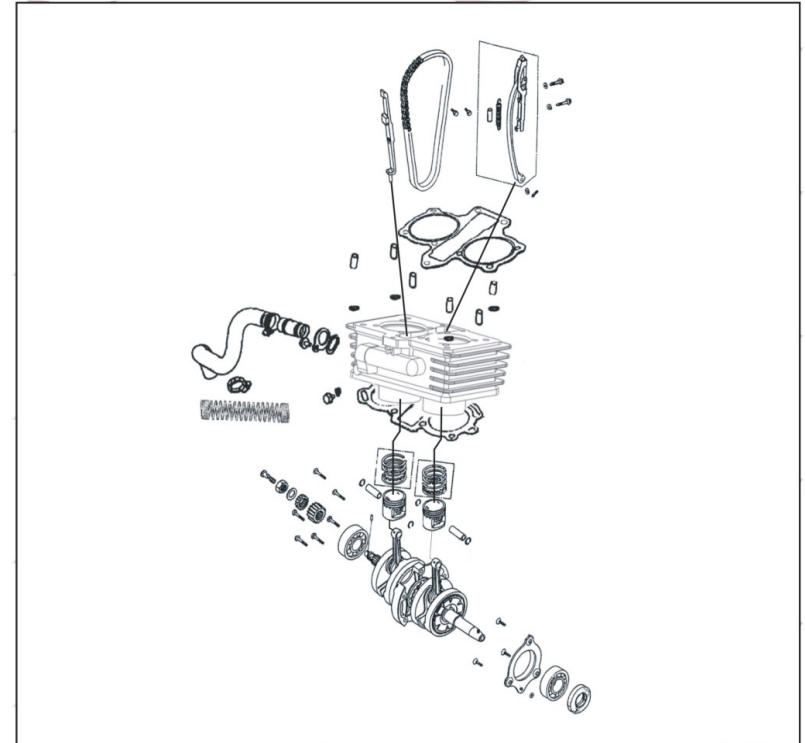



4-05. Cylinder/Piston

- NOTE: Service Information

Items	Standard(mm/in)	Service Limited(mm/in)
<Cylinder>		
01 I.D. 250cc	53.000-53.010(2.0866-2.0870)	53.10mm(2.091)
01 I.D. 300cc	53.000-53.010(2.0866-2.0870)	57.10mm(2.248)
02. Out of round	-----	0.05mm(0.002)
03. Taper	-----	0.05mm(0.002)
04. Warpage	-----	0.05mm(0.002)
<Piston/Piston Ring>		
01. Piston mark direction	IN facing intake side	
02. Piston O.D.	52.970-52.990mm(2.0854-2.0862)	52.90mm(2.083)
03. Piston OD. measurement	10mm(0.4in)from skirt bottom point	
04. Piston pin bore I.D.	15.002-15.008mm(0.2906-0.5909)	15.05mm(0.593)
05. Piston pin O.D.	14.994-15.000mm(0.5903-0.5906)	14.98mm(0.590)
06. Piston-to-piston pin clearance	0.002-0.014mm(0.0001-0.0006)	0.07mm(0.003)
07. Piston ring-to-ring(T) Groove clearance	0.015-0.045mm(0.0006-0.0018)	0.10mm(0.004)
(2)	0.015-0.050mm(0.0006-0.0020)	0.10mm(0.004)
08. Piston ring end (TOP) Gap (2nd.)	0.15-0.30mm(0.006-0.012)	0.45mm(0.018)
Oil (side rail)	0.2-0.7mm(0.01-0.03)	0.90mm(0.035)
09. Cylinder-to-piston clearance	0.010-0.040mm(0.040mm)	0.10mm(0.004)
10. Connecting rod small end I.D.	15.016-15.034(0.5912-0.5919)	15.08mm(0.594)
11. Connect rod-to-piston piston clearance	0.016-0.040mm(0.0006-0.0016)	0.10mm(0.004)
12. Tool	Piston base	

- Caution:

1. Cylinder head lubricating oil is fed through an oil passage in the cylinder. Be sure this oil passage is not clogged and that the O-rings and dowel pins are in place before installation.
2. When disassembling, mark and store the disassembled parts to ensure they are reinstalled in their original locations.
3. Clean all disassembled parts with cleaning solvent and dry them by blowing them off with compressed air before inspection.



- CAUTION: this is update note – the rest of detail parts refer to Oil-Cooled Engine

4-05. Cylinder/Piston

/ NOTE: Service information

/ NOTE: Problems shooting <Q-A>

/ 01. Cylinder removal

/ 02. Piston removal

/ 03. Cylinder inspection

/ 04. Piston inspection

/ 05. Piston ring installation

/ 06. Piston installation



<4-06. Clutch/Gearshift Linkage>

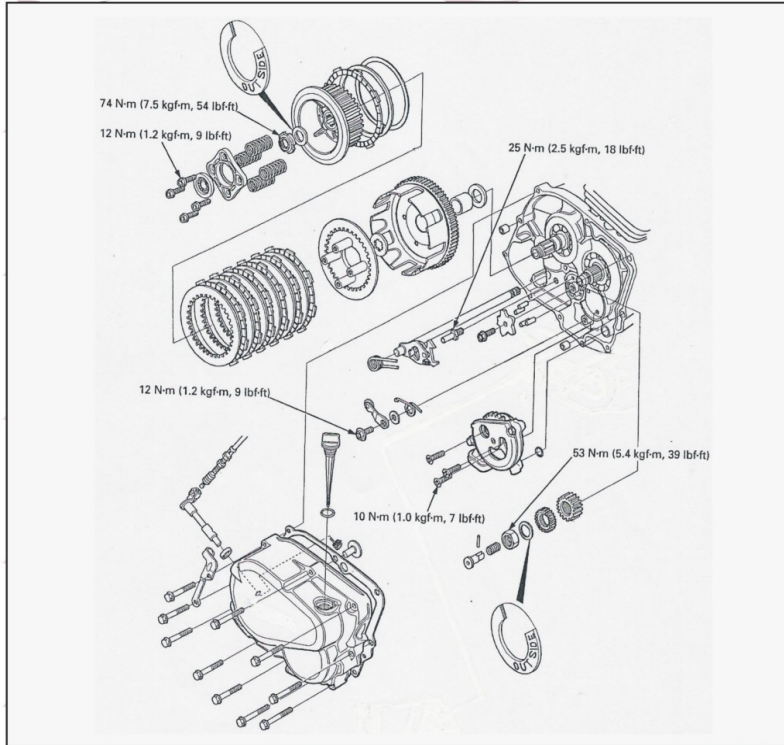

4-06. Clutch/Gearshift Linkage

- NOTE: Service Information

Item(s)	Standard(mm/in)	Service Limited
01. Clutch lever free play	: 10-20mm(3/8-3/4)	-----
02. Clutch spring free length	: 37.8mm(1.49)	36.0mm(1.42)
03. Clutch disc thickness	: 2.92-3.08mm (0.115-0.121)	2.6mm (0.10)
04. Clutch plate warpage	:	0.20mm(0.008)
05. Clutch outer I.D.	: 26.000-26.021mm (1.0236-1.0244)	26.04mm (1.025)
06. Clutch outer guide	: 25.959-25.980mm (1.0220-1.0228)	20.05mm (1.020)
07. Torque Value		
/ Clutch lifter bolt	: 12N.m(1.2kgf-m,9 lbf.ft)	
/ Clutch center lock nut	: 74N.m(7.5kgf-m,54 lbf.ft)	
/ Shift drum stopper arm bolt	: 12N.m(1.2kgf-m,9 lbf.ft)	
/ Gearshift return spring pin	: 25N.m(2.5kgf-m,18 lbf.ft)	--Apply a locking agent to the threads
/ Primary drive gear lock nut	: 53N.m(5.4kgf-m,39 lbf.ft)	
08. Tolls:		
/ Clutch center holder		
/ Gear holder		
/ Lock nut wrench,20*24mm		
/ Extension bar or equivalent item		

- Caution: These services (removal and installation of the clutch, primary drive gear, oil pump drive gear and gearshift link-age) can be performed with the engine installed in the frame.



- CAUTION: this is update note – the rest of detail parts refer to Oil-Cooled Engine

4-06. Clutch/Gearshift Linkage

/ NOTE: Service information

/ NOTE: Problems shooting <Q-A>

/ 01. Right crankcase cover removal

/ 02. Clutch lifter removal/installation

/ 03. Clutch removal

/ 04. Clutch lifter bearing inspection

/ 05. Clutch spring inspection

/ 06. Clutch center inspection

/ 07. Clutch disc inspection

/ 08. Clutch pate inspection

/ 09. Clutch outer/clutch outer guide

/ 10. Clutch installation

/ 11. Primary and oil drive gear removal

/ 12. Installation primary and oil pump

/ 13. Gearshift linkage disassembly

/ 14. Gearshift linkage assembly

/ 15. Right crankcase cover installation



4-91L



4-92L



<4-07. Alternator/Starter Clutch>

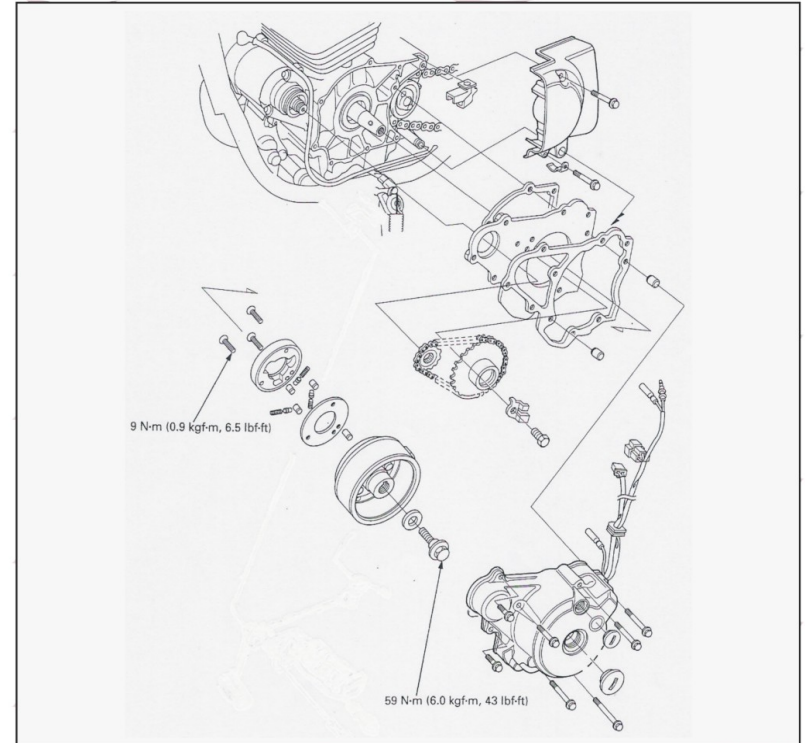

59 N·m (6.0 kgf·m, 43 lbf·ft)

9 N·m (0.9 kgf·m, 6.5 lbf·ft)



4-07. Alternator/Starter Clutch

- NOTE: Service Information

ITEM	STANDARD	SERVICE LIMIT
Starter driver I.D.	22.010-22.022mm	22.08mm
Sprocket	(0.8665-0.8670)	(0.869)
Boss O.D.	36.975-37.000mm	36.90mm
	(1.4557-1.4567)	(1.453)
Torque Values		
/ Flywheel bolt	59N.m (6.0 kgf-m, 43.0 lbf.ft)	
/ Starter clutch mounting screw	9 N.m (0.9 kgf-m, 6.5 lbf.ft)	--Apply a locking agent to the threads
/ Stator mountings screw	6 N.m (0.6 kgf-m, 4.3 lbf.ft)	
/ Stator wire clamp screw	6 N.m (0.6 kgf-m, 4.3 lbf.ft)	
/ Ignition pulse generator screw	10N.m (1.0 kgf-m, 7.0 lbf.ft)	
Tools : (1)Flywheel holder (2).Rotor puller		

- CAUTION: this is update note – the rest of detail parts refer to Oil-Cooled Engine

4-07. Alternator/Starter Clutch

/ NOTE: service information

/ NOTE: problems shooting <Q-A>

/ 01. Flywheel removal

/ 02. Stator removal

/ 03. Starter clutch removal

/ 04. Starter clutch disassembly

/ 05. Starter clutch inspection

/ 06. Starter clutch assembly

/ 07. Stator assembly

/ 08. Alternator installation

/ 09. Flywheel installation

/ 10. Left crankcase cover installation



<4-08. Crankcase/Crankshaft/Transmission>

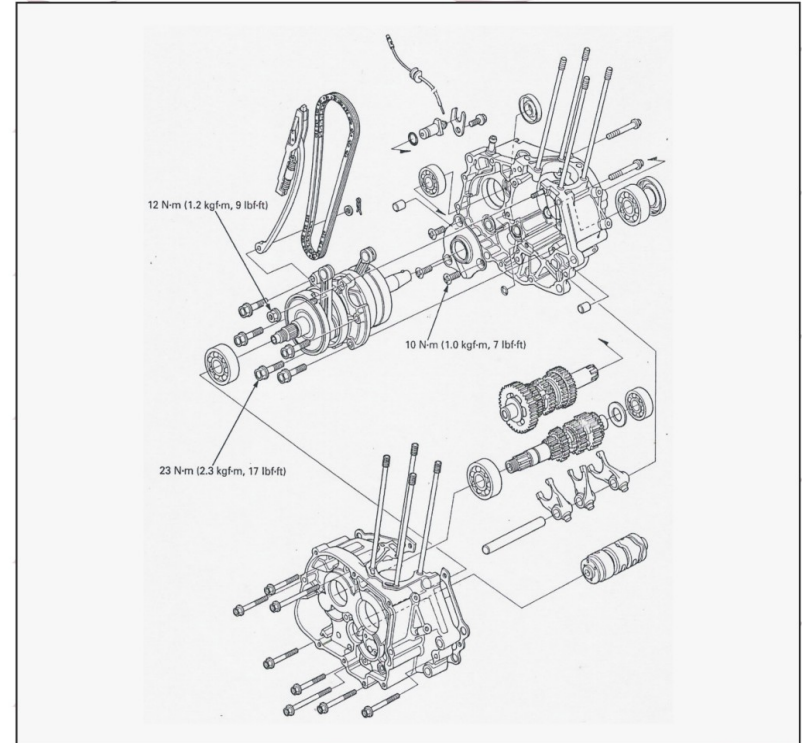



4-08. Crankcase/Crankshaft/Transmission

- NOTE: Service Information

NOTE : Service Information	Standard	Service limited
<Crankshaft>		
01. connecting rod big end side clearance	0.10-040mm (0.004-0.016)	0.60 mm (0.024)
02. radial clearance	0.004-0.012mm (0.0002-0.0005)	0.05 mm (0.002)
03. run-out both ends run-out bearing holder	-----	0.03 mm(0.001) 0.05 mm(0.002)
<Transmission>		
01. gear I.D.	M5 20.020-20.041 mm (0.7882-0.7890)	20.08 mm (0.791)
gear I.D.	C1 20.020-20.041 mm (0.7882-0.7890)	20.08 mm (0.791)
gear I.D.	C4 20.020-20.04 mm (0.7882-0.7890)	20.08 mm (0.791)
02. gear bushing O.D.	C1 19.979-20.000 mm (0.7866-0.7874)	19.93 mm (0.785)
03. gear bushing I.D.	C1 16.516-16.531 mm (0.6502-0.65009)	16.58 mm (0.653)
04. gear-bushing clearance	C1 0.20-0.0062 mm (0.0008-0.0024)	0.10 mm (0.004)
05. main-shaft O.D.	M5 19.959-19.980 mm (0.7858-0.7866)	19.91 mm (0.784)
06. countershaft O.D.	C1 16.466-16.484 mm (0.6475-0.6490)	16.41 mm (0.646)
countershaft O.D.	C4 19.959-19.980 mm (0.7858-0.7866)	19.91 mm (0.784)
07. gear-shaft clearance	M5 0.040-0.082 mm (0.016-0.0032)	0.10 mm (0.004)
gear-shaft clearance	C4 0.040-0.082 mm (0.016-0.0032)	0.10 mm (0.004)
08. bushing-shaft clearance	C1 0.032-0.068 mm (0.013-0.0027)	0.10 mm (0.004)
<Shift fork shaft>		
01. fork I.D.	12.000-12.018 (0.4724-0.4731)	12.05 mm (0.474)
fork claw thickness	4.93-5.00 (0.194-0.197)	4.80 mm (0.189)
02. fork shaft O.D.	11.976-11.994 (0.4724-0.4731)	11.93 mm (0.470)



Torque Values

- Crankshaft mounting bolt: 23 N.m (2.3kgf-m, 17 lbf.ft)
- Crankshaft mounting nut : 12 N.m (1.2kgf-m, 9 lbf.ft)
- Oil passage plate mounting screw 10 N.m (1.0 kgf-m, 7 lbf.ft)

Tools:

- Bearing remover
- Remover weight
- Attachment, 32x35mm
- Attachment, 42x47mm
- Attachment, 52x55mm
- Attachment, 62x68mm
- Pilot, 20mm
- Pilot, 22mm
- Pilot, 25mm

- Caution: For crankshaft and transmission repair, the crankcase must be separated.

- CAUTION: this is update note – the rest of detail parts refer to Oil-Cooled Engine

4-08. Crankcase/Crankshaft/Transmission

/ NOTE: service information

/ NOTE: problems shooting <Q-A>

/ 01. Crankcase separation

/ 02. Transmission removal/disassembly

/ 03. Transmission inspection

/ 04. Transmission assembly

/ 05. Transmission installation

/ 06. Crankshaft removal

/ 07. Crankshaft inspection

/ 08. Crankshaft installation

/ 09. Crankcase bearing replacement

/ 10. Right crankcase

/ 11. Left crankcase

/ 12. Drive new bearings into the left crankcase

/ 13. Install a new O-ring

/ 14. Crankcase bearing locations

/ 15. Crankcase assembly



<4-09. Water Cooled System>

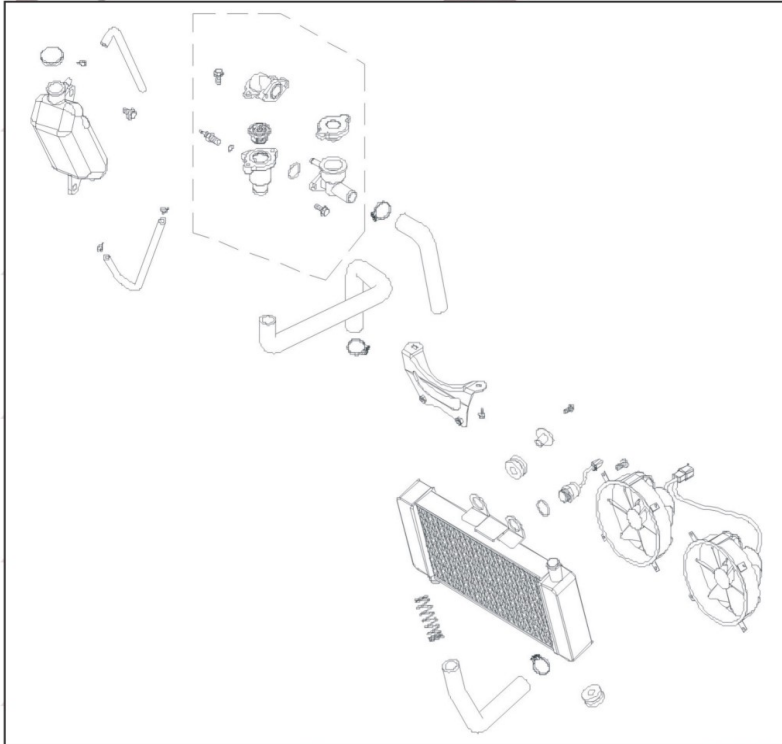

4-09. Water Cooling System

- NOTE: Service Information

1. The water pump should be serviced after removing the engine. Other cooling system service can be done without remove the engine.
2. The engine must be cool before servicing the cooling system. Be sure do not remove the engine whenever the coolant temperature is hard. And, do not remove the radiator cap either.
3. Avoid spilling coolant on painted surfaces for the coolant will damage the painted surfaces.
4. After servicing the system, check for leaks with a cooling system tester.

SPECIFICATIONS

Radiator cap relief pressure		1.1±0.15 kg/cm ²	
Thermostat temperature	Begins to open	72±2°C	
	Full-open	90°C	
	Valve lift	3.5~4.5mm	
		Total system 1600±20cc	Radiator:1300±20cc Reverse tank:300±20cc

- Cautions:

1. Use coolant of specified mixing rate. 1.4 to 1.45 L coolant (standard concentration 50%)
2. Do not mix coolant concentrate of different brands.
3. The freezing point of coolant mixture shall be 5°C lower than the freezing point of the riding area – detail refer to the Area Importer information.

Special tool: Mechanical seal driver

Torque value:

- / 1. Water pump impeller 1.0~1.4kgf-m
- / 2. Water pump cover bolt 0.8~1.2kgf-m

- NOTE: Problems shooting <Q-A>

<Q-A> Engine temperature too high?

- . Faulty temperature gauge or thermo-sensor
- . Faulty radiator cap
- . Faulty thermostat
- . Insufficient coolant
- . Passages blocked in hoses or water jacket
- . Clogged radiator fins
- . Passages blocked in radiator
- . Faulty water pump

<Q-A> Temperature gauge pointer dose not register the correct coolant temperature?

- . Faulty temperature gauge or thermo-sensor
- . Faulty thermostat



4-9-01. Radiator cap inspection (Fig. 4-161)

- / 01. Install the radiator cap onto the radiator tester and apply specified pressure to check.
- / 02. Put water on the cap sealing surface before testing.
 - * Radiator Cap Relief Pressure: 1.1±0.15 kg/cm²
- / 03. Install the radiator tester onto the radiator and apply specified pressure to it.
- / 04. Inspect the water hoses and connectors for leaks.

- Caution: The test pressure should not exceed 1.05kg/cm². Excessive pressure can damage the radiator and is hose

4-9-02. Radiator inspection (Fig. 4-162)

- / 01. Take out the front fender.
- / 02. Check the radiator soldered joints and seams if there has any leaks.
- / 03. Drive dirt out from between core fins with clogging the radiator.
- / 04. Be straighten any bent fins.

4-9-03. Radiator removal (Fig. 4-163, 4-164, 4-165, 4-166)

- / 01. Drain the coolant and take out the front fender.
- / 02. Disconnect the air vent tube from the radiator filler.
- / 03. Remove the overflow tube clamp and disconnect the over tube.
- / 04. Disconnect the fan motor wire coupler and remove 2 bolts on the radiator filler hold plate.
- / 05. Remove the two bolts on the radiator and disconnect the thermostatic switch wire leads
- / 06. Loosen the hose bands and disconnect the upper hose and lower hose from the radiator.
- / 07. Pull the radiator upward to remove the radiator.

4-9-04. Radiator disassembly (Fig. 4-167)

- / 01. Remove the three bolts and then remove the fan/shroud from the radiator.
- / 02. Check fan motor by battery.

4-9-05. Thermostatic switch (Fig. 4-168)

- / 01. When coolant temperature lower 85~90c, the thermostatic switch OFF.
- / 02. When coolant temperature over 85-90c, the thermostatic switch ON.

4-9-06. Radiator assembly and installation (Fig. 4-169, 4-170, 4-171, 4-172)

- / 01. Install the fan shroud on the radiator.
- / 02. Reverse the "RADIATOR REMOVAL" procedures
 - * the fan set is twin fan set.
- / 03. Fill the radiator with coolant and connect the vent tube to the radiator filler.
- / 04. After installation, check for coolant leaks.

- Caution: refill the coolant main points:

- (1).Take the radiator filler and the air vent tube to be separated.
- (2).Next, start the engine, filled in the coolant till the coolant flowed out from the air vent tube.
- (3).Finally, put the air vent tube on.

4-9-07. Water pump mechanical seal inspection (Fig. 4-173)

- / 01. Inspect the telltale hole for sings of mechanical seal is leaking
- / 02. Remove the right crankcase cover and replace the mechanical seal.



4-9-08. Water pump/impeller removal (Fig. 4-174, 175, 176, 177, 178, 179, 180)

- / 01. Drain the coolant , loosen the bolts and the water pump cover.
 - / 02. Remove the gasket and 2 dowel pins
 - / 03. Remove the water pump impeller, washer and seal washer (porcelain).
 - * The impeller has left hand threads.
 - / 04. Inspect the mechanical(water) seal and seal washer for or damage.
- Caution: The mechanical seal and seal washer must be replace as a new set.

4-9-09. Water pump shaft removal (Fig. 4-181, 4-182)

- / 01. Remove the water pump impeller and disconnect the water hose.
- / 02. Remove the bolts attaching the right crankcase cover.
- / 03. Remove the water pump bearing snap ring from the water pump assembly.
- / 04. Remove the water pump shaft and inner bearing.
- / 05. Remove the water pump shaft outer bearing.

4-9-10. Mechanical seal replacement (Fig. 4-180)

- / 01. Drive the mechanical seal out of the water pump assembly from the inside.
- / 02. Drive in a new mechanical seal using a mechanical seal drive.
- / 03. Apply sealant to the right crankcase cover fitting surface of a new mechanical seal and then drive in the mechanical seal.

4-9-11. Water pump shaft installation (Fig. 4-179)

- / 01. Drive a new water pump shaft outer bearing into the water pump assembly from the inside.
- / 02. Install the water pump shaft and shaft inner bearing into the waster pump assembly.
- / 03. Install the snap ring to secure the inner bearing properly.
- / 04. Install the dowel pins and a new gasket and then install the water pump
- / 05. Tighten the bolts
 - * When installing the water pump assembly, aligning the groove on the water pump shaft with tab on the oil pump shaft.

4-9-12. Water pump/impeller installation (Fig. 4-174)

- / 01. Only replace a new seal washer
- / 02. Install the impeller onto the water pump shaft.
 - * Torque:1.0~1.4 kgf-m
- / 03. The impeller has left hand threads.
- / 04. Install the dowel pins and a new gasket.
- / 05. Install the water pump cover and tighten the bolts.
 - * Troque:0.8~1.2 kgf-m

4-9-13. Thermo-sensor removal and inspection (Fig. 4-183)

- / 01. Drain the coolant and disconnect the thermo-sensor wire.
- / 02. Remove the thermo-sensor from the thermostat.
- / 03. Hand thermo-sensor into a liquid burner and measure the resistance through the sensor

Temperature(°C)	50	80	100	120
Resistance(Ω)	154	52	27	16



4-9-14. Thermo-sensor installation (Fig. 4-184)

- / 01. Apply bond (quick gasket) to thermo-sensor threads, install it into the thermostat housing
 - / 02. Connect the thermo-sensor wire.
 - / 03. Fill the radiator with coolant.
- * Be sure to bleed air from the cooling system.

4-9-15. Thermostat removal (Fig. 4-185, 4-186, 4-187, 4-188)

- / 01. Drain the coolant and disconnect the thermo-sensor wire from the thermostat.
- / 02. Disconnect the water hose from the thermostat housing.
- / 03. Disconnect the air vent tube from the thermostat housing.
- / 04. Remove the mounting bolt and the thermostat housing from the cylinder head.
- / 05. Remove the screws and separate the thermostat housing halves.
- / 06. Remove the thermostat from the thermostat housing.

4-9-16. Thermostat inspection

- / 01. hand the thermostat in a liquid burner and raise the water temperature to check its operation.

* Technical Data

Begins to open	72±2°C
Full-open	90°C
Valve lift	3.5~4.5 mm

- / 02. Do not let the thermostat touch the burner surface.
- / 03. Replace the thermostat if the valve stays open at room temperature.
- / 04. Test the thermostat after it is opened for about 5 minutes and holds the temperature at 70°C.

4-9-17. Thermostat installation (Fig. 4-186)

- / 01. The installation sequence is the reverse of removal.
- / 02. Replace the O-ring with a new one and apply grease to it.
- / 03. Fill the cooling system with the specified coolant.

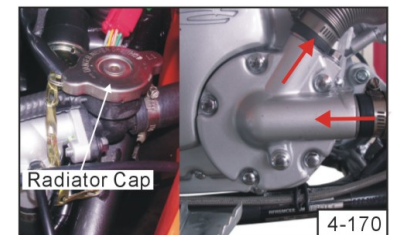
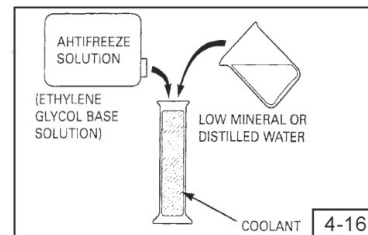
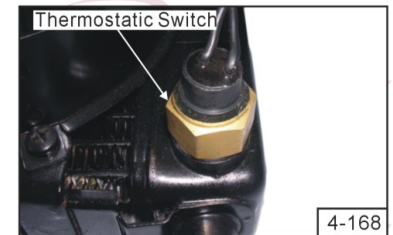
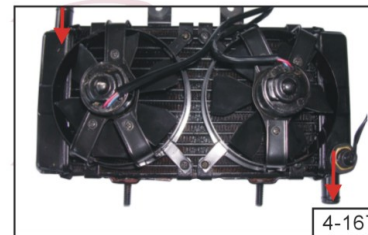
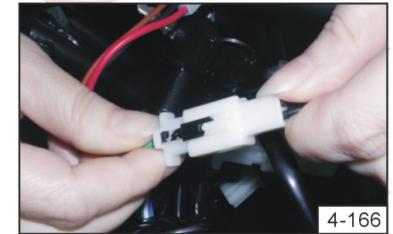
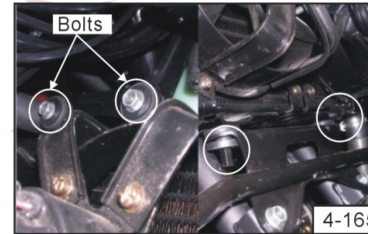
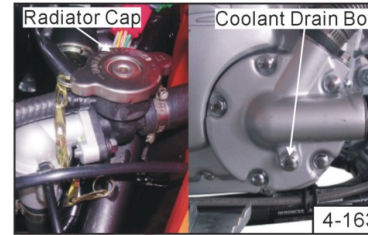
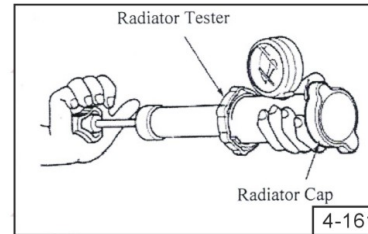

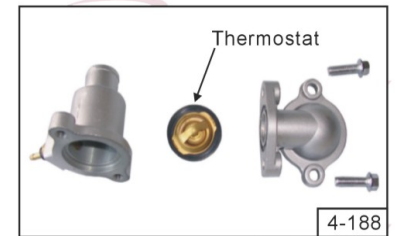
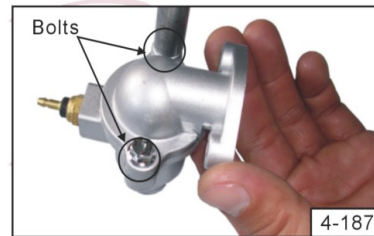
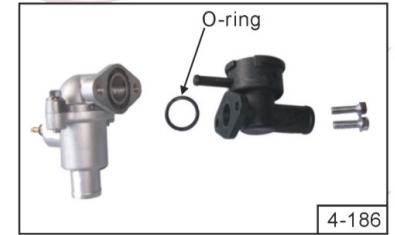
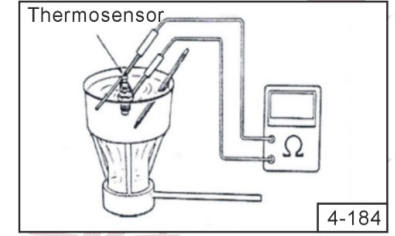
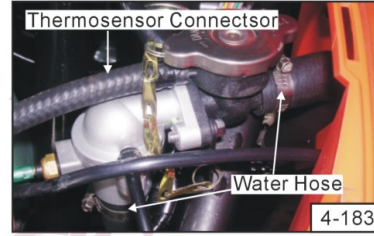
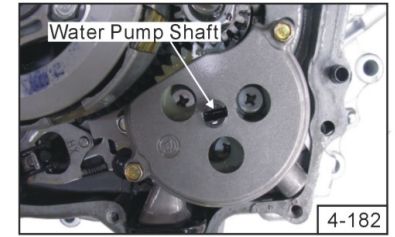
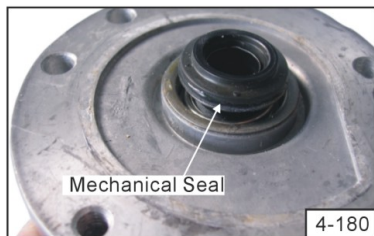
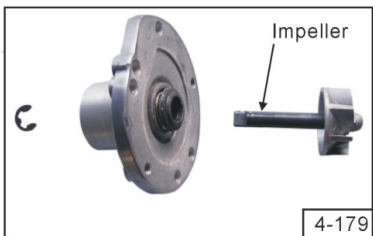
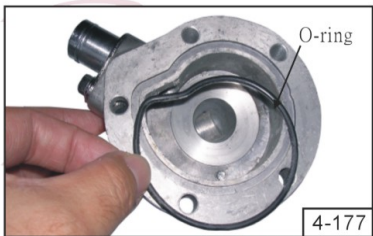
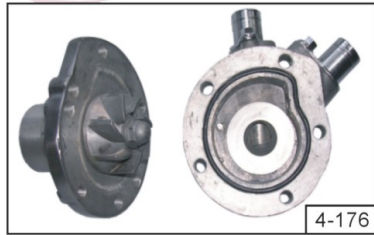
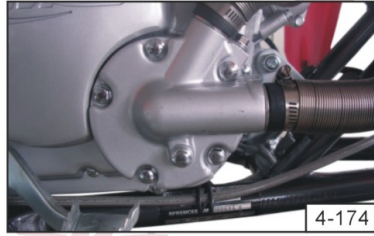
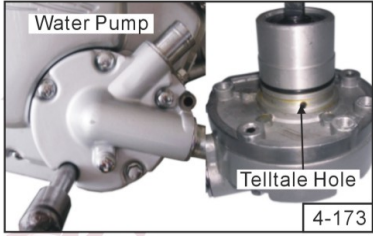
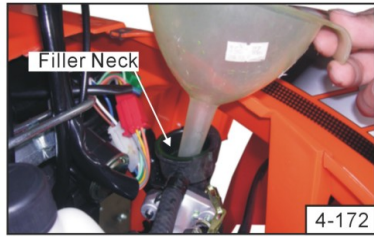
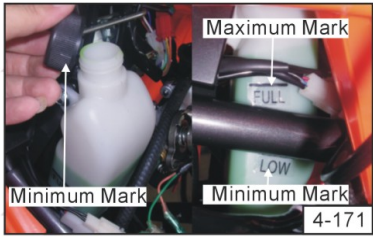



PART 4-a. CVT ENGINE DETAILS

4-01. CVT Fuel System and Carburetion

- /NOTE: Service information
- /NOTE: Problems shooting <Q-A>
- /01. Throttle valve disassembly
- /02. Throttle valve assembly
- /03. Carburetor removal
- /04. Carburetor disassembly
- /05. Carburetor cleaning and float valve inspection
- /06. Fuel reservoir o-ring inspection
- /07. Fuel float valve and reservoir assembly
- /08. Float level inspection
- /09. Carburetor installation

4-02. CVT Lubrication System

- /NOTE: Service information
- /NOTE: Problems shooting <Q-A>
- /01. Oil pump removal
- /02. Oil pump disassembly and inspection
- /03. Oil pump assembly
- /04. Installation

4-03. CVT Engine Removal/Installation

- /NOTE: Service information
- /01. Engine removal
- /02. Engine installation

4-04. CVT Cylinder Head/Valves

- /NOTE: Service information
- /NOTE: Problems shooting <Q-A>
- /01. Cylinder head cover removal and installation
- /02. Camshaft holder removal
- /03. Camshaft holder disassembly
- /04. Camshaft holder inspection
- /05. Camshaft holder assembly and inspection
- /06. Camshaft installation
- /07. Cylinder removal
- /08. Cylinder head disassembly
- /09. Valve/valve guide inspection
- /10. Cylinder head inspection
- /11. Valve spring inspection
- /12. Assembly
- /13. Installation



4-05. CVT Cylinder/Piston

- /NOTE: Service information
- /NOTE: Problems shooting <Q-A>
- /01. Cylinder/piston removal
- /02. Inspection
- /03. Cylinder inspection
- /04. Cylinder inspection
- /05. Piston ring installation
- /06. Piston installation
- /07. Cylinder installation

4-06. CVT Clutch/Gearshift Linkage

- /NOTE: Service information
- /NOTE: Problems shooting <Q-A>
- /01. Left crankcase cover removal
- /02. Inspection and installation
- /03. Drive pulley removal
- /04. Drive pulley disassembly and inspection
- /05. Drive pulley assembly
- /06. Installation
- /07. Clutch driven pulley removal
- /08. Drive belt inspection
- /09. Clutch outer inspection
- /10. Clutch/Drive pulley disassembly
- /11. Inspection
- /12. Driven pulley face bearing replacement
- /13. Clutch disassembly
- /14. Clutch driven pulley assembly
- /15. Installation

4-07. CVT Final Reduction and Transmission

- /NOTE: service information
- /NOTE: problems shooting <Q-A>
- /01. Transmission case cover removal
- /02. Transmission case cover disassembly
- /03. Assembly
- /04. Transmission removal
- /05. Main axles disassembly
- /06. Primary drive axles removal
- /07. Installation



4-08. CVT Crankcase/Crankshaft/Balance Shaft

- / NOTE: service information
- / NOTE: problems shooting <Q-A>
- / 01. Crankcase/Crankshaft/Balance Shaft removal
- / 02. Crankshaft inspection
- / 03. Crankcase/balancer installation

4-09. CVT Water Cooling System

- / NOTE: service information
- / NOTE: problems shooting <Q-A>
- / 01. Radiator cap inspection
- / 02. Radiator inspection
- / 03. Radiator removal
- / 04. Radiator disassembly
- / 05. Thermostatic switch
- / 06. Radiator assembly and installation
- / 07. Water pump mechanical seal inspection
- / 08. Water pump/impeller removal
- / 09. Water pump shaft removal
- / 10. Mechanical seal replacement
- / 11. Water pump shaft installation
- / 12. Water pump/impeller installation
- / 13. Thermo-sensor removal and inspection
- / 14. Thermo-sensor installation
- / 15. Thermostat removal
- / 16. Thermostat inspection
- / 17. Thermostat installation



<4-1. CVT Fuel System and Carburetion>

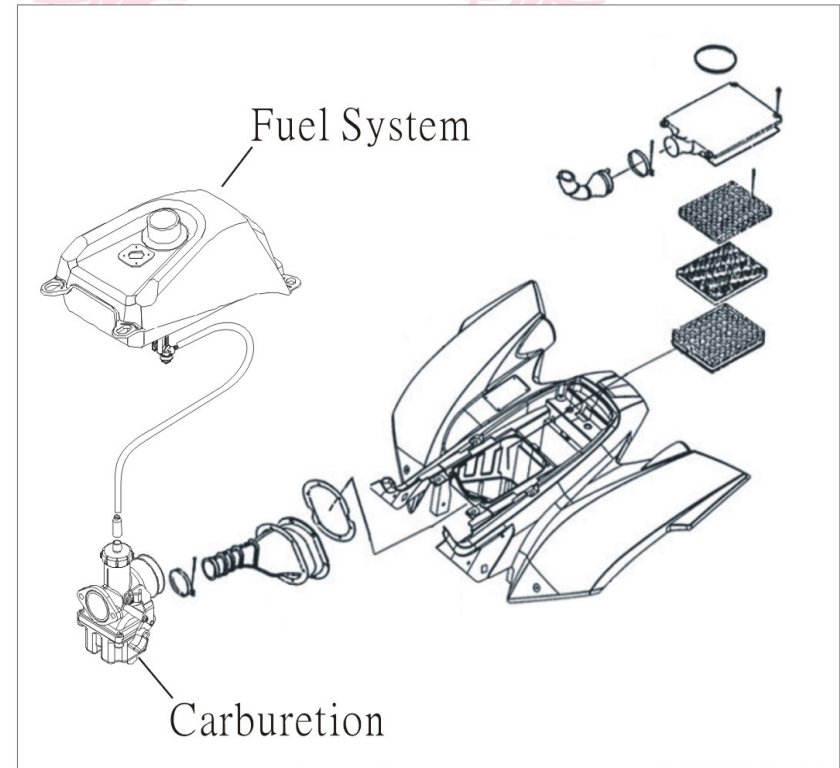



4-1. CVT Fuel System and Carburetion

- NOTE: Service Information

Maker(brand)	: Keihin	Keihin	Walbro
Type	: PTG-17	PTG-17	PZ 30B12
number install	: 1(single)	1(single)	1(single)
Engine	: LV 250	LV 300	LV 300

Carburetor Float level	: 12,5mm		31,5mm
Main jet	: #98	#102	#108
Slow jet	: #35	#35	# 38
Idle speed	: LV 250/300	1500 +/- 300 rpm	
Throttle grip free play	: LV 250/300	1-4mm	
Air screw opening	: LV 250/300	on 1 1/8 +/- 1/2	

- NOTE: Due to different area regulation, 3 kinds of carburetor could be installed on each vehicle.

<! WARNING 1> Gasoline is very dangerous. Be sure to keep sparks and flames away from working area.

AWARENESS(1): Gasoline is poisonous. People could be injured.

SOLUTION(1):

1. If people should swamp some gasoline or inhale a lot of gasoline vapor, or gasoline in eyes, go to doctor immediately.
2. If gasoline spills on skin, wash with soap and water. If gasoline spills on clothing, be changed clothes.

<! WARNING 2> POTENTIAL HAZARD: Improper care when refuelling.

AWARENESS(2): Fuel can spill, which can cause a fire and severe injury. Fuel expands when it heats up. If fuel tank is overfilled, fuel could spill out due to heat from the engine or the sun.

SOLUTION(2):

1. Do not overfill the fuel tank.
2. Do not spill fuel, especially on the engine or exhaust pipe.
3. Wipe up any spilled fuel. Be sure to close fuel tank cap.
4. Do not refuel right after the engine has been running.

- Caution:

1. Do not bend or twist control cables. Damaged control cables will not operate smoothly.
2. When disassembling fuel system parts, note the locations of O-rings. Replace them with new ones during reassembly.
3. Before float chamber disassembly, loosen the drain screw to drain the residual gasoline into a clean container.
4. After the carburetor is removed, plug the intake manifold side with a clean shop towel to prevent foreign matters from entering.



5. When cleaning the carburetor air and fuel jets, the O-rings and diaphragm must be removed first to avoid damage. Then, clean with compressed air.

6. When the motorcycle is not used for over one month, drain the residual gasoline from the float chamber to avoid erratic idling and clogged slow jet due to deteriorated fuel.

- NOTE: Problems Shooting

<Q-A> Lean mixture?

- . clogged carburetor fuel jets
- . float level too low
- . intake air leak
- . faulty charcoal canister
- . restricted fuel line

<Q-A> Engine Cranks but do not start?

- . no fuel in the tank
- . no fuel in the carburetor
- . cylinder flooded with fuel, no spark at plug
- . clogged air cleaner, intake air leak, . improper throttle operation

<Q-A> Engine idles roughly, stalls or runs poorly?

- . excessively used choke
- . ignition malfunction
- . faulty carburetor
- . poor quality fuel
- . lean or rich mixture
- . clogged air cleaner
- . incorrect idle speed
- . faulty charcoal canister

<Q-A> Engine lacks power?

- . clogged air cleaner
- . faulty carburetor
- . faulty ignition system

<Q-A> Rich mixture?

- . float level too low
- . clogged air jets
- . clogged air cleaner
- . worn throttle needle

<Q-A> Misfiring during acceleration?

- . faulty ignition system
- . faulty carburetor
- . faulty accelerating pump
- . faulty charcoal canister



<Q-A> Backfiring?

- . carburetor fuel level too low
- . improperly adjusted carburetor
- . faulty exhaust pipe

- CAUTION:

1. before disassembling carburetor, must drain screw to drain residual gasoline out.
2. The carburetor jets (air, ..) must cleaned with compressed air.

4-1-01. Throttle valve disassembly (Fig. CVT 4-01, 4-02, 4-03)

- / 01. Remove the fuel tank and the carburetor cap.
- / 02. Pull out the throttle valve.
- / 03. Compress the spring to disconnect the throttle cable by hand.
- / 04. Remove the spring from the throttle valve.
- / 05. Pry off the needle retainer and remove the jet needle.
- / 06. Check the throttle valve and jet needle for wear or damage.

4-1-02. Throttle valve assembly (Fig. CVT 4-04, 4-05)

- / 01. Reverse the "DISASSEMBLY" procedures.
- / 02. Install the throttle valve into the carburetor body.
 - * Align the groove in the throttle valve with the throttle stop screw on the carburetor body.

4-1-03. Carburetor removal (Fig. CVT 4-06, 4-07, 4-08)

- / 01. Remove the fuel tank and carburetor cap.
- / 02. Loosen the drain screw to drain the gasoline from the float chamber from the float chamber.
 - * Keep sparks and flames away from the work area and drain gasoline on a clean container.
- / 03. Loosen the screw on the lock plate for disconnect the choke cable.
- / 04. Remove the two bolts at the air cleaner case.
- / 05. Loosen the air cleaner connecting tube band screw.
- / 06. Remove the two carburetor lock nuts attaching the inlet pipe.
- / 07. Remove the carburetor.

4-1-04. Carburetor disassembly (Fig. CVT 4-09, 10, 11, 12, 13, 14, 15)

- / 01. Remove the float chamber attaching three screws and remove the float chamber.
- / 02. Remove the jet holder.
- / 03. Pull out the float pin, then remove float and float valve.
- / 04. Remove the main jet, needle jet holder, and needle jet.
- / 05. Remove the slow jet.
- / 05. Remove the air screw and throttle stop screw.
 - * Be careful not to damage the jets and jet holder when removing them.
 - * Before removal, turn the throttle stop screw and air screw in and count the number of turns until they seat lightly and then make a note of this.
 - * Do not force the screw against it seat to avoid seat damage.
 - * Be sure to install the O-ring in the reverse order of removal.
- / 06. Remove the two screws and the air cut-off valve cover.
- / 07. Remove the springs, diaphragm and O-rings.
- / 08. Inspect the diaphragm and spring for wear or damage.



4-1-5. Carburetor cleaning and float valve inspection (Fig. CVT 4-16, 4-17)

- / 01. Blow compressed air through all passages of the carburetor body.
- / 02. Inspect the float valve seat for wear or damage.
- / 03. Inspect the float for damage or fuel level inside the float chamber.

4-1-6. Fuel reservoir o-ring inspection (Fig. CVT 4-18)

- / 01. Remove the O-ring.
- / 02. Inspect the check the O-ring for damage.
- / 03. Replace with new ones if necessary.

4-1-7. Fuel float valve and reservoir assembly (Fig. CVT 4-19)

- / 01. Install the slow jet.
- / 02. Install the needle jet, needle jet holder and main jet.
- / 03. Install the throttle stop screw and air screw
- / 04. Install the spring, diaphragm and O-rings.
 - * When installing the air screw, return it to the original position as note during removal.
 - After the carburetor is installed, be sure to perform the exhaust emission test.
- / 05. Install the float valve, float and float pin.

4-1-8. Float level inspection (Fig. CVT 4-20)

- / 01. Turn the carburetor upside down so that the float will go down to make the float valve contact the float valve seat.
- / 02. Then slowly tilt the carburetor and measure the float level with the float level gauge while the float pin just contacts with float valve.
 - * Float level: 14.8mm
- / 03. When adjusting, carefully bend the float pin.
- / 04. Check the float for proper operation.
- / 05. Install the jet holder, aligning the jet holder groove with the carburetor tab and then install the float chamber.

4-1-9. Carburetor installation

Reverse the "CARBURETOR REMOVAL" procedures.

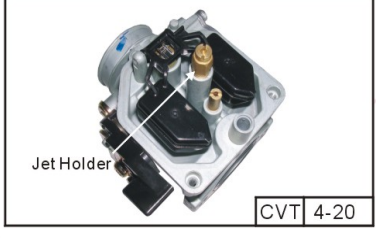
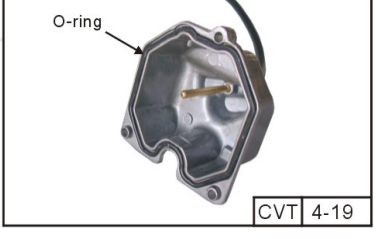
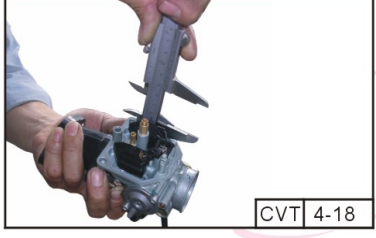
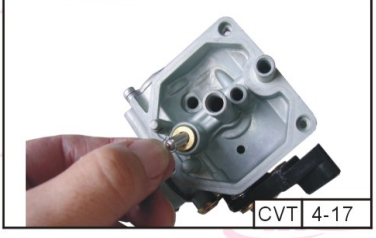
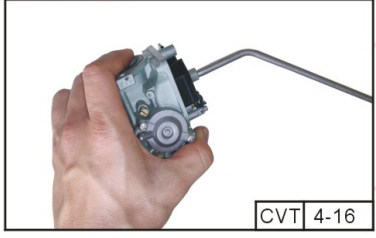
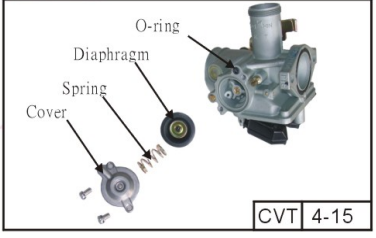
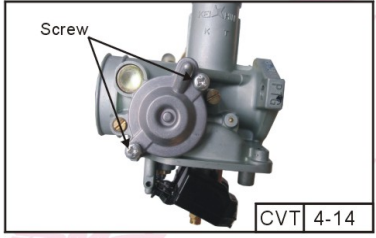
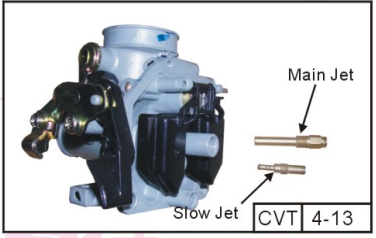
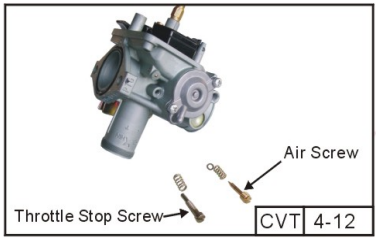
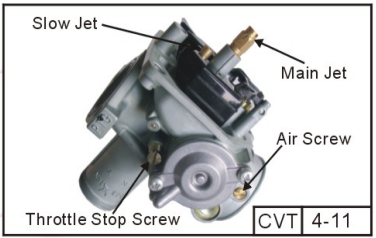
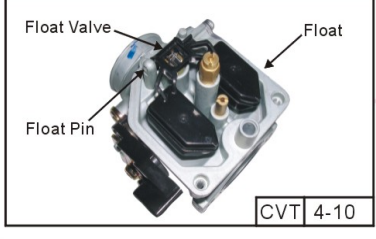
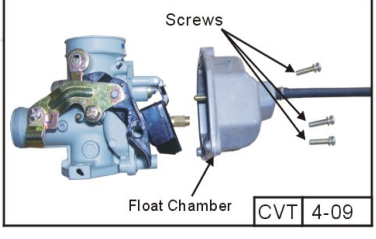
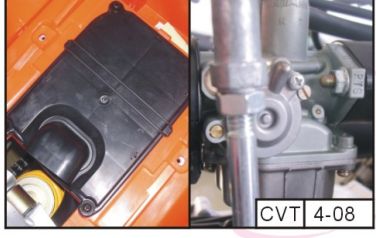
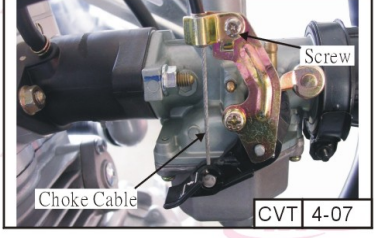
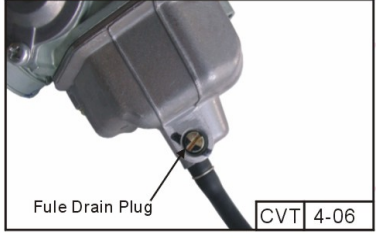
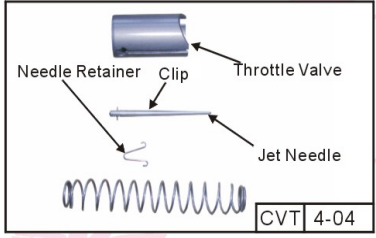
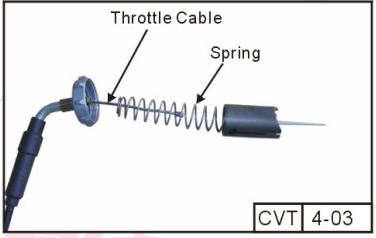
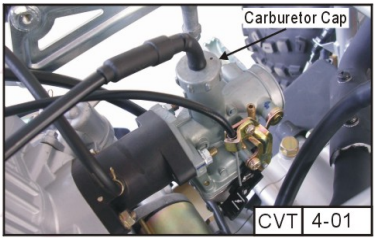



<4-2. CVT Lubrication System >

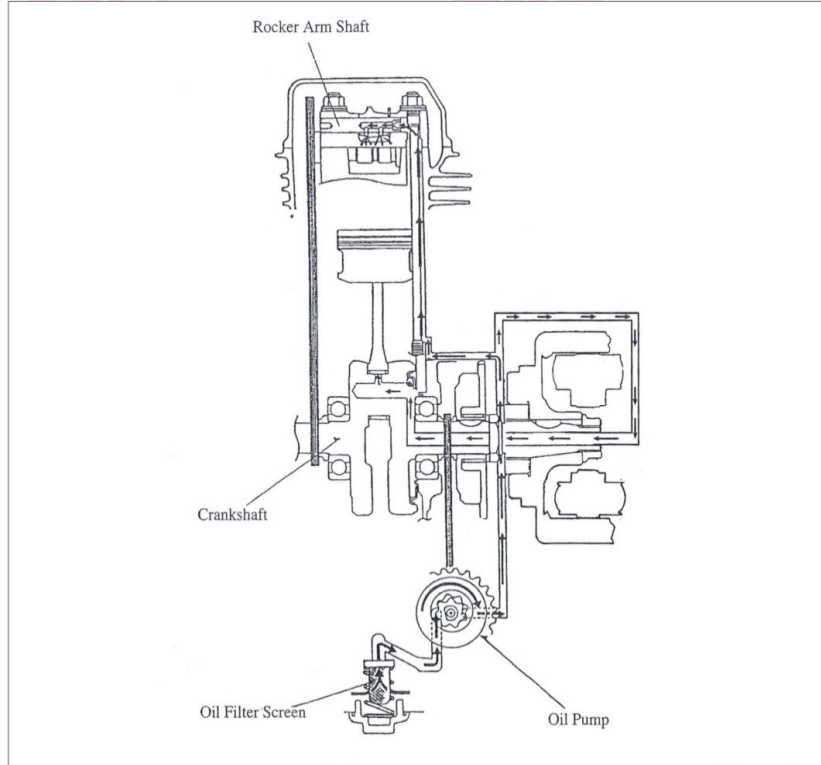

4-2. CVT Lubrication System

- NOTE: Service Information

01. Engine oil capacity (water-cooled)

at draining : 1.4 liter
at disassembly : 1.6 liter

02. Recommended engine oil: a qualified synthetic 4-stroke oil or equivalent motor oil

03. API service classification SF or SG Viscosity: SAE 10W-40

04. Oil pump rotor	: Standard(mm/in)	Service Limited(mm/in)
/ tip clearance	: 0.15 (0.006)	0.20(0.008)
/ body clearance	: 0.15-0.21(0.006-0.008)	0.25(0.010)
/ side clearance	: 0.05-0.13(0.002-0.005)	0.14(0.006)

05. Torque Value

/ Oil drain bolt : 25N-m (2.5 kgf-m, 18 lbf-ft)
/ Oil mounting screw : 10N-m (1.0 kgf-m, 7 lbf-ft)

- CAUTION: Used or incorrect engine oil may cause skin cancer if repeatedly left in contact with the skin for prolonged periods.

- CAUTION: The maintenance of lubrication system can be performed with the engine installed in the frame. Use care when removing and installing the oil pump not to allow dust and foreign matters to enter the engine and oil line. Do not attempt to disassemble the oil pump. The oil pump must be replaced as a set when it reaches its service limit. After the oil pump is installed, check each part for oil leaks.

- NOTE: Problems shooting:

<Q-A> Engine oil level too low-high oil consumption?

- . External oil leaks
- . Worn position rings
- . Oil not changed often enough
- . Faulty head gasket

<Q-A> Engine oil contamination?

- . Oil not changed often
- . Head gasket faulty
- . Worn piston rings

4-2-1. Oil pump removal (Fig. CVT 4-21, 4-22, 4-23, 4-24)

- / 01. Remove the right crankcase cover and the a/c generator flywheel.
- / 02. Remove the starter clutch gear.
- / 03. Remove the two bolts and oil separator cover.



/ 04. Pry the circlip off and remove the oil pump driven gear then remove the oil pump drive chain and oil driven sprocket.

/ 05. Remove the two oil pump bolts for remove the oil pump.

4-2-2. Oil pump disassembly and inspection (Fig. CVT 4-25, 4-26, 4-27, 4-28)

/ 01. Remove the screw and disassemble the oil pump.

/ 02. Measure the rotor end-to-pump body clearance.

* Service limit: 0.12mm

/ 03. Measure the inner rotor-to-outer rotor clearance.

* Service limit: 0.2mm

/ 04. Measure the pump body-to-outer rotor clearance.

* Service limit: 0.25mm

4-2-3. Oil pump assembly (Fig. CVT 4-29)

/ 01. Install the outer rotor, inner rotor and pump shaft into the pump body.

* Insert the pump shaft by aligning the flat on the shaft with the flat in the inner rotor

/ 02. Install the dowel pin.

/ 03. Install the pump cover by aligning the hole in the cover with the dowel pin.

/ 04. Tighten the screw to secure the pump cover.

4-2-4. Installation (Fig. CVT 4-21, 4-22, 4-24)

/ 01. Reverse the "OIL PUMP REMOVAL" Procedures.

* Install the oil pump with the arrow on the pump body facing up and fill the oil pump with engine oil before installation

/ 02. Make sure that the pump shaft rotates freely without binding.

/ 03. Install oil pump driven sprocket and drive chain, circlip and oil separator cover.

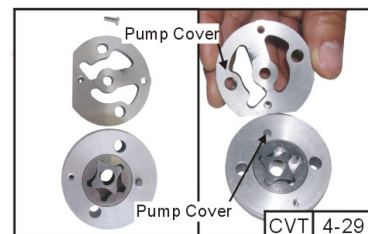
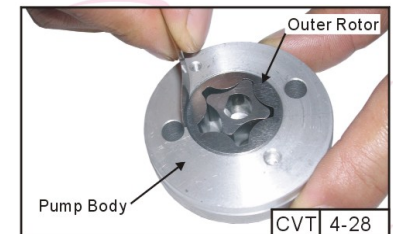
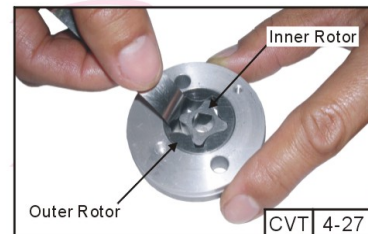
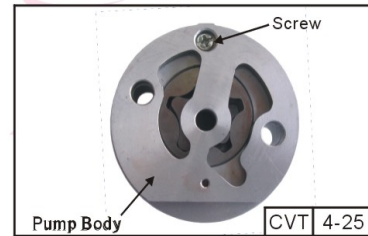
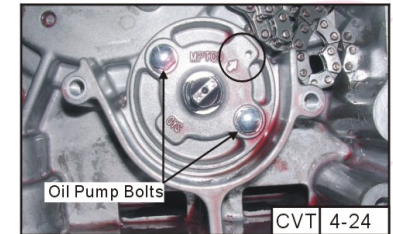
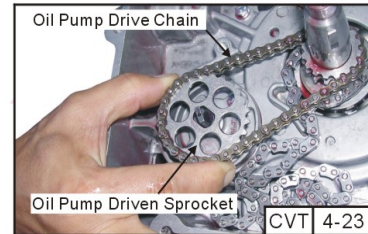
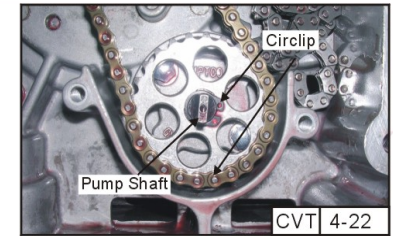
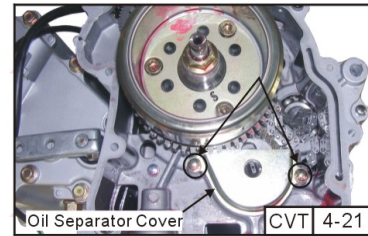



4-3. CVT Engine Removal/Installation

- NOTE: Service Information:

01. Engine oil capacity (water cooled)
 at draining : 1.4 liter
 at disassembly : 1.6 liter
02. Engine weight : 49.1kg (108 lbs)
03. Torque Values
 / Exhaust pipe joint nut : 14 N.m (1.4 kgf.m, 10 lbf.ft)
 / Engine rear mounting nut : 40 N.m (4.0 kgf.m, 29 lbf.ft)
 / Engine front mounting nut : 40 N.m (4.0 kgf.m, 29 lbf.ft)
 / Drive sprocket bolt : 12 N.m (1.2 kgf.m, 09 lbf.ft)

4-3-1. Engine removal (refer to Fig. 4-30, 31, 32, 33, 34, 35, 36, 37, 38)

- / 01. Support the vehicle using a safety stand or a lift
- / 02. Turn the ignition switch OFF and disconnect the battery negative (-) wire from the terminal.
- / 03. Drain the engine oil and transmission oil out.
- / 04. Remove the following items:
 - Carburetor
 - Exhaust system
- / 05. Disconnect the oil recycle tube at the cylinder head cover.
- / 06. Disconnect the water hose from water pump cover.
- / 07. Remove the bolt at the thermostat and disconnect the thermo sensor wire, then disconnect the thermostat from the cylinder head.
- / 08. Remove the bolt at the drive select arm, then disconnect the drive select arm from engine assembly.
- / 09. Disconnect the speedometer cable (Road Legal model only)
- / 10. Remove the three bolts at the drive sprocket cover and then remove the drive sprocket cover.
- / 11. Remove the two bolts on the drive sprocket.
- / 12. Remove the drive sprocket and washer.
- / 13. Remove the starter motor wire nut for disconnect the starter motor wire.
- / 14. Remove the bolt at the starter motor for disconnect the ground wire lead.
- / 15. Remove the A.C. Generator, purser and gear change switch couplers.
- / 16. Disconnect the spark plug cap.
- / 17. Remove the three bolts and remove the outlet hose cover.
- / 18. Unscrew the clamp and then disconnect the outlet hose from the left crankcase cover.
- / 19. Unscrew the clamp and then disconnect the inlet hose from the left crankcase cover.



- / 20. Remove the two bolts at the left foot peg attaching the left floor board holder and remove the nut at the left floor board holder, then remove the left floor board holder.
- / 21. Remove the two bolts at the right foot peg attaching the right floor board holder.
- / 22. Remove the nut at the right floor board holder and bolt attaching the reservoir protection cover, then remove the right floor board holder.
- / 23. Remove the two nuts and then remove the drive select lever.
 Remove the two bolts at the left front fender holder for remove the left front fender holder.
- / 24. Remove the rear lower mounting bolt and nut.
- / 25. Remove the rear upper mounting bolt and nut.
- / 26. Remove the front mounting bolts and nuts.
- / 27. Remove the four bolts for remove the left and right engine brackets.
- / 28. Remove the engine assembly to the left side of the machine.

4-3-2. Engine installation

- / 01. Reverse the "Engine removal" procedures.

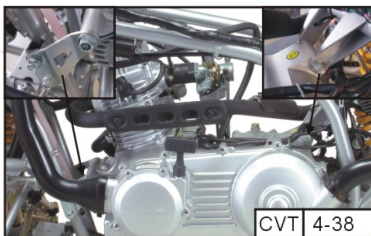
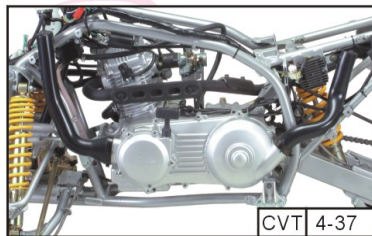
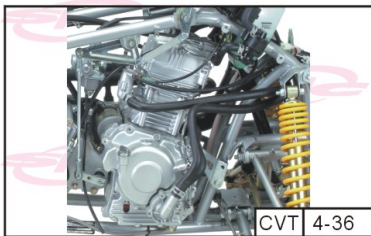
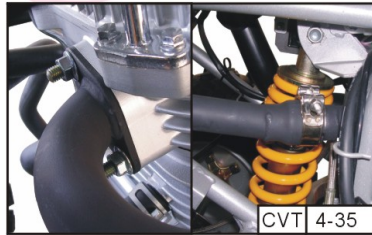
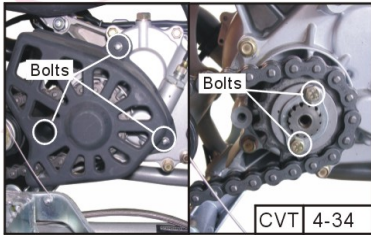
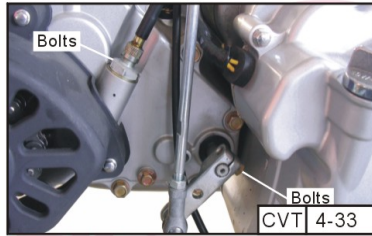
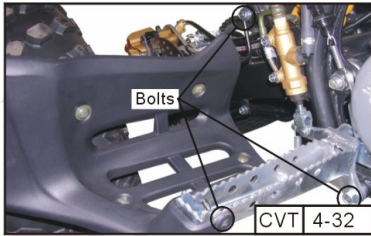
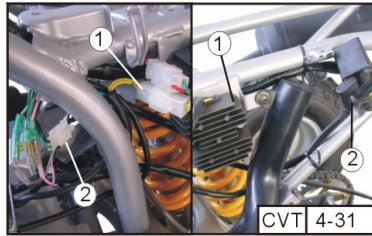
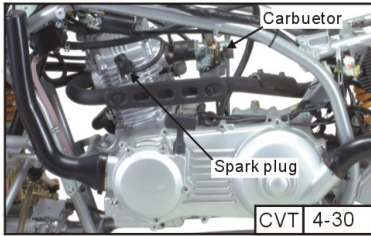

<4-4. CVT Cylinder Head/Valves >

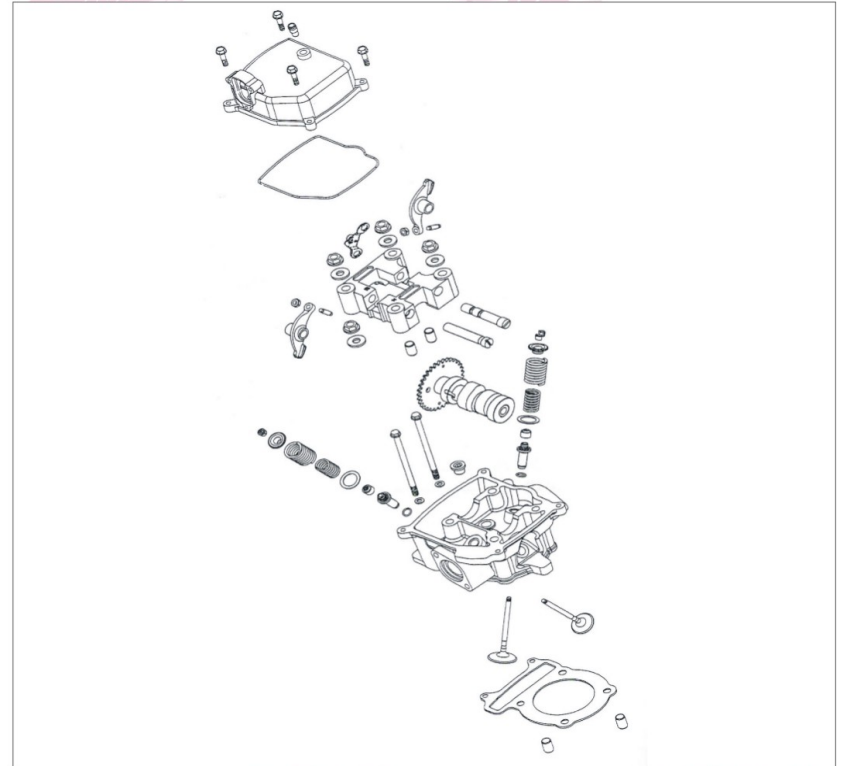



4-4. CVT Cylinder Head/Valves

- NOTE:: Service Information

Item		Standard (mm)	Service Limit (mm)
Valve clearance (cold)	IN	0.1	---
	EX	0.1	---
Cylinder head compression pressure		15±2kg/cm ²	
Cylinder head warpage		---	0.05
Camshaft cam height	IN	34.287	34.15
	EX	34.1721	34.05
Valve rocker arm to shaft clearance		0.034-0.09	0.1
Valve stem-to-guide clearance	IN	0.010-0.037	0.06
	EX	0.025-0.052	0.08
Valve spring free length	IN	30.9	29.4
	EX	41	---
Valve spring compressed force	IN	10.21-11.84kg(at 18.05mm)	---
	EX	19.14-22.02kg(at 21.5mm)	---
Valve spring tilt	IN	0.8	---
	EX	1.07	---

- Caution:

1. The cylinder head can be serviced with the engine installed in the frame.
2. When assembling, apply molybdenum disulfide grease or engine oil to the valve guide movable parts, valve arm and camshaft sliding surfaces for initial lubrication.
3. The camshaft is lubricated by engine oil through the cylinder head engine oil passages. Clean and unclog the oil passages before assembling the cylinder head.
4. After disassembly, clean the removed parts and dry them with compressed air before inspection.
5. After removal, mark and arrange the removed parts in order. When assembling, install them in the reverse order of removal.

- Torque Valve:

- Cylinder head cover bolt: 0.8-1.2 kgf-m
 Cam shaft bold nut: 2.3-2.7 kgf-m
 Tappet adjusting nut: 0.7-1.1 kgf-m

NOTE: Problems Shooting

1. Engine top-end problems usually affect engine performance. These problem can be diagnosed by a compression test or by tracing engine noises to the top-end with a sounding rod stethoscope.
2. If the performance is poor at low speeds, check for white smoke in the crankcase breather tube. If the tube is smoky, check for a seized piston ring.



<Q-A> Low compression from valve?

- . Incorrect valve adjustment
- . Burned or bent valve
- . Incorrect valve timing
- . Weak valve spring

<Q-A> Low compression from cylinder head?

- . Leaking or damaged head gasket
- . Warped or cracked cylinder head

<Q-A> Low compression?

- . from worn cylinder, piston or piston rings

<Q-A> High compression?

- . Excessive carbon build-up on piston crown or on combustion chamber

<Q-A> Unreasonable smoke?

- . Worn valve stem or valve guide
- . Damaged stem seal
- . Worn cylinder, piston or piston rings

<Q-A> Unreasonable noise?

- . Incorrect valve adjustment
- . Sticking valve or broken valve spring
- . worn rocker arm and/or shaft

<Q-A> Rough idle?

- . Low cylinder compression
- . Intake air leak

<Q-A> Overheating

- . Excessive carbon build-up on the piston head or combustion chamber

<Q-A> Knocking or abnormal noise

- . Excessive carbon build-up
- . worn piston and cylinder

4-4-1. Cylinder head cover removal and installation (Fig. CVT 4-39, 4-40)

- / 01. Remove fuel tank, disconnect oil recycle tube
- / 02. Remove bolt and cylinder head cover
- / 03. Install the new cylinder head cover o-ring (Fig. CVT 4-41)
- / 04. Tighten cylinder head bolt
* Torque: 0.8-1.2 kgf-m

5-4-2. Camshaft holder removal (Fig. CVT 4-42, 4-43)

- / 01. Remove cylinder head cover and cam chain tension cap bolt, and O-ring
- / 02. Tighten the cam chain tension screw clockwise



- / 03. Remove the four camshaft holder nuts and washers (Fig. CVT 4-44)
- / 04. Remove the camshaft holder and dowel pins.
- / 05. Remove the camshaft gear from the cam chain and remove the camshaft (Fig. CVT 4-45)

4-4-3. Camshaft holder disassembly (Fig. CVT 4-46)

- / 01. Take out the valve rocker arm shafts.
- / 02. Remove the valve rocker arms, arm shafts and stop plate.

4-4-4. Camshaft holder inspection (Fig. CVT 4-47, 4-48, 4-49)

- / 01. Inspect the camshaft holder for wear or damage.
- / 02. Inspect the rocker arm shaft for blue discoloration or grooves
- / 03. If any defects are found, replace the rocker arm shaft with a new one, then inspect lubrication system.
- / 04. Inspect the rocker arm bore lobe contact surface and adjuster surface for wear, pitting, scratches, or blue discoloration.
- / 05. If any defects are found, replace the rocker arm shaft with a new one, then inspect lubrication system.
- / 06. Measure each rocker arm shaft O.D.
- / 07. Measure the I.D. of each valve rocker arm.
- / 08. Measure arm to shaft clearance.
- / 09. Replace as a set if out of specification.
 - * Service limits: 0.10mm

4-4-5. Camshaft holder assembly and inspection (Fig. CVT 4-50, 4-51)

- / 01. Reverse the "CAMSHAFT HOLDER DISASSEMBLY" procedures.
 - * Use bolt of camshaft holder to align the cross cutout on the exhaust valve rocker arm shaft
- / 02. Check each camshaft bearing for play or damage.
- / 03. Replace the new camshaft set if the bearings are noisy or have excessive play.
- / 04. Inspect camshaft lobes for pitting/scratches/blue discoloration.
- / 05. Measure the cam lobe height.
 - * Service Limits:
 - IN : 34.15mm replace if below.
 - EX : 34.05mm replace if below.
- / 06. Any defects are found, replace the new camshaft. Then, inspect lubrication system.

4-4-6. Camshaft installation (Fig. CVT 4-44, 4-45)

- / 01. Reverse the "CAMSHAFT REMOVAL" procedures.
- Note the following points:

(1st. step). Turn the flywheel to "T" mark on the flywheel aligns with the index mark on the crankcase. Keep the round hole on the camshaft facing up and align the punch marks on the camshaft gear with the cylinder head surface (Position the intake and exhaust cam lobes down.) and install the camshaft onto the cylinder head. Install the camshaft dowel pins and holder.

* Apply engine oil to the threads of the cylinder head nuts. Diagonally tighten the cylinder head nuts in 2-3 times.

* Torque: Cam shaft hold nut: 2.3-2.7 kgf-m



(2nd. step). Turn the cam chain tension screw counter-clockwise to release it. Counter-clockwise to release it. Apply engine oil to a new O-ring and install it. Tighten the cam chain tension cap bolt.

* Be sure to install the O-ring into the groove properly

(3rd. step). Adjust the valve clearance.

4-4-7. Cylinder removal (Fig. CVT 4-52, 4-53)

- / 01. Remove the camshaft
- / 02. Remove the carburetor
- / 03. Remove the exhaust muffler.
- / 04. Remove the two bolts and then remove the carburetor intake manifold.
- / 05. Remove the bolt and disconnect the thermostat.
- / 06. Remove the two cylinder head bolts.
- / 07. Remove the cylinder head.

4-4-8. Cylinder head disassembly (Fig. CVT 4-54)

- / 01. Remove the valve spring cotters, retainers, springs, spring seats, oil seals and valves using a valve spring compressor.
 - * Be sure compress the valve springs with a valve spring compressor. Mark all disassembled parts to ensure correct reassembly.

4-4-9. Valve/valve guide inspection (Fig. CVT 4-55)

- / 01. Inspect each valve for bending, burning.
- / 02. Scratches or abnormal stem wear.
- / 03. If any defects are found, replace the valve with a new one.
- / 04. Check valve movement in the guide.
- / 05. Measure each valve stem O.D.
- / 06. Measure each valve guide I.D.
- / 07. Subtract each valve stem O.D. from the stem-to guide clearance.
 - * Service limits: IN : 0.06mm replace if over
 - EX: 0.08mm replace if over
- * If the stem-to-guide clearance exceeds the service limits, replace the cylinder head as necessary.

4-4-10. Cylinder head inspection (Fig. CVT 4-56)

- / 01. Check the spark plug hole and valve areas for cracks.
- / 02. Check the cylinder head for warp age with a straight edge and feeler gauge.
 - * Service limit: 0.05mm repair or replace if over.

4-4-11. Valve spring inspection (Fig. CVT 4-57, 4-58, 4-59)

- / 01. Measure the free length of the inner and outer valve springs.
 - * Service limit:
 - Inner: 29.4mm replace if below.
 - Outer: 39mm replace if below.
- / 02. Measure compressed force (valve spring) and installed length.
- / 03. Replace if out of specification.



* Service limits :

IN : 10.20-11.84kg (at 18.05mm)

EX: 19.14-22.02kg (at 21.5mm)

/ 04. Measure the spring tilt. Replace if out of specification.

* Service limits:

IN: 0.8mm

EX: 1.07mm

4-4-12. Assembly (Fig. CVT 4-54)

/ 01. Install the valve spring seats and oil seal.

* Be sure to install new oil seal

/ 02. Lubricate each valve with engine oil and insert the valves into the valve guides.

/ 03. Install the valve springs and retainers.

/ 04. Compress the valve springs using the valve spring compressor, then install the valve cotters.

* when assembling, a valve spring compressor must be used. Install the cotters with the pointed ends facing down from the upper side of the cylinder head.

/ 05. Tap the valve stems gently with a plastic hammer for 2-3 times to firmly seat the cotters.

* Be careful not to damage the valves.

4-4-13. Installation (Fig. CVT 4-60)

/ 01. Install the dowel pins and a new cylinder head gasket.

/ 02. Reverse the "CYLINDER HEAD REMOVAL" procedures.

* Torque: Cylinder head bolt: 1.0 kgf-m

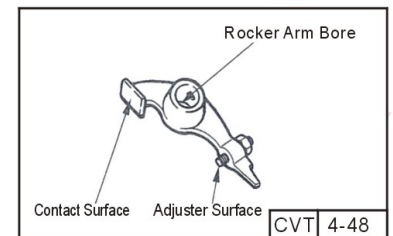
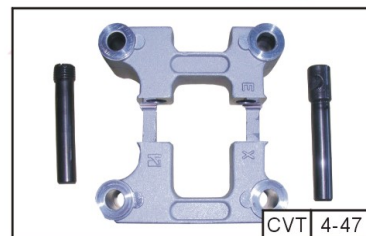
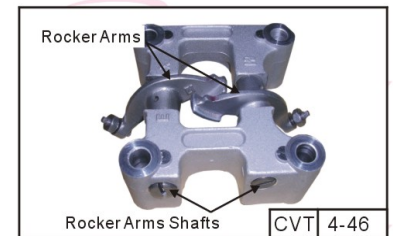
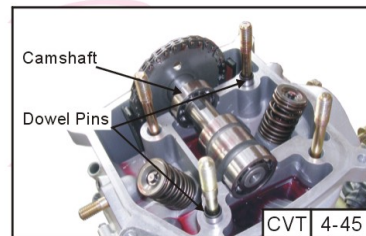
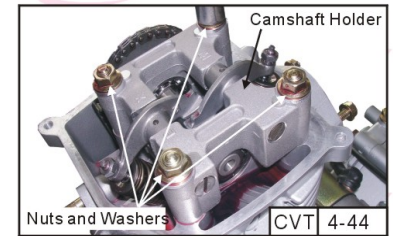
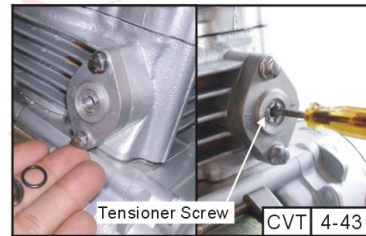
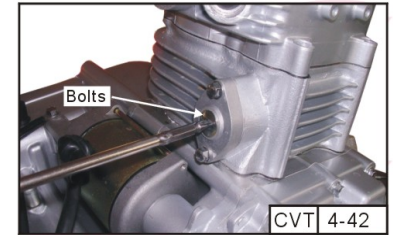
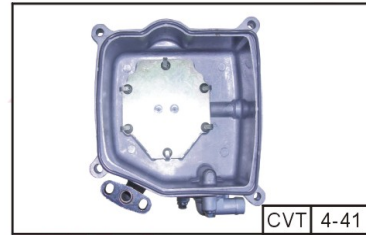
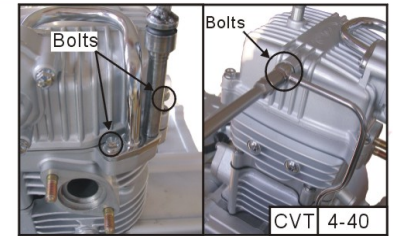
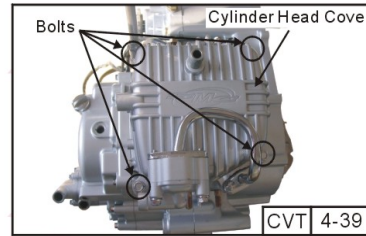

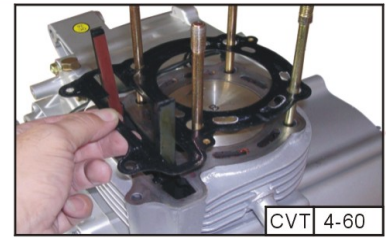
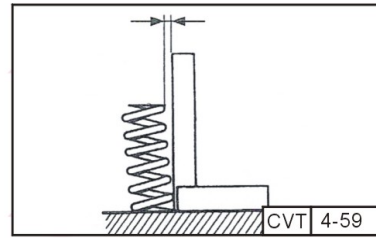
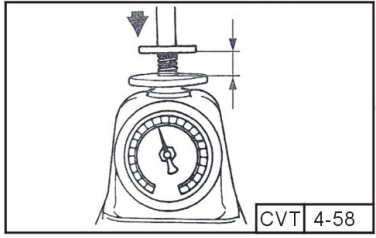
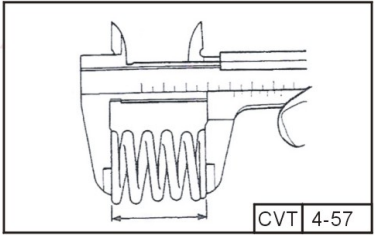
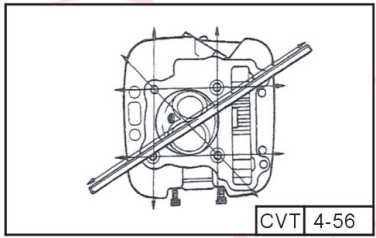
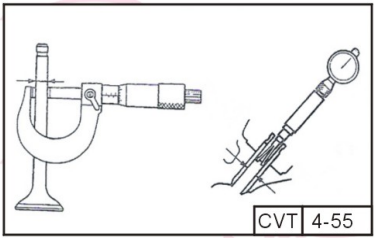
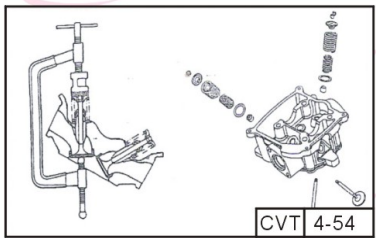
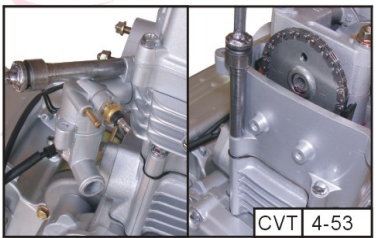
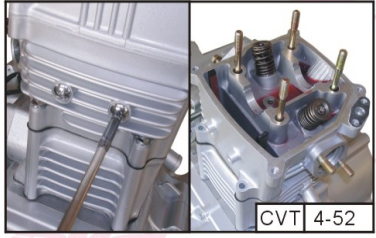
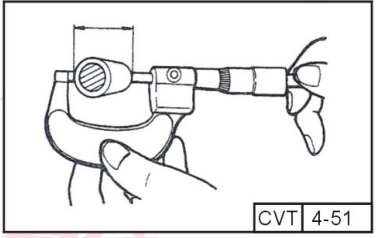
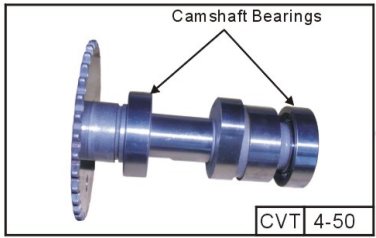
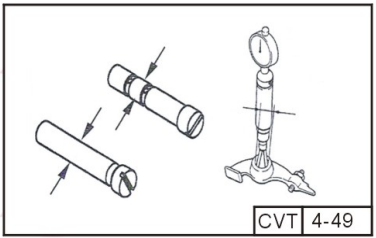



<4-5 CVT Cylinder/Piston >



4-5. CVT Cylinder/Piston

- NOTE: Service Information

		Standard (mm)	Service Limit(mm)
Cylinder	I.D	72.705~72.715	72.8
	Warpage	---	0.05
	Cylindricity	---	0.05
	True roundness	---	0.05
Piston, piston ring	Ring-to-groove clearance	Top	0.015~0.055
		Second	0.015~0.055
	Ring end gap	Top	0.15~0.3
		Second	0.3~0.45
		Oil ring	0.2~0.7
	Piston O.D.	72.67~72.69	72.6
	Piston O.D. measuring position	10mm from bottom of skirt	---
Piston-to-cylinder clearance	0.010~0.040	0.1	
Piston pin hole I.D.	17.002~17.008	17.04	
Piston pin O.D.		16.994~17.000	16.96
Piston-to-piston pin clearance		0.002~0.014	0.02
Connecting rod small end I.D. bore		17.016~17.034	17.06

- Caution:

1. Cylinder head lubricating oil is fed through an oil passage in the cylinder. Be sure this oil passage is not clogged and that the O-rings and dowel pins are in place before installation.
2. When disassembling, mark and store the disassembled parts to ensure they are reinstalled in their original locations.
3. Clean all disassembled parts with cleaning solvent and dry them by blowing them off with compressed air before inspection.
4. The cylinder/piston can be serviced without remove the engine out of frame. After disassembly, be sure to clean the removed parts and dry them with compressed air before inspection.

NOTE: Problem shooting

<Q-A> Low compression? Worn cylinder or piston rings

<Q-A> Excessive smoke?

- . Worn cylinder, piston or piston rings
- . Improper installation of piston rings
- . Scored or scratched piston of cylinder wall

<Q-A> Overheating?

- . Excessive carbon build-up on the piston head or combustion chamber



<Q-A> Knocking or abnormal noise?

- Worn piston and cylinder
- Excessive carbon build-up

4-5-1. Cylinder/piston removal (Fig. CVT 5-61, 5-62, 5-63, 5-64)

- / 01. Remove the cylinder head.
- / 02. Remove the two dowel pins, cylinder head gasket and cam chain guide.
- / 03. Unscrew the clamp and disconnect the water hose.
- / 04. Remove the cylinder.
- / 05. Remove the cylinder gasket and dowel pins.
- / 06. Clean any gasket material from the cylinder surface.
 - * Be careful not to drop foreign matters into the crankcase.
- / 07. Remove the piston pin clip.
 - * Place a clean towel in the crankcase to keep the piston pin clip from falling into crankcase
- / 08. Press the piston pin out of the piston and remove the piston.

4-5-2. Inspection (Fig. CVT 5-65, 5-66, 5-67, 5-68, 5-69, 5-70)

- / 01. Inspect the piston, piston pin and piston rings.
- / 02. Remove the piston rings.
 - * Take care not to damage or break the piston rings during removal
- / 03. Clean carbon deposits from the piston ring grooves.
- / 04. Inspect the piston wall for wear/scratches/damage.
- / 05. If any defects are found, replace the piston with a new one.
- / 06. Install the piston rings onto the piston and measure the piston ring-to-groove clearance.
 - * Service Limits: Top: 0.09mm replace if over
 - 2nd: 0.09mm replace if over

- / 07. Remove the piston rings and insert each piston ring into the cylinder bottom.
- / 08. Use the piston head to push each piston ring into the cylinder.
 - * Use the piston head to push each piston ring into the cylinder.
- / 09. Measure the piston ring end gap.
 - * Service Limit:
 - Top: 0.5mm replace if over
 - 2nd: 0.65mm replace if over Oil ring: 0.9mm replace if over

- / 10. Measure the piston pin hole I.D.
 - * Service Limit: 17.04mm replace if over
- / 11. Measure the piston pin O.D.
 - * Service limit: 16.96mm replace if below.
- / 12. Measure the piston O.D.
 - * Take measurement at 10mm from the bottom and 90° to the piston pin hole.
 - * Service limit: 72.6mm replace if below.
- / 13. Measure the piston-to-piston pin clearance.
 - * Service limit: 0.02mm replace if over.

4-5-3. Cylinder inspection (Fig. CVT 5-71)

- / 01. Inspect the cylinder bore for wear or damage.
- / 02. Measure the cylinder I.D. at three level of top, middle and bottom at 90° to the piston pin (in



both X and Y directions).

- * Cylinder I.D. : Service limit: 72.8mm replace if over.
- / 03. Measure the cylinder-to-piston clearance.
 - * Service limit: 0.1mm repair or replace if over.
- / 04. The true roundness is the difference between the values measured in X and Y directions. The cylindricity (difference between the values measured at the three levels) is subject to the maximum value calculated.
 - * Service limits:
 - True roundness: 0.05mm repair or replace if over.
 - Cylindricity: 0.05mm repair or replace if over.

4-5-4. Piston ring installation (Fig. CVT 5-72, 5-73, 5-74)

- / 01. Install the piston rings onto the piston .
- / 02. Apply engine oil to each piston ring.
 - * Be careful not to damage or break the piston and piston rings.
 - * All rings should be installed with the markings facing up.
 - * After installing the rings, they should rotate freely without sticking
- / 03. Measure the connecting rod small end I.D.
 - * Service limit : 17.06mm replace if over.
- / 04. Measure the connecting rod to piston pin clearance.
 - * Service limit: 0.06mm replace if over.
- / 05. Inspect the exhaust side and intake side chain guides.
 - * Wear/Damage -- replace new one.

4-5-5. Piston installation (Fig. CVT 5-75)

- / 01. Remove any gasket material from the crankcase surface.
 - * Be careful not to drop foreign matters into the crankcase.
- / 02. Install the piston, piston pin and a new piston pin clip.
 - * Position the piston "IN" mark on the intake valve side.
 - * Place a clean shop towel in the crankcase to keep the piston pin clip from falling into the crankcase

4-5-6. Cylinder installation

- / 01. Install the dowel pins and a new cylinder gasket on the crankcase.
- / 02. Coat the cylinder bore, piston and piston rings with clean with clean engine oil.
- / 03. Caution to lower the cylinder over the piston by compressing the piston rings.
 - * Apply proper clean engine oil around cylinder wall.
 - * Be careful not to damage or break the piston rings.
- / 04. Stagger the ring end gaps at 120° to the piston pin.

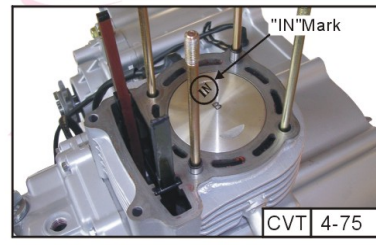
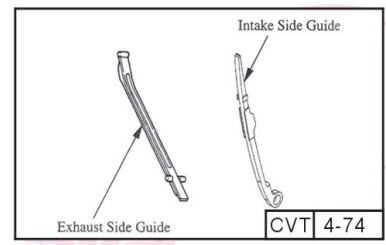
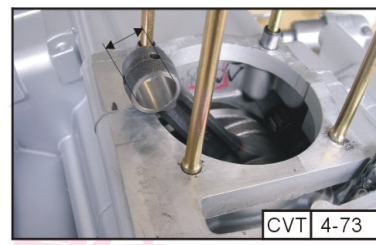
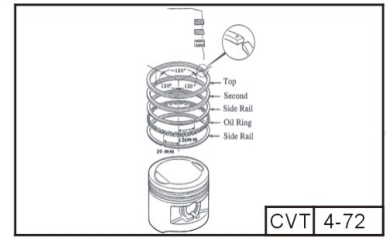
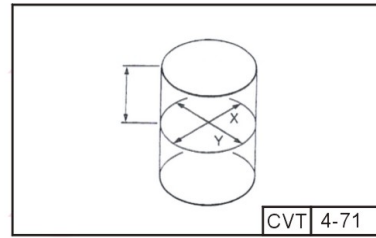
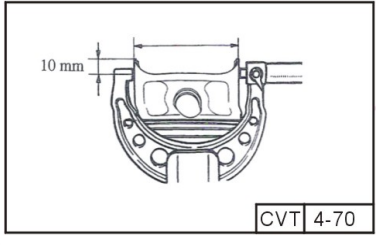
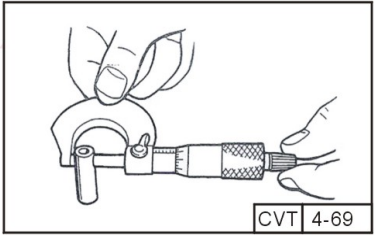
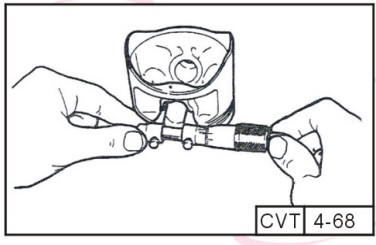
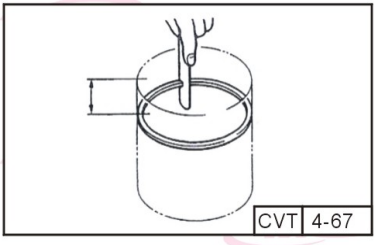
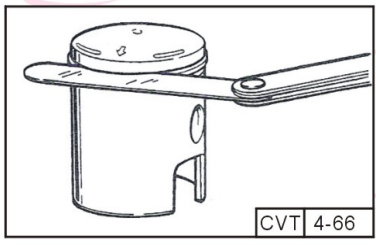
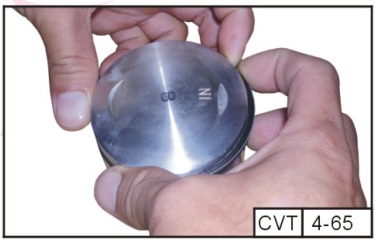
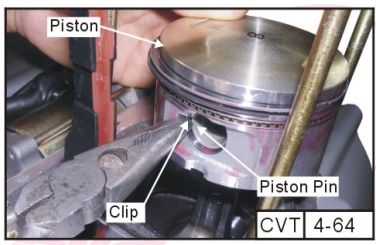
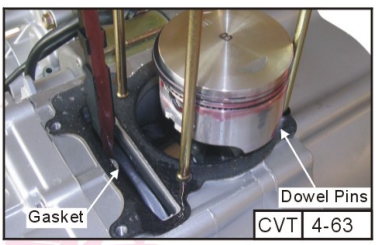
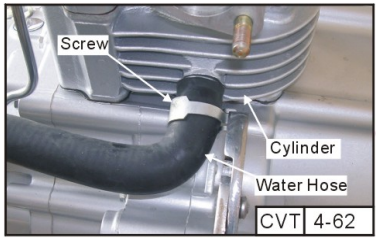
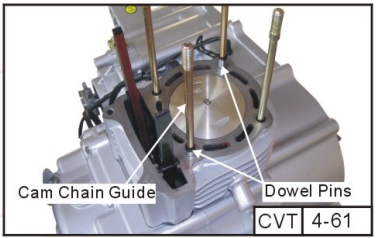



<S-6 CVT Clutch/Gearshift Linkage>

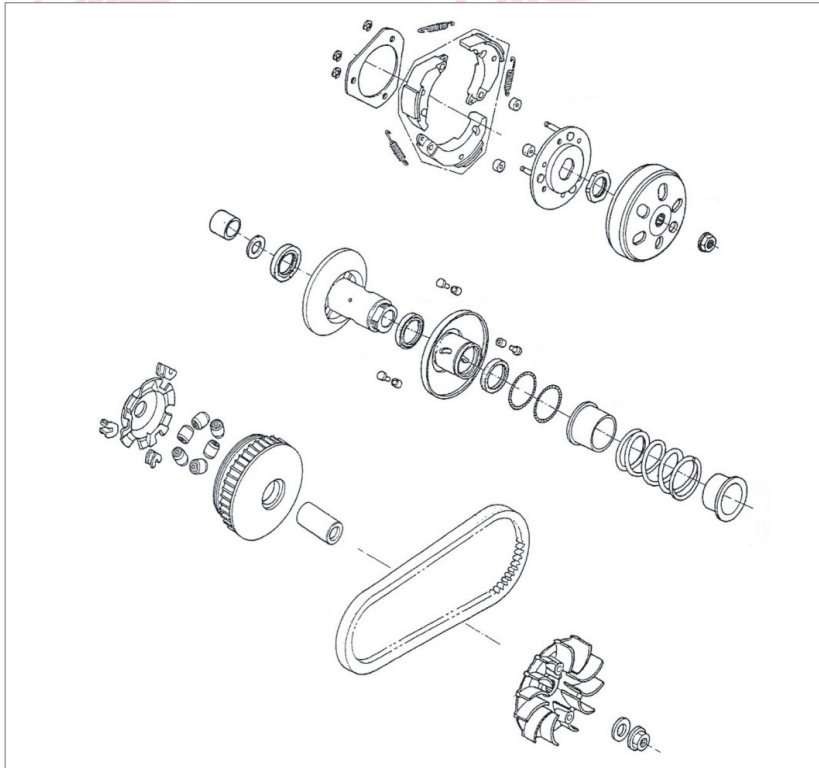

4-6. CVT Clutch/Gearshift Linkage

- NOTE: Service Information

Item	Standard (mm)	Service limit (mm)
Movable drive face bushing I.D.	26.989-27.052	27.06
Drive face collar O.D.	26.96-26.974	26.94
Drive belt width	23.6-24.4	22
Clutch lining thickness	-----	0.5
Clutch outer I.D.	153.0-153.2	153.5
Driven face spring free length	-----	131
Driven face O.D.	39.965-39.985	39.94
Movable driven face I.D.	40.000-40.025	40.06
Weight roller O.D.	22.92-23.08	22.8

* Torque value:

Drive face nut 9.0-10.0kgf-m

Clutch outer nut 5.0-6.0kgf-m

Drive plat nut 5.0-6.0kgf-m

- Caution:

1. The drive pulley, clutch and driven pulley can be serviced with the engine installed in the frame.
2. Avoid getting grease and oil on the drive belt and pulley faces. Remove any oil or grease from them to minimize the slipping of drive belt and drive pulley.

Note:: Problems Shooting -- Faulty clutch operation can usually be corrected by adjusting the free play.

<Q-A> Engine starts but vehicle not move.

- . Worn drive belt
- . Broken ramp plate
- . Worn or damaged clutch lining
- . Broken driven face spring

<Q-A> Lack of power

- . Worn drive belt
- . Weak driven face spring
- . Worn weight roller
- . Fouled drive face

<Q-A> Engine stalls or motorcycle creeps

- . Broken clutch weight spring



4-6-1. Left crankcase cover removal (Fig. CVT 4-76, 4-77, 4-78, 4-79)

- / 01. Remove the five bolts.
- / 02. Remove the starting cover.
- / 03. Remove the dowel pins and gasket.
- / 04. Remove the three bolts.
- / 05. Remove the outlet hose cover.
- / 06. Loosen the drive belt air inlet and outlet hose band screws and disconnect them from the left crankcase cover.
- / 07. Remove the left crankcase cover bolts and left crankcase cover.
- / 08. Remove the gasket and dowel pins.

4-6-2. Inspection and installation (Fig. CVT 4-80, 4-81)

- / 01. Inspect the bearing for allow play in the left crankcase cover or the bearing turns
 - * whenever roughly – replace.
- / 02. Install the dowel pins and new gasket.
- / 03. Reverse the “LEFT CRANKCASE COVER REMOVAL” procedures.
- / 04. Install the left crankcase cover and tighten the bolts.
- / 05. Connect the drive belt air inlet and outlet hose and tighten band screws.
- / 06. Install the starting cover and outlet hose cover.

4-6-3. Drive pulley removal (Fig. CVT 4-82, 4-83)

- / 01. Remove the left crankcase cover.
- / 02. Hold the drive pulley using a universal holder and remove the drive face nut and washer.
- / 03. Remove the drive pulley.
- / 04. Remove the movable drive face assembly and drive pulley collar.

4-6-4. Drive pulley disassembly and inspection (Fig. CVT 4-84, 4-85, 4-86, 4-87)

- / 01. Remove the ramp plate.
- / 02. Remove the six weight rollers.
- / 03. Check each weight roller for wear or damage.
- / 04. Measure each weight roller O.D.
 - * Service limit: 22.8mm replace if below.
- / 05. Measure the movable drive face bushing I.D.
 - * Service limit: 27.06mm replace if over.

4-6-5. Drive pulley assembly (Fig. CVT 4-87, 4-88)

- / 01. Install the weight rollers into the movable drive face.
- / 02. Install the ramp plate.
- / 03. Check the drive pulley collar for wear or damage.
- / 04. Measure the O.D. of the drive pulley collar sliding surface.
 - * Service limit: 26.94mm replace if below.

4-6-6. Installation (Fig. CVT 4-89, 4-90)

- / 01. Install the drive pulley face assembly and collar.
- / 02. Install the drive pulley, wash and nut.
 - * When installing the drive pulley face, compress it to let the drive belt move downward to the lowest position so that the drive pulley can be tightened.
- / 03. Install the washer with the “OUT SIDE” mark facing out.



* Do not get oil or grease on the drive belt or pulley faces.

* Torque: 9.0-10.0kgf-m

4-6-7. Clutch driven pulley removal (Fig. CVT 4-92, 4-93)

- / 01. Remove the left crankcase cover.
- / 02. Remove the drive pulley.
- / 03. Hold the clutch outer with the universal holder and remove the clutch outer nut.
- / 04. Remove the wash, collar and clutch outer.
- / 05. Remove the clutch/driven pulley and drive belt.

4-6-8. Drive belt inspection (Fig. CVT 4-94)

- / 01. Check the drive belt for cracks, separation or abnormal or excessive wear.
- / 02. Measure the drive belt width.
 - * Service limit: 22.0 mm replace if below.

4-6-9. Clutch outer inspection (Fig. CVT 4-95)

- / 01. Inspect the clutch outer for wear or damage.
- / 02. Measure the clutch outer I.D.
 - * Service limit: 153.5mm replace if over.

4-6-10. Clutch/Drive pulley disassembly (Fig. CVT 4-96, 97, 98, 99, 100)

- / 01. Hold the clutch/driven pulley assembly with the clutch spring compressor.
 - * Be sure to use a clutch spring compressor to avoid spring damage.
 - * Special tools: Clutch spring compressor and disassemble the clutch/driven pulley set
- / 02. Remove the seal collar.
- / 03. Pull out the guide roller pins and guide rollers.
- / 04. Remove the movable driven face from the driven face.
- / 05. Remove the oil seal from the movable driven face.
- / 06. Measure the clutch lining thickness.
 - * Service limit: 0.5mm replace if below.

4-6-11. Inspection (Fig. CVT 4-101, 4-102, 4-103)

- / 01. Measure the driven face spring free length.
 - * Service limit: 131mm replace if below.
- / 02. Check the driven face for wear or damage.
- / 03. Measure the driven face O.D.
 - * Service limit: 39.94mm replace if below.
- / 04. Check the movable driven face for wear or damage.
- / 05. Measure the movable driven face I.D.
 - * Service limit: 40.06mm replace if over.

4-6-12. Driven pulley face bearing replacement (Fig. CVT 4-104, 4-105)

- / 01. Drive the inner needle bearing out of the driven pulley face.
 - * Discard the removed bearing and replace with a new one
- / 02. Remove the snap ring and drive the outer bearing out of the driven face.
 - * Discard the removed bearing and replace with a new one.
- / 03. Apply grease to the outer bearing.



- / 04. Drive a new outer bearing into the driven face with the sealed end facing up.
- / 05. Seat the snap ring in its groove.
- / 06. Apply grease to the driven face bore areas.
 - * Pack all bearing cavities with proper grease.
 - * Specified grease: Heat resistance 230°C
- / 07. Press a new needle bearing into the driven face.

4-6-13. Clutch disassembly (Fig. CVT 4-100)

- / 01. Remove the circlips and retainer plate to disassemble the clutch.
 - * Keep grease off the clutch linings.

4-6-14. Clutch driven pulley assembly

- / 01. Install the damper rubbers on the drive plate pins.
- / 02. Install the clutch weights/shoes and clutch springs onto the drive plate.
- / 03. Install the retainer plate and secure with the circlips.
- / 04. Clean the driven pulley faces and remove any grease from them.
- / 05. Install the movable driven face onto the driven face.
- / 06. Apply grease to the guide rollers and guide roller pins and then install them onto the moveable driven face.
- / 07. Install the movable driven face onto the driven face.
- / 08. Apply grease to the guide rollers and guide roller pins and then install them into the holes of the driven face.
- / 09. Install the seal collar.
- / 10. Remove any excessive grease.
 - * Be sure to clean the driven face off any grease
- / 11. Set the driven pulley assembly, driven face spring and clutch assembly onto the clutch spring compressor.
 - * Align the flat surface of the driven face with the flat on the clutch drive plate.
- / 12. Compress the clutch spring compressor and install the drive plate nut.
- / 13. Put the clutch spring compressor in a vise and tighten to check the specified torque.
 - * Torque: 5.0-6.0kgf-m

4-6-15. Installation (Fig. CVT 4-91)

- / 01. Install the clutch/driven pulley and driven belt onto the drive shaft.
 - * Keep grease off the drive shaft
- / 02. Install the clutch outer, collar and washer.
- / 03. Hold the clutch outer with the flywheel holder.
- / 04. Install and tighten the clutch outer nut.
 - * Torque: 5.0-6.0kg-m

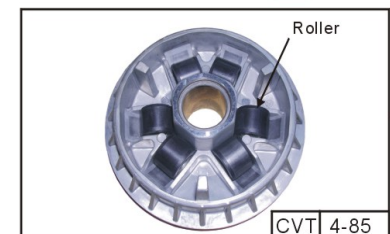
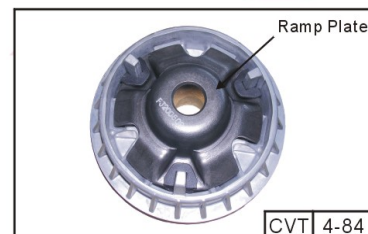
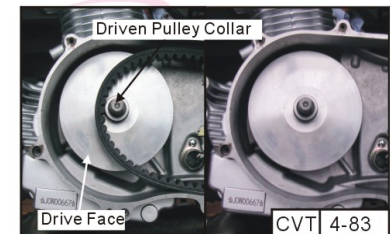
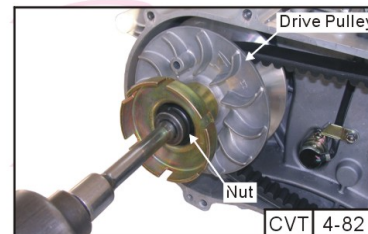
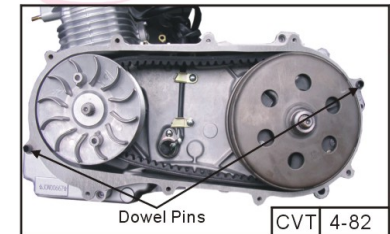
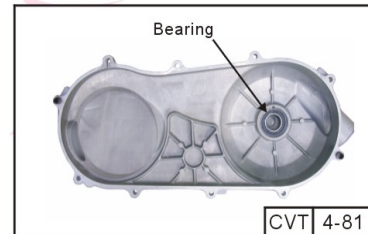
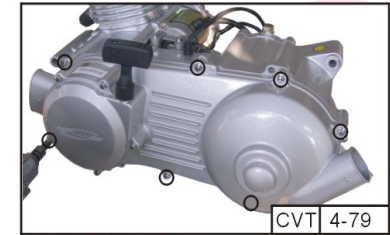
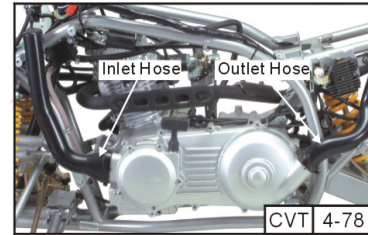
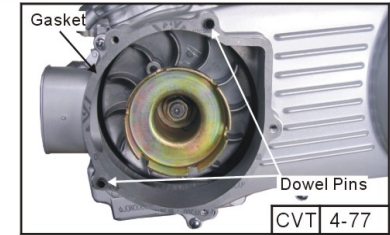
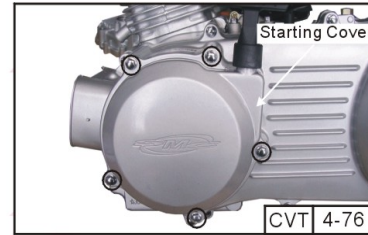

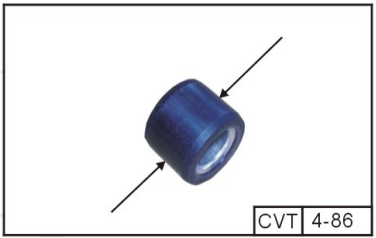

CVT 4-86

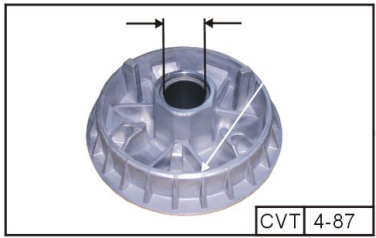

CVT 4-87

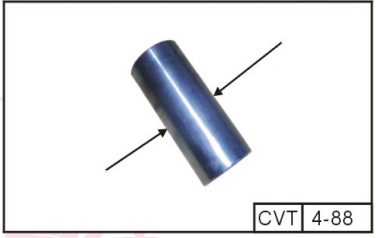

CVT 4-88

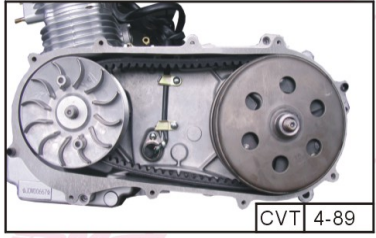

CVT 4-89

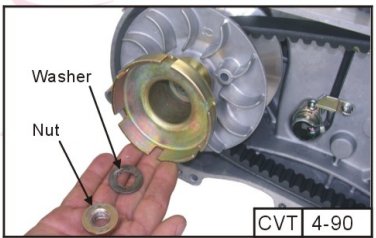

Washer
Nut

CVT 4-90

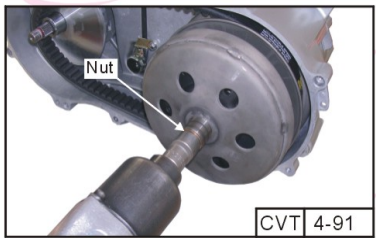

Nut

CVT 4-91

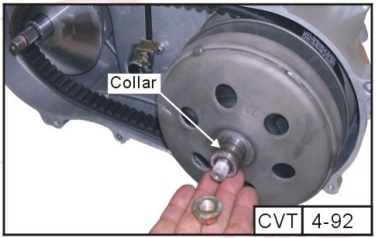

Collar

CVT 4-92

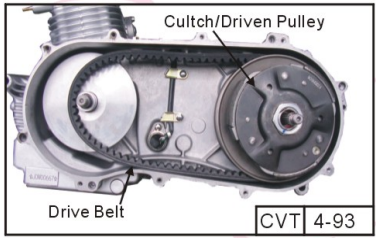

Clutch/Driven Pulley

Drive Belt

CVT 4-93

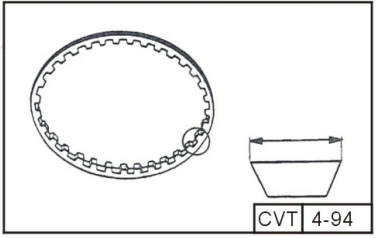

CVT 4-94



CVT 4-95



CVT 4-96

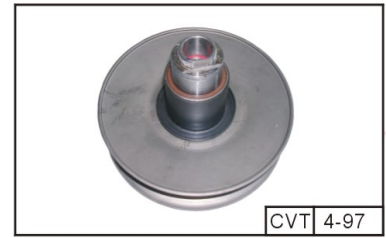

CVT 4-97

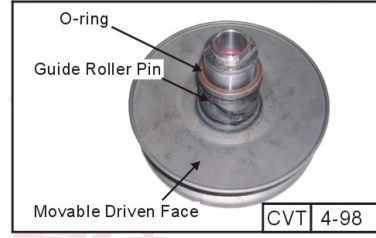

O-ring
Guide Roller Pin

Movable Driven Face

CVT 4-98

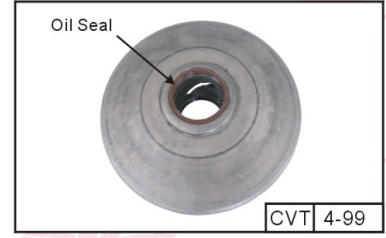

Oil Seal

CVT 4-99

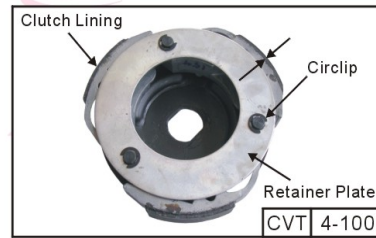

Clutch Lining

Circlip

Retainer Plate

CVT 4-100

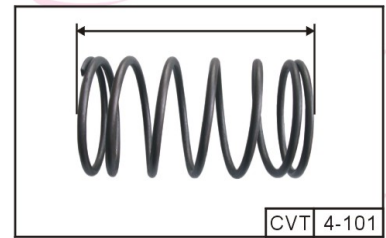

CVT 4-101



CVT 4-102

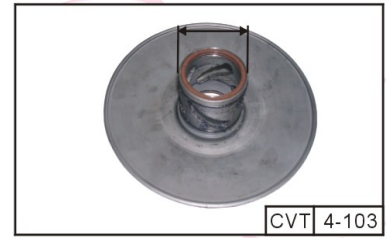

CVT 4-103

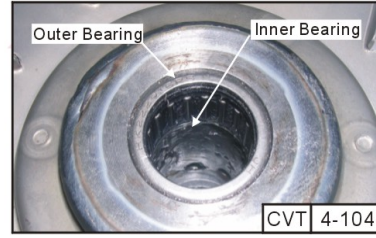

Outer Bearing

Inner Bearing

CVT 4-104

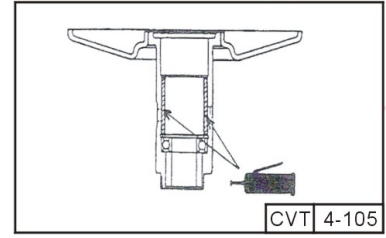

CVT 4-105



<4-7. CVT Final Reduction and Transmission>

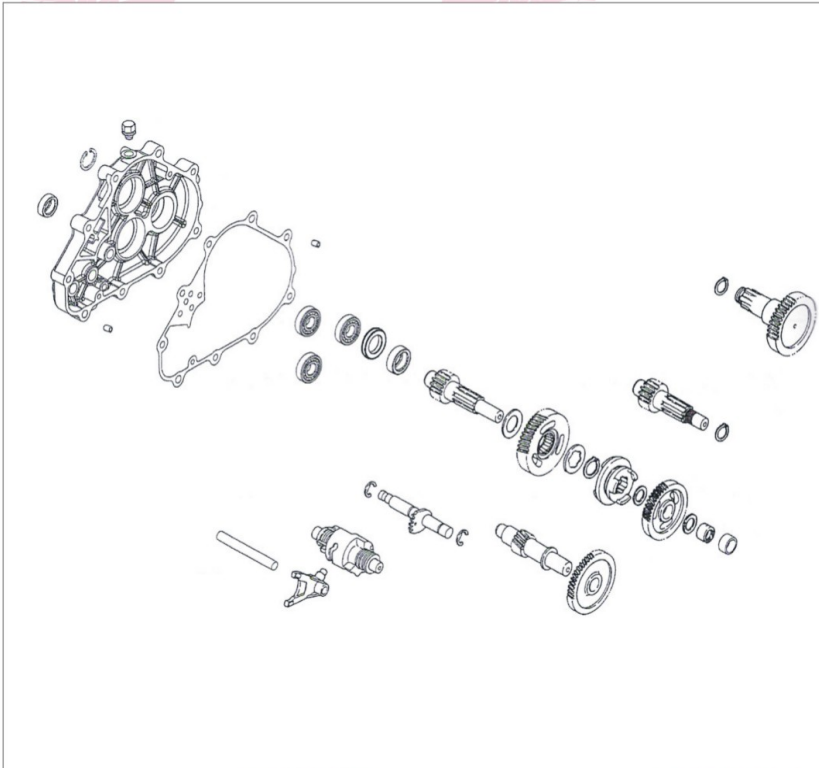

4-7. CVT Final Reduction and Transmission

- NOTE: Service Information

Specified Oil: GEAR OIL SAE 90#

Oil Capacity:

- At change :0.3 liter;

- At disassembly : 0.4 liter

Caution:

1. The transmission system can be serviced with the engine installed in the frame.

2. When replacing the drive shaft, use a special tool to hold the bearing inner race for this operation.

Torque value: Transmission case cover bolt 2.4~3.0kgf-m

Note: Problem Shooting

<Q-A> Engine starts but vehicle does not move?

- Damaged transmission
- Seized or burnt transmission

<Q-A> Oil leaks?

- Oil too rich
- Worn or damaged oil seal

<Q-A> Hard to shift?

- . Improper clutch operation
- . Incorrect clutch adjustment
- . Incorrect engine oil viscosity
- . Bent shift fork
- . Bent shift fork shaft
- . Bent shift fork claw
- . Damaged shift drum cam grooves
- . Bent shift spindle

4-7-1. Transmission case cover removal (Fig. CVT 4-106, 4-107, 4-108, 4-109, 4-110)

/ 01. Drain transmission gear oil into a clean container.

/ 02. Remove the three bolts and then remove the drive sprocket cover.

/ 03. Remove the two bolts and then remove the washer and drive sprocket.

/ 04. Remove the bolt and then disconnect the drive shift arm from the shift shaft.

/ 05. Remove the transmission case cover attaching bolts.

/ 06. Remove the transmission case cover, dowel pins and gasket.

/ 07. Inspect the bearings allowance play in the transmission case cover or the bearings turn

* If any defects are found, replace the bearing with a new one.



4-7-2. Transmission case cover disassembly (Fig. CVT 4-111, 4-112, 4-113, 4-114)

- / 01. Remove the drive axle circlip.
- / 02. Remove the drive axle from the transmission case cover.
- / 03. Remove the bearing circlip for remove the bearing.
- / 04. Inspect the bearing allowance play in the transmission case cover or the bearing turns
- / 05. If any defects are found, replace the bearing with a new one.
- / 06. Inspect the drive axle gear teeth for wear for damage.
- / 07. Remove the bearing to expose the oil seal. Inspect the oil seal for wear or damage.
 - * If any defects are found, replace the oil seal with a new one.
- / 08. Inspect the needle bearing allowance play in the transmission case cover or the bearing turns
 - * If any defects are found, replace the bearing with a new one.

4-7-3. Assembly (Fig. CVT 4-115)

- / 01. Install the needle bearing.
- / 02. Install the oil seal and bearing.
- / 03. Install the bearing circlip.
- / 04. Install the drive axle and drive axle circlip.

4-7-4. Transmission removal (Fig. CVT 4-116, 117, 118, 119, 120, 121, 122, 123, 124, 125, 126)

- / 01. Remove the transmission cover.
- / 02. Check the transmission operation.
 - * Unsmooth operation → Repair.
- / 03. Remove the shift shaft.
- / 04. Remove the stopper plug.
- / 05. Remove spring, washer and shift cam stopper.
- / 06. Remove the transmission guide bar and remove shift cam.
- / 07. Remove the shift fork.
- / 08. Measure the guide bar runout.
 - * Out of specification → Replace Service Limit: Less than 0.03 mm
- / 09. Do not attempt to straighten a bent guide bar.
- / 10. Inspect the shift fork cam follower and shift fork pawl.
 - * Scoring/beads/wear → Replace
- / 11. Check the shift cam groove and shift cam gear.
 - * Wear or damage → Replace.
- / 12. Inspect shift shaft gear.
 - * Damage → Replace.
- / 13. Inspect shift shaft.
 - * Damage/bends/wear → Replace.
- / 14. Remove the main axle.



4-7-5. Main axles disassembly (Fig. CVT 4-127, 128, 129, 130, 131, 132, 133)

- / 01. Remove the washers, collar, primary driven gear, bush and clutch dog.
- / 02. Remove the circlip and then remove the washers, reverse wheel ear and needle bearing.
- / 03. Inspect the gear teeth.
- / 04. Inspect mated dogs.
 - * Rounded edges/cracks/missing portions → Replace.
- / 05. Remove the counter axle.
- / 06. Inspect the gear teeth.
 - * Blue discoloration/pitting/wear → Replace.

4-7-6. Primary drive axles removal (Fig. CVT 4-134, 4-135)

- / 01. Remove the clutch/driven pulley.
- / 02. Remove the oil seal, circlip, screw and plate.
- / 03. Remove the primary drive axle.
- / 04. Inspect the bearings under allowance free play in the transmission case and bearing
 - * If any defects are found, replace the bearing with a new one.

4-7-7. Installation (Fig. CVT 4-136, 4-137, 4-138)

- / 01. Reverse the "TRANSMISSION REMOVAL" section procedures.
- / 02. Install the primary drive axle.
- / 03. Install the counter axle and the main axle.
- / 04. Install the shift cam and the shift fork.
- / 05. Install the guide bar and the shift shaft.
- / 06. Ensure the gear change switch lever correctly engages with the locating slot on the shift shaft. Align the mark on the shift shaft gear with the mark on the shift cam gear.
- / 07. Install the shift cam stopper and tighten the plug.
 - * Torque: 4.5~5.0kgf-m
- / 08. Install the dowel pins and a new gasket onto the right crankcase.
- / 09. Install the transmission case cover and tighten the transmission case cover bolt.
 - * Torque: 2.4~3.0kgf-m
- / 10. Fill the engine with oil and install the oil filler bolt.
 - * Specified Gear Oil: SAE 90#
 - * Oil Capacity:
 - At disassembly : 0.4 liter
 - At change : 0.3 liter

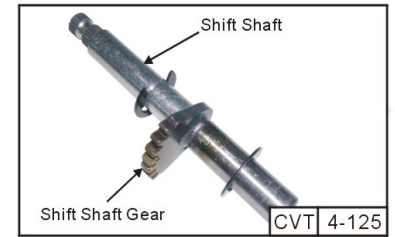
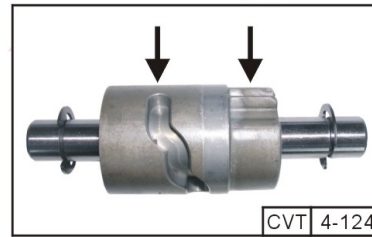
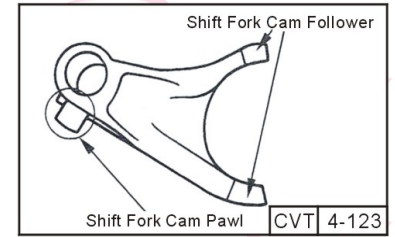
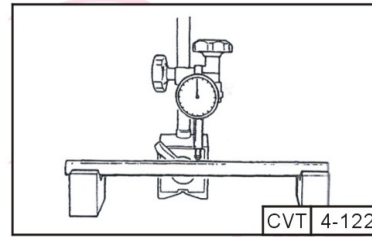
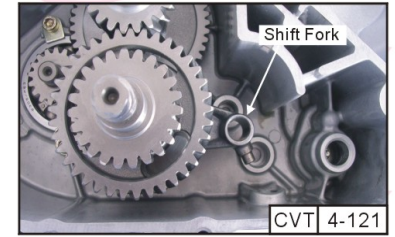
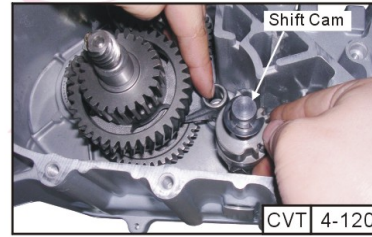
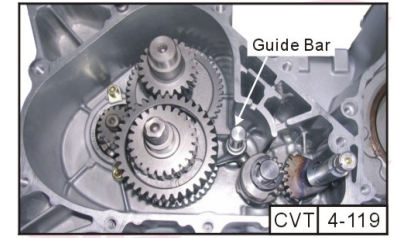
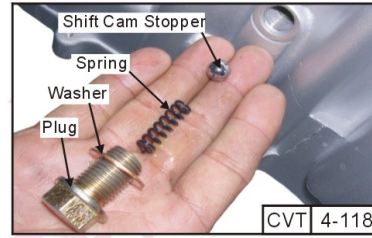
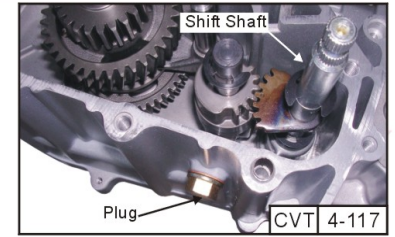
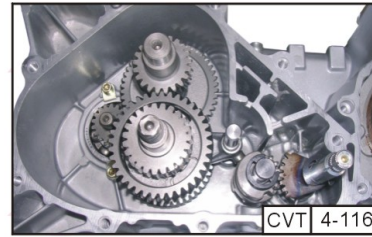
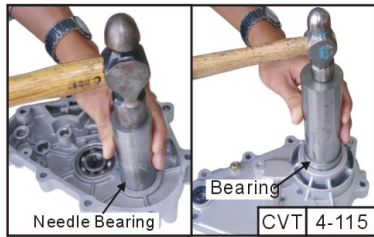
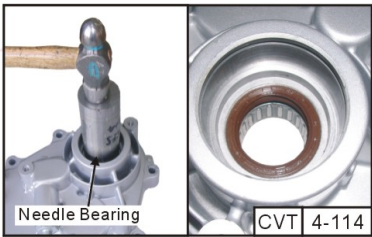
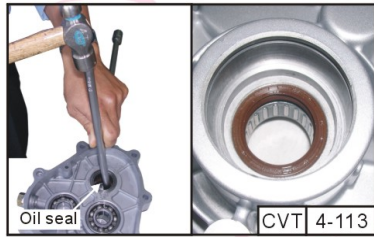
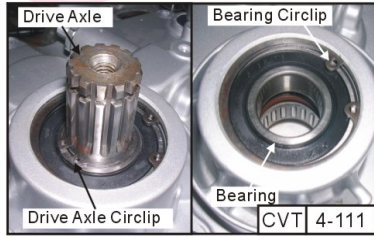
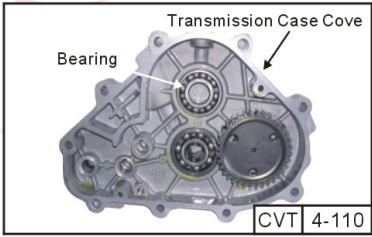
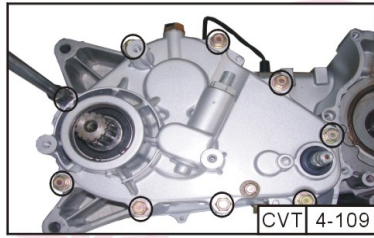
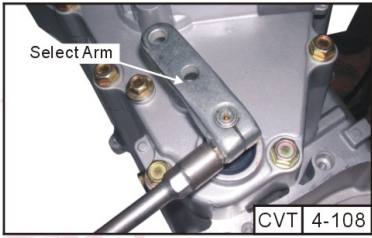
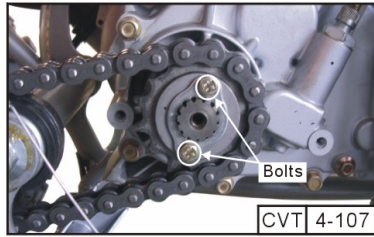
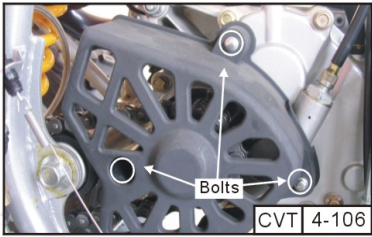

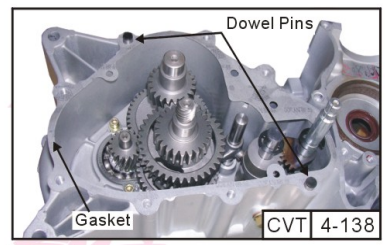
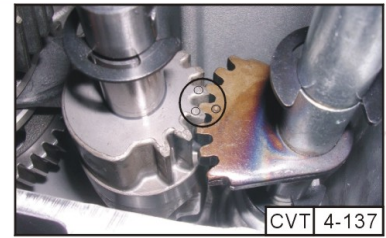
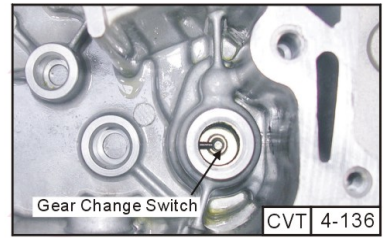
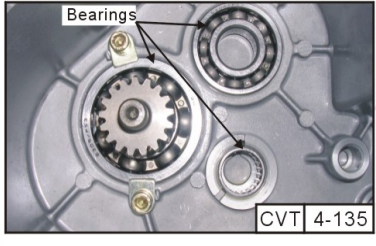
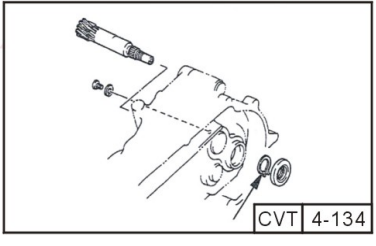
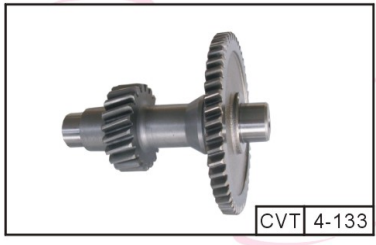
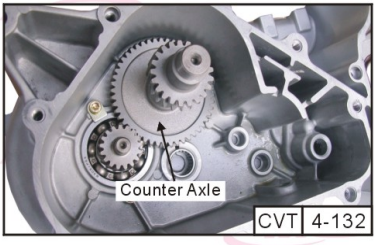
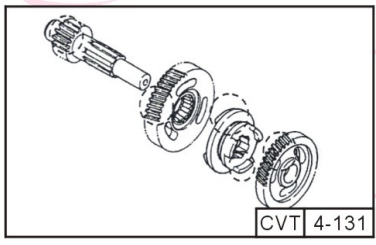
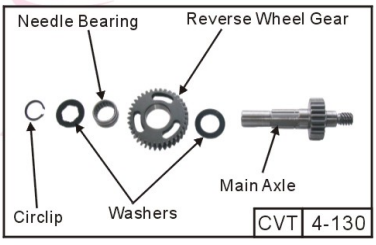
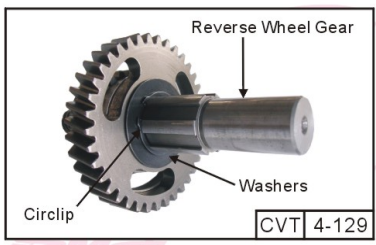
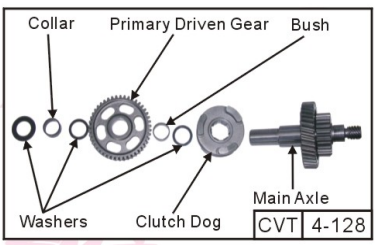
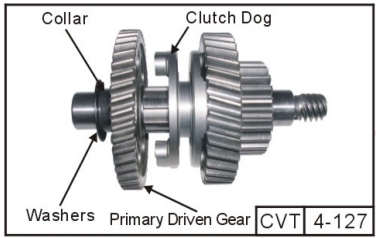
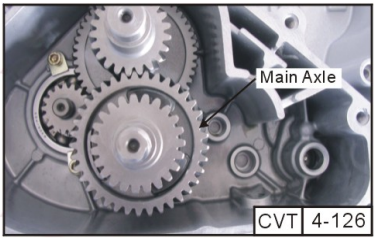



<4-8. CVT Crankcase/Crankshaft/Balance Shaft>

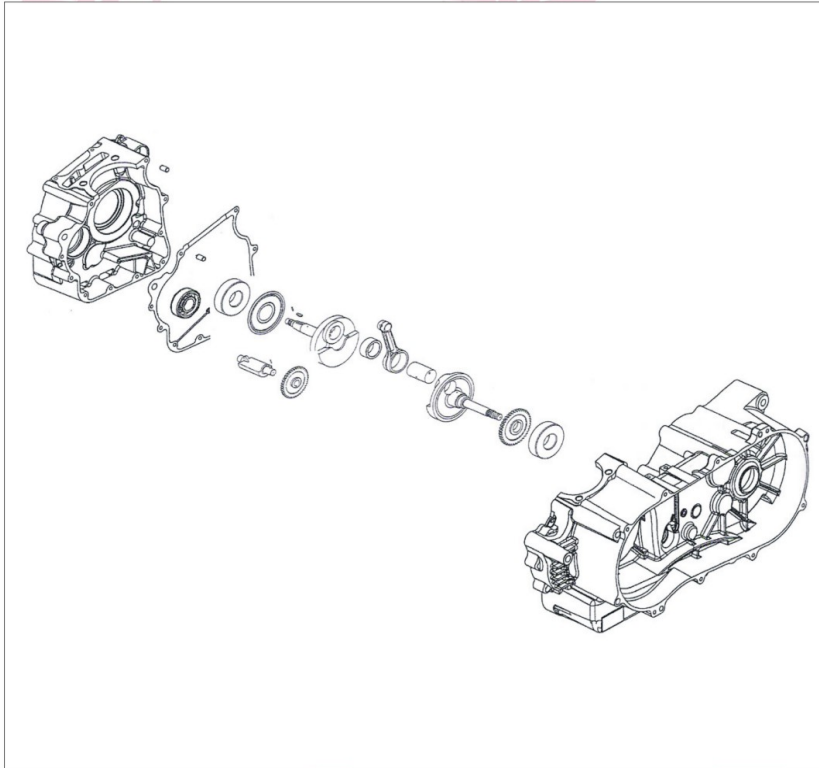

4-8. CVT Crankcase/Crankshaft/Balance Shaft

- NOTE: Service Information

	Item	Standard(mm)	Service Limit (mm)
Crankshaft	Connecting rod big end side clearance	0.05~0.4	0.6
	Connecting rod big end radial clearance	0~0.008	0.05
	Run out	--	0.10

* Torque value

Crankcase bolt	0.8~1.2kgf-m
Cam chain tension slipper bolt	0.8~1.2kgf-m
Cam chain cover bolt	0.8~1.2kgf-m

- NOTE: Problem Shooting:

<Q-A> Crankshaft noisy?

- . Worn connecting rod big end bearing
- . Bent connecting rod
- . Worn crankshaft main journal bearing

<Q-A> Transmission jumps out of gear?

- . Worn gear dogs or slots
- . Bent fork shaft
- . Worn or bent shift forks
- . Broken shift drum stopper
- . Broken shift linkage return spring

4-8-1. Crankcase/Crankshaft/Balace Shaft removal (Fig. CVT 4-139, 140, 141, 142, 143, 144)

- / 01. Remove the timing chain from right crankcase.
- / 02. Remove the left and right crankcase Attaching bolts.
- / 03. Separate the left and right crankcase halves.
 - * Do not damage the crankcase gasket surface.
- / 04. Remove the gasket and dowel pins.
- / 05. Remove the crankshaft from the left crankcase.
- / 06. Remove balance shaft from the left crankcase.
- / 07. Clean off all gasket material from the crankcase mating surfaces.
 - * Avoid damage the crankcase mating surfaces.
- / 08. Inspect the balance shaft gear teeth.
 - * Burs/chips/roughness/wear → Replace.



4-8-2. Crankshaft inspection (Fig. CVT 4-145, 4-146, 4-147)

- / 01. Inspect the crankshaft gear teeth. Burs/chips/roughness/wear → Replace
- / 02. Measure the connecting rod small end I.D.
* Service Limit:17.06 mm replace if over
- / 03. Measure the connecting rod small end free play (A).
* Out of specification (0.8~1.0mm) →Replace the crankshaft.
- / 04. Measure the crankshaft run out (B).
* Service Limit:0.10mm replace if over
- / 05. Measure the connecting rod big end side clearance (C).
* Service Limit:0.05mm replace if over
- / 06. Measure the crank width (D).
* Out of specification (55.15~55.2mm) →Replace the crankshaft.
- / 07. Turn the crankshaft bearings and check for excessive play.
- / 08. Measure the crankshaft bearing play.
* Service Limit: Axial: 0.20mm replace if over
Radial: 0.05mm replace if over

4-8-3. Crankcase/balancer installation

- / 01. Install the balance shaft and crankshaft into the left crankcase.
- / 02. Align the mark on the balance shaft with the mark on the crankshaft.
- / 03. Install the dowel pins and new gasket.
- / 04. Install the right crankcase and tighten
- / 05. Install the timing chain.

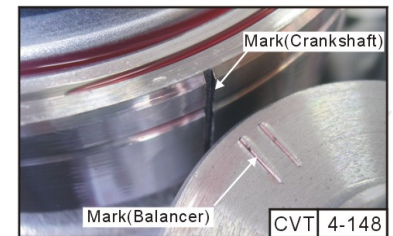
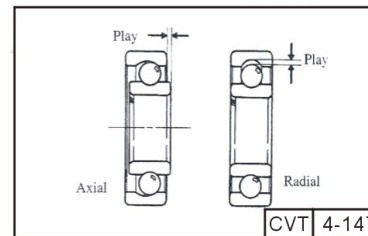
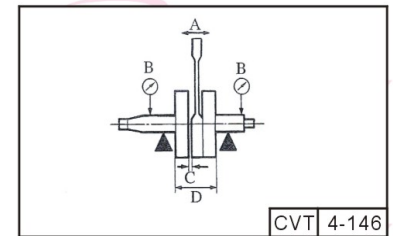
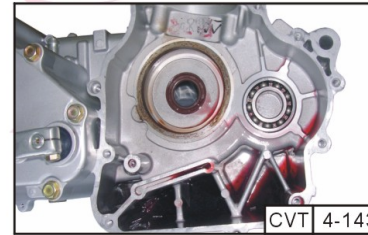
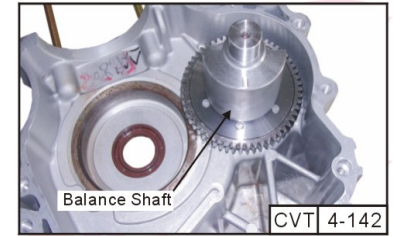
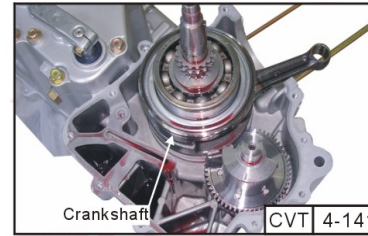
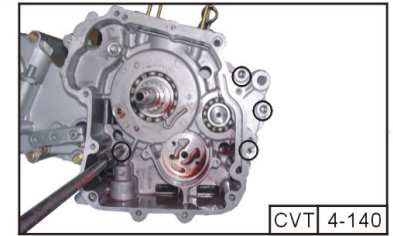
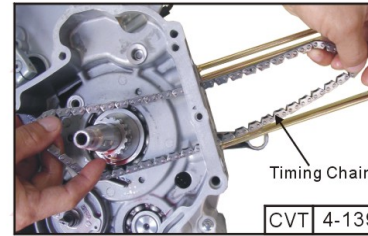



<5-9. CVT Water Cooling System>

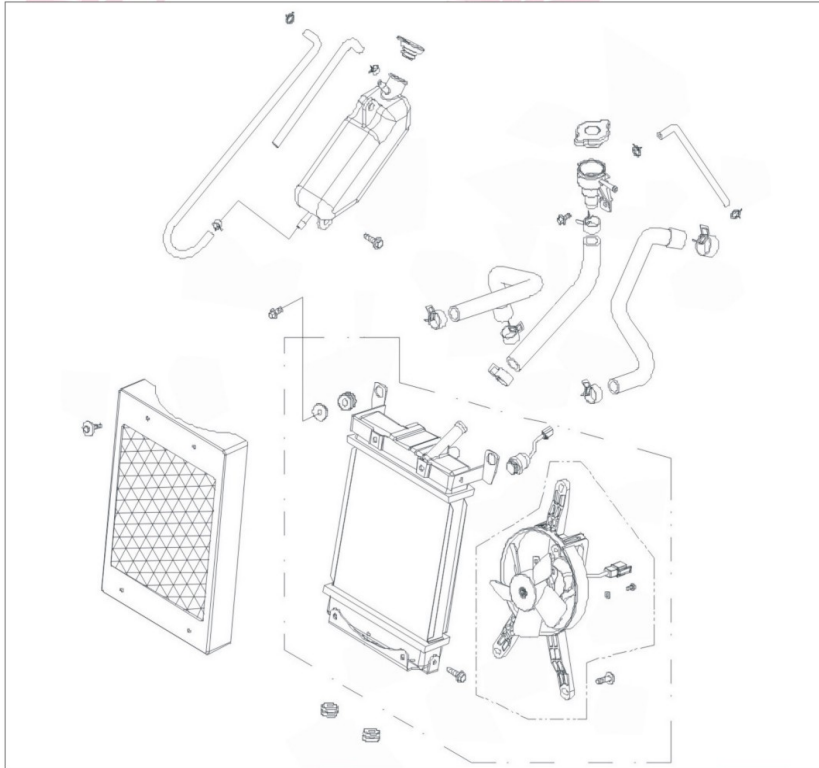

4-9. CVT Water Cooling System

- NOTE: Service Information

1. The water pump should be serviced after removing the engine. Other cooling system service can be done without remove the engine.
2. The engine must be cool before servicing the cooling system. Be sure do not remove the engine whenever the coolant temperature is hard. And, do not remove the radiator cap either.
3. Avoid spilling coolant on painted surfaces for the coolant will damage the painted surfaces.
4. After servicing the system, check for leaks with a cooling system tester.

SPECIFICATIONS

Radiator cap relief pressure		1.1±0.15 kg/cm ²	
Thermostat temperature	Begins to open	72±2°C	
	Full-open	90°C	
	Valve lift	3.5~4.5mm	
		Total system 1600±20cc	Radiator:1300±20cc Reverse tank:300±20cc

- Cautions:

1. Use coolant of specified mixing rate. 1.4 to 1.45 L coolant (standard concentration 50%)
2. Do not mix coolant concentrate of different brands.
3. The freezing point of coolant mixture shall be 5°C lower than the freezing point of the riding area – detail refer to the Area Importer information.

Special tool: Mechanical seal driver

Torque value:

- / 1. Water pump impeller 1.0~1.4kgf-m
- / 2. Water pump cover bolt 0.8~1.2kgf-m

- NOTE: Problems shooting <Q-A>

<Q-A> Engine temperature too high?

- . Faulty temperature gauge or thermo-sensor
- . Faulty radiator cap
- . Faulty thermostat
- . Insufficient coolant
- . Passages blocked in hoses or water jacket
- . Clogged radiator fins
- . Passages blocked in radiator
- . Faulty water pump

<Q-A> Temperature gauge pointer dose not register the correct coolant temperature?

- . Faulty temperature gauge or thermo-sensor
- . Faulty thermostat



4-9-01. Radiator cap inspection (Fig. CVT 4-149)

- / 01. Install the radiator cap onto the radiator tester and apply specified pressure to check.
- / 02. Put water on the cap sealing surface before testing.
 - * Radiator Cap Relief Pressure: 1.1±0.15 kg/cm²
- / 03. Install the radiator tester onto the radiator and apply specified pressure to it.
- / 04. Inspect the water hoses and connectors for leaks.

- Caution: The test pressure should not exceed 1.05kg/cm². Excessive pressure can damage the radiator and is hose

4-9-02. Radiator inspection (Fig. CVT 4-150)

- / 01. Take out the front fender.
- / 02. Check the radiator soldered joints and seams if there has any leaks.
- / 03. Drive dirt out from between core fins with clogging the radiator.
- / 04. Be straighten any bent fins.

4-9-03. Radiator removal (Fig. CVT 4-151, 4-152, 4-153)

- / 01. Drain the coolant and take out the front fender.
- / 02. Disconnect the air vent tube from the radiator filler.
- / 03. Remove the overflow tube clamp and disconnect the over tube.
- / 04. Disconnect the fan motor wire coupler and remove 2 bolts on the radiator filler hold plate.
- / 05. Remove the two bolts on the radiator and disconnect the thermostatic switch wire leads
- / 06. Loosen the hose bands and disconnect the upper hose and lower hose from the radiator.
- / 07. Pull the radiator upward to remove the radiator.

5-9-04. Radiator disassembly (Fig. CVT 4-154)

- / 01. Remove the three bolts and then remove the fan/shroud from the radiator.
- / 02. Check fan motor by battery.

4-9-05. Thermostatic switch (Fig. CVT 4-155)

- / 01. When coolant temperature lower 85-90c, the thermostatic switch OFF.
- / 02. When coolant temperature over 85-90c, the thermostatic switch ON.

4-9-06. Radiator assembly and installation

- / 01. Install the fan shroud on the radiator.
- / 02. Reverse the "RADIATOR REMOVAL" procedures
 - * the fan set is twin fan set.
- / 03. Fill the radiator with coolant and connect the vent tube to the radiator filler.
- / 04. After installation, check for coolant leaks.

- Caution: refill the coolant main points:

- (1).Take the radiator filler and the air vent tube to be separated.
- (2).Next, start the engine, filled in the coolant till the coolant flowed out from the air vent tube.
- (3).Finally, put the air vent tube on.

4-9-07. Water pump mechanical seal inspection (Fig. CVT 4-156)

- / 01. Inspect the telltale hole for sings of mechanical seal is leaking
- / 02. Remove the right crankcase cover and replace the mechanical seal.



4-9-08. Water pump/impeller removal (Fig. CVT 4-157, 4-158)

- / 01. Drain the coolant , loosen the bolts and the water pump cover.
 - / 02. Remove the gasket and 2 dowel pins
 - / 03. Remove the water pump impeller, washer and seal washer (porcelain).
 - * The impeller has left hand threads.
 - / 04. Inspect the mechanical(water) seal and seal washer for or damage.
- Caution: The mechanical seal and seal washer must be replace as a new set.

4-9-09. Water pump shaft removal (Fig. CVT 4-159, 4-160)

- / 01. Remove the water pump impeller and disconnect the water hose.
- / 02. Remove the bolts attaching the right crankcase cover.
- / 03. Remove the water pump bearing snap ring from the water pump assembly.
- / 04. Remove the water pump shaft and inner bearing.
- / 05. Remove the water pump shaft outer bearing.

4-9-10. Mechanical seal replacement (Fig. CVT 4-158)

- / 01. Drive the mechanical seal out of the water pump assembly from the inside.
- / 02. Drive in a new mechanical seal using a mechanical seal drive.
- / 03. Apply sealant to the right crankcase cover fitting surface of a new mechanical seal and then drive in the mechanical seal.

4-9-11. Water pump shaft installation (Fig. CVT 4-158)

- / 01. Drive a new water pump shaft outer bearing into the water pump assembly from the inside.
- / 02. Install the water pump shaft and shaft inner bearing into the waster pump assembly.
- / 03. Install the snap ring to secure the inner bearing properly.
- / 04. Install the dowel pins and a new gasket and then install the water pump
- / 05. Tighten the bolts
 - * When installing the water pump assembly, aligning the groove on the water pump shaft with tab on the oil pump shaft.

4-9-12. Water pump/impeller installation (Fig. CVT 4-161)

- / 01. Only replace a new seal washer
- / 02. Install the impeller onto the water pump shaft.
 - * Torque:1.0~1.4 kgf-m
- / 03. The impeller has left hand threads.
- / 04. Install the dowel pins and a new gasket.
- / 05. Install the water pump cover and tighten the bolts.
 - * Troque:0.8~1.2 kgf-m

4-9-13. Thermo-sensor removal and inspection (Fig. CVT 4-162)

- / 01. Drain the coolant and disconnect the thermo-sensor wire.
- / 02. Remove the thermo-sensor from the thermostat.
- / 03. Hand thermo-sensor into a liquid burner and measure the resistance through the sensor

Temperature(°C)	50	80	100	120
Resistance(Ω)	154	52	27	16

4-9-14. Thermo-sensor installation (Fig. CVT 4-163)

- / 01. Apply bond (quick gasket) to thermo-sensor threads, install it into the thermostat housing
- / 02. Connect the thermo-sensor wire.
- / 03. Fill the radiator with coolant.
- * Be sure to bleed air from the cooling system.

4-9-15. Thermostat removal (Fig. CVT 4-164, 4-165, 4-166)

- / 01. Drain the coolant and disconnect the thermo-sensor wire from the thermo-sensor.
- / 02. Disconnect the water hose from the thermostat housing.
- / 03. Disconnect the air vent tube from the thermostat housing.
- / 04. Remove the mounting bolt and the thermostat housing from the cylinder head.
- / 05. Remove the screws and separate the thermostat housing halves.
- / 06. Remove the thermostat from the thermostat housing.

4-9-16. Thermostat inspection (Fig. CVT 4-167)

- / 01. hand the thermostat in a liquid burner and raise the water temperature to check its operation.

* Technical Data

Begins to open	72±2°C
Full-open	90°C
Valve lift	3.5~4.5 mm

- / 02. Do not let the thermostat touch the burner surface.
- / 03. Replace the thermostat if the valve stays open at room temperature.
- / 04. Test the thermostat after it is opened for about 5 minutes and holds the temperature at 70°C.

4-9-17. Thermostat installation (Fig. CVT 4-168)

- / 01. The installation sequence is the reverse of removal.
- / 02. Replace the O-ring with a new one and apply grease to it.
- / 03. Fill the cooling system with the specified coolant.

