



**⚠ READ THIS MANUAL CAREFULLY!**  
It contains important safety information.

**OWNER'S MANUAL**

**GRIZZLY**

**550 FI**

**YFM5FGY/YFM5FGPY**

**⚠ WARNING**

This ATV should not be ridden by anyone under 16 years of age.

LIT-11626-22-19

28P-28199-10

EBU17092

## **WARNING**

**The engine exhaust from this product contains chemicals known to the State of California to cause cancer, birth defects or other reproductive harm.**

YAMAHA

LIT-CALIF-65-01

 **Read this manual carefully before operating this vehicle. This manual should stay with this vehicle if it is sold.**

# INTRODUCTION

Congratulations on your purchase of the Yamaha YFM5FGY/YFM5FGPY. This ATV represents the result of many years of Yamaha experience in the production of fine sporting, touring, and pace-setting racing machines. With the purchase of this Yamaha, you can now appreciate the high degree of craftsmanship and reliability that have made Yamaha a leader in these fields.

This manual will provide you with a good basic understanding of the features and operation of this ATV.

**This manual includes important safety information. It provides information about special techniques and skills necessary to ride the ATV.** It also includes basic maintenance and inspection procedures. If you have any questions regarding the operation or maintenance of your ATV, please consult a Yamaha dealer.



## **AN IMPORTANT SAFETY MESSAGE:**

- READ THIS MANUAL TOGETHER WITH TIPS FOR THE ATV RIDER CAREFULLY AND COMPLETELY BEFORE OPERATING YOUR ATV. MAKE SURE YOU UNDERSTAND ALL INSTRUCTIONS.
- PAY CLOSE ATTENTION TO THE WARNING AND NOTICE LABELS ON THE ATV.
- NEVER OPERATE AN ATV WITHOUT PROPER TRAINING OR INSTRUCTION. FREE TRAINING IS AVAILABLE TO ANYONE WHO BUYS A NEW ATV. CALL 1-800-887-2887 FOR MORE INFORMATION.
- THIS ATV, AND ANY OTHER ATV OVER 90 cc, SHOULD NOT BE RIDDEN BY ANYONE UNDER 16 YEARS OF AGE.

# IMPORTANT MANUAL INFORMATION

FAILURE TO FOLLOW THE WARNINGS CONTAINED IN THIS MANUAL CAN RESULT IN SERIOUS INJURY OR DEATH.

Particularly important information is distinguished in this manual by the following notations:

	<b>This is the safety alert symbol. It is used to alert you to potential personal injury hazards. Obey all safety messages that follow this symbol to avoid possible injury or death.</b>
	<b>A WARNING indicates a hazardous situation which, if not avoided, could result in death or serious injury.</b>
	<b>A NOTICE indicates special precautions that must be taken to avoid damage to the vehicle or other property.</b>
<b>TIP</b>	A TIP provides key information to make procedures easier or clearer.

\* Product and specifications are subject to change without notice.

## IMPORTANT NOTICE

Welcome to the Yamaha world of motor sports!

This ATV is designed and manufactured for OFF-ROAD use only. It is illegal and unsafe to operate this ATV on any public street, road or highway.

This ATV complies with all applicable OFF-ROAD noise level and spark arrester laws and regulations in effect at the time of manufacture.

Please check your local riding laws and regulations before operating this ATV.

**YFM5FGY/YFM5FGPY  
OWNER'S MANUAL  
©2008 by Yamaha Motor Corporation, U.S.A.  
1st edition, March 2008  
All rights reserved.  
Any reprinting or unauthorized use  
without the written permission of  
Yamaha Motor Corporation, U.S.A.  
is expressly prohibited.  
Printed in Japan.  
P/N LIT-11626-22-19**



**Indicates a potential hazard that could result in serious injury or death.**

## TABLE OF CONTENTS

SAFETY INFORMATION ..... 1-1

LOCATION OF THE WARNING AND  
SPECIFICATION LABELS ..... 2-1

DESCRIPTION ..... 3-1  
 Left view ..... 3-1  
 Right view ..... 3-1  
 Controls and instruments ..... 3-2

### INSTRUMENT AND CONTROL

FUNCTIONS ..... 4-1  
 Main switch ..... 4-1  
 Indicator lights and warning lights ..... 4-2  
 Multifunction display ..... 4-5  
 Handlebar switches ..... 4-7  
 Throttle lever ..... 4-13

Speed limiter ..... 4-14  
 Front brake lever ..... 4-15  
 Brake pedal and rear brake lever ..... 4-15  
 Drive select lever ..... 4-16  
 Fuel tank cap ..... 4-16  
 Fuel ..... 4-17  
 Seat ..... 4-19  
 Storage compartments ..... 4-19  
 Front carrier ..... 4-22  
 Rear carrier ..... 4-22  
 Adjusting the front and rear shock  
 absorber assemblies ..... 4-22  
 Auxiliary DC jack ..... 4-23

PRE-OPERATION CHECKS ..... 5-1  
 Pre-operation check list ..... 5-1  
 Fuel ..... 5-4  
 Engine oil ..... 5-4  
 Final gear oil ..... 5-4  
 Differential gear oil ..... 5-4  
 Coolant ..... 5-4  
 Front and rear brakes ..... 5-5  
 Throttle lever ..... 5-6  
 Tires ..... 5-6  
 Measuring the tire pressure ..... 5-7  
 Tire wear limit ..... 5-8  
 Chassis fasteners ..... 5-9

Instruments, lights and switches .....	5-9
<b>OPERATION .....</b>	<b>6-1</b>
Starting the engine .....	6-1
Operating the drive select lever and driving in reverse .....	6-3
Engine break-in .....	6-4
Parking .....	6-5
Parking on a slope .....	6-5
Accessories and loading .....	6-6
<b>RIDING YOUR ATV .....</b>	<b>7-1</b>
<b>GETTING TO KNOW YOUR ATV.....</b>	<b>7-2</b>
<b>RIDE WITH CARE AND GOOD   JUDGEMENT.....</b>	<b>7-3</b>
<b>BE CAREFUL WHERE YOU RIDE.....</b>	<b>7-13</b>
<b>TURNING YOUR ATV .....</b>	<b>7-19</b>
<b>CLIMBING UPHILL .....</b>	<b>7-21</b>
<b>RIDING DOWNHILL.....</b>	<b>7-25</b>
<b>CROSSING A SLOPE.....</b>	<b>7-27</b>
<b>CROSSING THROUGH SHALLOW   WATER .....</b>	<b>7-29</b>
<b>RIDING OVER ROUGH TERRAIN .....</b>	<b>7-31</b>
<b>SLIDING AND SKIDDING.....</b>	<b>7-32</b>
<b>WHAT TO DO IF.....</b>	<b>7-33</b>
<b>WHAT TO DO... .....</b>	<b>7-34</b>

<b>PERIODIC MAINTENANCE AND MINOR REPAIR .....</b>	<b>8-1</b>
Owner's manual and tool kit .....	8-1
Periodic maintenance chart for the emission control system .....	8-3
General maintenance and lubrication chart .....	8-4
Removing and installing panels .....	8-8
Removing the radiator grills .....	8-20
Checking the spark plug .....	8-20
Engine oil and oil filter cartridge .....	8-22
Final gear oil .....	8-27
Differential gear oil .....	8-29
Coolant .....	8-31
Cleaning the air filter element .....	8-37
Cleaning the spark arrester .....	8-41
V-belt case drain plug .....	8-43
Adjusting the throttle cable free play .....	8-44
Valve clearance .....	8-45
Adjusting the drive select lever safety system cable .....	8-45
Checking the front and rear brake pads .....	8-45
Checking the rear brake hose protectors .....	8-46
Checking the brake fluid level .....	8-47
Changing the brake fluid .....	8-48

Checking the front and rear brake lever free play .....	8-48
Adjusting the brake pedal free play .....	8-49
Axle boots .....	8-51
Checking and lubricating the cables .....	8-52
Checking and lubricating the front and rear brake levers .....	8-53
Checking and lubricating the brake pedal .....	8-53
Checking the wheel hub bearings .....	8-54
Checking the stabilizer bushes .....	8-54
Lubricating the rear knuckle pivots .....	8-54
Lubricating the steering shaft .....	8-55
Battery .....	8-55
Replacing a fuse .....	8-58
Replacing a headlight bulb .....	8-60
Adjusting a headlight beam .....	8-62
Replacing the tail/brake light bulb .....	8-63
Removing a wheel .....	8-64
Installing a wheel .....	8-64
Troubleshooting .....	8-65
Troubleshooting charts .....	8-67
CLEANING AND STORAGE.....	9-1
Cleaning .....	9-1
Storage .....	9-2

SPECIFICATIONS .....	10-1
CONSUMER INFORMATION.....	11-1
Identification numbers .....	11-1
Noise regulation .....	11-3
Maintenance record .....	11-4
YAMAHA MOTOR CORPORATION, U.S.A. ATV LIMITED WARRANTY .....	11-5
YAMAHA EXTENDED SERVICE (Y.E.S.) .....	11-7





## SAFETY INFORMATION

EBU27230

### **AN ATV IS NOT A TOY AND CAN BE HAZARDOUS TO OPERATE.**

An ATV handles differently from other vehicles, including motorcycles and cars. A collision or roll-over can occur quickly, even during routine maneuvers such as turning and riding on hills or over obstacles, if you fail to take proper precautions.

SEVERE INJURY OR DEATH can result if you do not follow these instructions:

- Read this manual and all labels carefully and follow the operating procedures described.
- Never operate an ATV without proper training or instruction. **Take a Training Course.** Beginners should receive training from a certified instructor. Contact an authorized ATV dealer or call 1-800-887-2887 to find out about the training courses nearest you.
- Always follow the age recommendation:
  - A child under 16 years old should never operate an ATV with engine size greater than 90 cc.
- Never allow a child under age 16 to operate an ATV without adult supervision, and never allow continued use of an ATV by a child if he or she does not have the abilities to operate it safely.
- Never carry a passenger on an ATV.
- Always avoid operating an ATV on any paved surfaces, including sidewalks, driveways, parking lots and streets.
- Never operate an ATV on any public street, road or highway, even a dirt or gravel one.
- Never operate an ATV without wearing an approved motorcycle helmet that fits properly. You should also wear eye protection (goggles or face shield), gloves, boots, a long-sleeved shirt or a jacket, and long pants.
- Never consume alcohol or drugs before or while operating this ATV.
- Never operate at speeds too fast for your skills or the riding conditions. Always go at a speed that is proper for the terrain, visibility, operating conditions, and your experience.
- Never attempt wheelies, jumps, or other stunts.

- Always inspect your ATV each time you use it to make sure it is in safe operating condition. Always follow the inspection and maintenance procedures and schedules described in this manual.
- Always keep both hands on the handlebars and both feet on the footboards of the ATV during operation.
- Always go slowly and be extra careful when operating on unfamiliar terrain. Always be alert to changing terrain conditions when operating the ATV.
- Never operate on excessively rough, slippery or loose terrain until you have learned and practiced the skills necessary to control the ATV on such terrain. Always be especially cautious on these kinds of terrain.
- Always follow proper procedures for turning as described in this manual. Practice turning at low speeds before attempting to turn at faster speeds and never turn at excessive speeds.
- Never operate the ATV on hills too steep for the ATV or for your abilities. Practice on smaller hills before attempting larger hills.
- Always follow proper procedures for climbing hills as described in this manual. Check the terrain carefully before you start up any hill. Never climb hills with excessively slippery or loose surfaces. Shift your weight forward. Never open the throttle suddenly. Never go over the top of a hill at high speed.
- Always follow proper procedures for going down hills and for braking on hills as described in this manual. Check the terrain carefully before you start down any hill. Shift your weight backward. Never go down a hill at high speed. Avoid going down a hill at an angle that would cause the vehicle to lean sharply to one side. Go straight down the hill where possible.
- Always follow proper procedures for crossing the side of a hill as described in this manual. Avoid hills with excessively slippery or loose surfaces. Shift your weight to the uphill side of the ATV. Never attempt to turn the ATV around on any hill until you have mastered the turning technique described in this manual on level ground. Avoid crossing the side of a steep hill if possible.
- Always use proper procedures if you stall or roll backwards when climbing a hill. To avoid stalling, use the proper gear range and maintain a

steady speed when climbing a hill. If you stall or roll backwards, follow the special procedure for braking described in this manual. Dismount on the uphill side or to a side if pointed straight uphill. Turn the ATV around and remount, following the procedure described in this manual.

- Always check for obstacles before operating in a new area.
- Never attempt to operate over large obstacles, such as large rocks or fallen trees. Always follow proper procedures when operating over obstacles as described in this manual.
- Always be careful when skidding or sliding. Learn to safely control skidding or sliding by practicing at low speeds and on level, smooth terrain. On extremely slippery surfaces, such as ice, go slowly and be very cautious in order to reduce the chance of skidding or sliding out of control.
- Never operate an ATV in fast flowing water or in water deeper than that recommended in this manual. Remember that wet brakes may have reduced stopping ability. Test your brakes after leaving water. If necessary, apply them several times to let friction dry out the linings.

- Always be sure there are no obstacles or people behind you when you operate in reverse. When it is safe to proceed in reverse, go slowly.
- Always use the size and type of tires specified in this manual.
- Always maintain proper tire pressure as described in this manual.
- Never modify an ATV through improper installation or use of accessories.
- Never exceed the stated load capacity for an ATV. Cargo should be properly distributed and securely attached. Reduce speed and follow instructions in this manual for carrying cargo or pulling a trailer. Allow greater distance for braking.

**FOR MORE INFORMATION ABOUT ATV SAFETY**, call the Consumer Products Safety Commission at 1-800-638-2772, or the ATV Distributor's Safety Hotline at 1-800-852-5344.

**⚠ WARNING****POTENTIAL HAZARD**

Improper handling of gasoline.

**WHAT CAN HAPPEN**

Gasoline can catch fire and you could be burned.

**HOW TO AVOID THE HAZARD**

Always turn off the engine when refueling.

Do not refuel right after the engine has been running and is still very hot.

Do not spill gasoline on the engine or exhaust pipe/muffler when refueling.

Never refuel while smoking, or in the vicinity of sparks, open flames, or other sources of ignition such as the pilot lights of water heaters and clothes dryers.

When transporting the ATV in another vehicle, be sure it is kept upright. Otherwise, fuel may leak out of the fuel tank.

**WHAT CAN HAPPEN**

Gasoline is poisonous and can cause injuries.

**HOW TO AVOID THE HAZARD**

If you should swallow some gasoline or inhale a lot of gasoline vapor, or get some gasoline in your eyes, seek medical help immediately. If gasoline spills on your skin, wash with soap and water. If gasoline spills on your clothing, change your clothes.

EWB00030

**⚠ WARNING****POTENTIAL HAZARD**

Starting or running the engine in a closed area.

**WHAT CAN HAPPEN**

Exhaust fumes are poisonous and may cause loss of consciousness and death within a short time.

**HOW TO AVOID THE HAZARD**

Always operate your ATV in an area with adequate ventilation.

# LOCATION OF THE WARNING AND SPECIFICATION LABELS

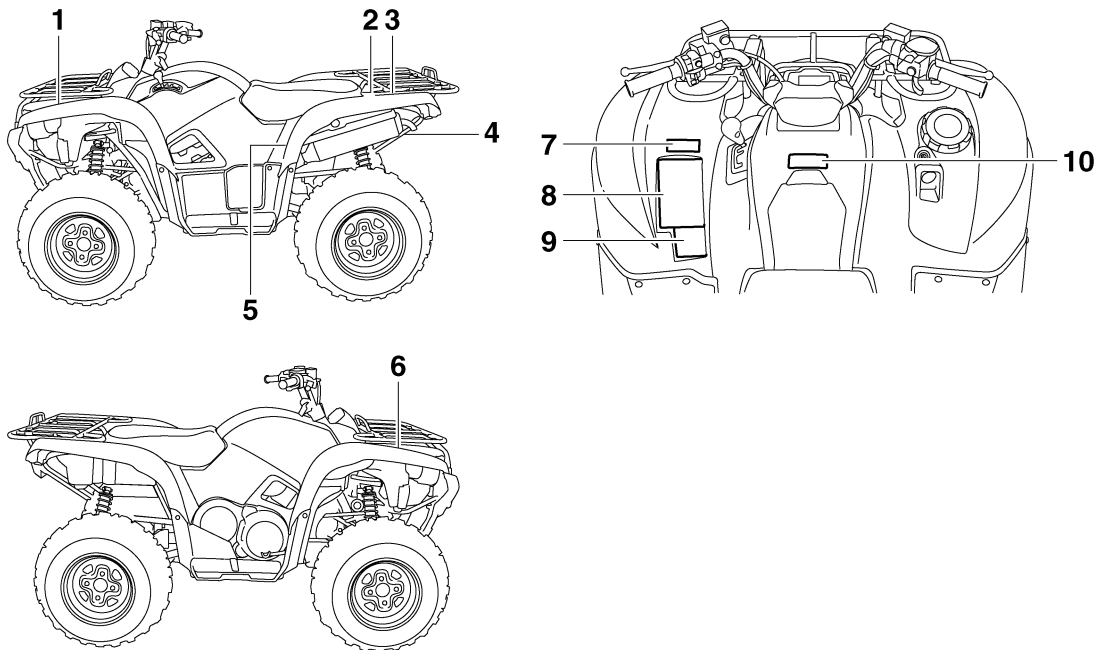

Read and understand all of the labels on your ATV. These labels contain important information for safe and proper operation.

2

Never remove any labels from your ATV. If a label becomes difficult to read or comes off, request a replacement label from your Yamaha dealer.

1

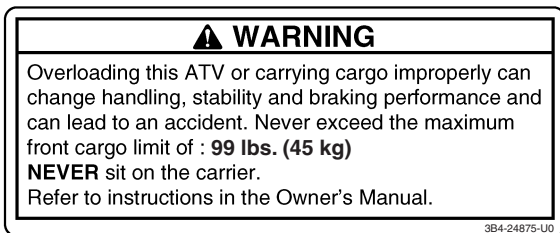

3

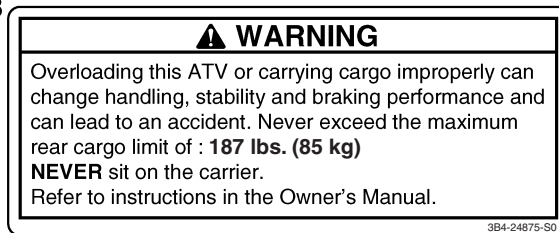

2

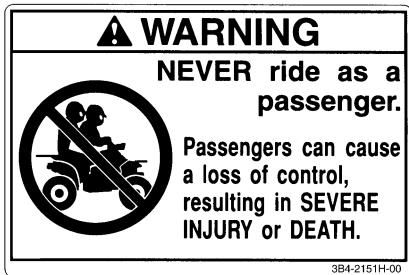

4

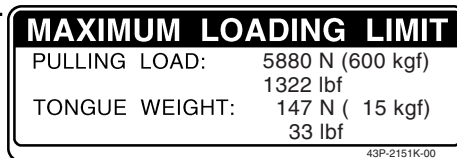

5

## WARNING

Improper tire pressure or overloading can cause loss of control.

Loss of control can result in severe injury or death.

**OPERATING TIRE PRESSURE** : Set with tires cold

- Recommended : Front : 5.0 psi (35.0 kPa)  
Rear : 4.4 psi (30.0 kPa)
- Minimum : Front : 4.6 psi (32.0 kPa)  
Rear : 4.0 psi (27.0 kPa)
- Never set tire pressure below minimum.  
It could cause the tire to dislodge from the rim.

### **LOADING / TRAILER TOWING**

- Cargo or a trailer can affect stability and handling. Read owner's manual before loading or towing.
- When loading with cargo or towing a trailer :  
Reduce speed and allow more room to stop.  
Avoid hills and rough terrain.
- Maximum weight capacity : 485 lbs. (220 kg)  
Includes weight of operator, cargo and accessories  
(and if applicable, trailer tongue weight).

28P-2816M-U0

6

## WARNING

- Fuel vapors can be a fire or explosion hazard.  
To avoid injury or death, never store fuel or flammable liquids in this storage compartment.
- Storage should not exceed 1 lb (0.5 kg).

3B4-2151F-U0

2

7

## **DRIVE SELECT LEVER**

- Read owner's manual carefully before operating.
- ATV **MUST** be stopped before shifting select lever.
- Shifting into or from reverse or park is impossible without applying rear brake.

5GH-2151E-00

8

**⚠ WARNING**

Improper ATV use can result in **SEVERE INJURY or DEATH.**





**ALWAYS USE AN APPROVED HELMET AND PROTECTIVE GEAR**

**NEVER USE ON PUBLIC ROADS**

**NEVER CARRY PASSENGERS**

**NEVER USE WITH DRUGS OR ALCOHOL**

**NEVER** operate :

- without proper training or instruction.
- at speeds too fast for your skills or the conditions.
- on public roads - a collision can occur with another vehicle.
- with a passenger - passengers affect balance and steering and increase risk of losing control.

**ALWAYS :**

- use proper riding techniques to avoid vehicle overturns on hills and rough terrain and in turns.
- avoid paved surfaces - pavement may seriously affect handling and control.

**LOCATE AND READ OWNER'S MANUAL. FOLLOW ALL INSTRUCTIONS AND WARNINGS. (For replacement manual, call 1-800-532-1558)**

5FE-21568-01

9

**⚠ WARNING**



**Operating this ATV if you are under the age of 16 increases your chance of severe injury or death.**

**NEVER** operate this ATV if you are under age 16.

4D3-2816L-00

10

**⚠ WARNING**

Turning the ATV in 4WD-LOCK("DIFF. LOCK") takes more effort.

Operate at a slow speed and allow extra time and distance for maneuvers to avoid loss of control.

5KM-21558-00



## DESCRIPTION

EBU17690

### Left view

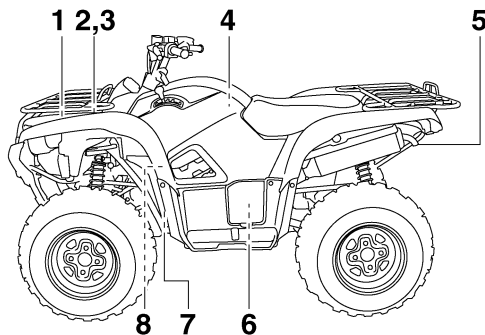

1. Radiator cap
2. Battery
3. Fuses
4. Air filter case
5. Spark arrester
6. Engine oil dipstick
7. Oil filter cartridge
8. Coolant reservoir

EBU17700

### Right view

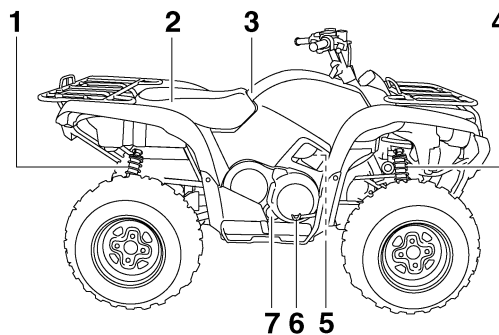

1. Rear shock absorber assembly spring preload adjusting ring
2. Rear storage compartment and tool kit
3. Fuel tank cap cover
4. Front shock absorber assembly spring preload adjusting ring
5. Spark plug
6. Brake pedal
7. V-belt case drain plug

## Controls and instruments

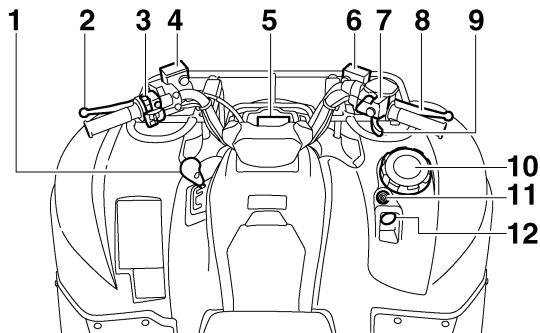

### TIP

The ATV you have purchased may differ slightly from the figures shown in this manual.

3

1. Drive select lever
2. Rear brake lever
3. Handlebar switches
4. Rear brake fluid reservoir
5. Multifunction display
6. Front brake fluid reservoir
7. On-Command four-wheel-drive/differential gear lock switch
8. Front brake lever
9. Throttle lever
10. Front storage compartment
11. Main switch
12. Auxiliary DC jack

# INSTRUMENT AND CONTROL FUNCTIONS

EWB00010



Indicates a potential hazard that could result in serious injury or death.

EBU17760

## Main switch

The positions of the main switch are as follows:

### ON

All electrical systems are supplied with power. The headlights and taillight come on when the light switch is on, and the engine can be started. The key cannot be removed.

### OFF

All electrical systems are off. The key can be removed.

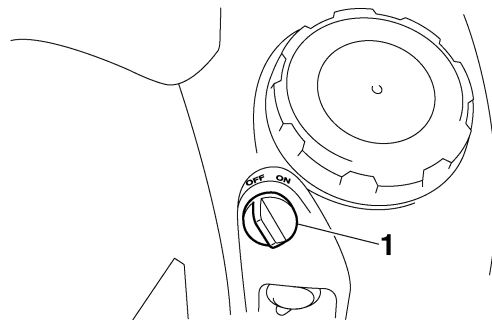

1. Main switch

## Indicator lights and warning lights

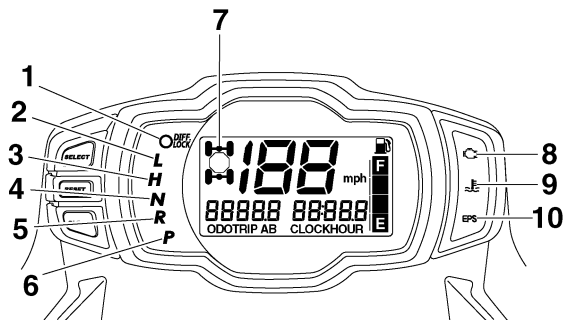

1. On-Command differential gear lock indicator light “DIFF. LOCK”
2. Low-range indicator light “L”
3. High-range indicator light “H”
4. Neutral indicator light “N”
5. Reverse indicator light “R”
6. Park indicator light “P”
7. On-Command four-wheel-drive/differential gear lock indicator “/””
8. Engine trouble warning light “”
9. Coolant temperature warning light “”
10. Electric Power Steering warning light “EPS” (for EPS model)

### Reverse indicator light “R”

This indicator light comes on when the transmission is in the reverse position.

### Neutral indicator light “N”

This indicator light comes on when the transmission is in the neutral position.

### Coolant temperature warning light “”

This warning light comes on when the engine overheats. When this occurs during operation, stop the engine as soon as it is safe to do so and allow it to cool down for about 10 minutes.

The electrical circuit of the warning light can be checked by turning the key to “ON”. If the warning light does not come on, have a Yamaha dealer check the electrical circuit.

### NOTICE

- **The engine may overheat if the ATV is overloaded. In this case, reduce the load to specification.**

- The engine may also overheat if mud or dirt has accumulated on the radiator (i.e., after riding in wet terrain). In this case, see page 8-20 for an explanation on how to access the radiator.
  - Start the engine after making sure that the warning light is out. Continuous use while the warning light is on may cause damage to the engine.
- 

EBU27280

### Engine trouble warning light “ ”

This warning light comes on or flashes when an electrical circuit monitoring the engine is defective. When this occurs, have a Yamaha dealer check the self-diagnosis system. (See page 4-5 for an explanation of the self-diagnosis device.)

The electrical circuit of the warning light can be checked by turning the key to “ON”. If the warning light does not come on, then go off, have a Yamaha dealer check the electrical circuit.

EBU29060

### Electric Power Steering warning light “EPS” (for EPS model)

This warning light comes on when the key is turned to “ON”, and then goes off once the engine is started. If the warning light remains on or comes on after the engine is started, the EPS system may be defective. When this occurs, have a Yamaha dealer check the EPS system.

The electrical circuit of the warning light can be checked by turning the key to “ON”. If the warning light does not come on, have a Yamaha dealer check the electrical circuit.

### TIP

---

- If the engine is stopped using the engine stop switch and the key is in the “ON” position, the EPS warning light comes on to indicate that the power assistance for the steering is not functioning.
  - If the steering load is too heavy (i.e., excessive steering use when the ATV is traveling at a slow speed), the power assist is reduced to protect the EPS motor from overheating.
-

EBU17961

### **On-Command four-wheel-drive/differential gear lock indicator “”/“”**

The On-Command four-wheel-drive indicator “” comes on when the On-Command four-wheel-drive switch is set to the “4WD” position.

The On-Command differential gear lock indicator “” in the On-Command four-wheel-drive indicator also comes on when the On-Command differential gear lock switch is set to the “LOCK” position.

#### **TIP**

---

- Due to the synchronizing mechanism in the differential gear case, the four-wheel-drive indicator may not come on until the ATV starts moving.
  - When the On-Command differential gear lock switch is set to “LOCK”, the indicator “” will flash until the differential gear is locked.
- 

EBU17970

### **Park indicator light “P”**

This indicator light comes on when the transmission is in the park position.

EBU17980

### **High-range indicator light “H”**

This indicator light comes on when the transmission is in the high-range position.

EBU17990

### **Low-range indicator light “L”**

This indicator light comes on when the transmission is in the low-range position.

EBU18001

### **On-Command differential gear lock indicator light “DIFF. LOCK”**

This indicator light and the On-Command differential gear lock indicator in the display come on when the On-Command differential gear lock switch is set to the “LOCK” position.

#### **TIP**

---

When the switch is set to “LOCK”, the On-Command differential gear lock indicator light will flash until the differential gear is locked.

---

## Multifunction display

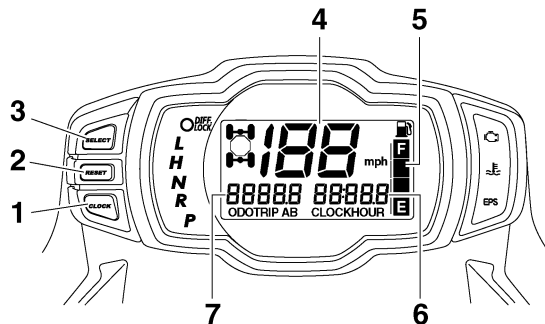

1. "CLOCK" button
2. "RESET" button
3. "SELECT" button
4. Speedometer
5. Fuel meter
6. Clock/Hour meter
7. Odometer/Tripmeter A/Tripmeter B

The multifunction display is equipped with the following:

- a speedometer (which shows the riding speed)
- an odometer (which shows the total distance traveled)
- two tripmeters (which show the distance traveled since they were last set to zero)

- a clock
- an hour meter (which shows the total time the engine has been running)
- a fuel meter
- a self-diagnosis device

### Odometer and tripmeter modes

Pushing the "SELECT" button switches the display between the odometer mode "ODO" and the tripmeter modes "A" and "B" in the following order:

ODO → TRIP A → TRIP B → ODO

To reset a tripmeter, select it by pushing the "SELECT" button, and then push the "RESET" button for at least three seconds. The tripmeters can be used to estimate the distance that can be traveled with a full tank of fuel. This information will enable you to plan future fuel stops.

### TIP

Pushing and holding in the "SELECT" button, and turning the key to "ON" while the button is pushed, switches the display between "mph" and "km/h".

### Clock mode

Pushing the "CLOCK" button switches the display between the clock mode "CLOCK" and the hour meter mode "HOUR" in the following order:

CLOCK → HOUR → CLOCK

### To set the clock

1. Set the display to the clock mode.
2. Push the “SELECT” button and “RESET” button together for at least three seconds.
3. When the hour digits start flashing, push the “RESET” button to set the hours.
4. Push the “SELECT” button, and the minute digits will start flashing.
5. Push the “RESET” button to set the minutes.
6. Push the “SELECT” button and then release it to start the clock.

### Fuel meter

The fuel meter indicates the amount of fuel in the fuel tank. The display segments of the fuel meter disappear from “F” (full) towards “E” (empty) as the fuel level decreases. When the “E” segment disappears and the fuel level warning indicator flashes, refuel as soon as possible.

### TIP

This fuel meter is equipped with a self-diagnosis system. If the electrical circuit is defective, all the display segments and fuel level warning indicator will start flashing. If this occurs, have a Yamaha dealer check the electrical circuit.

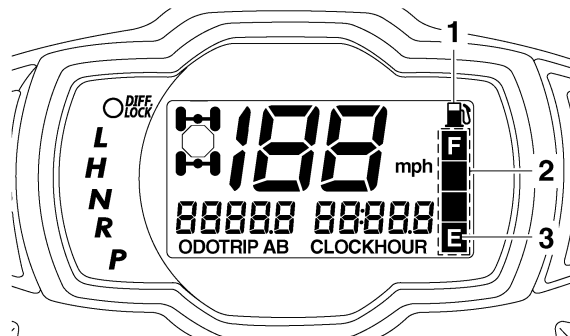

1. Fuel level warning indicator
2. Fuel meter
3. “E” segment



## Self-diagnosis device

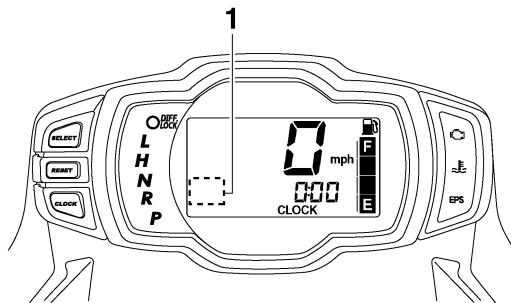

### 1. Error code display

This model is equipped with a self-diagnosis device for various electrical circuits.

If any of those circuits are defective, the multifunction display will indicate a two-digit error code.

If the multifunction display indicates such an error code, note the code number, and then have a Yamaha dealer check the vehicle.

ECB00810

### **NOTICE**

**If the multifunction display indicates an error code, the vehicle should be checked as soon as possible in order to avoid engine damage.**

EBU18061

## Handlebar switches

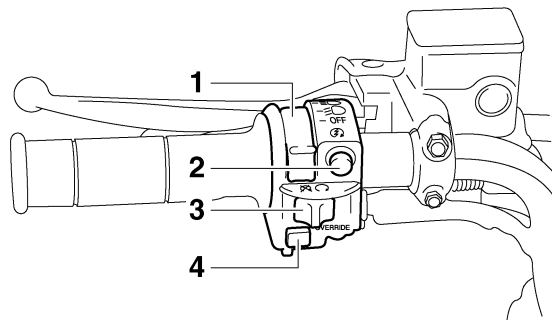

1. Light switch “ $\equiv$  /  $\equiv$  / OFF”
2. Start switch “ $\text{\textcircled{S}}$ ”
3. Engine stop switch “ $\text{\textcircled{X}}$  /  $\text{\textcircled{O}}$ ”
4. Override switch “OVERRIDE”

EBU18080

### **Engine stop switch “ $\text{\textcircled{X}}$ / $\text{\textcircled{O}}$ ”**

Set this switch to “ $\text{\textcircled{O}}$ ” before starting the engine. The engine stop switch controls the ignition and stops the engine when it is running. Use this switch to stop the engine in an emergency situation. The engine will not start or run when this switch is set to “ $\text{\textcircled{X}}$ ”.

EBU18100

### Start switch “”

Push this switch to crank the engine with the starter.

ECB00050



#### **NOTICE**

**See the starting instructions on page 6-1 prior to starting the engine.**

4

EBU18151

### Light switch “ / / OFF”

Set this switch to “” to turn on the low beams and the taillight. Set the switch to “” to turn on the high beams and the taillight. Set the switch to “OFF” to turn off all the lights.

ECB00040

#### **NOTICE**

**Do not use the headlights with the engine turned off for an extended period of time, otherwise the battery may discharge to the point that the starter motor will not operate properly. If this should happen, remove the battery and recharge it.**

EBU18180

### Override switch “**VERRIDE**”

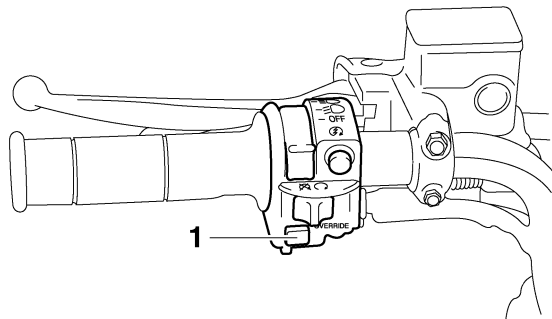

1. Override switch “**VERRIDE**”

Top speed is normally limited when operating in differential gear lock. If conditions require more engine power when riding forward, push and hold this switch to override the differential gear lock speed limiting function. (See page 4-10.) Releasing the switch restores the speed limiting function.

While the override switch is pushed, the segments of the speedometer digits will appear as shown in the figure.

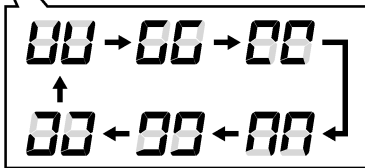
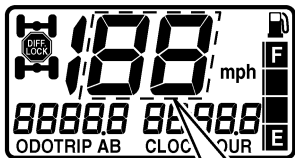

## TIP

If the digits of the speedometer appear as shown when the switch is NOT being pushed, this could indicate a malfunction in the electrical system. In this case, take the ATV to a Yamaha dealer at the first opportunity.

EWB00110



## WARNING

### POTENTIAL HAZARD

**Riding too fast while the ATV is in four-wheel-drive differential gear lock.**

## WHAT CAN HAPPEN

All wheels turn at the same speed when the differential is locked, so it takes more effort to turn the ATV. The effort needed to turn increases with the riding speed. You may lose control and have an accident if you cannot make a sharp enough turn for the speed you are traveling.

## HOW TO AVOID THE HAZARD

Always ride at a slow speed when the ATV is in four-wheel-drive differential gear lock, and allow extra time and distance for maneuvers.

EBU26634

## On-Command four-wheel-drive switch “2WD”/“4WD”

This ATV is equipped with a switch to change from two-wheel drive to four-wheel drive and vice versa. Select the appropriate drive according to the terrain and the conditions.

- “2WD” (two-wheel drive): Power is supplied to the rear wheels.
- “4WD” (four-wheel drive): Power is supplied to the rear and front wheels.

To change from two-wheel drive to four-wheel drive, stop the ATV and push the switch in to the “4WD” position. Then, the four-wheel-drive indicator “” comes on in the multifunction display.

To change from four-wheel drive to two-wheel drive, stop the ATV and push the switch in to the “2WD” position.

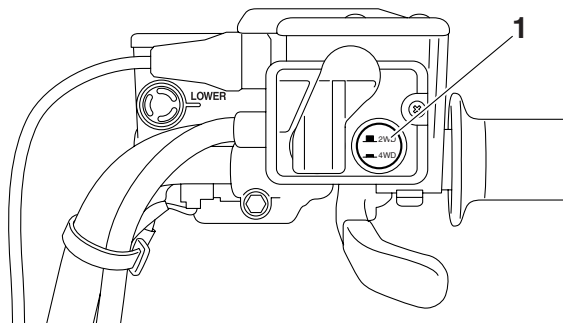

1. On-Command four-wheel-drive switch “2WD”/“4WD”

EWB00121



## WARNING

### POTENTIAL HAZARD

**Changing from two-wheel drive to four-wheel drive or from four-wheel drive to two-wheel drive while the ATV is moving.**

## WHAT CAN HAPPEN

**The ATV handles differently in two-wheel drive than in four-wheel drive in some circumstances. Changing from two-wheel drive to four-wheel drive or from four-wheel drive to two-wheel drive while moving may cause the ATV to unexpectedly handle differently. This could distract the operator and increase the risk of losing control and of causing an accident.**

## HOW TO AVOID THE HAZARD

**Always stop the ATV before changing from two-wheel drive to four-wheel drive or vice versa.**

EBU18245

## **On-Command differential gear lock switch “4WD”/“LOCK”**

This ATV is equipped with a switch allowing you to lock the differential gear when in four-wheel drive. Select the appropriate switch position according to the terrain and the conditions.

- “4WD” (four-wheel drive): Power is supplied to the rear and front wheels.

- “LOCK” (four-wheel drive with the differential gear locked): Power is supplied to the rear and front wheels and the differential gear is locked. Unlike in four-wheel drive, all wheels turn at the same speed.

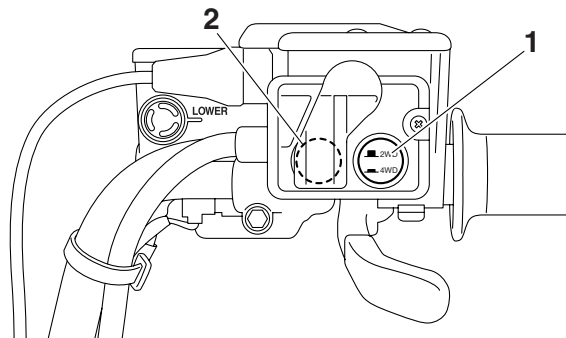

1. On-Command four-wheel-drive switch “2WD”/“4WD”
2. On-Command differential gear lock switch “4WD”/“LOCK”

To lock the differential gear in four-wheel drive, make sure the On-Command four-wheel-drive switch is pushed in to the “4WD” position.

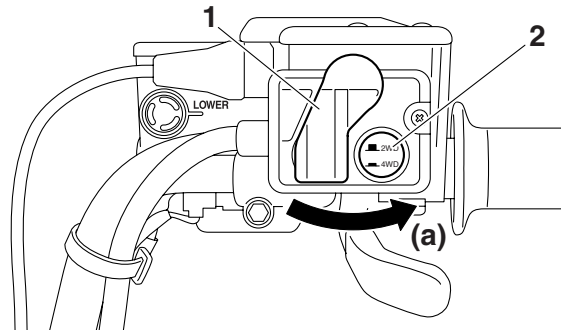

1. Differential gear lock lever
2. On-Command four-wheel-drive switch “2WD”/“4WD”

Stop the ATV, move the differential gear lock lever to position (a), and then push the differential gear lock switch in to the “LOCK” position. When the differential gear is locked, the differential gear lock indicator light “DIFF. LOCK” will come on along with the indicator “” in the multifunction display.

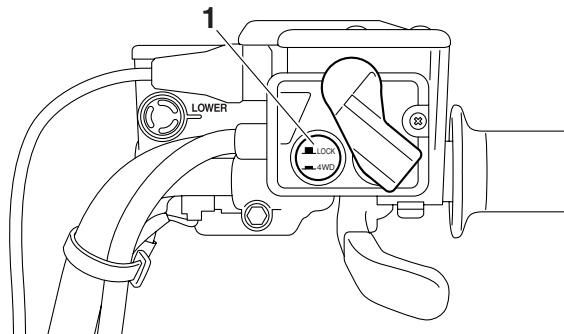

1. On-Command differential gear lock switch “4WD”/“LOCK”

To release the differential gear lock, stop the ATV and push the switch to the “4WD” position.

EWB00092

### **! WARNING**

#### **POTENTIAL HAZARD**

Changing from four-wheel drive to four-wheel-drive differential gear lock or vice versa while the ATV is moving.

#### **WHAT CAN HAPPEN**

The ATV handles differently in four-wheel drive than in differential gear lock in some circumstances. Changing from four-wheel drive to differential gear lock or vice versa while moving may cause the ATV to handle differently unexpectedly. This could distract the operator and increase the risk of losing control and causing an accident.

#### **HOW TO AVOID THE HAZARD**

Always stop the ATV before changing from four-wheel drive to four-wheel-drive differential gear lock or vice versa.

EWB00101

### **! WARNING**

#### **POTENTIAL HAZARD**

Riding too fast while the ATV is in four-wheel-drive differential gear lock.

#### **WHAT CAN HAPPEN**

All wheels turn at the same speed when the differential gear is locked, so it takes more effort to turn the ATV. The effort needed to turn increases with the riding speed. You may lose control and have an accident if you cannot make a sharp enough turn for the speed you are traveling.

## HOW TO AVOID THE HAZARD

**Always ride at a slow speed when the ATV is in differential gear lock, and allow extra time and distance for maneuvers.**

### TIP

- When the switch is set to “LOCK”, the differential gear lock indicator and indicator light will flash until the differential gear is locked.
- When the indicator and indicator light are flashing, turning the handlebar back and forth will help the differential gear lock to engage.
- Riding before the differential gear lock is properly engaged (e.g., when the indicator and indicator light are flashing) will cause the engine speed to be limited until engagement is complete.
- When the ATV is in four-wheel-drive differential gear lock, the maximum traveling speed is limited to 35 km/h (22 mi/h). However, if conditions require full engine power to be available, push and hold the override switch to disable the differential gear lock speed limiter. (See page 4-8 for a detailed explanation of this switch.)

EBU18270

## Throttle lever

Once the engine is running, movement of the throttle lever will increase the engine speed.

Regulate the speed of the ATV by varying the throttle position. Because the throttle is spring-loaded, the ATV will decelerate, and the engine will return to an idle any time the hand is removed from the throttle lever.

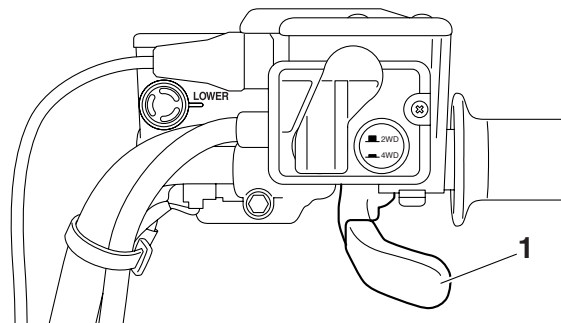

1. Throttle lever

Before starting the engine, check the throttle to be sure it is operating smoothly. Make sure it returns to the idle position as soon as the lever is released.

**! WARNING****POTENTIAL HAZARD****Malfunction of throttle.****WHAT CAN HAPPEN**

The throttle could be hard to operate, making it difficult to speed up or slow down when you need to. This could cause an accident.

**HOW TO AVOID THE HAZARD**

Check the operation of the throttle lever before you start the engine. If it does not work smoothly, check for the cause. Correct the problem before riding the ATV. Consult a Yamaha dealer if you can't find or solve the problem yourself.

4

**Speed limiter**

Your ATV was delivered with an adjustable speed limiter. The speed limiter keeps the throttle from fully opening, even when the throttle lever is pushed to the maximum.

1. Loosen the locknut.
2. To increase the maximum engine power available and the maximum speed of the ATV, turn the adjusting screw in direction (a). To decrease the maximum engine power available and the maximum speed of the ATV, turn the adjusting screw in direction (b).

crease the maximum engine power available and the maximum speed of the ATV, turn the adjusting screw in direction (b).

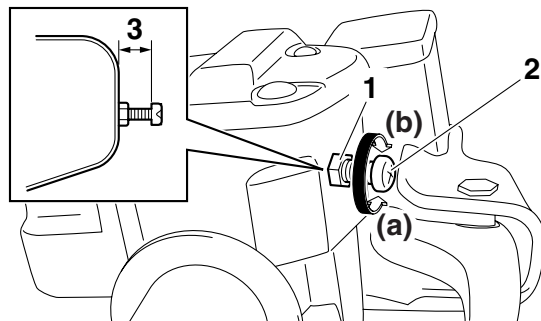

1. Locknut
2. Adjusting screw
3. No more than 12 mm (0.47 in)

3. Tighten the locknut.

**! WARNING****POTENTIAL HAZARD****Improper adjustment of the speed limiter and throttle.**



## **WHAT CAN HAPPEN**

The throttle cable could be damaged. Improper throttle operation could result. You could lose control, have an accident or be injured.

## **HOW TO AVOID THE HAZARD**

Do not turn the adjusting screw out more than 12 mm (0.47 in). Always make sure the throttle lever free play is adjusted to 3.0–5.0 mm (0.12–0.20 in). (See page 8-44.)

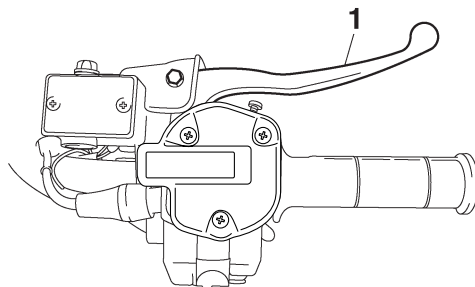

1. Front brake lever

EBU18391

## **Front brake lever**

The front brake lever is located on the right handlebar. To apply the front brake, pull the brake lever toward the handlebar grip.

EBU18442

## **Brake pedal and rear brake lever**

The brake pedal is located on the right side of the ATV and the rear brake lever is located on the left handlebar. To apply the rear brake, push down on the brake pedal or pull the brake lever toward the handlebar grip.

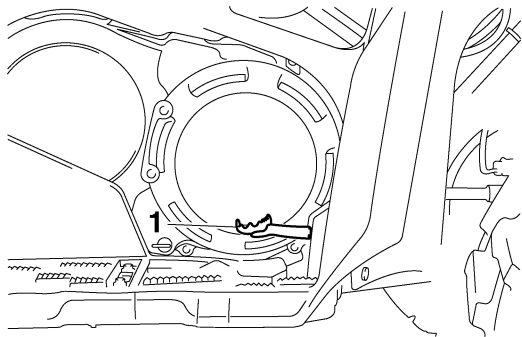

1. Brake pedal

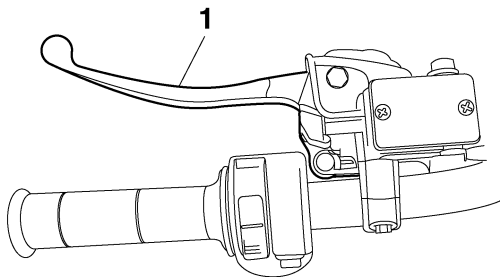

1. Rear brake lever

EBU18611

## Drive select lever

The drive select lever is used to shift your ATV into the low-range, high-range, neutral, reverse and park positions. See the “Operating the drive select lever and driving in reverse” section on page 6-3 for the drive select lever operation.

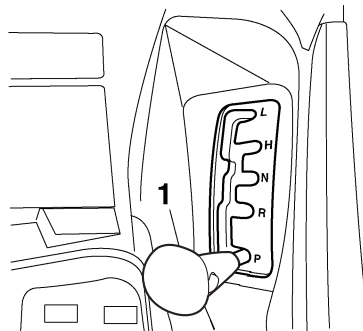

1. Drive select lever

EBU27350

## Fuel tank cap

### To remove the fuel tank cap

Open the fuel tank cap cover, and then remove the fuel tank cap by turning it counterclockwise.

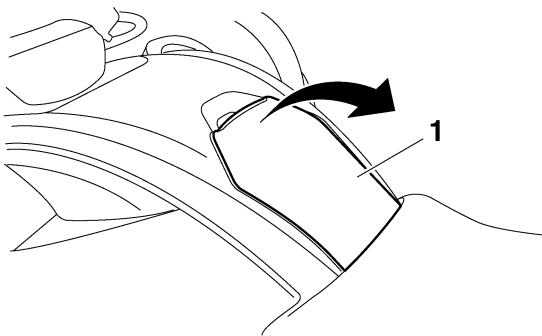

1. Fuel tank cap cover

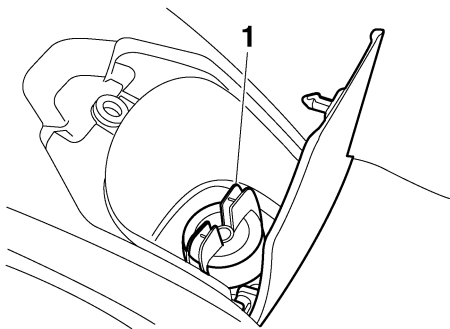

1. Fuel tank cap

### To install the fuel tank cap

Install the fuel tank cap by turning it clockwise until a click is heard, and then close the fuel tank cap cover.

EBU18730

### Fuel

Make sure that there is sufficient fuel in the tank. Fill the fuel tank to the bottom of the filler tube as shown.

4

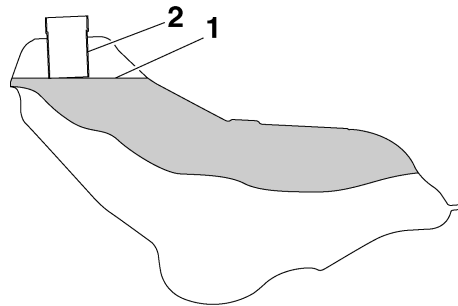

- 1. Fuel level
- 2. Fuel tank filler tube

Recommended fuel:

**UNLEADED GASOLINE ONLY**

Fuel tank capacity:

20.0 L (5.28 US gal, 4.40 Imp.gal)

Fuel reserve amount:

4.5 L (1.19 US gal, 0.99 Imp.gal)

methanol is not recommended by Yamaha because it can cause damage to the fuel system or ATV performance problems.

EWB00270

 **WARNING**

**POTENTIAL HAZARD**

**Improper care when refueling.**

**WHAT CAN HAPPEN**

**Fuel can spill, which can cause a fire and severe injury.**

**Fuel expands when it heats up. If the fuel tank is overfilled, fuel could spill out due to heat from the engine or the sun.**

**HOW TO AVOID THE HAZARD**

**Do not overfill the fuel tank. Be careful not to spill fuel, especially on the engine or exhaust pipe. Wipe up any spilled fuel immediately. Be sure the fuel tank cap is closed securely.**

**Do not refuel right after the engine has been running and is still very hot.**

4

ECB00070

**NOTICE**

**Use only unleaded gasoline. The use of leaded gasoline will cause severe damage to internal engine parts, such as the valves and piston rings, as well as to the exhaust system.**

Your Yamaha engine has been designed to use regular unleaded gasoline with a pump octane number [(R+M)/2] of 86 or higher, or a research octane number of 91 or higher. If knocking or pinging occurs, use a different brand of gasoline or premium unleaded fuel. Unleaded fuel will give you longer spark plug life and reduced maintenance cost.

**Gasohol**

There are two types of gasohol: gasohol containing ethanol and that containing methanol. Gasohol containing ethanol can be used if the ethanol content does not exceed 10%. Gasohol containing

## Seat

### To remove the seat

Pull the seat lock lever upward and pull up the seat at the rear.

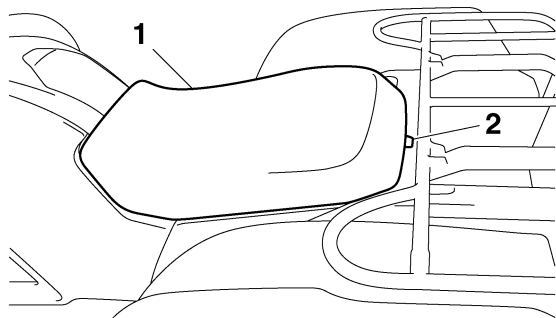

1. Seat
2. Seat lock lever

### To install the seat

Insert the projections on the front of the seat into the seat holders and push down on the seat at the rear.

### TIP

Make sure that the seat is securely fitted.

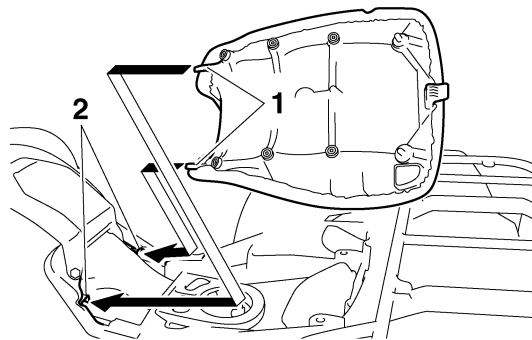

1. Projection
2. Seat holder

EBU27361

## Storage compartments

This ATV is equipped with two storage compartments.

The front storage compartment is located at the front right side of the ATV. To access the storage compartment, remove the storage compartment cover by turning it counterclockwise.

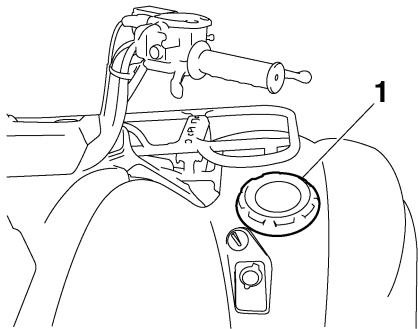

1. Front storage compartment cover

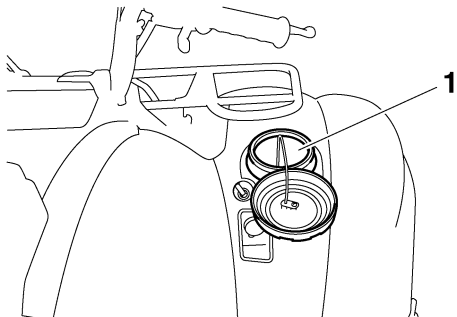

1. Front storage compartment

The rear storage compartment is located under the seat. (See page 4-19.) To access the storage compartment, remove the storage compartment cover.

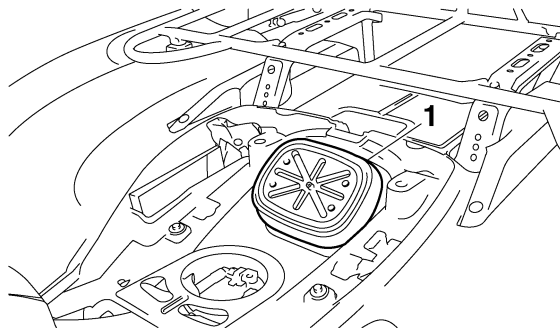

1. Rear storage compartment cover

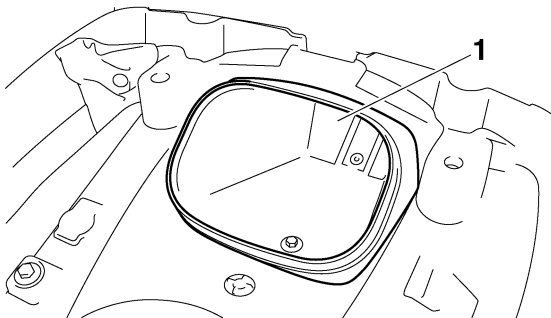

1. Rear storage compartment

When storing any documents in the storage compartments, be sure to wrap them in a plastic bag so that they will not get wet. When washing the ATV, be careful not to let any water enter the storage compartments.

ECB00830

**NOTICE**

**Do not store metal or sharply edged objects, like tools, in the storage compartments. If they must be stored, wrap them in appropriate cushion material to prevent damaging the storage compartments.**

- Do not exceed the load limit of 0.5 kg (1 lb) for the front storage compartment or 2.0 kg (4 lb) for the rear storage compartment.
- Do not exceed the maximum load of 220.0 kg (485 lb) for the ATV.

**TIP**

A drain plug is fitted at the bottom of each storage compartment. If any water collects in a storage compartment, remove the drain plug, drain the water, and then install the drain plug.

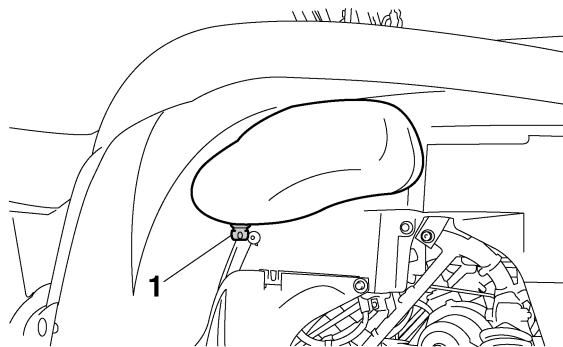

1. Storage compartment drain plug

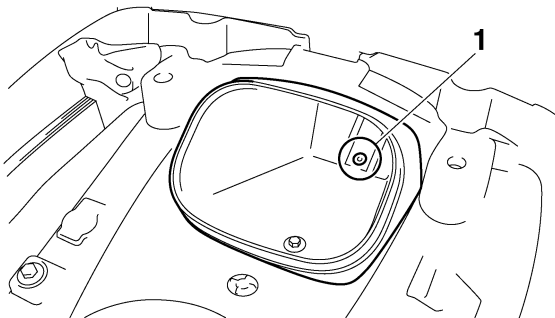

1. Storage compartment drain plug

EBU18961

### Front carrier

- Do not exceed the load limit of 45.0 kg (99 lb) for the front carrier.
- Do not exceed the maximum load of 220.0 kg (485 lb) for the ATV.

EBU18971

### Rear carrier

- Do not exceed the load limit of 85.0 kg (187 lb) for the rear carrier.
- Do not exceed the maximum load of 220.0 kg (485 lb) for the ATV.

EBU19131

## Adjusting the front and rear shock absorber assemblies

The spring preload can be adjusted to suit the rider's weight and the riding conditions.

Adjust the spring preload as follows.

Turn the spring preload adjusting ring in direction (a) to increase the spring preload and thereby harden the suspension, and in direction (b) to decrease the spring preload and thereby soften the suspension.

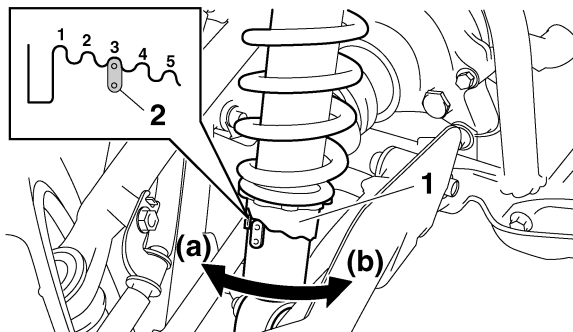

1. Spring preload adjusting ring
2. Position indicator



**TIP**

A special wrench can be obtained at a Yamaha dealer to make this adjustment.

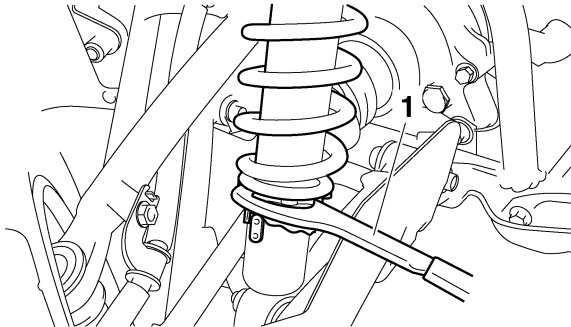

1. Special wrench

**Spring preload setting:**

Minimum (soft):

1

Standard:

3

Maximum (hard):

5

**⚠ WARNING**

**POTENTIAL HAZARD**

Improper shock absorber assembly adjustment.

**WHAT CAN HAPPEN**

Uneven adjustment can cause poor handling and loss of stability, which could lead to an accident.

**HOW TO AVOID THE HAZARD**

Always adjust the shock absorber assemblies on the left and right side to the same setting.

EBU19181

**Auxiliary DC jack**

The auxiliary DC jack is located at the front right side of the ATV. The auxiliary DC jack can be used for suitable work lights, radios, etc. The auxiliary DC jack should only be used when the engine is running.

1. Set the light switch to "OFF".
2. Start the engine. (See page 6-1.)
3. Open the auxiliary DC jack cap, and then insert the accessory power plug into the jack.

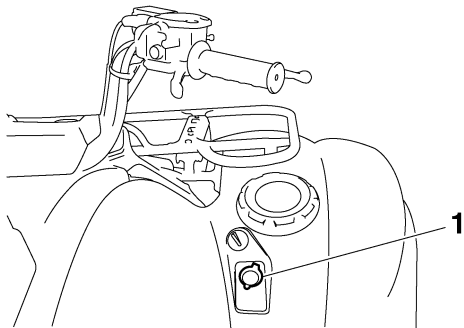

1. Auxiliary DC jack cap

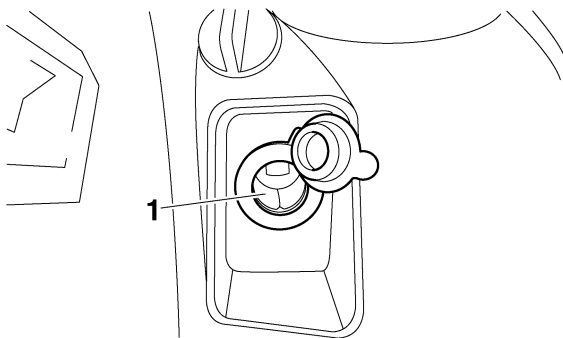

1. Auxiliary DC jack

Maximum rated capacity for the auxiliary DC jack:

DC 12 V, 10 A (120 W)

- When the auxiliary DC jack is not being used, cover it with the cap.

ECB00120

### NOTICE

- Do not use accessories requiring more than the above maximum capacity. This may overload the circuit and cause the fuse to blow.
- If accessories are used without the engine running or with the headlights turned on, the battery will lose its charge and engine starting may become difficult.
- Do not use an automotive cigarette lighter or other accessories with a plug that gets hot because the jack can be damaged.

EWB00010

### ! WARNING

Indicates a potential hazard that could result in serious injury or death.

# PRE-OPERATION CHECKS

EBU19212

## Pre-operation check list

Before operating this ATV, be sure to check the items listed in the following table.

EWB00470



### WARNING

#### POTENTIAL HAZARD

Failure to inspect the ATV before operating.

Failure to properly maintain the ATV.

#### WHAT CAN HAPPEN

Increases the possibility of an accident or equipment damage.

#### HOW TO AVOID THE HAZARD

Always inspect your ATV each time you use it to make sure it is in safe operating condition.

Always follow the inspection and maintenance procedures and schedules described in the Owner's Manual.

5

### TIP

The maintenance of some items in the table has to be performed by a Yamaha dealer. Refer to the periodic maintenance charts on page 8-3 to determine which service should be performed by a Yamaha dealer.

ITEM	ROUTINE	PAGE
Fuel	<ul style="list-style-type: none"> <li>• Check fuel level in fuel tank, and add recommended fuel if necessary.</li> <li>• Check fuel line for leakage. Correct if necessary.</li> </ul>	4-17, 5-4

ITEM	ROUTINE	PAGE
<b>Engine oil</b>	<ul style="list-style-type: none"> <li>• Check oil level in engine, and add recommended oil to specified level if necessary.</li> <li>• Check ATV for oil leakage. Correct if necessary.</li> </ul>	5-4, 8-22
<b>Final gear oil</b>	<ul style="list-style-type: none"> <li>• Check ATV for oil leakage. Correct if necessary.</li> </ul>	5-4, 8-27
<b>Differential gear oil</b>	<ul style="list-style-type: none"> <li>• Check ATV for oil leakage. Correct if necessary.</li> </ul>	5-4, 8-29
<b>Coolant</b>	<ul style="list-style-type: none"> <li>• Check coolant level in reservoir, and add recommended coolant to specified level if necessary.</li> <li>• Check cooling system for leakage. Correct if necessary.</li> </ul>	5-4, 8-31
<b>Front brake</b>	<ul style="list-style-type: none"> <li>• Check operation. If soft or spongy, have Yamaha dealer bleed hydraulic system.</li> <li>• Check brake pads for wear, and replace if necessary.</li> <li>• Check brake fluid level in reservoir, and add recommended brake fluid to specified level if necessary.</li> <li>• Check hydraulic system for leakage. Correct if necessary.</li> </ul>	5-5, 8-45, 8-47, 8-48
<b>Rear brake</b>	<ul style="list-style-type: none"> <li>• Check operation. If soft or spongy, have Yamaha dealer bleed hydraulic system.</li> <li>• Check pedal free play, and adjust if necessary.</li> <li>• Check brake pads for wear, and replace if necessary.</li> <li>• Check brake fluid level in reservoir, and add recommended brake fluid to specified level if necessary.</li> <li>• Check hydraulic system for leakage. Correct if necessary.</li> </ul>	5-5, 8-45, 8-47, 8-48, 8-49
<b>Throttle lever</b>	<ul style="list-style-type: none"> <li>• Make sure that operation is smooth. Lubricate cable and lever housing if necessary.</li> <li>• Check cable free play, and adjust if necessary.</li> </ul>	5-6, 8-44
<b>Control cables</b>	<ul style="list-style-type: none"> <li>• Make sure that operation is smooth. Lubricate if necessary.</li> </ul>	8-52
<b>Wheels and tires</b>	<ul style="list-style-type: none"> <li>• Check wheel condition, and replace if damaged.</li> <li>• Check tire condition and tread depth. Replace if necessary.</li> <li>• Check air pressure. Correct if necessary.</li> </ul>	5-6, 5-7, 5-8
<b>Brake pedal</b>	<ul style="list-style-type: none"> <li>• Make sure that operation is smooth. Lubricate pedal pivoting point if necessary.</li> </ul>	8-53

ITEM	ROUTINE	PAGE
<b>Brake levers</b>	<ul style="list-style-type: none"> <li>• Make sure that operation is smooth. Lubricate lever pivoting points if necessary.</li> </ul>	8-53
<b>Axle boots</b>	<ul style="list-style-type: none"> <li>• Check for cracks or damage, and replace if necessary.</li> </ul>	8-51
<b>Chassis fasteners</b>	<ul style="list-style-type: none"> <li>• Make sure that all nuts, bolts and screws are properly tightened.</li> </ul>	5-9
<b>Instruments, lights and switches</b>	<ul style="list-style-type: none"> <li>• Check operation, and correct if necessary.</li> </ul>	5-9

EBU19530

## Fuel

Make sure that there is sufficient fuel in the tank. (See page 4-17.)

EWB00500

### WARNING

#### POTENTIAL HAZARD

Improper care when refueling.

#### WHAT CAN HAPPEN

Fuel can spill, which can cause a fire and severe injury.

Fuel expands when it heats up. If the fuel tank is overfilled, fuel could spill out due to heat from the engine or the sun.

#### HOW TO AVOID THE HAZARD

Do not overfill the fuel tank. Be careful not to spill fuel, especially on the engine or exhaust pipe. Wipe up any spilled fuel immediately. Be sure the fuel tank cap is closed securely.

Do not refuel right after the engine has been running and is still very hot.

EBU19560

## Engine oil

Make sure that the engine oil is at the specified level. Add oil as necessary. (See page 8-22.)

EBU19590

## Final gear oil

Make sure that the final gear oil is at the specified level. Add oil as necessary. (See page 8-27.)

EBU19600

## Differential gear oil

Make sure that the differential gear oil is at the specified level. Add oil as necessary. (See page 8-29.)

EBU19620

## Coolant

Make sure that the coolant is at the specified level. Add coolant as necessary. (See page 8-31.)

### TIP

The coolant level must be checked on a cold engine since the level varies with engine temperature.

EWB00490

### WARNING

#### POTENTIAL HAZARD

Removing the radiator cap when the engine and radiator are still hot.

### **WHAT CAN HAPPEN**

**You could be burned by hot fluid and steam blown out under pressure.**

### **HOW TO AVOID THE HAZARD**

**Wait for the engine to cool before removing the radiator cap. Always use a thick rag over the cap. Allow any remaining pressure to escape before completely removing the cap.**

EBU29010

## **Front and rear brakes**

### **Brake levers and brake pedal**

- Check that there is no free play in the front and rear brake levers. If there is free play, have a Yamaha dealer check the brake system.
- Check for correct free play in the brake pedal. If the free play is incorrect, adjust it. (See page 8-49.)
- Check the operation of the brake levers and pedal. They should move smoothly and there should be a firm feeling when the brakes are applied. If not, have a Yamaha dealer check the brake system.

### **Brake fluid level**

Check the brake fluid level. Add fluid if necessary. (See page 8-47.)

Recommended brake fluid:  
DOT 4

### **Brake fluid leakage**

Check to see if any brake fluid is leaking out of the pipe joints or brake fluid reservoirs. Apply the brakes firmly for one minute. If a lever moves slowly inward, there may be a leak in the brake system. If there is any leakage, the brake system should be checked by a Yamaha dealer.

### **Brake operation**

Test the brakes at slow speed after starting out to make sure they are working properly. If the brakes do not provide proper braking performance, check the brake pads for wear. (See page 8-45.)

**⚠ WARNING****POTENTIAL HAZARD**

Riding with improperly operating brakes.

**WHAT CAN HAPPEN**

You could lose braking ability, which could lead to an accident.

**HOW TO AVOID THE HAZARD**

Always check the brakes at the start of every ride. Do not ride the ATV if you find any problem with the brakes. If a problem cannot be corrected by the adjustment procedures provided in this manual, have a Yamaha dealer check for the cause.

5

**Throttle lever**

Check the operation of the throttle lever. It must open smoothly and spring back to the idle position when released. Have a Yamaha dealer correct if necessary.

**Tires****⚠ WARNING****POTENTIAL HAZARD**

Operating this ATV with improper tires, or with improper or uneven tire pressure.

**WHAT CAN HAPPEN**

Use of improper tires on this ATV, or operation of this ATV with improper or uneven tire pressure, may cause loss of control, increasing your risk of accident.

**HOW TO AVOID THE HAZARD**

- The tires listed below have been approved by Yamaha Motor Co., Ltd. for this model. Other tire combinations are not recommended.

**Front:**

**Manufacturer/model:**

**DUNLOP/KT421**

**Size:**

**AT25 x 8-12**

**Type:**

**Tubeless**



**Rear:**

**Manufacturer/model:**

**DUNLOP/KT425**

**Size:**

**AT25 x 10-12**

**Type:**

**Tubeless**

- **The tires should be set to the recommended pressure:**

**Recommended tire pressure:**

**Front:**

**35.0 kPa (0.350 kgf/cm<sup>2</sup>, 5.0 psi)**

**Rear:**

**30.0 kPa (0.300 kgf/cm<sup>2</sup>, 4.4 psi)**

- **Check and adjust tire pressures when the tires are cold.**
- **Tire pressures must be equal on both sides.**

- **Tire pressure below the minimum specified could cause the tire to dislodge from the rim under severe riding conditions.**

**Minimum tire pressure:**

**Front:**

**32.0 kPa (0.320 kgf/cm<sup>2</sup>, 4.6 psi)**

**Rear:**

**27.0 kPa (0.270 kgf/cm<sup>2</sup>, 4.0 psi)**

- **Use no more than the following pressures when seating the tire beads.**

- **Maximum tire seating pressure:**

**Front:**

**250 kPa (2.5 kgf/cm<sup>2</sup>, 36 psi)**

**Rear:**

**250 kPa (2.5 kgf/cm<sup>2</sup>, 36 psi)**

**Higher pressures and fast inflation may cause a tire to burst. Inflate the tires very slowly and carefully.**

EBU19821

## **Measuring the tire pressure**

Use the low-pressure tire gauge.

## TIP

The low-pressure tire gauge is included as standard equipment. Make two measurements of the tire pressure and use the second reading. Dust or dirt in the gauge could cause the first reading to be incorrect.

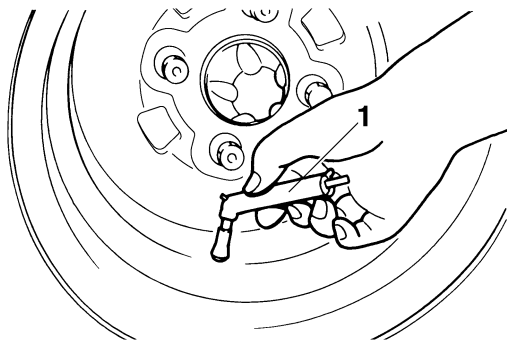

1. Low-pressure tire gauge

Set the tire pressure when the tires are cold. Set the tire pressures to the following specifications:

### Recommended pressure:

Front

35.0 kPa (0.350 kgf/cm<sup>2</sup>, 5.0 psi)

Rear

30.0 kPa (0.300 kgf/cm<sup>2</sup>, 4.4 psi)

### Minimum:

Front

32.0 kPa (0.320 kgf/cm<sup>2</sup>, 4.6 psi)

Rear

27.0 kPa (0.270 kgf/cm<sup>2</sup>, 4.0 psi)

EBU19830

### Tire wear limit

Replace the tire when the tire groove decreases to 3 mm (0.12 in).

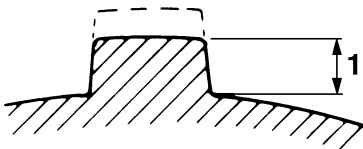

#### 1. Tire wear limit

EBU19840

### **Chassis fasteners**

Make sure that all nuts, bolts and screws are properly tightened.

EBU19850

### **Instruments, lights and switches**

Check that all instruments, lights and switches are working properly. Correct if necessary.

# OPERATION

EWB00010

## **WARNING**

Indicates a potential hazard that could result in serious injury or death.

EBU19890

EWB00610

## **WARNING**

6

### POTENTIAL HAZARD

Operating ATV without being familiar with all controls.

### WHAT CAN HAPPEN

Loss of control, which could cause an accident or injury.

### HOW TO AVOID THE HAZARD

Read the Owner's Manual carefully. If there is a control or function you do not understand, ask your Yamaha dealer.

EBU29000

## Starting the engine

EWB00620

## **WARNING**

### POTENTIAL HAZARD

Frozen control cables in cold weather.

### WHAT CAN HAPPEN

You could be unable to control the ATV, which could lead to an accident or collision.

### HOW TO AVOID THE HAZARD

When riding in cold weather, always make sure all control cables work smoothly before you begin riding.

ECB00150

## **NOTICE**

See the "Engine break-in" section on page 6-4 prior to operating the engine for the first time.

1. Turn the main switch to "ON" and the engine stop switch to "○".

**NOTICE**

**The coolant temperature warning light and engine trouble warning light should come on, then go off.**

**The EPS warning light should come on, then go off when the engine is started. (for EPS model)**

**If a warning light does not go off, see page 4-2 for the corresponding warning light circuit check.**

2. Apply the brake pedal, and then shift the drive select lever into the neutral or park position. The corresponding indicator light should come on. If the indicator light does not come on, have a Yamaha dealer check the electrical circuit.

**TIP**

This model is equipped with an ignition circuit cut-off system. The engine can be started under the following conditions:

- The drive select lever is in the neutral or park position.

- The rear brake lever or brake pedal is applied with the drive select lever in any position. However, it is recommended to shift into the neutral or park position before starting the engine.

3. Apply the rear brake lever or brake pedal.
4. Completely close the throttle lever and start the engine by pushing the start switch.

**TIP**

If the engine fails to start, release the start switch, then push it again. Pause a few seconds before the next attempt. Each cranking should be as short as possible to preserve battery energy. Do not crank the engine more than 10 seconds on each attempt.

5. Continue warming up the engine until it idles smoothly.

ECB00160

**NOTICE**

**For maximum engine life, always warm the engine up before starting off. Never accelerate hard when the engine is cold!**

## Operating the drive select lever and driving in reverse

### NOTICE

Before shifting, stop the ATV, otherwise the transmission may be damaged.

### Shifting: Neutral to High-range and High-range to Low-range

1. Bring the ATV to a complete stop.
2. Apply the brake pedal, and then shift by moving the drive select lever along the shift guide.

### TIP

Make sure that the drive select lever is completely shifted into position.

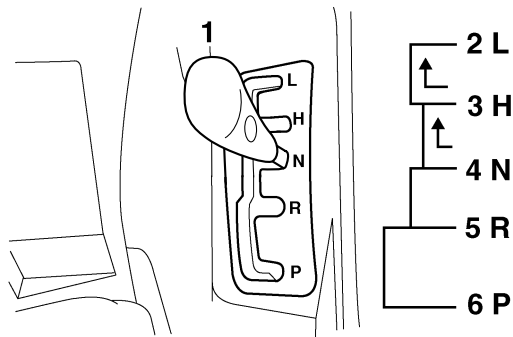

1. Drive select lever
2. L (Low-range)
3. H (High-range)
4. N (Neutral)
5. R (Reverse)
6. P (Park)

3. Release the brake pedal, and then open the throttle lever gradually.

### Shifting: Neutral to Reverse and Reverse to Park

### TIP

The drive select lever cannot be shifted into or from reverse or park without applying the brake pedal.

1. Bring the ATV to a complete stop.

2. Apply the brake pedal.
3. Shift from neutral to reverse or from reverse to park and vice versa by moving the drive select lever along the shift guide.

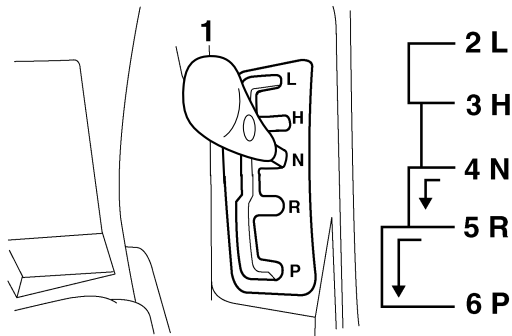

1. Drive select lever
2. L (Low-range)
3. H (High-range)
4. N (Neutral)
5. R (Reverse)
6. P (Park)

#### TIP

- When in reverse, the reverse indicator light should come on. If the indicator light does not come on, have a Yamaha dealer check the electrical circuit.

- Due to the synchronizing mechanism in the engine, the indicator light may not come on until the ATV starts moving.

4. Check behind for people or obstacles, and then release the brake pedal.
5. Open the throttle lever gradually and continue to watch to the rear while backing.

EWB00660

#### **⚠ WARNING**

##### **POTENTIAL HAZARD**

**Improperly operating in reverse.**

##### **WHAT CAN HAPPEN**

**You could hit an obstacle or even a person behind you, resulting in serious injury.**

##### **HOW TO AVOID THE HAZARD**

**When you shift into reverse, make sure there are no people or obstacles behind you.**

**When it is safe to proceed, go slowly.**

EBU20682

#### **Engine break-in**

#### TIP

- For ATVs equipped with an odometer or an hour meter, follow the figures given in km (mi) or the figures given in hours.

- For ATVs not equipped with an odometer or hour meter, follow the figures given in hours.

There is never a more important period in the life of your engine than the first 320 km (200 mi) or 20 hours of riding. For this reason, you should read the following material carefully.

Since the engine is brand new, do not put an excessive load on it for the first 320 km (200 mi) or 20 hours. The various parts in the engine wear and polish themselves to the correct operating clearances. During this period, prolonged full-throttle operation or any condition that might result in engine overheating must be avoided.

6

### **0–160 km (0–100 mi) or 0–10 hours**

Avoid prolonged operation above 1/2 throttle. Vary the speed of the ATV regularly. Do not operate it at one set throttle position.

### **160–320 km (100–200 mi) or 10–20 hours**

Avoid prolonged operation above 3/4 throttle. Rev the engine freely, but do not use full throttle at any time.

### **320 km (200 mi) or 20 hours and beyond**

The ATV can now be operated normally.

ECB00220

## **NOTICE**

**If any engine trouble should occur during the engine break-in period, immediately have a Yamaha dealer check the ATV.**

EBU27321

## **Parking**

When parking the ATV, stop the engine, and shift the drive select lever into the park position.

EBU20810

## **Parking on a slope**

EWB00780

## **WARNING**

### **POTENTIAL HAZARD**

**Parking on a hill or other incline.**

### **WHAT CAN HAPPEN**

**The ATV could roll out of control, increasing the chance of an accident.**



## HOW TO AVOID THE HAZARD

**Avoid parking on hills or other inclines. If you must park on an incline, place the ATV transversely across the incline, stop the engine, shift the drive select lever to the park position, and then block the front and rear wheels with rocks or other objects.**

**Do not park the ATV at all on hills that are so steep you could not walk up them easily.**

1. Bring the ATV to a stop by applying the brakes.
2. Stop the engine.
3. With the brake pedal applied, shift the drive select lever to the park position.

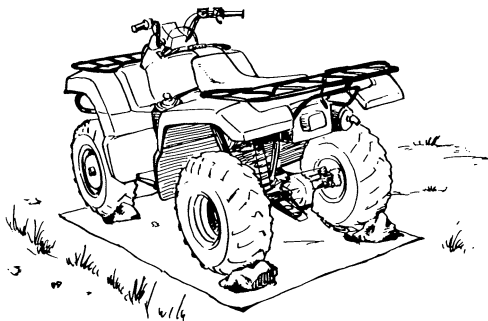

EBU20910

## Accessories and loading

EBU20920

### Accessories

Accessories can affect the handling and control of your ATV. Keep the following in mind when considering an accessory or operating an ATV which has accessories.

- Choose only accessories designed for your ATV. Your Yamaha dealer has a variety of genuine Yamaha accessories. Other accessories may also be available on the market. However, it is not possible for Yamaha to test all non-Yamaha accessories, nor control over their quality or suitability. Choose a genuine Yamaha accessory, or one that is equivalent in design and quality.
- Accessories should be rigidly and securely mounted. An accessory which can shift position or come off while you are riding could affect your ability to control the ATV.
- Do not mount an accessory where it could interfere with your ability to control the ATV. Examples include (but are not limited to) a heavy or bulky object attached to the handlebars which

could make steering difficult, an accessory that limits your ability to move around on the seat, or one that limits your view.

- Use extra caution when riding an ATV with accessories. The ATV may handle differently than it does without accessories.

EBU27560

## Loading

Cargo or a trailer can change the stability and handling of an ATV.

You must use common sense and good judgment when carrying cargo or towing a trailer. Keep the following points in mind:

- Never exceed the weight limits shown. An overloaded ATV can be unstable.

### MAXIMUM LOADING LIMIT

ATV loading limit (total weight of rider, cargo, accessories, and tongue):

220.0 kg (485 lb)

Front carrier:

45.0 kg (99 lb)

Rear carrier:

85.0 kg (187 lb)

Front storage compartment:

0.5 kg (1 lb)

Rear storage compartment:

2.0 kg (4 lb)

Trailer hitch:

Pulling load (total weight of trailer and cargo):

5880 N (600 kgf, 1322 lbf)

Tongue weight (vertical weight on trailer hitch point):

147 N (15 kgf, 33 lbf)

- Do not exceed the maximum tongue weight. You can measure tongue weight with a bathroom scale. Put the tongue of the loaded trailer on the scale with the tongue at hitch height. Adjust the load in the trailer, if necessary, to reduce

the weight on the hitch. If you are carrying cargo and towing a trailer, include the tongue weight in the maximum ATV load limit.

- Load cargo on the carriers as close to the center of the ATV as possible. Put cargo at the rear of the front carrier, at the front of the rear carrier, and center it.
- Tie down cargo securely to the carriers. Make sure cargo in the trailer cannot move around. A shifting load can cause an accident.
- Make sure the load does not interfere with controls or your ability to see where you are going.
- Ride more slowly than you would without a load. The more weight you carry, the slower you should go. Although conditions vary, it is good practice not to exceed low range whenever you are carrying heavier loads or when towing a trailer.
- Allow more braking distance. A heavier ATV takes longer to stop.
- Avoid making sharp turns unless at very slow speeds.
- Avoid hills and rough terrain. Choose terrain carefully. Added weight affects the stability and handling of the ATV.

EWB00750

 **WARNING**

**POTENTIAL HAZARD**

**Overloading this ATV or carrying or towing cargo improperly.**

**WHAT CAN HAPPEN**

**Could cause changes in ATV handling which could lead to an accident.**

**HOW TO AVOID THE HAZARD**

**Never exceed the stated load capacity for this ATV.**

**Cargo should be properly distributed and securely attached.**

**Reduce speed when carrying cargo or pulling a trailer. Allow greater distance for braking.**

EWB00010

 **WARNING**

**Indicates a potential hazard that could result in serious injury or death.**

# RIDING YOUR ATV

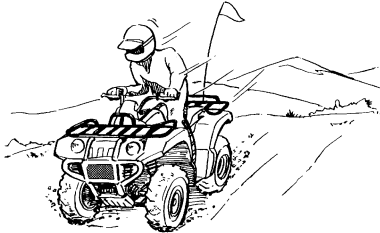
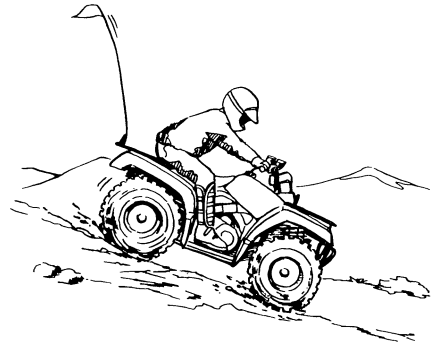
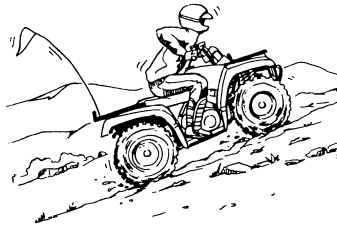
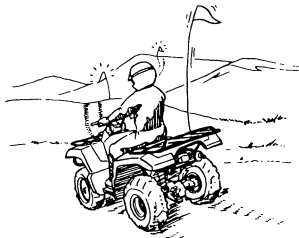

7

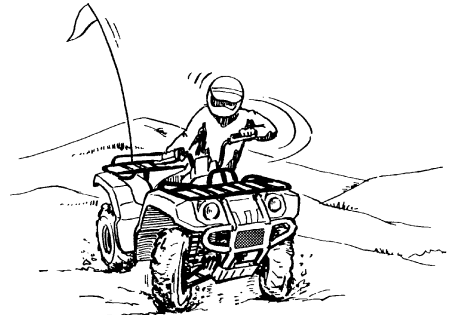



**Indicates a potential hazard that could result in serious injury or death.**

EBU27393

## **GETTING TO KNOW YOUR ATV**

This ATV is mainly for utility use, but may also be used for recreation. This section, Riding your ATV, provides general ATV riding instructions for recreational riding. The skills and techniques described in this section, however, are appropriate for all types of riding. Riding your ATV requires special skills acquired through practice over a period of time. Take the time to learn the basic techniques well before attempting more difficult maneuvers.

Riding your new ATV can be a very enjoyable activity, providing you with hours of pleasure. But it is essential to familiarize yourself with the operation of the ATV to achieve the skill necessary to enjoy riding safely. Before you begin to ride, be sure you have read this Owner's Manual completely and understand the operation of the controls. Pay partic-

ular attention to the safety information on pages 1-1-1-4. Please also read all notice and warning labels on your ATV.

## RIDE WITH CARE AND GOOD JUDGEMENT

### Get training if you are inexperienced.

Beginners should get training from a certified instructor.

Become familiar with this ATV at slow speeds first, even if you are an experienced operator. Do not attempt to operate at maximum performance until you are totally familiar with the ATV's handling and performance characteristics.

EWB01280

### **WARNING**

#### POTENTIAL HAZARD

**Operating this ATV without proper instruction.**

#### WHAT CAN HAPPEN

**The risk of an accident is greatly increased if the operator does not know how to operate the ATV properly in different situations and on different types of terrain.**

7

## HOW TO AVOID THE HAZARD

**Beginning and inexperienced operators should complete the certified training course offered by Yamaha. They should then regularly practice the skills learned in the course and the operating techniques described in this Owner's Manual. For more information about the training course, contact an authorized ATV dealer or call 1-800-887-2887.**

**Riding your ATV requires skills acquired through practice over a period of time.**

Take the time to learn the basic techniques well before attempting more difficult maneuvers.

**Not recommended for children under 16 years of age.**

EWB00901

### **WARNING**

#### POTENTIAL HAZARD

**Failure to follow the age recommendations for this ATV.**

**WHAT CAN HAPPEN**

Use by children of ATVs that are not recommended for their age can lead to severe injury or death of the child.

**HOW TO AVOID THE HAZARD**

A child under 16 should never operate an ATV with engine size greater than 90 cc.



This ATV is designed to carry operator and cargo only – passengers prohibited.

EWB00910

**⚠ WARNING**

**POTENTIAL HAZARD**

Carrying a passenger on this ATV.

**WHAT CAN HAPPEN**

Greatly reduces your ability to balance and control this ATV. Could cause an accident, resulting in harm to you and/or your passenger.

**HOW TO AVOID THE HAZARD**

Never carry a passenger. The long seat is to allow the operator to shift position as needed during operation. It is not for carrying passengers.

7

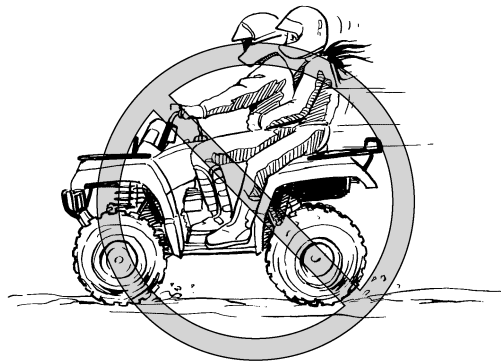



## Apparel

EWB00920

### WARNING

#### POTENTIAL HAZARD

Operating this ATV without wearing an approved motorcycle helmet, eye protection and protective clothing.

#### WHAT CAN HAPPEN

Operating without an approved motorcycle helmet increases your chances of a severe head injury or death in the event of an accident.

Operating without eye protection can result in an accident and increases your chances of a severe injury in the event of an accident. Operating without protective clothing increases your chances of severe injury in the event of an accident.

## HOW TO AVOID THE HAZARD

Always wear an approved motorcycle helmet that fits properly.

You should also wear:

- eye protection (goggles or face shield)
- gloves
- boots
- long-sleeved shirt or jacket
- long pants

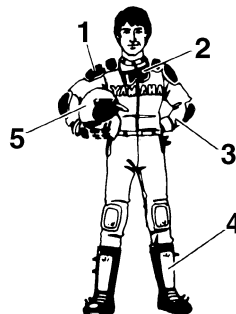

1. Protective clothing
2. Goggles
3. Gloves
4. Boots
5. Helmet

**Do not operate after consuming alcohol or drugs.**

The operator's performance capability is reduced by the influence of alcohol or drugs.



7

EWB00930

**⚠ WARNING**

**POTENTIAL HAZARD**

Operating this ATV after consuming alcohol or drugs.

**WHAT CAN HAPPEN**

Could seriously affect your judgment.  
Could cause you to react more slowly.  
Could affect your balance and perception.  
Could result in an accident.

**HOW TO AVOID THE HAZARD**

**Never consume alcohol or drugs before or while driving this ATV.**

**Pre-operation checks**

Always perform the pre-operation checks listed on page 5-1 before riding for proper care of the ATV and to ensure safety.

EWB00940

**⚠ WARNING**

**POTENTIAL HAZARD**

Failure to inspect the ATV before operating.  
Failure to properly maintain the ATV.

**WHAT CAN HAPPEN**

Increases the possibility of an accident or equipment damage.

**HOW TO AVOID THE HAZARD**

Always inspect your ATV each time you use it to make sure the ATV is in safe operating condition.

Always follow the inspection and maintenance procedures and schedules described in the Owner's Manual.

**⚠ WARNING****POTENTIAL HAZARD**

Operating this ATV with improper tires, or with improper or uneven tire pressure.

**WHAT CAN HAPPEN**

Use of improper tires on this ATV, or operation of this ATV with improper or uneven tire pressure, may cause loss of control, increasing your risk of an accident.

**HOW TO AVOID THE HAZARD**

Always use the size and type tires specified in the Owner's Manual for this ATV on page 5-6.

Always maintain proper tire pressure as described in the Owner's Manual on page 5-7.

**⚠ WARNING**

Indicates a potential hazard that could result in serious injury or death.

Do not operate at speeds too fast for your skills or the conditions.

**⚠ WARNING****POTENTIAL HAZARD**

Operating this ATV at speeds too fast for your skills or the conditions.

**WHAT CAN HAPPEN**

Increases your chances of losing control of the ATV, which can result in an accident.

**HOW TO AVOID THE HAZARD**

Always go at a speed that is proper for the terrain, visibility and operating conditions, and your experience.

## Speed limiter

For riders less experienced with this model, the throttle lever housing is equipped with a speed limiter. The speed limiter keeps the throttle from fully opening, even when the throttle lever is pushed to the maximum. Turning in the adjusting screw limits the maximum engine power available and decreases the maximum speed of the ATV. Turning in the adjusting screw decreases top speed, and turning it out increases top speed. (See page 4-14.)

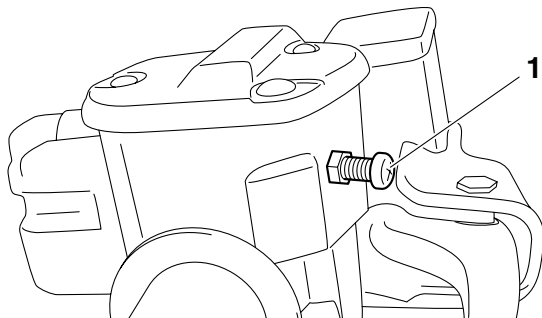

1. Adjusting screw

## Loading and accessories

Use extra caution when riding the ATV with additional loads, such as accessories or cargo. The ATV's handling may be adversely affected. Reduce your speed when adding additional loads.

### MAXIMUM LOADING LIMIT

ATV loading limit (total weight of cargo, rider, accessories, and tongue):

220.0 kg (485 lb)

Front carrier:

45.0 kg (99 lb)

Rear carrier:

85.0 kg (187 lb)

Front storage compartment:

0.5 kg (1 lb)

Rear storage compartment:

2.0 kg (4 lb)

Trailer hitch:

Pulling load (total weight of trailer and cargo):

5880 N (600 kgf, 1322 lbf)

Tongue weight (vertical weight on trailer hitch point):

147 N (15 kgf, 33 lbf)

**WARNING****POTENTIAL HAZARD**

Overloading this ATV or carrying or towing cargo improperly.

**WHAT CAN HAPPEN**

Could cause changes in ATV handling which could lead to an accident.

**HOW TO AVOID THE HAZARD**

Never exceed the stated load capacity for this ATV.

Cargo should be properly distributed and securely attached.

Reduce speed when carrying cargo or pulling a trailer. Allow greater distance for braking.

Always follow the instructions in your Owner's Manual for carrying cargo or pulling a trailer.

## **During operation**

Always keep your feet on the footboards during operation, otherwise they may contact the rear wheels.

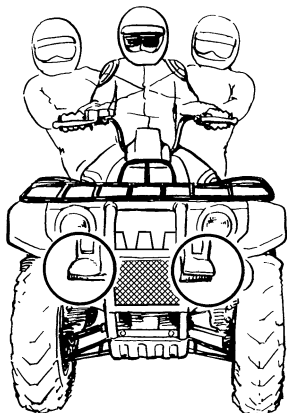

7

EWB00980

### **⚠ WARNING**

#### **POTENTIAL HAZARD**

Removing hands from handlebars or feet from footboards during operation.

## **WHAT CAN HAPPEN**

Removing even one hand or foot can reduce your ability to control the ATV or could cause you to lose your balance and fall off of the ATV. If you remove a foot from a footboard, your foot or leg may come into contact with the rear wheels, which could injure you or cause an accident.

## **HOW TO AVOID THE HAZARD**

Always keep both hands on the handlebars and both feet on the footboards of your ATV during operation.

Avoid wheelies and jumping. You may lose control of the ATV or overturn.

EWB00990

### **⚠ WARNING**

#### **POTENTIAL HAZARD**

Attempting wheelies, jumps, and other stunts.

## **WHAT CAN HAPPEN**

Increases the chance of an accident, including an overturn.

## **HOW TO AVOID THE HAZARD**

Never attempt stunts, such as wheelies or jumps. Don't try to show off.

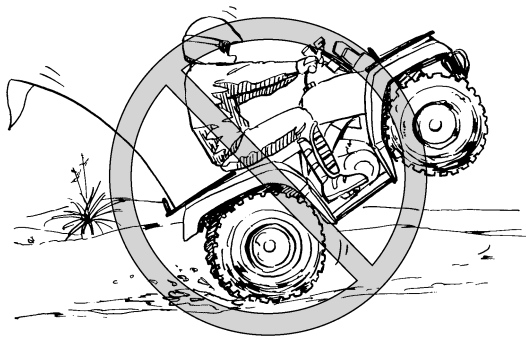

### HOW TO AVOID THE HAZARD

Never modify this ATV through improper installation or use of accessories. All parts and accessories added to this ATV should be genuine Yamaha or equivalent components designed for use on this ATV and should be installed and used according to instructions. If you have questions, consult an authorized ATV dealer.

### **Modifications**

EWB01000

#### **⚠ WARNING**

#### **POTENTIAL HAZARD**

Operating this ATV with improper modifications.

#### **WHAT CAN HAPPEN**

Improper installation of accessories or modification of this ATV may cause changes in handling which in some situations could lead to an accident.

## Exhaust system

The exhaust system on the ATV is very hot during and following operation. To prevent burns, avoid touching the exhaust system. Park the ATV in a place where pedestrians or children are not likely to touch it.

EWB01010

### **WARNING**

#### **POTENTIAL HAZARD**

**Hot exhaust system.**

#### **WHAT CAN HAPPEN**

Dry grass or brush or other combustible material accumulated around the engine area could catch fire.

Someone touching the exhaust system during or after operation could be burned.

#### **HOW TO AVOID THE HAZARD**

Do not operate, idle, or park the ATV in dry grass or other dry ground cover.

Keep the engine area free of dry grass, brush, or other combustible material.

Do not touch the hot exhaust system.

Do not park the ATV in a place where others might be likely to touch it.

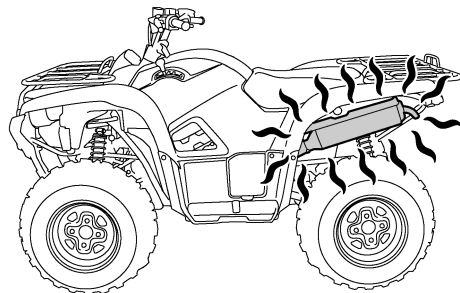

## **BE CAREFUL WHERE YOU RIDE**

This ATV is designed for off-road use only. Riding on paved surfaces can cause loss of control.

EWB01020

### **WARNING**

#### **POTENTIAL HAZARD**

**Operating this ATV on paved surfaces.**

#### **WHAT CAN HAPPEN**

ATVs are designed for off-road use only. Paved surfaces may seriously affect handling and control of the ATV, and may cause the ATV to go out of control.



## HOW TO AVOID THE HAZARD

Always avoid paved surfaces, including sidewalks, driveways, parking lots and streets.

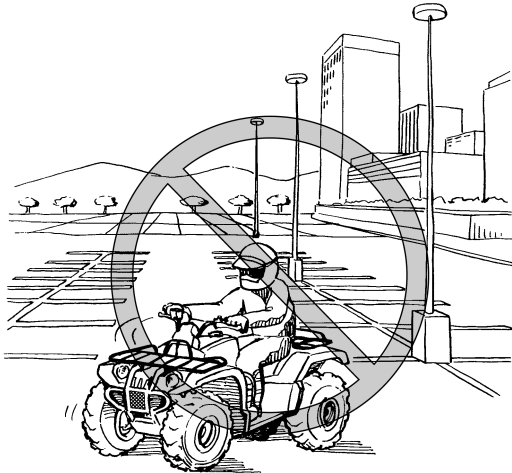

Do not ride on any public road, street, or highway. Riding on public roads can result in collisions with other vehicles.

EWB01030

## **WARNING**

### POTENTIAL HAZARD

Operating this ATV on public streets, roads or highways.

### WHAT CAN HAPPEN

You can collide with another vehicle.

### HOW TO AVOID THE HAZARD

Never operate this ATV on any public street, road or highway, even a dirt or gravel one. In many states it is illegal to operate ATVs on public streets, roads and highways.

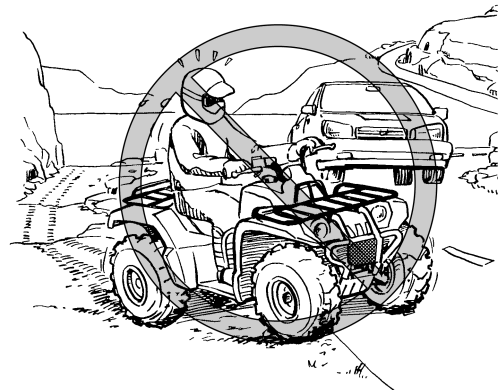

Know the terrain where you ride. Ride cautiously in unfamiliar areas. Stay alert for **holes, rocks, or roots** in the terrain, and **other hidden hazards** which may cause the ATV to upset.

EWB01040

**⚠ WARNING**

**POTENTIAL HAZARD**

Failure to use extra care when operating this ATV on unfamiliar terrain.

**WHAT CAN HAPPEN**

You can come upon hidden rocks, bumps, or holes, without enough time to react. Could result in the ATV overturning or going out of control.

**HOW TO AVOID THE HAZARD**

Go slowly and be extra careful when operating on unfamiliar terrain. Always be alert to changing terrain conditions when operating the ATV.



EWB01050

**⚠ WARNING**

**POTENTIAL HAZARD**

Failure to use extra care when operating on excessively rough, slippery or loose terrain.

**WHAT CAN HAPPEN**

Could cause loss of traction or ATV control, which could result in an accident, including an overturn.

## **HOW TO AVOID THE HAZARD**

**Do not operate on excessively rough, slippery or loose terrain until you have learned and practiced the skills necessary to control the ATV on such terrain. Always be especially cautious on these kinds of terrain.**

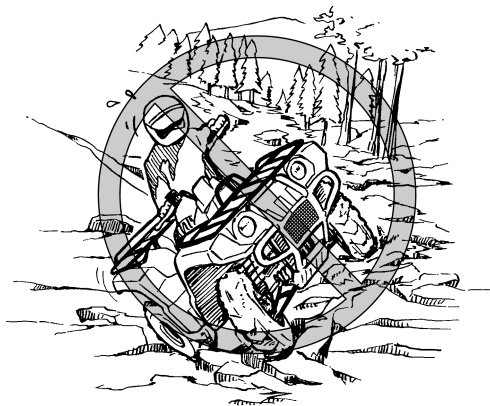

When riding in an area where you might not easily be seen, such as desert terrain, mount a caution flag on the ATV. DO NOT use the flag pole bracket as a trailer hitch.

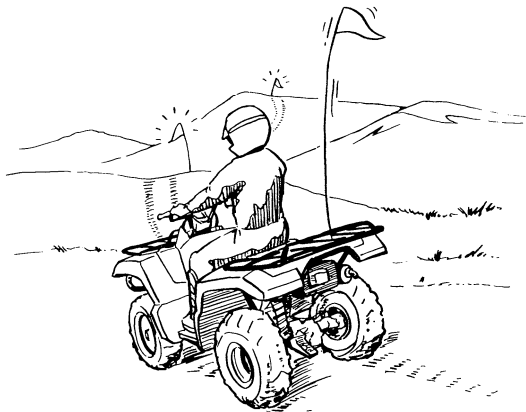

7

EWB01060

**WARNING**

**POTENTIAL HAZARD**

**Operating in areas where you might not be seen by other off-road vehicles.**

**WHAT CAN HAPPEN**

**You could be in a collision. You could be injured.**

**HOW TO AVOID THE HAZARD**

**Always mount a caution flag on the ATV to make you more visible. Watch carefully for other vehicles.**

Do not ride in areas posted “no trespassing”. Do not ride on private property without getting permission.

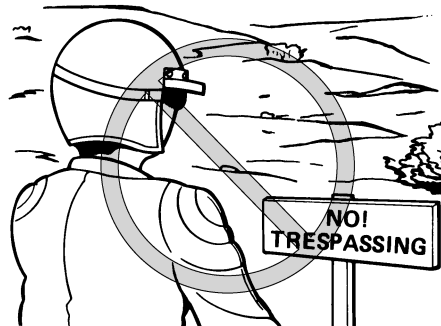

Select a large, flat area off-road to become familiar with your ATV. Make sure that this area is free of obstacles and other riders. You should practice control of the throttle, brakes, shifting procedures, and turning techniques in this area before trying more difficult terrain. Always avoid riding on paved

**NOTICE**

---

**Do not shift from drive position low-range to high-range or vice versa without coming to a complete stop. Damage to the engine or drive train may occur.**

---

surfaces: the ATV is designed for off-road use only, and handling maneuvers are more difficult to perform on pavement.

Shift to the park position and follow the instruction on page 6-1 to start the engine. Once it has warmed up you are ready to begin riding your ATV. Remember that the engine and exhaust pipe will be hot when riding and afterwards; do not allow skin or clothing to come in contact with these components.

With the engine idling, shift the drive select lever into the low-range position or the high-range position. Apply the throttle slowly and smoothly. The centrifugal clutch will engage and you will start to accelerate. If the throttle is applied too abruptly, the front wheels may lift off the ground, resulting in a loss of directional control. Avoid higher speeds until you are thoroughly familiar with the operation of your ATV.

When slowing down or stopping, release the throttle and apply the brakes smoothly and evenly. Improper use of the brakes can cause the tires to lose traction, reducing control and increasing the possibility of an accident.

## TURNING YOUR ATV

To achieve maximum traction while riding off-road in 2WD or 4WD, the two rear wheels turn together at the same speed. Furthermore, when riding in 4WD-LOCK (“DIFF. LOCK”), the front wheels also turn together at the same speed. Therefore, unless the wheel on the inside of the turn is allowed to slip or lose some traction, the ATV will resist turning. A special turning technique must be used to allow the ATV to make turns quickly and easily. It is essential that this skill be learned first at low speed.

EWB01310



### WARNING

#### **POTENTIAL HAZARD**

**Turning improperly.**

#### **WHAT CAN HAPPEN**

**ATV could go out of control, causing a collision or overturn.**

## HOW TO AVOID THE HAZARD

**Always follow proper procedures for turning as described in this Owner’s Manual. Practice turning at low speeds before attempting to turn at faster speeds. Do not turn at speeds too fast for your skills or the conditions. Operate at a slow speed and allow extra time and distance for maneuvers when in 4WD-LOCK (“DIFF. LOCK”).**

As you approach a curve, slow down and begin to turn the handlebars in the desired direction. As you do so, put your weight on the footboard to the outside of the turn (opposite your desired direction) and lean your upper body into the turn. Use the throttle to maintain an even speed through the turn. This maneuver will let the wheel on the inside of the turn slip slightly, allowing the ATV to make the turn properly.

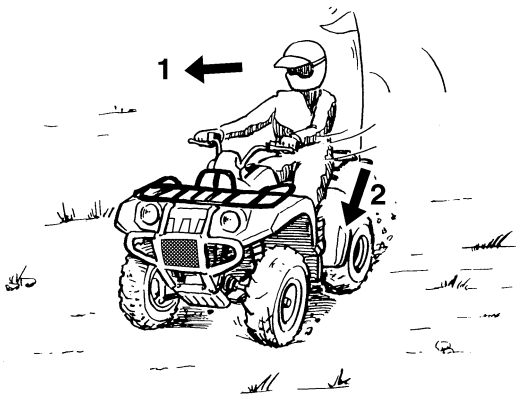

1. Lean towards inside of turn.
2. Support your weight on the outer footboard.

This procedure should be practiced at slow speed many times in a large off-road area with no obstacles. If an incorrect technique is used, your ATV may continue to go straight. If the ATV doesn't turn, come to a stop and then practice the procedure again. If the riding surface is slippery or loose, it may help to position more of your weight over the front wheels by moving forward on the seat.

Once you have learned this technique, you should be able to perform it at higher speeds or in tighter curves.

Improper riding procedures such as abrupt throttle changes, excessive braking, incorrect body movements, or too much speed for the sharpness of the turn may cause the ATV to tip. If the ATV begins to tip over to the outside while negotiating a turn, lean more to the inside. It may also be necessary to gradually let off on the throttle and steer to the outside of the turn to avoid tipping over. Remember: Avoid higher speeds until you are thoroughly familiar with the operation of your ATV.

## CLIMBING UPHILL

Use proper riding techniques to avoid ATV over- turns on hills. Be sure that you can maneuver your ATV well on flat ground before attempting any incline and then practice riding first on gentle slopes. Try more difficult climbs only after you have developed your skill. In all cases avoid inclines with slip- pery or loose surfaces, or obstacles that might cause you to lose control.

EWB01090



### WARNING

#### POTENTIAL HAZARD

**Operating on excessively steep hills.**

#### WHAT CAN HAPPEN

The ATV can overturn more easily on ex- tremely steep hills than on level surfaces or small hills.

#### HOW TO AVOID THE HAZARD

Never operate the ATV on hills too steep for the ATV or for your abilities. Practice on smaller hills before attempting large hills.

It is important when climbing a hill to make sure that your weight is transferred forward on the ATV. This can be accomplished by leaning forward and, on steeper inclines, standing on the footboards and leaning forward over the handlebars.

EWB01180



### WARNING

#### POTENTIAL HAZARD

**Climbing hills improperly.**

#### WHAT CAN HAPPEN

Could cause loss of control or cause the ATV to overturn.

#### HOW TO AVOID THE HAZARD

Always follow proper procedures for climb- ing hills as described in this Owner's Manu- al.

Always check the terrain carefully before you start up any hill.

Never climb hills with excessively slippery or loose surfaces.

Shift your weight forward.

Never open the throttle suddenly. The ATV could flip over backwards.

Never go over the top of any hill at high speed. An obstacle, a sharp drop, or another vehicle or person could be on the other side of the hill.



OK

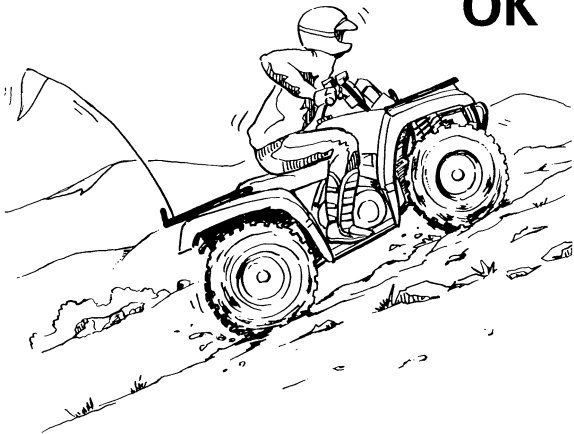

If you are climbing a hill and you find that you have not properly judged your ability to make it to the top, you should turn the ATV around while you still have forward motion (provided you have the room to do so) and go down the hill.

EWB01190

**⚠ WARNING**

**POTENTIAL HAZARD**

**Improperly crossing hills or turning on hills.**

**WHAT CAN HAPPEN**

**Could cause loss of control or cause the ATV to overturn.**

**HOW TO AVOID THE HAZARD**

**Never attempt to turn the ATV around on any hill until you have mastered the turning technique as described in the Owner's Manual on level ground. Be very careful when turning on any hill.**

**Avoid crossing the side of a steep hill if possible.**

**When crossing the side of a hill:**

**Always follow proper procedures as described in the Owner's Manual.**

**Avoid hills with excessively slippery or loose surfaces.**

**Shift your weight to the uphill side of the ATV.**

**OK**

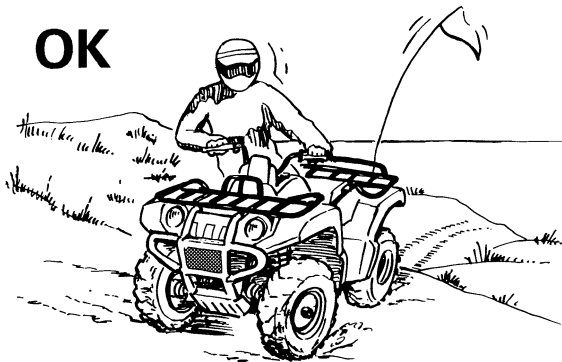

If your ATV has stalled or stopped and you believe you can continue up the hill, restart carefully to make sure you do not lift the front wheels which could cause you to lose control. If you are unable to continue up the hill, dismount the ATV on the uphill side. Physically turn the ATV around and then descend the hill.

If you start to roll backwards, DO NOT apply either brake abruptly. If you are in 2WD, apply only the front brake. If you are in 4WD or 4WD-LOCK, because all wheels are interconnected by the drive train, applying either brake will brake all wheels, therefore, avoid sudden application of either the front or rear brake as the wheels on the uphill side could come off the ground. The ATV could easily tip over backwards. Apply both the front and rear brakes gradually, or dismount the ATV immediately on the uphill side.

EWB01351

**⚠ WARNING**

**POTENTIAL HAZARD**

**Stalling, rolling backwards or improperly dismounting while climbing a hill.**

**WHAT CAN HAPPEN**

**Could result in ATV overturning.**

**HOW TO AVOID THE HAZARD**

**Use the proper gear and maintain a steady speed when climbing a hill.**

**If you lose all forward speed:**

- **Keep weight uphill.**
- **Apply the brakes.**
- **Shift to the park position after you are stopped.**

**If you begin rolling backwards:**

- **Keep weight uphill.**
- **2WD: Never apply the rear brake while rolling backwards. Apply the front brake.**
- **4WD or 4WD-LOCK: Apply both front and rear brakes gradually.**
- **When fully stopped, shift to the park position.**

**Dismount on uphill side or to a side if pointed straight uphill. Turn the ATV around and remount, following the procedure described in the Owner's Manual.**

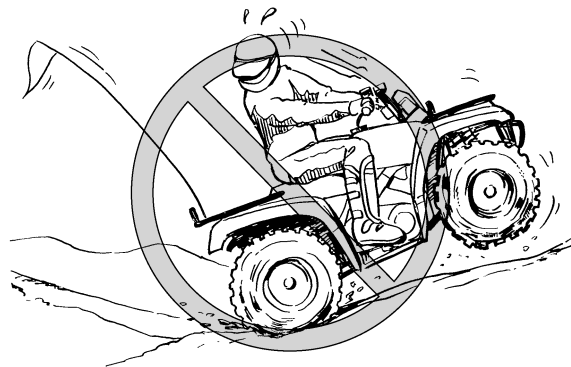

## RIDING DOWNHILL

When riding your ATV downhill, shift your weight as far to the rear and uphill side of the ATV as possible. Move back on the seat and sit with your arms straight. Engine compression will do most of the braking for you. For maximum engine compression braking effect, select the low-range position and change to 4WD or 4WD-LOCK before beginning to descend the hill. Improper braking may cause a loss of traction.

Use caution while descending a hill with loose or slippery surfaces. Braking ability and traction may be adversely affected by these surfaces. Improper braking may also cause a loss of traction.

When this ATV is in 4WD or 4WD-LOCK, all wheels (front and rear) are interconnected by the drive train. This means that applying either the front brake or the rear brake will brake all wheels. When descending hills, using either brake lever or the brake pedal will brake the wheels on the downhill side. Avoid sudden application of either the front or rear brake because the wheels on the uphill side could come off the ground. Apply both the front and rear brakes gradually.

Whenever possible, ride your ATV straight downhill. Avoid sharp angles which could allow the ATV to tip or roll over. Carefully choose your path and ride no faster than you will be able to react to obstacles which may appear.

EWB01130

### **WARNING**

#### **POTENTIAL HAZARD**

**Going down a hill improperly.**

#### **WHAT CAN HAPPEN**

**Could cause loss of control or cause the ATV to overturn.**

#### **HOW TO AVOID THE HAZARD**

**Always follow proper procedures for going down hills as described in this Owner's Manual.**

**Note: a special technique is required when braking as you go down a hill.**

**Always check the terrain carefully before you start down any hill.**

**Shift your weight backward.**

**Never go down a hill at high speed.**

**Avoid going down a hill at an angle that would cause the ATV to lean sharply to one side. Go straight down the hill where possible.**

OK



## CROSSING A SLOPE

Traversing a sloping surface on your ATV requires you to properly position your weight to maintain proper balance. Be sure that you have learned the basic riding skills on flat ground before attempting to cross a sloping surface. Avoid slopes with slippery surfaces or rough terrain that may upset your balance.

As you travel across a slope, lean your body in the uphill direction. It may be necessary to correct the steering when riding on loose surfaces by pointing the front wheels slightly uphill. When riding on slopes, be sure not to make sharp turns either up or down hill.

If your ATV does begin to tip over, gradually steer in the downhill direction if there are no obstacles in your path. As you regain proper balance, gradually steer again in the direction you wish to travel.

EWB01141



### **WARNING**

#### **POTENTIAL HAZARD**

**Improperly crossing hills or turning on hills.**

#### **WHAT CAN HAPPEN**

**Could cause loss of control or cause the ATV to overturn.**

## HOW TO AVOID THE HAZARD

**Never attempt to turn the ATV around on any hill until you have mastered the turning technique as described in the Owner's Manual on level ground. Be very careful when turning on any hill. Avoid crossing the side of a steep hill if possible.**

### **When crossing the side of a hill:**

**Always follow proper procedures as described in the Owner's Manual.**

**Avoid hills with excessively slippery or loose surfaces.**

**Shift your weight to the uphill side of the ATV.**

OK



## CROSSING THROUGH SHALLOW WATER

The ATV can be used to cross slow moving, shallow water of up to a maximum of 35 cm (14 in) in depth. Before entering the water, choose your path carefully. Enter where there is no sharp drop off, and avoid rocks or other obstacles which may be slippery or upset the ATV. Drive slowly and carefully.

EWB01150

### WARNING

#### POTENTIAL HAZARD

Operating this ATV through deep or fast flowing water.

#### WHAT CAN HAPPEN

Tires may float, causing loss of traction and loss of control, which could lead to an accident.

#### HOW TO AVOID THE HAZARD

Never operate this ATV in fast flowing water or in water deeper than that specified in your Owner's Manual.

Remember that wet brakes may have reduced stopping ability. Test your brakes after leaving water. If necessary, apply them several times to let friction dry out the linings.

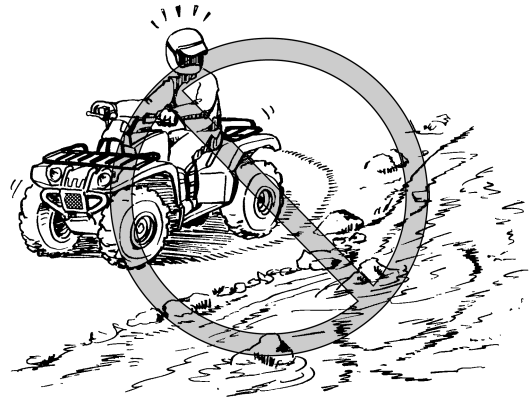

Test your brakes after leaving the water. Do not continue to ride your ATV without verifying that you have regained proper braking ability.



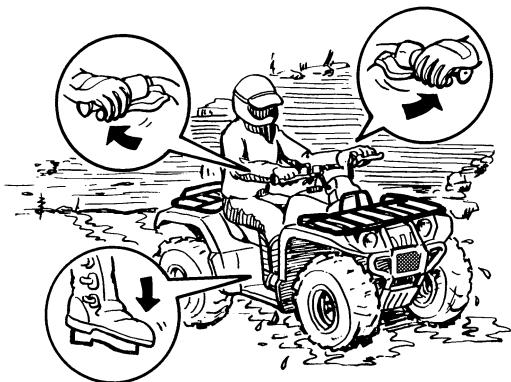

ECB00840

**NOTICE**

After riding your ATV in water, be sure to drain the trapped water by removing the check hoses at the bottom of the air filter case. Also, remove the drain plugs from the front and rear storage compartments and the V-belt case to drain any water that may have accumulated. Wash the ATV with fresh water if it has been operated in salt water or muddy conditions.

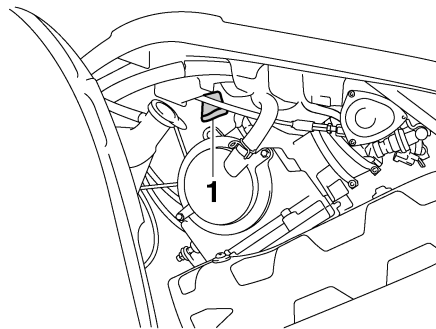

1. Air filter case check hose

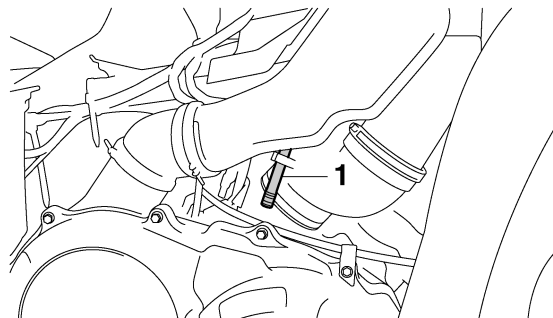

1. Air filter case check hose

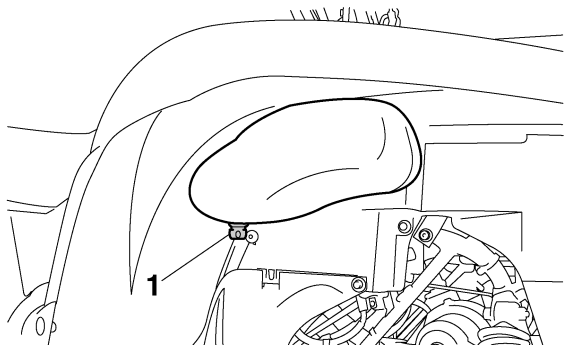

1. Storage compartment drain plug

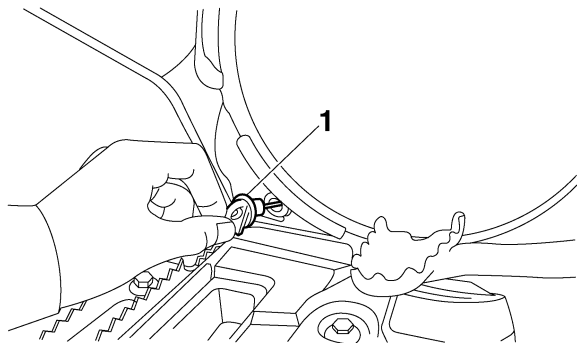

1. V-belt case drain plug

7

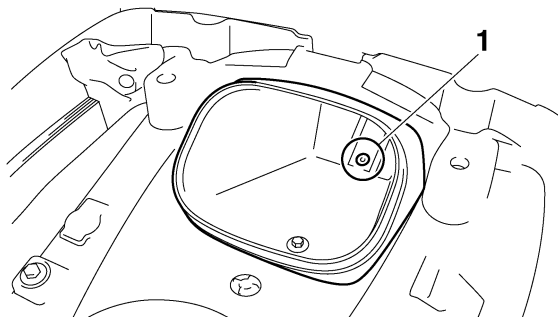

1. Storage compartment drain plug

## RIDING OVER ROUGH TERRAIN

Riding over rough terrain should be done with caution. Look out for obstacles which could cause damage to the ATV or could lead to an upset or accident. Be sure to keep your feet firmly mounted on the footboards at all times. Avoid jumping the ATV as loss of control and damage to the ATV may result.

EWB01160

**⚠ WARNING**

**POTENTIAL HAZARD**

**Improperly operating over obstacles.**

### **WHAT CAN HAPPEN**

Could cause loss of control or a collision.

Could cause the ATV to overturn.

### **HOW TO AVOID THE HAZARD**

Before operating in a new area, check for obstacles.

Never attempt to ride over large obstacles, such as large rocks or fallen trees. When you go over obstacles, always follow proper procedures as described in the Owner's Manual.

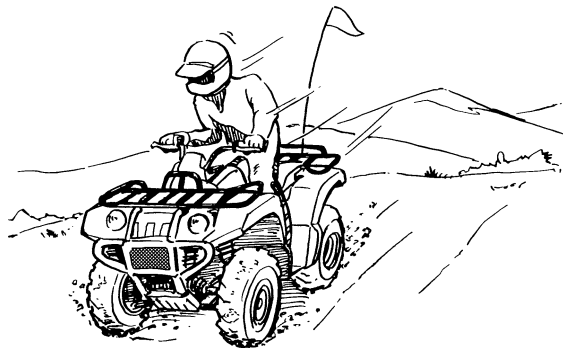

### **SLIDING AND SKIDDING**

Care should be used when riding on loose or slippery surfaces since the ATV may slide. If unexpected and uncorrected, sliding could lead to an accident.

To reduce the tendency for the front wheels to slide in loose or slippery conditions, positioning your weight over the front wheels will sometimes help.

If the rear wheels of your ATV start to slide sideways, control can usually be regained (if there is room to do so) by steering in the direction of the slide. Applying the brakes or accelerating is not recommended until you have corrected the slide.

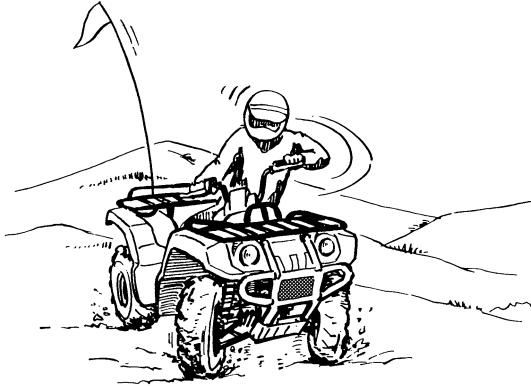

With practice, over a period of time, skill at controlled sliding can be developed. The terrain should be chosen carefully before attempting such maneuvers, since both stability and control are reduced. Bear in mind that sliding maneuvers should always be avoided on extremely slippery surfaces such as ice, since all control may be lost.

EWB01170

## **WARNING**

### **POTENTIAL HAZARD**

**Skidding or sliding improperly.**

### **WHAT CAN HAPPEN**

**You may lose control of this ATV. You may also regain traction unexpectedly, which may cause the ATV to overturn.**

### **HOW TO AVOID THE HAZARD**

**Learn to safely control skidding or sliding by practicing at low speeds and on level, smooth terrain.**

**On extremely slippery surfaces, such as ice, go slowly and be very cautious in order to reduce the chance of skidding or sliding out of control.**

### **WHAT TO DO IF...**

This section is designed to be a reference guide only. Be sure to read each section on riding techniques completely.

## WHAT TO DO...

- If your ATV doesn't turn when you want it to:  
Bring the ATV to a stop and practice the turning maneuvers again. Be sure you are putting your weight on the footboard to the outside of the turn. Position your weight over the front wheels for better control. (See page 7-19.)
- If your ATV begins to tip while turning:  
Lean more into the turn to regain balance. If necessary, gradually let off the throttle and/or steer to the outside of the turn. (See page 7-19.)
- If your ATV starts to slide sideways:  
Steer in the direction of the slide if you have the room. Applying the brakes or accelerating is not recommended until you have corrected the slide. (See page 7-32.)
- If your ATV can't make it up a hill you are trying to climb:  
Turn the ATV around if you still have forward speed. If not, stop, dismount on the uphill side of the ATV and physically turn the ATV around. If the ATV starts to slip backwards, **DO NOT USE THE REAR BRAKE IF THE ATV IS IN 2WD** – the ATV may tip over on top of you. Dismount the ATV on the uphill side. (See page 7-21.)

- If your ATV is traversing a sloping surface:  
Be sure to ride with your weight positioned towards the uphill side of the ATV to maintain proper balance. If the ATV starts to tip, steer down the hill (if there are no obstacles in your way) to regain balance. If you discover that the ATV is going to tip over, dismount on the uphill side. (See page 7-27.)
- If your ATV encounters shallow water:  
Ride slowly and carefully through slow moving water, watching for obstacles. Be sure to let water drain from the ATV and **CHECK YOUR BRAKES FOR PROPER OPERATION** when you come out of the water. Do not continue to ride your ATV until you have regained adequate braking ability. (See page 7-29.)

EWB00010



**Indicates a potential hazard that could result in serious injury or death.**

## PERIODIC MAINTENANCE AND MINOR REPAIR

Safety is an obligation of the owner. Periodic inspection, adjustment and lubrication will keep your ATV in the safest and best operating condition possible. The most important points of inspection, adjustment, and lubrication are explained on the following pages.

The intervals given in the periodic maintenance and lubrication chart should be considered as a general guide under normal riding conditions. However, **DEPENDING ON THE WEATHER, TERRAIN, GEOGRAPHICAL LOCATION, AND INDIVIDUAL USE, THE MAINTENANCE INTERVALS MAY NEED TO BE SHORTENED.**



### WARNING

#### POTENTIAL HAZARD

**Servicing an engine while it is running.**

#### WHAT CAN HAPPEN

**Moving parts can catch clothing or parts of the body, causing injury.**

**Electrical components can cause shocks or start fires.**

#### HOW TO AVOID THE HAZARD

**Turn off the engine when performing maintenance unless otherwise specified. Have a Yamaha dealer perform the service if you are not familiar with maintenance work.**

### Owner's manual and tool kit

Be sure to put this owner's manual in the plastic bag and to always carry it as well as the owner's tool kit and the low-pressure tire gauge in their respective compartments under the seat.

**⚠ WARNING****POTENTIAL HAZARD**

Operating this ATV with improper modifications.

**WHAT CAN HAPPEN**

Improper installation of accessories or modification of this ATV may cause changes in handling which in some situations could lead to an accident.

**HOW TO AVOID THE HAZARD**

Never modify this ATV through improper installation or use of accessories. All parts and accessories added to this ATV should be genuine Yamaha or equivalent components designed for use on this ATV and should be installed and used according to instructions. If you have questions, consult an authorized Yamaha ATV dealer.

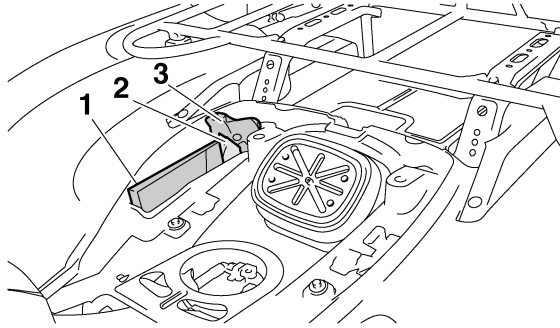

1. Owner's manual
2. Low-pressure tire gauge
3. Owner's tool kit

The service information included in this manual and the tools provided in the owner's tool kit are intended to assist you in the performance of preventive maintenance and minor repairs. However, additional tools such as a torque wrench may be necessary to perform certain maintenance work correctly.

**TIP**

If you do not have the tools or experience required for a particular job, have a Yamaha dealer perform it for you.

## Periodic maintenance chart for the emission control system

### TIP

- For ATVs not equipped with an odometer or an hour meter, follow the month maintenance intervals.
- For ATVs equipped with an odometer or an hour meter, follow the km (mi) or hours maintenance intervals. However, keep in mind that if the ATV isn't used for a long period of time, the month maintenance intervals should be followed.
- Items marked with an asterisk should be performed by a Yamaha dealer as they require special tools, data and technical skills.

NO.	ITEM	CHECK OR MAINTENANCE JOB	Whichever comes first ⇒	INITIAL			EVERY		
				month	1	3	6	6	12
				km (mi)	320 (200)	1300 (800)	2500 (1600)	2500 (1600)	5000 (3200)
				hours	20	80	160	160	320
1	* Fuel line	• Check fuel hoses for cracks or other damage, and replace if necessary.			√	√	√		
2	Spark plug	• Check condition and clean, regap, or replace if necessary.	√	√	√	√	√		
3	* Valves	• Check valve clearance and adjust if necessary.	√		√	√	√		
4	* Crankcase breather system	• Check breather hose for cracks or other damage, and replace if necessary.			√	√	√		
5	* Exhaust system	• Check for leakage and replace gasket(s) if necessary. • Check for looseness and tighten all screw clamps and joints if necessary.			√	√	√		
6	Spark arrester	• Clean.			√	√	√		



## General maintenance and lubrication chart

NO.	ITEM	CHECK OR MAINTENANCE JOB	Whichever comes first →	INITIAL			EVERY		
				month	1	3	6	6	12
				km (mi)	320 (200)	1300 (800)	2500 (1600)	2500 (1600)	5000 (3200)
hours	20	80	160	160	320				
1	Air filter element	<ul style="list-style-type: none"> <li>Clean and replace if necessary.</li> </ul>		Every 20–40 hours (more often in wet or dusty areas)					
2	* Front brake	<ul style="list-style-type: none"> <li>Check operation and correct if necessary.</li> <li>Check fluid level and ATV for fluid leakage, and correct if necessary.</li> </ul>		√	√	√	√	√	
		<ul style="list-style-type: none"> <li>Replace brake pads.</li> </ul>		Whenever worn to the limit					
3	* Rear brake	<ul style="list-style-type: none"> <li>Check operation and correct if necessary.</li> <li>Check brake pedal free play and adjust if necessary.</li> <li>Check fluid level and ATV for fluid leakage, and correct if necessary.</li> </ul>		√	√	√	√	√	
		<ul style="list-style-type: none"> <li>Replace brake pads.</li> </ul>		Whenever worn to the limit					
4	* Brake hoses	<ul style="list-style-type: none"> <li>Check for cracks or other damage, and replace if necessary.</li> </ul>			√	√	√	√	
		<ul style="list-style-type: none"> <li>Replace.</li> </ul>		Every 4 years					
5	* Rear brake hose protectors	<ul style="list-style-type: none"> <li>Check for wear, cracks or other damage, and replace if necessary.</li> </ul>		√	√	√	√	√	
6	* Wheels	<ul style="list-style-type: none"> <li>Check runout and for damage, and replace if necessary.</li> </ul>		√		√	√	√	
7	* Tires	<ul style="list-style-type: none"> <li>Check tread depth and for damage, and replace if necessary.</li> <li>Check air pressure and balance, and correct if necessary.</li> </ul>		√		√	√	√	

NO.	ITEM	CHECK OR MAINTENANCE JOB	Whichever comes first ⇒	INITIAL			EVERY		
				month	1	3	6	6	12
				km (mi)	320 (200)	1300 (800)	2500 (1600)	2500 (1600)	5000 (3200)
hours	20	80	160	160	320				
8	* Wheel hub bearings	• Check for looseness or damage, and replace if necessary.		√		√	√	√	
9	* V-belt	• Check for wear, cracks or other damage, and replace if necessary.		√		√	√	√	
10	* Chassis fasteners	• Make sure that all nuts, bolts, and screws are properly tightened.		√	√	√	√	√	
11	* Shock absorber assemblies	• Check operation and correct if necessary. • Check for oil leakage and replace if necessary.				√	√	√	
12	* Stabilizer bushes	• Check for cracks or other damage, and replace if necessary.				√	√	√	
13	* Rear knuckle pivots	• Lubricate with lithium-soap-based grease.				√	√	√	
14	* Steering shaft	• Lubricate with lithium-soap-based grease.				√	√	√	
15	* Steering system	• Check operation and repair or replace if damaged. • Check toe-in and adjust if necessary.		√	√	√	√	√	
16	* Engine mount	• Check for cracks or other damage, and replace if necessary.				√	√	√	
17	* Axle boots	• Check for cracks or other damage, and replace if necessary.		√	√	√	√	√	
18	Engine oil	• Change. • Check ATV for oil leakage, and correct if necessary.		√		√	√	√	
19	Engine oil filter cartridge	• Replace.		√		√		√	

NO.	ITEM	CHECK OR MAINTENANCE JOB	Whichever comes first ⇒	INITIAL			EVERY		
				month	1	3	6	6	12
				km (mi)	320 (200)	1300 (800)	2500 (1600)	2500 (1600)	5000 (3200)
hours	20	80	160	160	320				
20	Differential gear oil	<ul style="list-style-type: none"> <li>Change.</li> <li>Check ATV for oil leakage, and correct if necessary.</li> </ul>		√				√	
21	Final gear oil	<ul style="list-style-type: none"> <li>Change.</li> <li>Check ATV for oil leakage, and correct if necessary.</li> </ul>		√				√	
22	Cooling system	<ul style="list-style-type: none"> <li>Check coolant level and ATV for coolant leakage, and correct if necessary.</li> </ul>		√	√	√	√	√	
		<ul style="list-style-type: none"> <li>Replace coolant.</li> </ul>	Every 2 years						
23	* Moving parts and cables	<ul style="list-style-type: none"> <li>Lubricate.</li> </ul>			√	√	√	√	
24	* Drive select lever safety system cable	<ul style="list-style-type: none"> <li>Check operation and adjust or replace if necessary.</li> </ul>				√	√	√	
25	* Throttle lever housing and cable	<ul style="list-style-type: none"> <li>Check operation and correct if necessary.</li> <li>Check throttle cable free play and adjust if necessary.</li> <li>Lubricate throttle lever housing and cable.</li> </ul>		√	√	√	√	√	
26	* Front and rear brake switches	<ul style="list-style-type: none"> <li>Check operation and correct if necessary.</li> </ul>		√	√	√	√	√	
27	* Lights and switches	<ul style="list-style-type: none"> <li>Check operation and correct if necessary.</li> <li>Adjust headlight beams.</li> </ul>		√	√	√	√	√	

**TIP**

---

- The air filter needs more frequent service if you are riding in unusually wet or dusty areas.
  - Hydraulic brake service
    - Regularly check and, if necessary, correct the brake fluid level.
    - Every two years replace the internal components of the brake master cylinders and calipers, and change the brake fluid.
    - Replace the brake hoses every four years and if cracked or damaged.
-



Indicates a potential hazard that could result in serious injury or death.

## Removing and installing panels

The panels shown need to be removed to perform some of the maintenance jobs described in this chapter. Refer to this section each time a panel needs to be removed and installed.

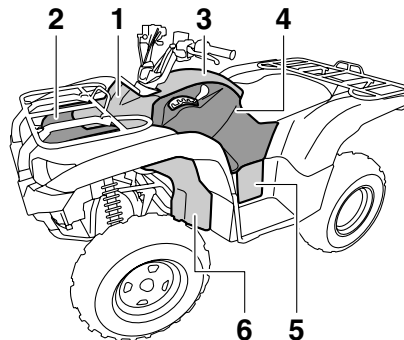

1. Panel A
2. Panel B
3. Panel C
4. Panel D
5. Panel F
6. Panel G

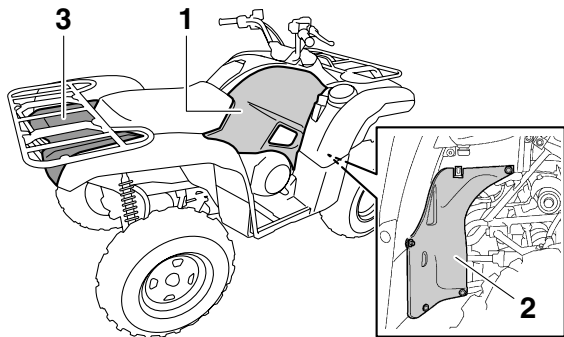

- 1. Panel E
- 2. Panel H
- 3. Panel I

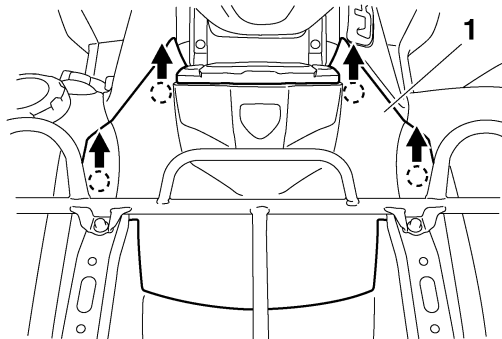

- 1. Panel A

To install the panel  
Place the panel in the original position.

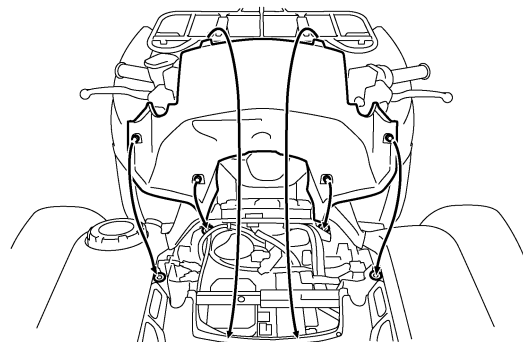

## Panel A

To remove the panel  
Pull upward on the areas shown.

## Panel B

### To remove the panel

1. Remove panel A.
2. Remove the front carrier by removing the bolts.

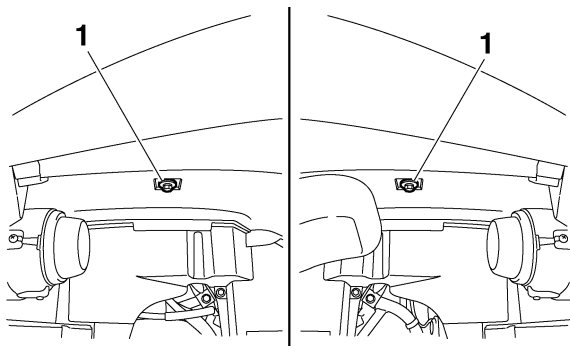

1. Carrier bolt (under the fenders)

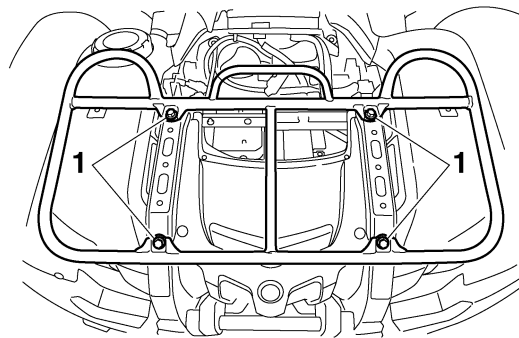

1. Carrier bolt (top)

3. Remove the front carrier stays by removing the bolts.

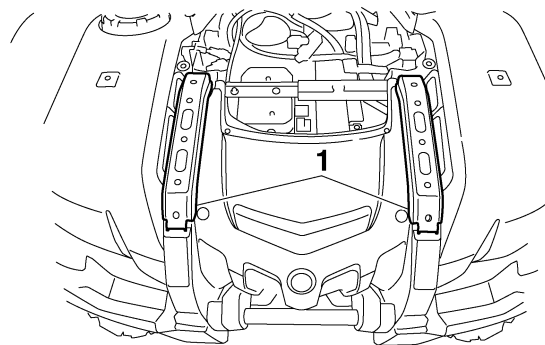

1. Front carrier stay

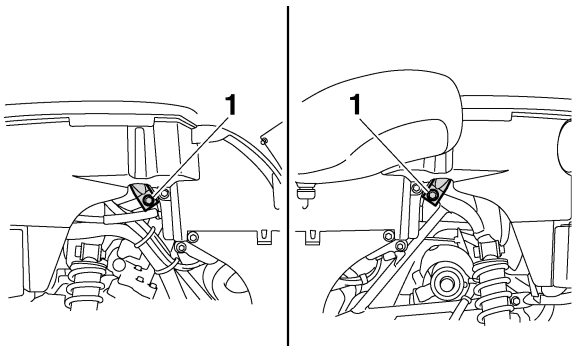

1. Front carrier stay bolt

4. Remove the quick fasteners, and then pull the panel upward to remove it.

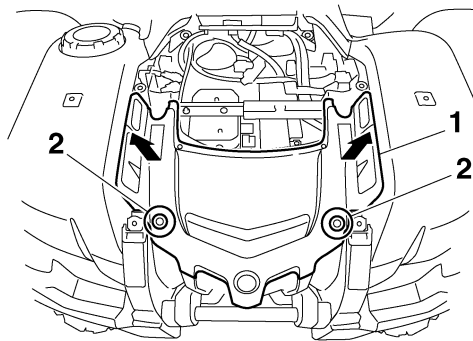

1. Panel B

2. Quick fastener

#### To install the panel

1. Place the panel in the original position, and then install the quick fasteners.



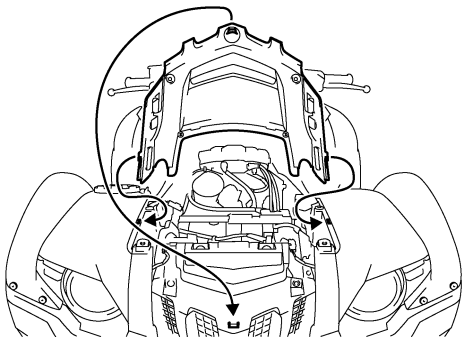

2. Install the front carrier stays by installing the bolts and tightening them to the specified torque.

Tightening torque:

Front carrier stay bolt:

34 Nm (3.4 m·kgf, 24 ft·lbf)

3. Install the front carrier by installing the bolts and tightening them to the specified torques.

Tightening torques:

Carrier bolt (top):

26 Nm (2.6 m·kgf, 19 ft·lbf)

Carrier bolt (under the fenders):

7 Nm (0.7 m·kgf, 5.1 ft·lbf)

4. Install panel A.

### Panel C

#### To remove the panel

1. Remove the seat. (See page 4-19.)
2. Remove panel A.
3. Remove the quick fastener screws, and then pull the panel upward to remove it.

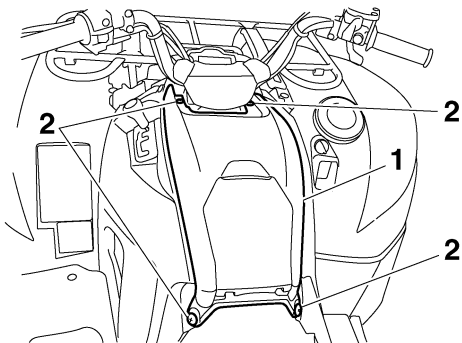

1. Panel C
2. Quick fastener screw

#### To install the panel

1. Place the panel in the original position, and then install the quick fastener screws.

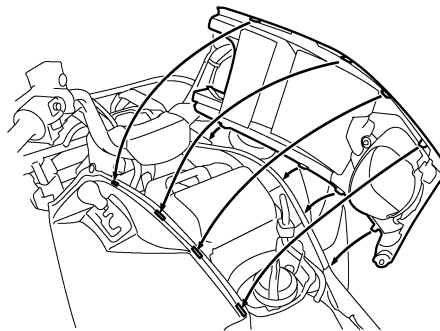

2. Install panel A.
3. Install the seat.

#### **Panels D and E**

##### To remove one of the panels

1. Remove panel C.
2. Remove the quick fastener screw and bolt, and then pull the panel upward to remove it.

#### **TIP**

To ease removal of panel D, shift the drive select lever into the reverse position.

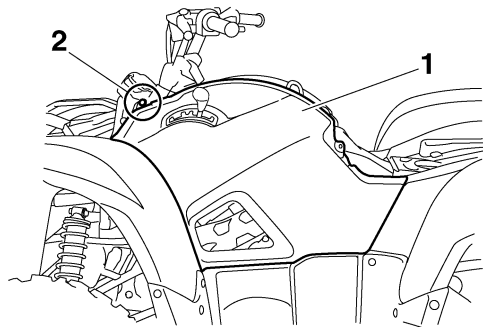

- 1. Panel D
- 2. Quick fastener screw

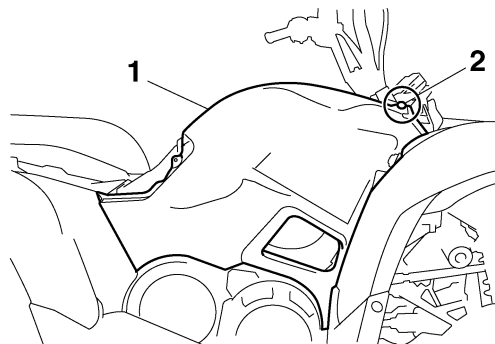

- 1. Panel E
- 2. Quick fastener screw

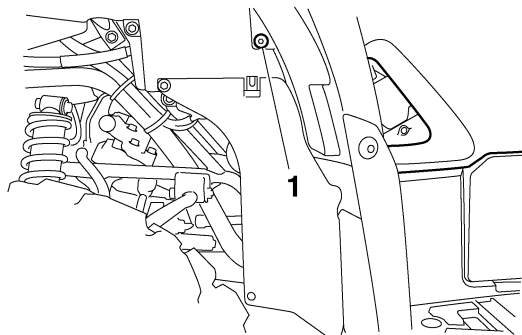

- 1. Bolt

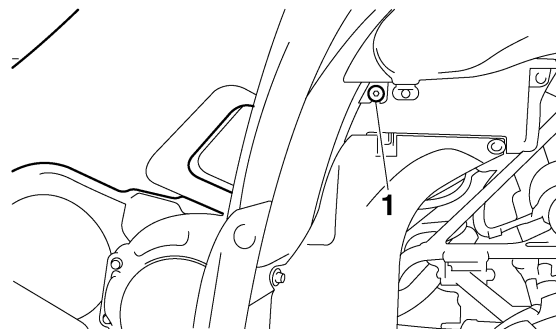

- 1. Bolt

To install one of the panels

1. Place the panel in the original position, and then install the bolt and quick fastener screw.

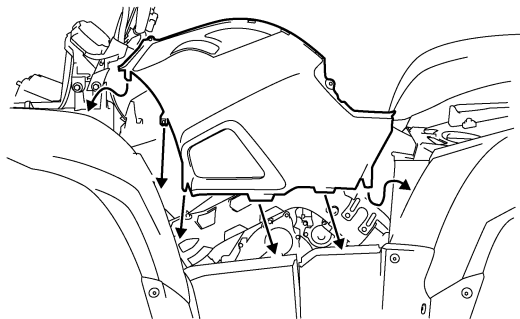

8

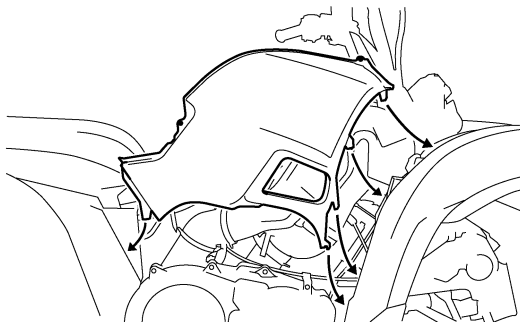

2. Install panel C.

**Panel F**

To remove the panel

Pull outward on the areas shown.

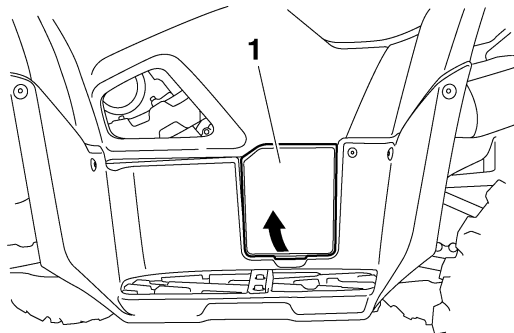

1. Panel F

To install the panel

Place the panel in the original position.

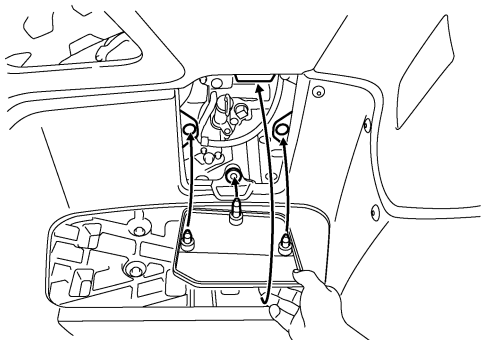

## Panels G and H

### To remove one of the panels

Remove the nut and bolts, and then pull the panel downward while pushing the projection.

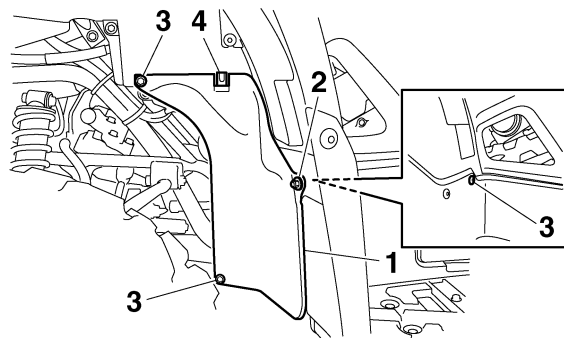

1. Panel G
2. Nut
3. Bolt
4. Projection

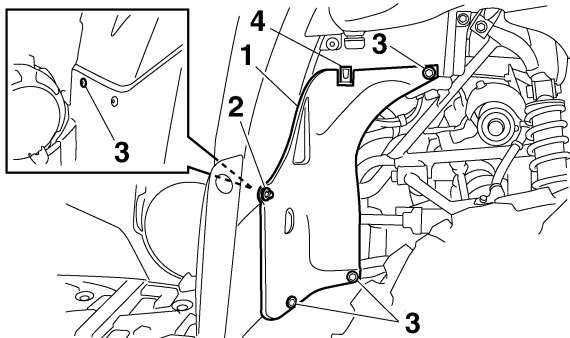

1. Panel H
2. Nut
3. Bolt
4. Projection

**8**

**To install one of the panels**

Place the panel in the original position, and then install the bolts and nut.

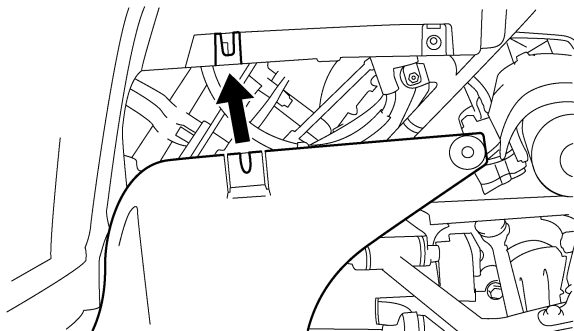
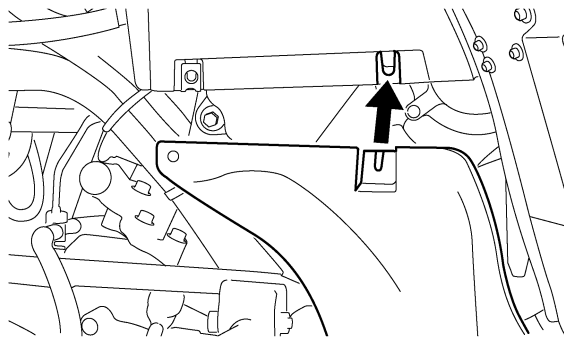

**Panel I**

**To remove the panel**

1. Remove the seat. (See page 4-19.)

2. Remove the rear carrier by removing the bolts.

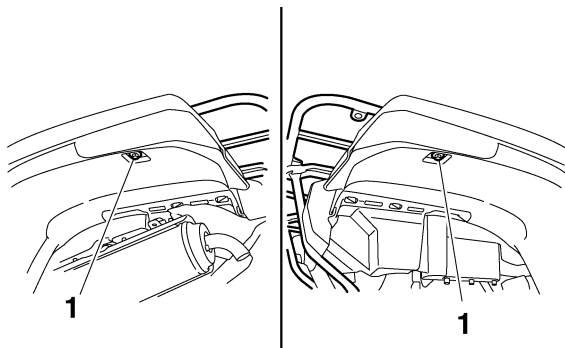

1. Carrier bolt (under the fenders)

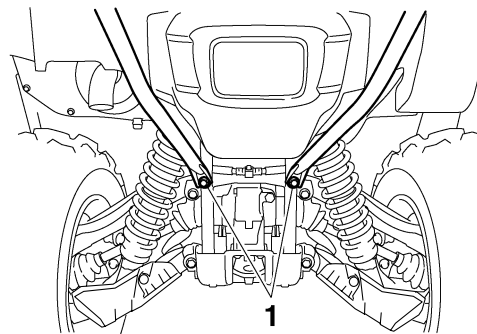

1. Carrier bolt (lower)

3. Remove the quick fasteners, and then push inward on the areas shown.

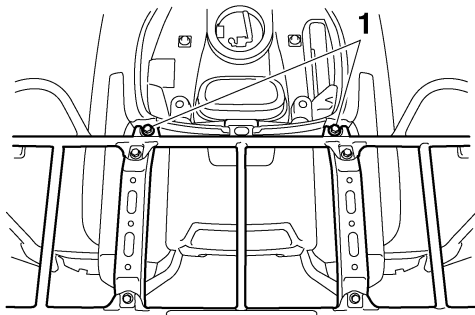

1. Carrier bolt (upper)

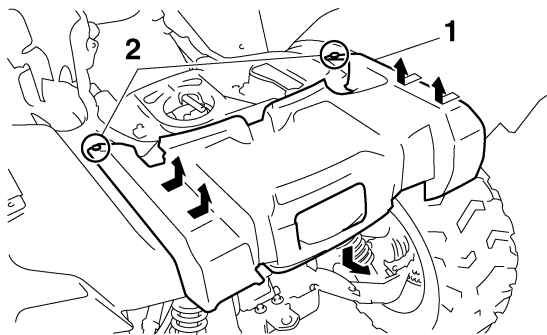

1. Panel I
2. Quick fastener

#### To install the panel

1. Place the panel in the original position, and then install the quick fasteners.

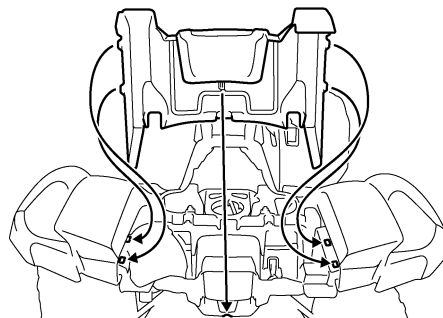

2. Install the rear carrier by installing the bolts and tightening them to the specified torques.

#### Tightening torques:

Carrier bolt (upper):

53 Nm (5.3 m·kgf, 38 ft·lbf)

Carrier bolt (lower):

53 Nm (5.3 m·kgf, 38 ft·lbf)

Carrier bolt (under the fenders):

7 Nm (0.7 m·kgf, 5.1 ft·lbf)

3. Install the seat.



## Removing the radiator grills

The radiator grills can be removed to access the radiator for cleaning.

### To remove a radiator grill

Remove the quick fastener, pull the radiator grill outward at the top, and then pull it upward.

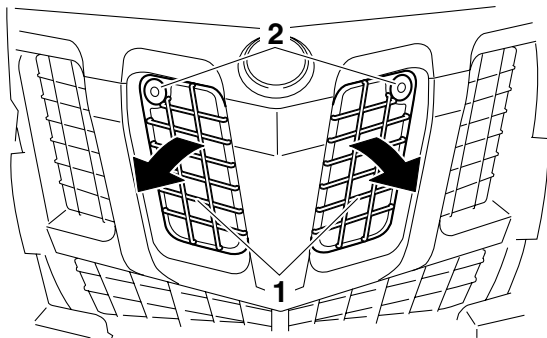

1. Radiator grill
2. Quick fastener

### To install a radiator grill

Place the radiator grill in its original position, and then install the quick fastener.

## Checking the spark plug

The spark plug is an important engine component, which is easy to check. Since heat and deposits will cause any spark plug to slowly erode, the spark plug should be removed and checked in accordance with the periodic maintenance and lubrication chart. In addition, the condition of the spark plug can reveal the condition of the engine.

### To remove the spark plug

1. Remove the spark plug cap.

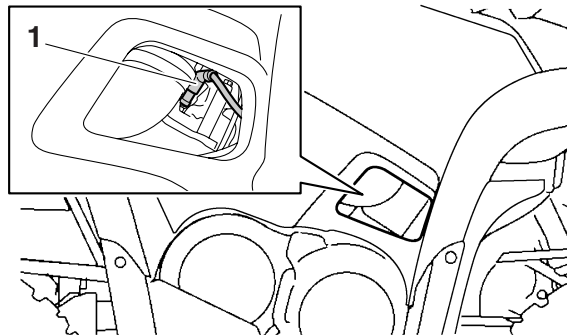

1. Spark plug cap

2. Remove the spark plug as shown, with the spark plug wrench included in the owner's tool kit.

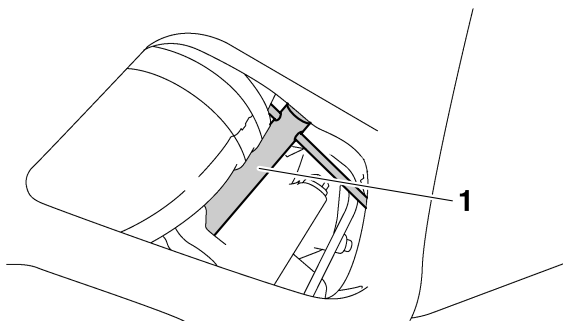

1. Spark plug wrench

8

### To check the spark plug

1. Check that the porcelain insulator around the center electrode of the spark plug is a medium-to-light tan (the ideal color when the ATV is ridden normally).

### TIP

If the spark plug shows a distinctly different color, the engine could be operating improperly. Do not attempt to diagnose such problems yourself. Instead, have a Yamaha dealer check the ATV.

2. Check the spark plug for electrode erosion and excessive carbon or other deposits, and replace it if necessary.

Specified spark plug:  
NGK/LMAR6A-9

### To install the spark plug

1. Measure the spark plug gap with a wire thickness gauge and, if necessary, adjust the gap to specification.

Spark plug gap:  
0.8–0.9 mm (0.031–0.035 in)

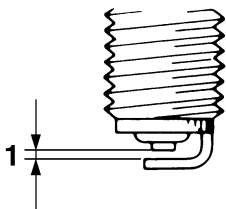

1. Spark plug gap
2. Clean the surface of the spark plug gasket and its mating surface, and then wipe off any grime from the spark plug threads.
3. Install the spark plug with the spark plug wrench, and then tighten it to the specified torque.

Tightening torque:

Spark plug:

12.5 Nm (1.25 m·kgf, 9.0 ft·lbf)

### TIP

If a torque wrench is not available when installing a spark plug, a good estimate of the correct torque is 1/4–1/2 turn past finger tight. However, the spark plug should be tightened to the specified torque as soon as possible.

4. Install the spark plug cap.

EBU27462

## Engine oil and oil filter cartridge

The engine oil level should be checked before each ride. In addition, the oil must be changed and the oil filter cartridge replaced at the intervals specified in the periodic maintenance and lubrication chart.

### To check the engine oil level

1. Place the ATV on a level surface.
2. Check the engine oil level on a cold engine.

### TIP

If the engine was started before checking the oil level, be sure to warm up the engine sufficiently, and then wait at least 10 minutes until the oil settles for an accurate reading.

3. Remove panel F. (See page 8-8.)

4. Remove the dipstick, and then wipe it off with a clean rag.

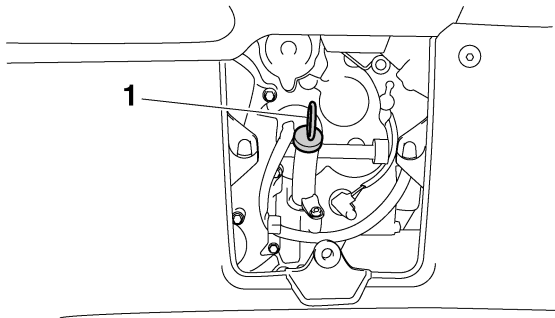

1. Dipstick

5. Insert the dipstick completely into the oil filler hole, and then remove it again to check the oil level.

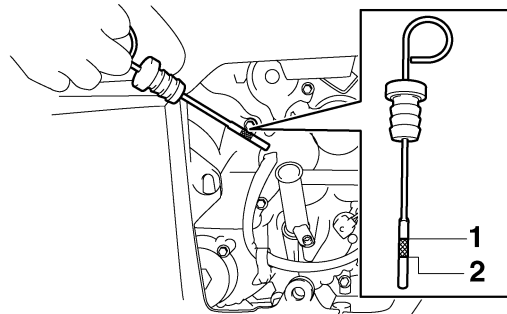

1. Maximum level mark
2. Minimum level mark

### **TIP**

The engine oil should be between the minimum and maximum level marks.

6. If the engine oil is at or below the minimum level mark, add sufficient oil of the recommended type to raise it to the correct level.
7. Insert the dipstick completely into the oil filler hole.
8. Install the panel.

**NOTICE**

**Be sure the engine oil is at the correct level, otherwise engine damage may result.**

**To change the engine oil (with or without oil filter cartridge replacement)**

1. Place the ATV on a level surface.
2. Remove panel F. (See page 8-8.)
3. Place an oil pan under the engine to collect the used oil.
4. Remove the dipstick, and then remove the engine oil drain bolt to drain the oil from the crankcase.

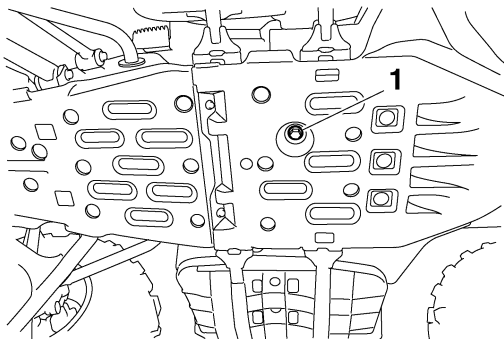

1. Engine oil drain bolt

**TIP**

Skip steps 5–9 if the oil filter cartridge is not being replaced.

5. Remove panel G. (See page 8-8.)
6. Remove the oil filter cartridge with an oil filter wrench.

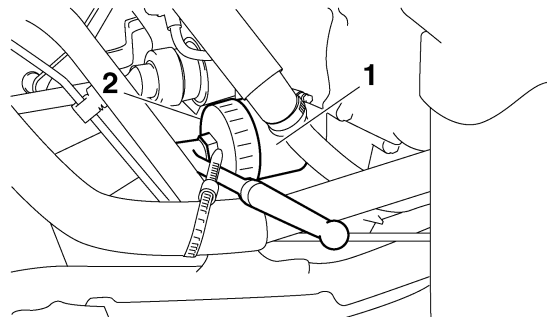

1. Oil filter cartridge
2. Oil filter wrench

**TIP**

An oil filter wrench is available at a nearby Yamaha dealer.

7. Apply a thin coat of engine oil to the O-ring of the new oil filter cartridge.

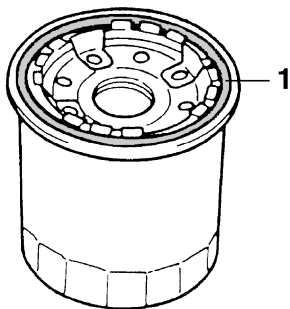

1. O-ring

**TIP** \_\_\_\_\_  
Make sure that the O-ring is properly seated.

8

8. Install the new oil filter cartridge with an oil filter wrench, and then tighten it to the specified torque with a torque wrench.

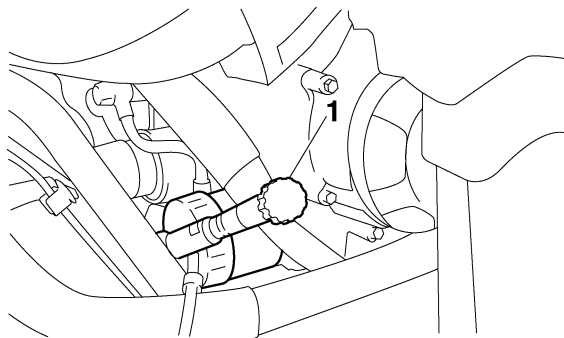

1. Torque wrench

Tightening torque:  
Oil filter cartridge:  
17 Nm (1.7 m·kgf, 12 ft·lbf)

9. Install panel G.  
10. Install the engine oil drain bolt, and then tighten it to the specified torque.

Tightening torque:  
Engine oil drain bolt:  
30 Nm (3.0 m·kgf, 22 ft·lbf)

11. Refill with the specified amount of the recommended engine oil, and then insert the dipstick completely into the oil filler hole.

Recommended oil:

See page 10-1.

Oil quantity:

Without oil filter cartridge replacement:

2.00 L (2.11 US qt, 1.76 Imp.qt)

With oil filter cartridge replacement:

2.10 L (2.22 US qt, 1.85 Imp.qt)

### TIP

Be sure to wipe off spilled oil on any parts after the engine and exhaust system have cooled down.

ECB00300

### NOTICE

- **In order to prevent clutch slippage (since the engine oil also lubricates the clutch), do not mix any chemical additives. Do not use oils with a diesel specification of “CD” or oils of a higher quality than specified. In addition, do not use oils labeled “ENERGY CONSERVING II” or higher.**

- **Make sure that no foreign material enters the crankcase.**

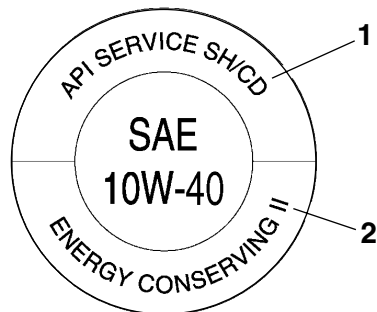

1. “CD” specification
2. “ENERGY CONSERVING II”
12. Start the engine, and then let it idle for several minutes while checking it for oil leakage. If oil is leaking, immediately turn the engine off and check for the cause.
13. Turn the engine off, wait at least ten minutes, and then check the oil level and correct it if necessary.
14. Install panel F.

## Final gear oil

The final gear case must be checked for oil leakage before each ride. If any leakage is found, have a Yamaha dealer check and repair the ATV. In addition, the final gear oil level must be checked and the oil changed as follows at the intervals specified in the periodic maintenance and lubrication chart.

### To check the final gear oil level

1. Place the ATV on a level surface.

#### TIP

The final gear oil level must be checked on a cold engine.

2. Remove the final gear oil level check bolt, and then check the oil level in the final gear case.

#### TIP

The oil level should be at the brim of the check hole.

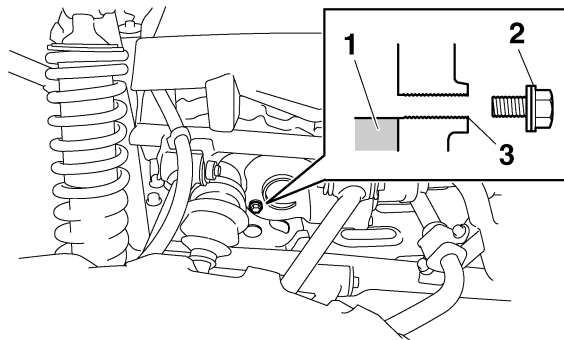

1. Final gear oil
  2. Final gear oil level check bolt
  3. Correct oil level
3. If the oil is below the brim of the check hole, remove the final gear oil filler bolt, and then add sufficient oil of the recommended type to raise it to the correct level.



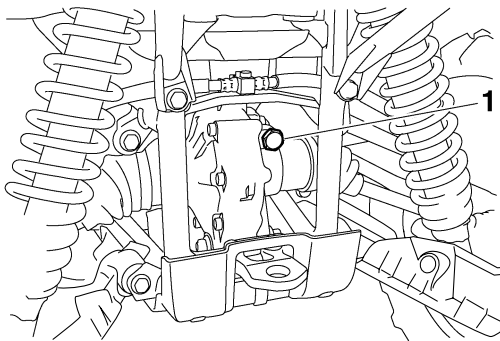

1. Final gear oil filler bolt

4. Install the oil level check bolt and oil filler bolt, and then tighten them to the specified torques.

**Tightening torques:**

Final gear oil level check bolt:  
10 Nm (1.0 m·kgf, 7.2 ft·lbf)

Final gear oil filler bolt:  
23 Nm (2.3 m·kgf, 17 ft·lbf)

**To change the final gear oil**

1. Place the ATV on a level surface.
2. Place an oil pan under the final gear case to collect the used oil.

3. Remove the final gear oil filler bolt, final gear oil level check bolt, and the final gear oil drain bolt to drain the oil from the final gear case.

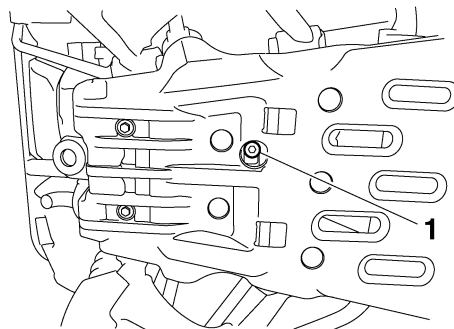

1. Final gear oil drain bolt

4. Install the drain bolt, and then tighten it to the specified torque.

**Tightening torque:**

Final gear oil drain bolt:  
23 Nm (2.3 m·kgf, 17 ft·lbf)

5. Refill with the recommended final gear oil to the brim of the check hole as shown.

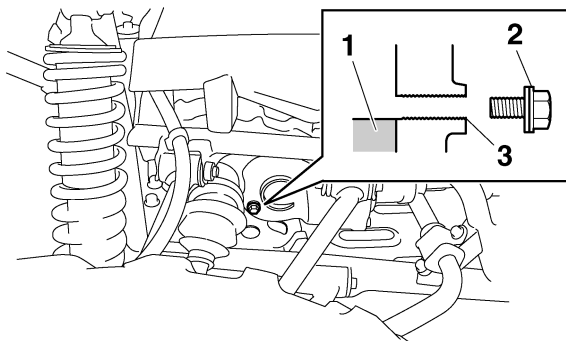

1. Final gear oil
2. Final gear oil level check bolt
3. Correct oil level

8

Recommended final gear oil:  
See page 10-1.

ECB00420

### **NOTICE**

**Be sure no foreign material enters the final gear case.**

6. Install the oil level check bolt and oil filler bolt, and then tighten them to the specified torques.

Tightening torques:

Final gear oil level check bolt:  
10 Nm (1.0 m·kgf, 7.2 ft·lbf)

Final gear oil filler bolt:  
23 Nm (2.3 m·kgf, 17 ft·lbf)

7. Check the final gear case for oil leakage. If oil is leaking, check for the cause.

EBU23422

## **Differential gear oil**

The differential gear case must be checked for oil leakage before each ride. If any leakage is found, have a Yamaha dealer check and repair the ATV. In addition, the differential gear oil level must be checked and the oil changed as follows at the intervals specified in the periodic maintenance and lubrication chart.

### **To check the differential gear oil level**

1. Place the ATV on a level surface.

### **TIP**

The differential gear oil level must be checked on a cold engine.

2. Remove the differential gear oil filler bolt, and then check the oil level in the differential gear case.

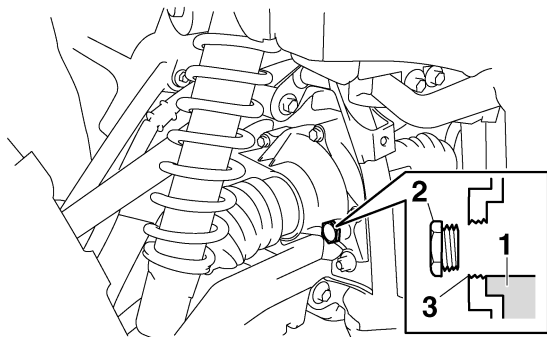

1. Differential gear oil
2. Differential gear oil filler bolt
3. Correct oil level

### TIP

The oil level should be at the brim of the filler hole.

3. If the oil is below the brim of the filler hole, add sufficient oil of the recommended type to raise it to the correct level.
4. Install the oil filler bolt, and then tighten it to the specified torque.

Tightening torque:

Differential gear oil filler bolt:  
23 Nm (2.3 m·kgf, 17 ft·lbf)

### To change the differential gear oil

1. Place the ATV on a level surface.
2. Place an oil pan under the differential gear case to collect the used oil.
3. Remove the differential gear oil filler bolt and the differential gear oil drain bolt to drain the oil from the differential gear case.

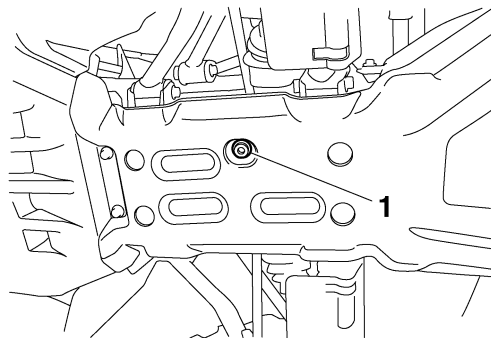

1. Differential gear oil drain bolt
4. Install the drain bolt, and then tighten it to the specified torque.

**Tightening torque:**

Differential gear oil drain bolt:  
10 Nm (1.0 m·kgf, 7.2 ft·lbf)

5. Refill with the recommended differential gear oil to the brim of the filler hole as shown.

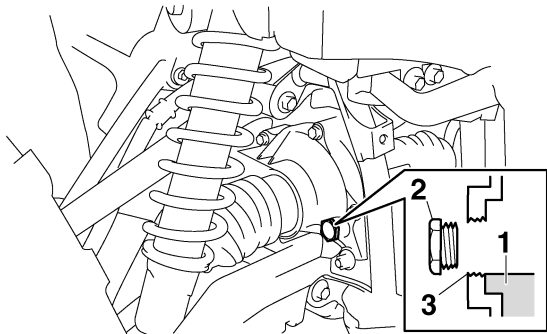

1. Differential gear oil
2. Differential gear oil filler bolt
3. Correct oil level

**Recommended differential gear oil:**  
See page 10-1.

ECB00410

**NOTICE**

**Be sure no foreign material enters the differential gear case.**

6. Install the oil filler bolt, and then tighten it to the specified torque.

**Tightening torque:**

Differential gear oil filler bolt:  
23 Nm (2.3 m·kgf, 17 ft·lbf)

7. Check the differential gear case for oil leakage. If oil is leaking, check for the cause.

EBU23470

**Coolant**

The coolant level should be checked before each ride. In addition, the coolant must be changed at the intervals specified in the periodic maintenance and lubrication chart.

EBU27123

**To check the coolant level**

1. Place the ATV on a level surface.

**TIP** \_\_\_\_\_  
The coolant level must be checked on a cold engine since the level varies with engine temperature.

2. Check the coolant level in the coolant reservoir.

**TIP** \_\_\_\_\_  
The coolant should be between the minimum and maximum level marks.

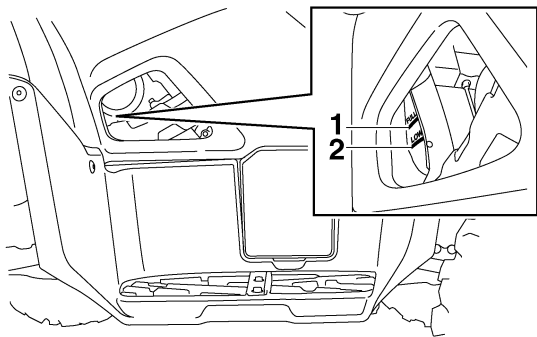

1. Maximum level mark
2. Minimum level mark

3. If the coolant is at or below the minimum level mark, remove panel D. (See page 8-8.)

4. Remove the coolant reservoir cap, add coolant or distilled water to the maximum level mark, install the reservoir cap, and then install the panel.

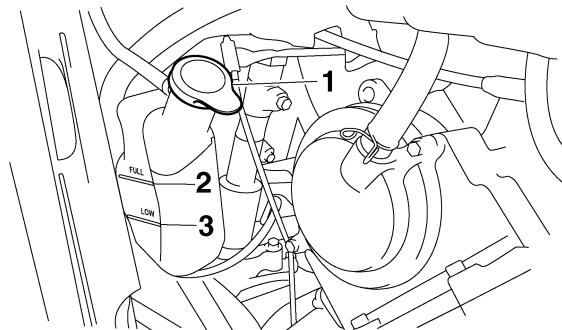

1. Coolant reservoir cap
2. Maximum level mark
3. Minimum level mark

Coolant reservoir capacity (up to the maximum level mark):  
0.24 L (0.25 US qt, 0.21 Imp.qt)

**NOTICE**

- If coolant is not available, use distilled water or soft tap water instead. Do not use hard water or salt water since it is harmful to the engine.
- If water has been used instead of coolant, replace it with coolant as soon as possible, otherwise the cooling system will not be protected against frost and corrosion.
- If water has been added to the coolant, have a Yamaha dealer check the antifreeze content of the coolant as soon as possible, otherwise the effectiveness of the coolant will be reduced.

**8****TIP**

- The radiator fan is automatically switched on or off according to the coolant temperature in the radiator.
- If the engine overheats, see page 8-67 for further instructions.

**To change the coolant****WARNING****POTENTIAL HAZARD**

Removing the radiator cap when the engine and radiator are still hot.

**WHAT CAN HAPPEN**

You could be burned by hot fluid and steam blown out under pressure.

**HOW TO AVOID THE HAZARD**

Wait for the engine to cool before removing the radiator cap. Always place a thick rag over the cap. Allow any remaining pressure to escape before completely removing the cap.

1. Place the ATV on a level surface.
2. Remove panels D and F. (See page 8-8.)
3. Place a container under the engine, and then remove the coolant drain bolt. (Use a trough or a similar object as shown to prevent coolant from spilling on the engine guard.)



1. Coolant drain bolt

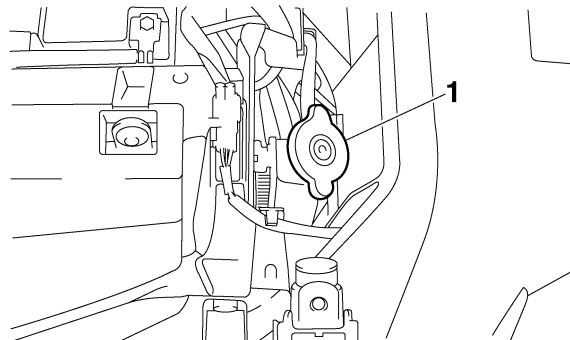

1. Radiator cap

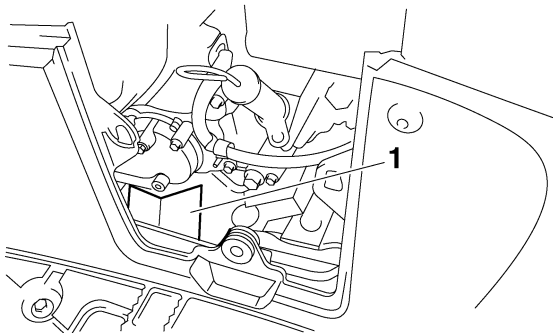

1. Trough

4. Remove panel B. (See page 8-8.)
5. Remove the radiator cap.

6. Remove the coolant reservoir cap.
7. Disconnect the hose on the coolant reservoir side, and then drain the coolant from the coolant reservoir.

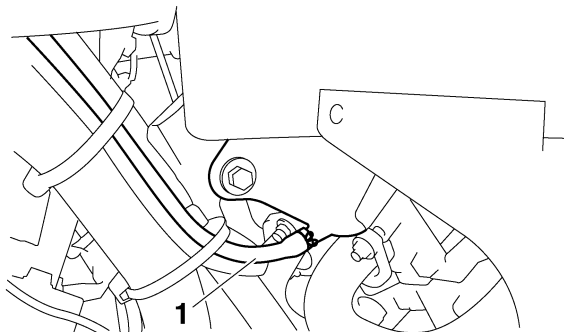

1. Coolant reservoir hose

8. After draining the coolant, thoroughly flush the cooling system with clean tap water.
9. Replace the coolant drain bolt washer if it is damaged, install the coolant drain bolt, and then tighten it to the specified torque.

Tightening torque:

Coolant drain bolt:

10 Nm (1.0 m·kgf, 7.2 ft·lbf)

10. Connect the coolant reservoir hose.
11. Pour the recommended coolant into the radiator until it is full.

12. Pour the recommended coolant into the reservoir to the maximum level mark, and then install the reservoir cap.

Antifreeze/water mixture ratio:

1:1

Recommended antifreeze:

High-quality ethylene glycol antifreeze containing corrosion inhibitors for aluminum engines

Coolant quantity:

Radiator capacity (including all routes):

1.99 L (2.10 US qt, 1.75 Imp.qt)

Coolant reservoir capacity (up to the maximum level mark):

0.24 L (0.25 US qt, 0.21 Imp.qt)

ECB00401

### **NOTICE**

- **If coolant is not available, use distilled water or soft tap water instead. Do not use hard water or salt water since it is harmful to the engine.**
- **If water has been used instead of coolant, replace it with coolant as soon as possible, otherwise the cooling system will not be protected against frost and corrosion.**



- If water has been added to the coolant, have a Yamaha dealer check the antifreeze content of the coolant as soon as possible, otherwise the effectiveness of the coolant will be reduced.

13. Loosen the water pump air bleed bolt, without removing it, to allow all of the air to escape from the air bleed bolt hole.

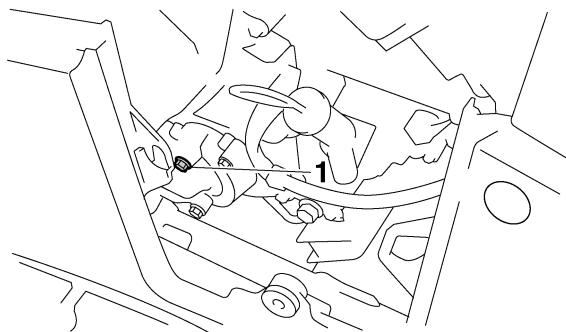

1. Water pump air bleed bolt

14. When coolant begins to flow out of the bolt hole, tighten the water pump air bleed bolt to the specified torque.

Tightening torque:  
Water pump air bleed bolt:  
10 Nm (1.0 m·kgf, 7.2 ft·lbf)

15. Remove panel E. (See page 8-8.)
16. Loosen the clamp screw, and then remove the V-belt cooling duct.

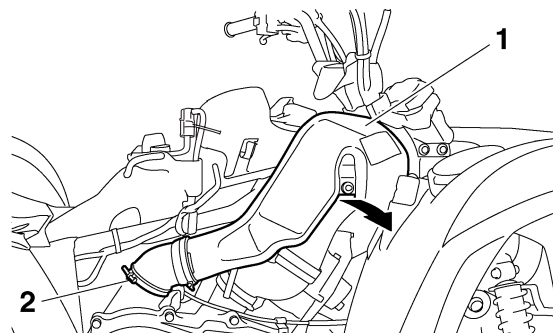

1. V-belt cooling duct
2. Clamp screw

17. Loosen the cylinder head air bleed bolt, without removing it, to allow all of the air to escape from the air bleed bolt hole.

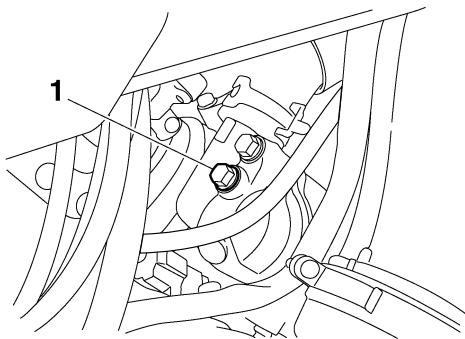

1. Cylinder head air bleed bolt

18. When coolant begins to flow out of the bolt hole, tighten the cylinder head air bleed bolt to the specified torque.

Tightening torque:

Cylinder head air bleed bolt:  
10 Nm (1.0 m·kgf, 7.2 ft·lbf)

19. Start the engine and let it idle for ten minutes.  
20. Rev the engine five times.  
21. Pour the recommended coolant into the radiator until it is full.

22. Stop the engine and allow it to cool. If the coolant level has dropped after the engine has cooled, add sufficient coolant until it reaches the top of the radiator, and then install the radiator cap.  
23. Start the engine, and then check for coolant leakage.

#### TIP

If any leakage is found, have a Yamaha dealer check the cooling system.

24. Install the V-belt cooling duct, and then tighten the clamp screw.  
25. Install the panels.

EBU27455

### Cleaning the air filter element

The air filter element should be cleaned at the intervals specified in the periodic maintenance and lubrication chart. Clean or, if necessary, replace the air filter element more frequently if you are riding in unusually wet or dusty areas.

#### TIP

There are two check hoses at the bottom of the air filter case, which are located behind panels D and E. (See page 8-8 for an explanation on removing

the panels.) Check the hoses periodically and, if dust or water collects in them, empty them and clean the air filter element and air filter case.

---

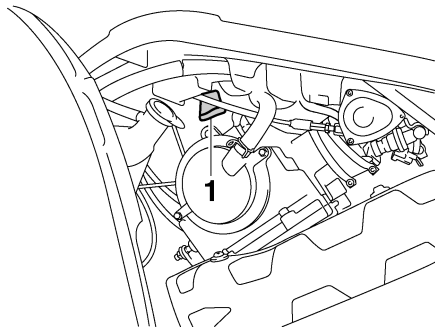

1. Air filter case check hose

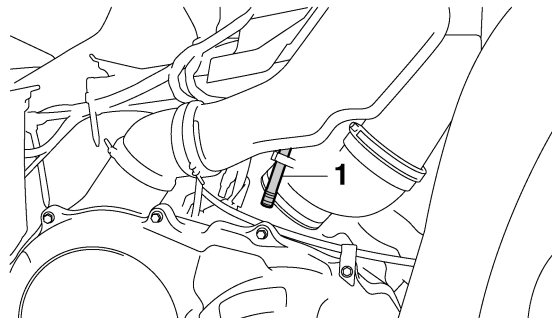

1. Air filter case check hose

1. Place the ATV on a level surface.
2. Remove panel C. (See page 8-9.)
3. Remove the air filter case cover by unhooking the holders.

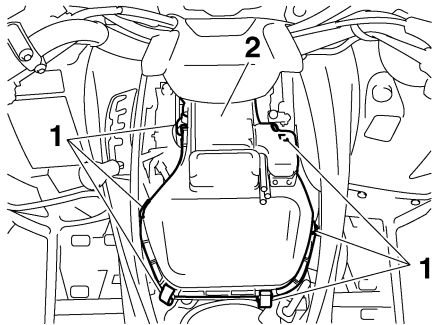

1. Air filter case cover holder
2. Air filter case cover

4. Remove the sponge material and the mesh from the air filter case.

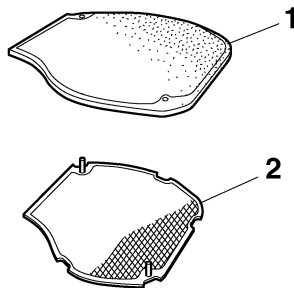

1. Sponge material
2. Air filter mesh

5. Clean the mesh with solvent, and then wipe the solvent off.
6. Wash the sponge material gently, but thoroughly, in solvent.

8

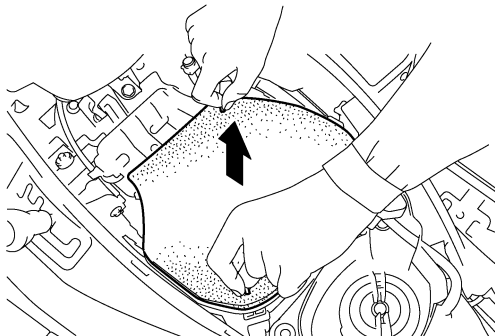

EWB01900

**⚠ WARNING**

**POTENTIAL HAZARD**

**Using low-flash-point solvents or gasoline to clean the sponge material.**

**WHAT CAN HAPPEN**

**Low-flash-point solvents or gasoline can catch fire or explode.**

## HOW TO AVOID THE HAZARD

Use parts cleaning solvent to clean the sponge material.

7. Squeeze the excess solvent out of the sponge material and let it dry.

ECB00440

### NOTICE

Do not twist the sponge material when squeezing it.

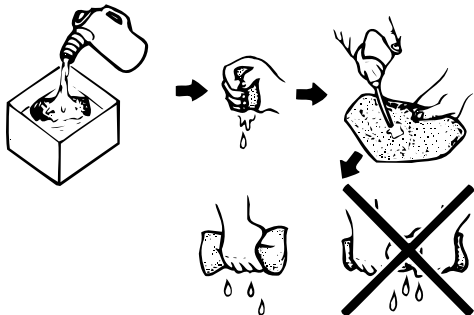

8. Check the sponge material and replace it if damaged.
9. Apply Yamaha foam air filter oil or other quality foam air filter oil to the sponge material.

### TIP

The sponge material should be wet but not dripping.

10. Install the mesh and the sponge material into the air filter case.
11. Insert the projections on the air filter case cover into the holders on the air filter case, and then install the air filter case cover by hooking the holders onto the cover.

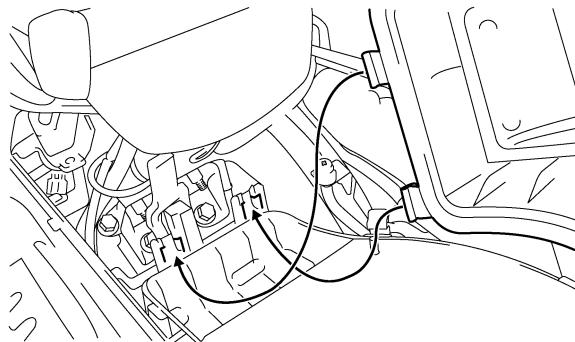

12. Place the hoses in their original position as shown.

**NOTICE**

- Make sure that the air filter element is properly seated in the air filter case.
- Never operate the engine with the air filter element removed. This will allow unfiltered air to enter the engine, causing rapid engine wear and possible engine damage. Additionally, operation without the air filter element will affect the fuel injection system with subsequent poor performance and possible engine overheating.

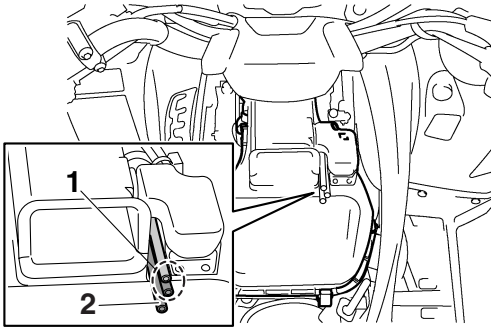

1. Hose (for all models)
2. Hose (for EPS model only)

13. Install the panel.

**8**

**TIP**

The air filter element should be cleaned every 20–40 hours. It should be cleaned and lubricated more often if the ATV is operated in extremely dusty areas. Each time the air filter element maintenance is performed, check the air inlet of the air filter case for obstructions. Check the air filter case rubber joint to the throttle body and the rubber joint manifold fittings for an air-tight seal. Tighten all fittings securely to avoid the possibility of unfiltered air entering the engine.

**Cleaning the spark arrester**

Select a well-ventilated area free of combustible materials and make sure the exhaust and muffler are cool.

1. Remove the bolts.

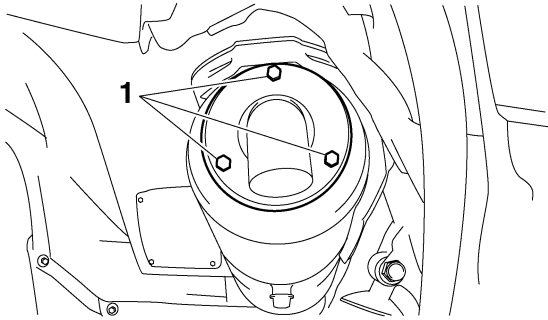

1. Bolt

2. Remove the tailpipe, by pulling it out of the muffler, and then remove the gasket.
3. Tap the tailpipe lightly, and then use a wire brush to remove any carbon deposits from the spark arrester portion of the tailpipe and inside of the tailpipe housing.

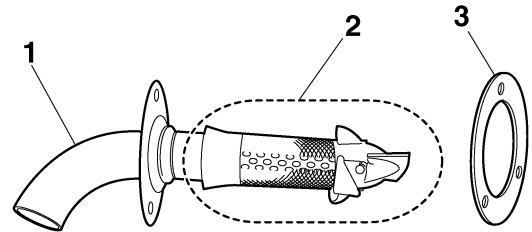

1. Tailpipe
2. Spark arrester
3. Gasket

4. Install the gasket, and then insert the tailpipe into the muffler and align the bolt holes.
5. Install the bolts and tighten them to the specified torque.

Tightening torque:

Tailpipe bolt:

10 Nm (1.0 m·kgf, 7.2 ft·lbf)

6. Remove the purging bolt.

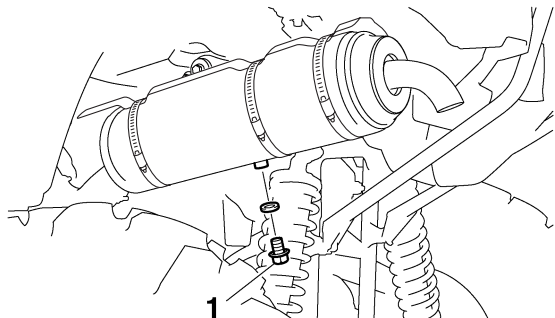

1. Purging bolt

7. Start the engine and rev it up approximately twenty times while momentarily creating exhaust system back pressure by blocking the end of the muffler with a shop towel.
8. Stop the engine and allow the exhaust pipe to cool.
9. Install the purging bolt and tighten it to the specified torque.

Tightening torque:

Purging bolt:

27 Nm (2.7 m·kgf, 19 ft·lbf)

EWB01930

**⚠ WARNING**

**POTENTIAL HAZARD**

**Improperly purging the exhaust system.**

**Hot exhaust system.**

**WHAT CAN HAPPEN**

**Could injure the eyes.**

**Could cause burns.**

**Could cause carbon monoxide poisoning, possibly leading to death.**

**Could start a fire.**

**HOW TO AVOID THE HAZARD**

**When purging the exhaust system:**

**Always let the exhaust system cool prior to touching exhaust components.**

**Always wear eye protection, and make sure no one is behind the ATV.**

**Never run the engine in an enclosed area.**

**Make sure there are no combustible materials in the area.**

EBU23930

**V-belt case drain plug**

After riding in water deep enough to allow it to enter the V-belt case, remove this plug to drain the water from the case.



## TIP

If water drains from the V-belt case after removing the plug, have a Yamaha dealer check the ATV as the water may affect other engine parts.

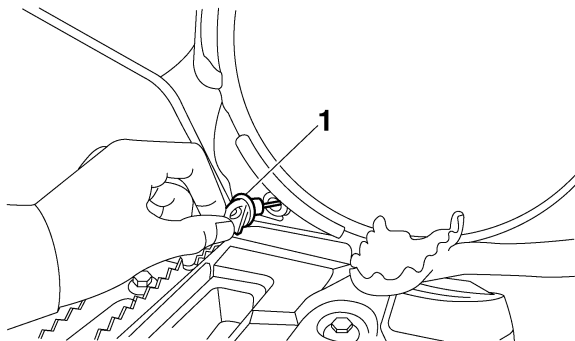

1. V-belt case drain plug

EBU24044

## Adjusting the throttle cable free play

The throttle cable free play should be checked and, if necessary, adjusted at the intervals specified in the periodic maintenance and lubrication chart.

The throttle cable free play should measure 3.0–5.0 mm (0.12–0.20 in) at the throttle lever. Periodically check the throttle cable free play and, if necessary, adjust it as follows.

## TIP

The engine idling speed must be checked, and adjusted if necessary, before adjusting the throttle cable free play.

1. Loosen the locknut.
2. To increase the throttle cable free play, turn the throttle cable free play adjusting bolt in direction (a). To decrease the throttle cable free play, turn the adjusting bolt in direction (b).

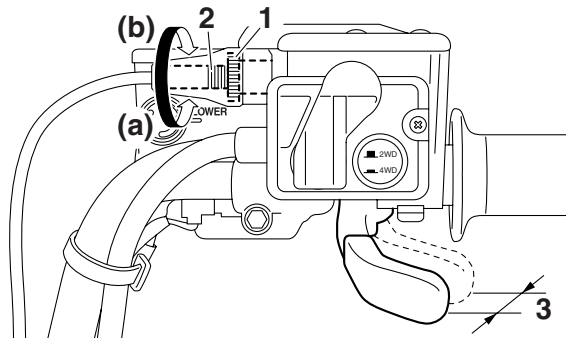

1. Locknut
  2. Throttle cable free play adjusting bolt
  3. Throttle cable free play
3. Tighten the locknut.

8

EBU24060

## Valve clearance

The valve clearance changes with use, resulting in improper air-fuel mixture and/or engine noise. To prevent this from occurring, the valve clearance must be adjusted by a Yamaha dealer at the intervals specified in the periodic maintenance and lubrication chart.

EBU24070

## Adjusting the drive select lever safety system cable

The drive select lever safety system cable stretches with use, which can result in improper function. Therefore, the safety system cable should be checked and adjusted at the intervals specified in the periodic maintenance and lubrication chart.

EBU27470

## Checking the front and rear brake pads

The front and rear brake pads must be checked for wear at the intervals specified in the periodic maintenance and lubrication chart. Each brake pad is provided with a wear indicator groove, which allows you to check the brake pad wear without having to disassemble the brake. If a brake pad has worn to the point that the wear indicator groove has almost disappeared, have a Yamaha dealer replace the brake pads as a set.

### TIP

The wheels need to be removed to check the brake pads. (See page 8-64.)

## Front brake

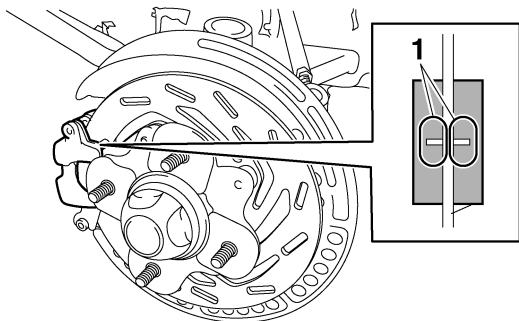

1. Wear indicator groove

## Rear brake

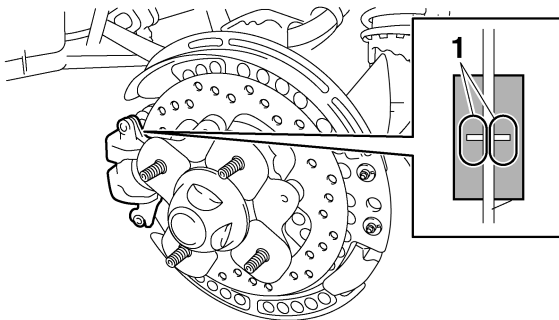

1. Wear indicator groove

EBU27842

## Checking the rear brake hose protectors

The rear brake hoses protectors must be checked for wear at the intervals specified in the periodic maintenance and lubrication chart. Each brake hose protector is provided with a wear indicator. If a protector wears to the point that its indicator becomes visible, have a Yamaha dealer replace the protector.

### TIP

The wheels need to be removed to check the brake hose protectors. (See page 8-64.)

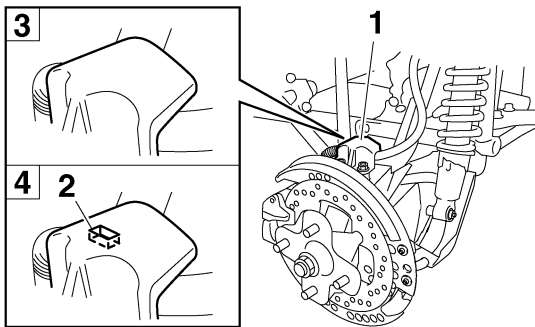

1. Rear brake hose protector
2. Wear indicator
3. Protector is normal.
4. Protector is worn.

8

EBU24251

## Checking the brake fluid level

Insufficient brake fluid may allow air to enter the brake system, possibly causing it to become ineffective.

Before riding, check that the brake fluid is above the minimum level mark and replenish if necessary. A low brake fluid level may indicate worn brake pads and/or brake system leakage. If the brake fluid level is low, be sure to check the brake pads for wear and the brake system for leakage.

### Front brake

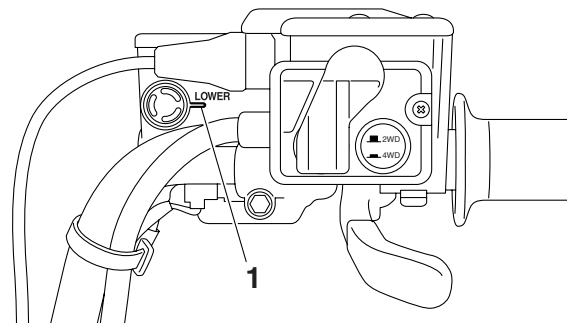

1. Minimum level mark

### Rear brake

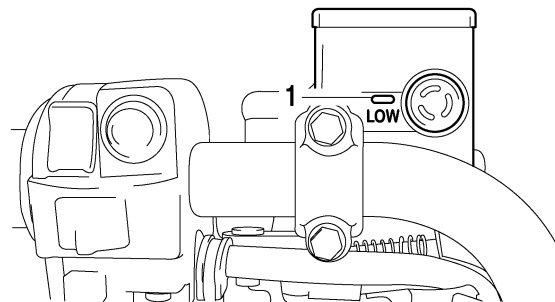

1. Minimum level mark

Observe these precautions:

- When checking the fluid level, make sure that the top of the brake fluid reservoir is level.
- Use only the recommended quality brake fluid, otherwise the rubber seals may deteriorate, causing leakage and poor braking performance.

Recommended brake fluid: DOT 4
-----------------------------------

- Refill with the same type of brake fluid. Mixing fluids may result in a harmful chemical reaction and lead to poor braking performance.
- Be careful that water does not enter the brake fluid reservoir when refilling. Water will significantly lower the boiling point of the fluid and may result in vapor lock.
- Brake fluid may deteriorate painted surfaces or plastic parts. Always clean up spilled fluid immediately.
- As the brake pads wear, it is normal for the brake fluid level to gradually go down. However, if the brake fluid level goes down suddenly, have a Yamaha dealer check the cause.

EBU24291

## Changing the brake fluid

Have a Yamaha dealer change the brake fluid at the intervals specified in the TIP after the periodic maintenance and lubrication chart. In addition, have the oil seals of the master cylinders and calipers as well as the brake hoses replaced at the intervals listed below or whenever they are damaged or leaking.

- Oil seals: Replace every two years.
- Brake hoses: Replace every four years.

EBU27531

## Checking the front and rear brake lever free play

The front and rear brake lever free play must be checked at the intervals specified in the periodic maintenance and lubrication chart. The brake levers should have no free play as shown. If there is free play, have a Yamaha dealer check the brake system.

## Front brake

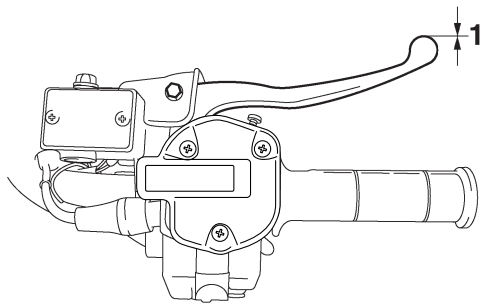

1. Brake lever free play

## Rear brake

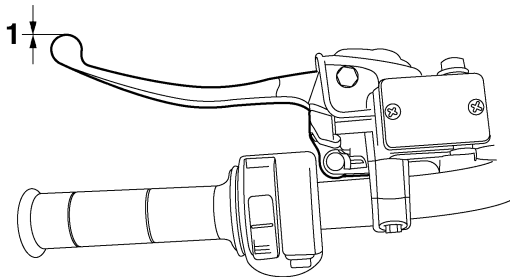

1. Brake lever free play

EWB02460

### **WARNING**

#### **POTENTIAL HAZARD**

Operating with improperly serviced or adjusted brakes.

#### **WHAT CAN HAPPEN**

You could lose braking ability, which could lead to an accident.

#### **HOW TO AVOID THE HAZARD**

After servicing:

- Make sure the brakes operate smoothly and that there is no free play.
- Make sure the brakes do not drag.
- Make sure the brakes are not spongy. All air must be bled from the brake system.

Replacement of brake components requires professional knowledge. These procedures should be performed by a Yamaha dealer.

EBU29021

### **Adjusting the brake pedal free play**

The brake pedal free play must be adjusted at the intervals specified in the periodic maintenance and lubrication chart.

## TIP

- Always perform this maintenance completely in the following order whenever adjusting the rear brake.
- Before adjusting the brake pedal free play, check the rear brake pads for wear.

The brake pedal free play should measure 0.0–5.0 mm (0.00–0.20 in) as shown. If the free play is incorrect, adjust it as follows.

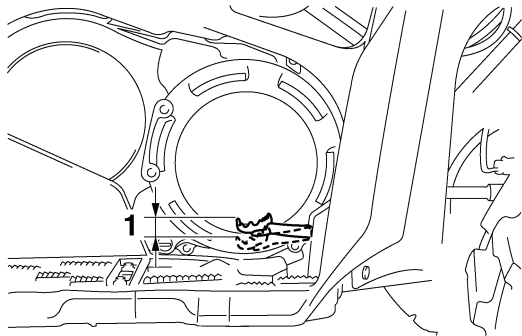

1. Brake pedal free play

1. Remove panel H. (See page 8-8.)
2. Loosen the locknut.

3. Turn the brake pedal free play adjusting nut in direction (a) to increase the free play, and in direction (b) to decrease it.

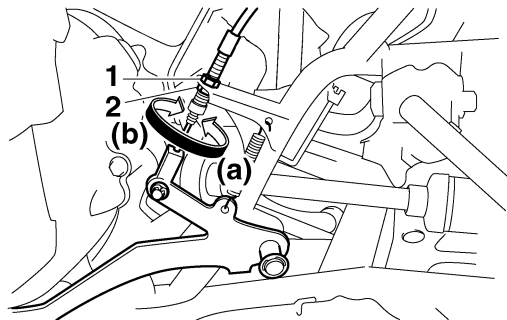

1. Locknut
2. Brake pedal free play adjusting nut

4. Tighten the locknut.
5. After adjusting, there should be slight play at the brake pedal cable joint as shown. If there is no play, repeat steps 2 to 4.

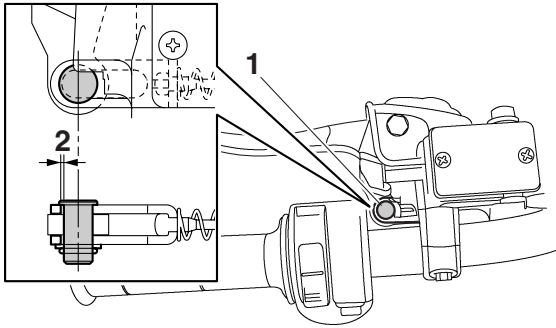

1. Brake pedal cable joint
2. Slight play

6. Install the panel.

If the correct free play cannot be obtained, have a Yamaha dealer adjust it.

#### **TIP** \_\_\_\_\_

When adjusting the rear brake pedal free play:

- Be sure not to step on the brake pedal.
  - Make sure the rear brake lever and brake pedal do not move.
- 

## **⚠ WARNING**

### **POTENTIAL HAZARD**

**Operating with improperly serviced or adjusted brakes.**

### **WHAT CAN HAPPEN**

**You could lose braking ability, which could lead to an accident.**

### **HOW TO AVOID THE HAZARD**

**After servicing:**

- **Make sure the brakes operate smoothly and that the free play is correct.**
- **Make sure the brakes do not drag.**
- **Make sure the brakes are not spongy. All air must be bled from the brake system.**

**Replacement of brake components requires professional knowledge. These procedures should be performed by a Yamaha dealer.**

## **Axle boots**

The axle boots must be checked for damage at the intervals specified in the periodic maintenance and lubrication chart. Check the axle boots for tears or damage. If any damage is found, have them replaced by a Yamaha dealer.



## Checking and lubricating the cables

The operation and the condition of all control cables should be checked before each ride, and the cables and cable ends should be lubricated if necessary. If a cable is damaged or does not move smoothly, have a Yamaha dealer check or replace it.

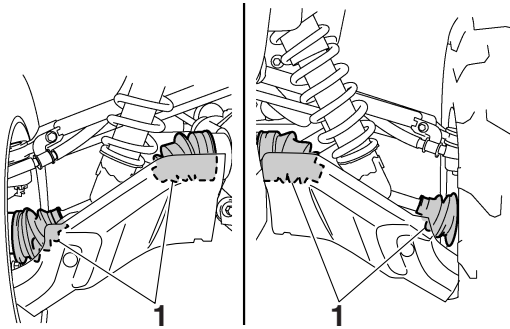

1. Front axle boot (each side)

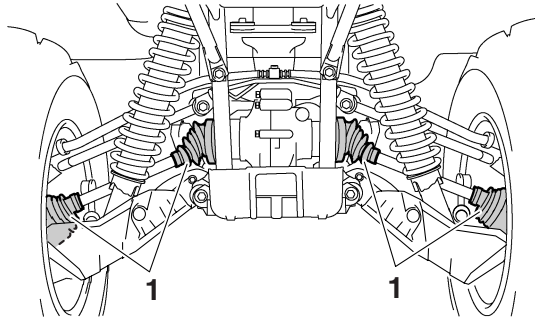

1. Rear axle boot (each side)

Recommended lubricant:  
Engine oil

### WARNING

#### POTENTIAL HAZARD

**Damaged control cables.**

#### WHAT CAN HAPPEN

Corrosion can result when the cable sheaths become damaged, and cables can also become frayed or kinked, which could restrict the operation of controls and lead to an accident or injury.

#### HOW TO AVOID THE HAZARD

Inspect cables frequently. Replace damaged cables.

## Checking and lubricating the front and rear brake levers

The operation of the front and rear brake levers should be checked before each ride, and the lever pivots should be lubricated if necessary.

Recommended lubricant:  
Silicone grease

### Front brake lever

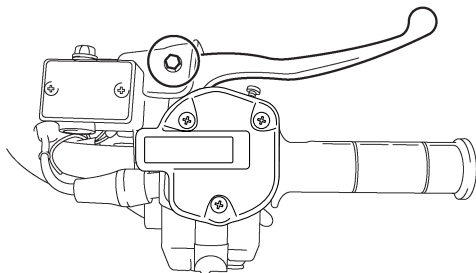

### Rear brake lever

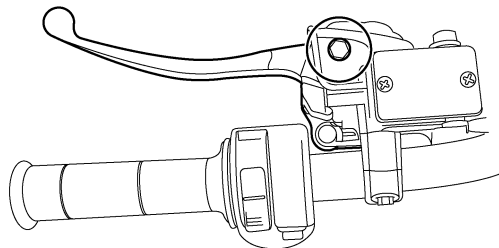

## Checking and lubricating the brake pedal

The operation of the brake pedal should be checked before each ride, and the pedal pivot should be lubricated if necessary.

### TIP

To access the brake pedal pivot, remove panel H.  
(See page 8-8.)

Recommended lubricant:  
Lithium-soap-based grease

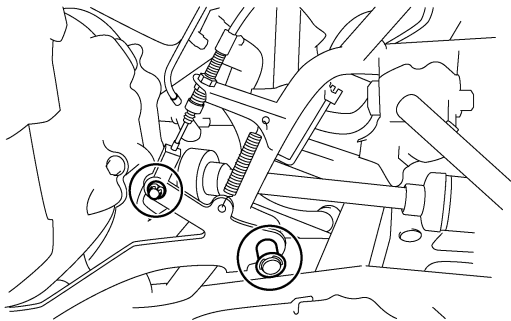

EBU24962

### Checking the wheel hub bearings

The front and rear wheel hub bearings must be checked at the intervals specified in the periodic maintenance and lubrication chart. If there is play in a wheel hub or if a wheel does not turn smoothly, have a Yamaha dealer check the wheel hub bearings.

EBU25021

### Checking the stabilizer bushes

The stabilizer bushes must be checked for cracks or damage at the intervals specified in the periodic maintenance and lubrication chart.

Have a Yamaha dealer replace the stabilizer bushes if necessary.

EBU25051

### Lubricating the rear knuckle pivots

The rear knuckle pivots must be lubricated at the intervals specified in the periodic maintenance and lubrication chart.

Lubricate the pivoting points using a grease gun.

Recommended lubricant:  
Lithium-soap-based grease

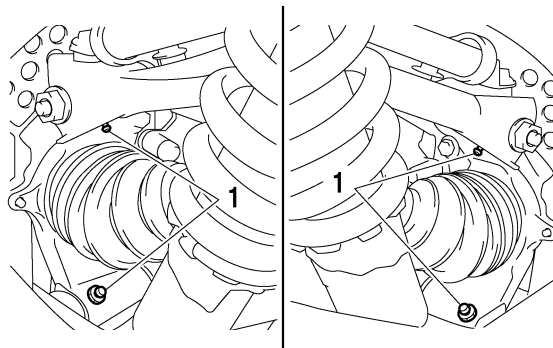

1. Grease nipple

## Lubricating the steering shaft

The steering shaft must be lubricated at the intervals specified in the periodic maintenance and lubrication chart.

Recommended lubricant:  
Lithium-soap-based grease

## Battery

This model is equipped with a VRLA (Valve Regulated Lead Acid) battery. There is no need to check the electrolyte or to add distilled water. However, the battery lead connections need to be checked and, if necessary, tightened.

### **NOTICE**

**Never attempt to remove the battery cell seals, as this would permanently damage the battery.**



### **WARNING**

#### **POTENTIAL HAZARD**

**Failure to handle batteries or battery electrolyte carefully.**

### **WHAT CAN HAPPEN**

You could be poisoned. You could be severely burned by the sulfuric acid in battery electrolyte. Batteries produce explosive gases.

### **HOW TO AVOID THE HAZARD**

**Avoid contact with skin, eyes or clothing. Always shield eyes when working near batteries. Keep out of reach of children.**

**Antidote:**

**EXTERNAL:** Flush with water.

**INTERNAL:** Drink large quantities of water or milk. Follow with milk of magnesia, beaten egg or vegetable oil. Get prompt medical attention.

**EYES:** Flush with water for 15 minutes and get prompt medical attention. Keep batteries away from sparks, flames, cigarettes or other sources of ignition. Ventilate when charging or using in a closed space.

### **To remove the battery**

1. Remove panel A. (See page 8-8.)
2. Remove the front carrier by removing the bolts.

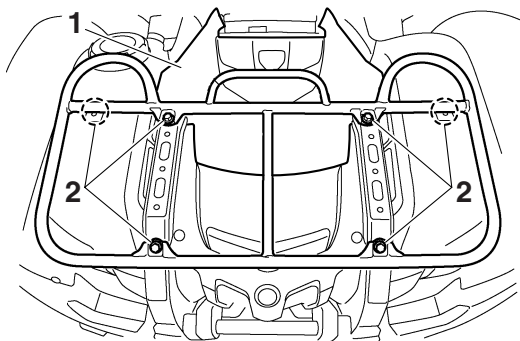

1. Panel A

2. Bolt

3. Remove the battery holding plate by removing the nuts.
4. Disconnect the negative battery lead first, then the positive battery lead by removing their bolt.

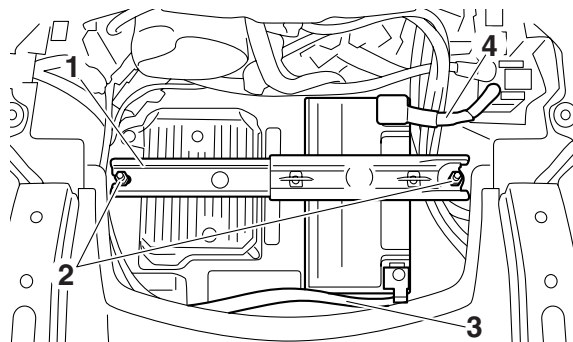

1. Battery holding plate

2. Nut

3. Negative battery lead (black)

4. Positive battery lead (red)

5. Pull the battery out of its compartment.

### To charge the battery

Have a Yamaha dealer charge the battery as soon as possible if it seems to have discharged. Keep in mind that the battery tends to discharge more quickly if the ATV is equipped with optional electrical accessories.

## To store the battery

- If the ATV will not be used for more than one month, remove the battery, fully charge it, and then place it in a cool, dry place.
- If the battery will be stored for more than two months, check it at least once a month and fully charge it if necessary.

## To install the battery

### TIP

Be sure the battery is fully charged.

1. Place the battery in its compartment.
2. Connect the positive battery lead first, then the negative battery lead by installing their bolt.

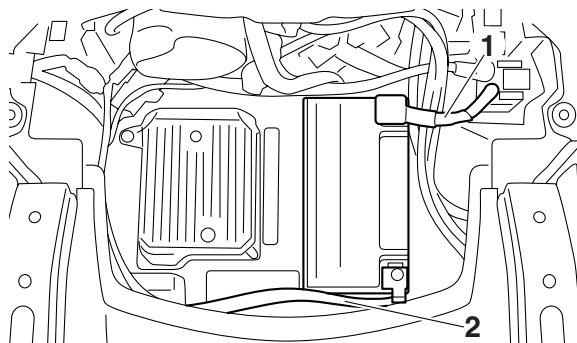

1. Positive battery lead (red)

2. Negative battery lead (black)

3. Install the battery holding plate by installing the nuts.
4. Install the front carrier by installing the bolts.
5. Install the panel.

ECB00632

### NOTICE

- **Always keep the battery charged. Storing a discharged battery can cause permanent battery damage.**
- **To charge a VRLA (Valve Regulated Lead Acid) battery, a special (constant-voltage) battery charger is required. Using a conventional battery charger will damage**

the battery. If you do not have access to a constant-voltage battery charger, have a Yamaha dealer charge your battery.

EBU27580

## Replacing a fuse

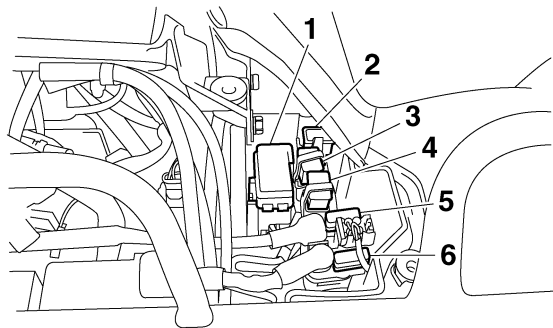

1. Fuse box
2. Main/EPS spare fuse
3. Main fuse
4. EPS fuse (for EPS model)
5. Fuel injection system spare fuse
6. Fuel injection system fuse

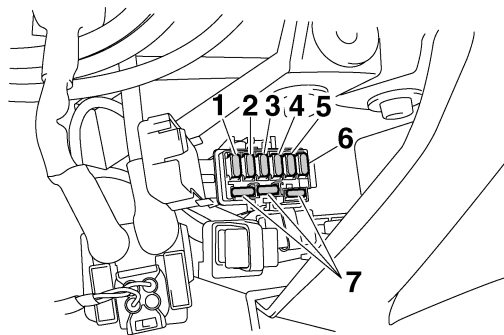

1. Ignition fuse
2. Headlight fuse
3. Four-wheel-drive motor fuse
4. Radiator fan fuse
5. Signaling system fuse
6. Auxiliary DC jack fuse
7. Spare fuse

The main fuse, the fuel injection system fuse, the EPS fuse, and the fuse box are located under panel A. (See page 8-8.)

If a fuse is blown, replace it as follows.

1. Turn the key to "OFF" and turn off all electrical circuits.

**NOTICE**

**To prevent accidental short-circuiting, turn off the main switch when checking or replacing a fuse.**

2. Remove the blown fuse, and then install a new fuse of the specified amperage.

## Specified fuses:

Main fuse:

40.0 A

Headlight fuse:

15.0 A

Ignition fuse:

15.0 A

Four-wheel-drive motor fuse:

15.0 A

Signaling system fuse:

5.0 A

Auxiliary DC jack fuse:

15.0 A

Radiator fan fuse:

20.0 A

Fuel injection system fuse:

15.0 A

EPS fuse:

YFM5FGPY 40.0 A

**POTENTIAL HAZARD****Using an improper fuse.**



## **WHAT CAN HAPPEN**

**An improper fuse can cause damage to the electrical system, which could lead to a fire.**

## **HOW TO AVOID THE HAZARD**

**Always use a fuse of the specified rating.  
Never use a material in place of the proper fuse.**

3. Turn the key to “ON” and turn on the electrical circuits to check if the devices operate.
4. If the fuse immediately blows again, have a Yamaha dealer check the electrical system.

EBU27430

## **Replacing a headlight bulb**

If a headlight bulb burns out, replace it as follows.

1. Remove the cover at the rear of the headlight by pulling it off.

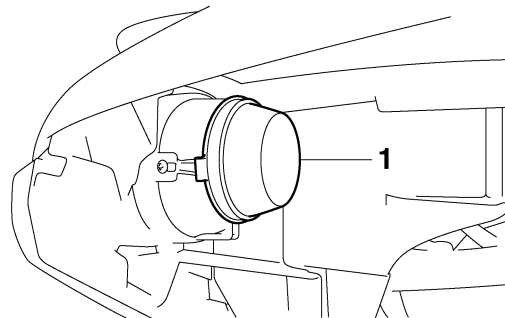

1. Cover at the rear of the headlight
2. Remove the headlight bulb cover.

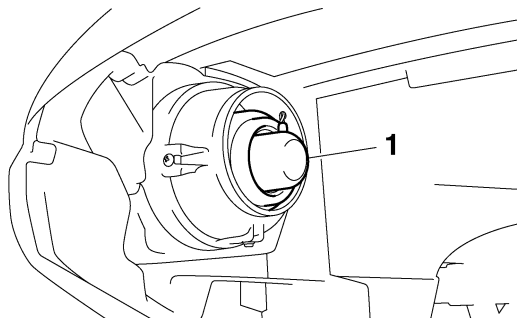

1. Headlight bulb cover
3. Disconnect the headlight coupler.

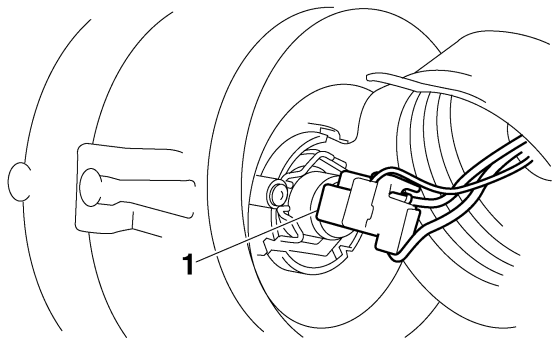

1. Headlight coupler

4. Unhook the headlight bulb holder, and then remove the defective bulb.

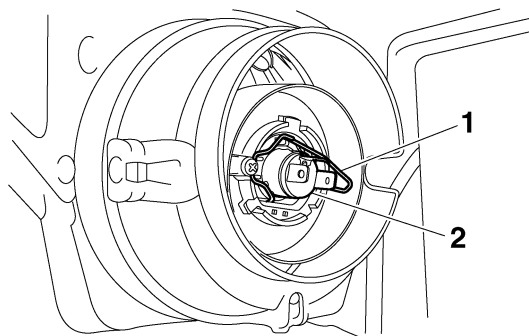

1. Headlight bulb holder

2. Headlight bulb

EWB02180

**⚠ WARNING**

**POTENTIAL HAZARD**

**A headlight bulb is hot when it is on and immediately after it is turned off.**

**WHAT CAN HAPPEN**

**You can be burned, or a fire could start if the bulb touches something flammable.**

**HOW TO AVOID THE HAZARD**

**Wait for the bulb to cool before touching or removing it.**

5. Place a new headlight bulb into position, and then secure it with the bulb holder.

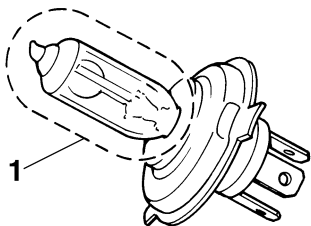

1. Do not touch the glass part of the bulb.

ECB00650

### **NOTICE**

**Do not touch the glass part of the headlight bulb to keep it free from oil, otherwise the transparency of the glass, the luminosity of the bulb, and the bulb life will be adversely affected. Thoroughly clean off any dirt and fingerprints on the headlight bulb using a cloth moistened with alcohol or thinner.**

6. Connect the headlight coupler.
7. Install the headlight bulb cover.
8. Install the cover at the rear of the headlight.

ECB00670

### **NOTICE**

**Make sure the headlight bulb holder cover is securely fitted over the bulb holder and seated properly.**

9. Adjust the headlight beam if necessary.

EBU25551

## **Adjusting a headlight beam**

ECB00690

### **NOTICE**

**It is advisable to have a Yamaha dealer make this adjustment.**

To raise a headlight beam, turn the headlight beam adjusting screw in direction (a).

To lower a headlight beam, turn the adjusting screw in direction (b).

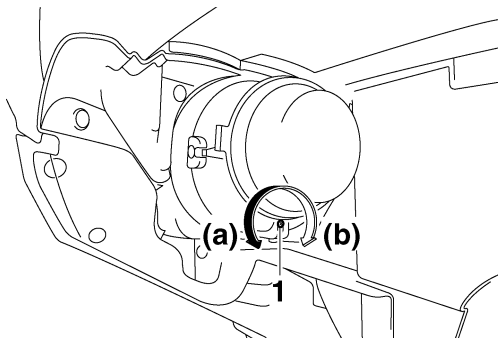

1. Headlight beam adjusting screw

EBU25640

## Replacing the tail/brake light bulb

If the tail/brake light bulb burns out, replace it as follows.

1. Remove panel I. (See page 8-8.)
2. Remove the bulb holder (together with the bulb) by turning it counterclockwise.

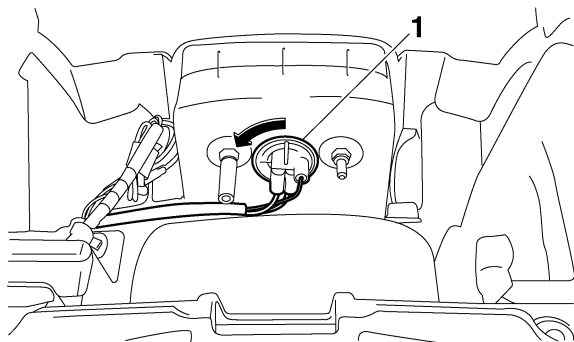

1. Tail/brake light bulb holder

3. Remove the defective bulb by pushing it in and turning it counterclockwise.

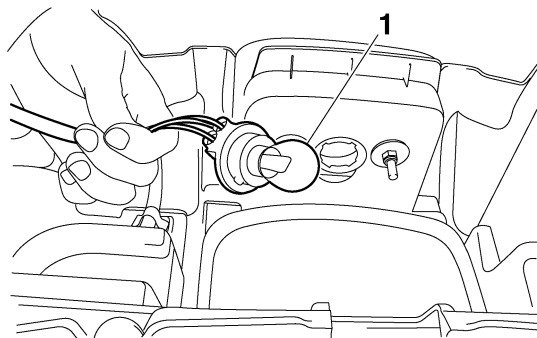

1. Tail/brake light bulb

4. Insert a new bulb into the bulb holder, push it in, and then turn it clockwise until it stops.
5. Install the bulb holder (together with the bulb) by turning it clockwise.
6. Install the panel.

EBU25651

## Removing a wheel

1. Place the ATV on a level surface.
2. Loosen the wheel nuts.

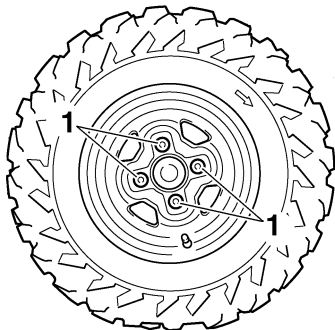

1. Wheel nut

3. Elevate the ATV and place a suitable stand under the frame.
4. Remove the nuts from the wheel.
5. Remove the wheel.

EBU25701

## Installing a wheel

1. Place the ATV on a level surface.
2. Install the wheel and the nuts.

### TIP

- The arrow mark ⇨ on the tire must point toward the rotating direction of the wheel.
- Tapered nuts are used for both the front and rear wheels. Install the nuts with their tapered side towards the wheel.

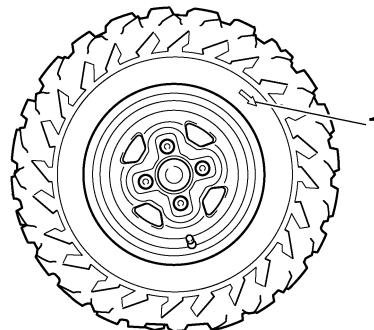

1. Arrow mark

## Troubleshooting

Although Yamaha ATVs receive a thorough inspection before shipment from the factory, trouble may occur during operation. Any problem in the fuel, compression, or ignition systems, for example, can cause poor starting and loss of power.

The following troubleshooting charts represent quick and easy procedures for checking these vital systems yourself. However, should your ATV require any repair, take it to a Yamaha dealer, whose skilled technicians have the necessary tools, experience, and know-how to service the ATV properly. Use only genuine Yamaha replacement parts. Imitation parts may look like Yamaha parts, but they are often inferior, have a shorter service life and can lead to expensive repair bills.

EWB02260

### WARNING

#### POTENTIAL HAZARD

**Checking the fuel system while smoking or near an open flame.**

#### WHAT CAN HAPPEN

**Fuel can ignite or explode, causing severe injury or property damage.**

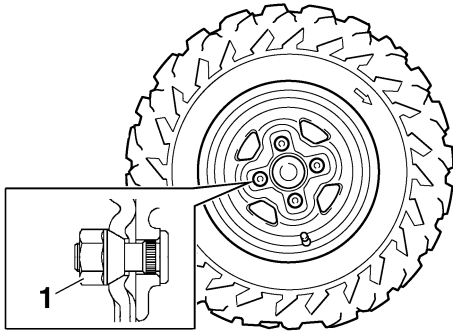

1. Tapered nut
3. Lower the ATV to the ground.
4. Tighten the wheel nuts to the specified torques.

#### Tightening torques:

Front wheel nut:

55 Nm (5.5 m·kgf, 40 ft·lbf)

Rear wheel nut:

55 Nm (5.5 m·kgf, 40 ft·lbf)

### **HOW TO AVOID THE HAZARD**

**Do not smoke when checking the fuel system. Make sure there are no open flames or sparks in the area, including pilot lights from water heaters or furnaces.**

# Troubleshooting charts

## Starting problems or poor engine performance

### 1. Fuel

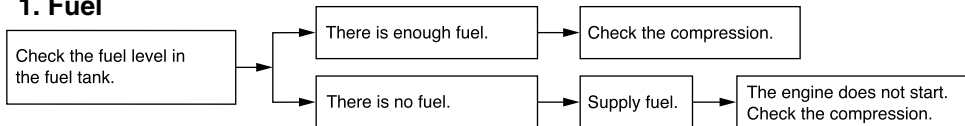

### 2. Compression

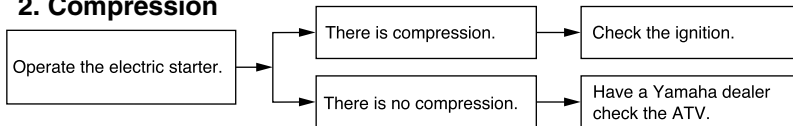

### 3. Ignition

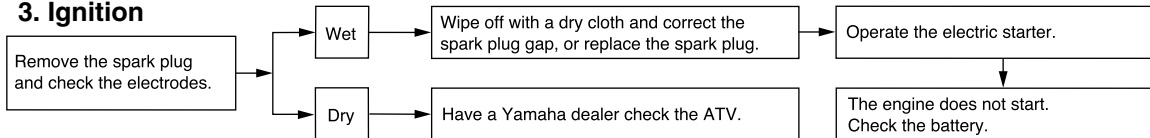

### 4. Battery

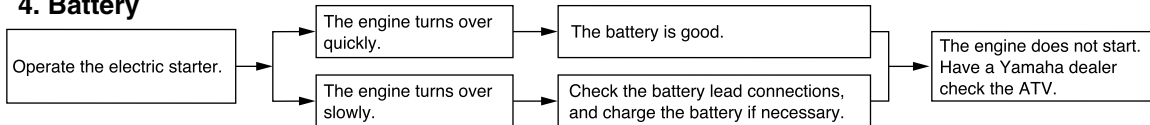



## Engine overheating

EWB02270

### WARNING

#### POTENTIAL HAZARD

Removing the radiator cap when the engine and radiator are still hot.

#### WHAT CAN HAPPEN

You could be burned by hot fluid and steam blown out under pressure.

#### HOW TO AVOID THE HAZARD

Wait for the engine to cool before removing the radiator cap. Always use a thick rag over the cap.

Allow any remaining pressure to escape before completely removing the cap.

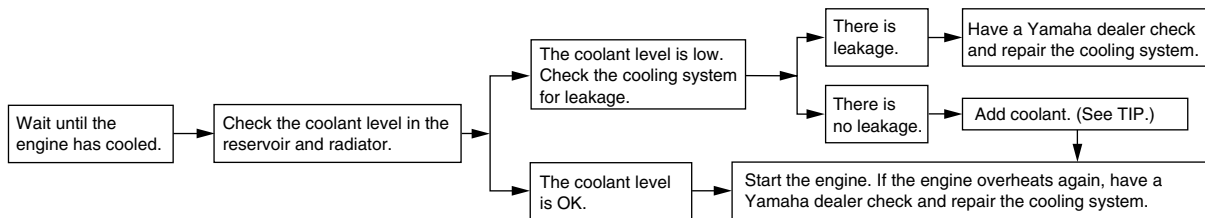

8

#### TIP

If coolant is not available, tap water can be temporarily used instead, provided that it is changed to the recommended coolant as soon as possible.

## CLEANING AND STORAGE

EBU25870

### Cleaning

Frequent, thorough cleaning of your ATV will not only enhance its appearance but will improve its general performance and extend the useful life of many components.

1. Before cleaning the ATV:
  - a. Block off the end of the exhaust pipe to prevent water entry. A plastic bag and strong rubber band may be used.
  - b. Make sure the spark plug and all filler caps are properly installed.
2. If the engine case is excessively greasy, apply degreaser with a paint brush. Do not apply degreaser to the wheel axles.
3. Rinse the dirt and degreaser off with a garden hose. Use only enough pressure to do the job.

ECB00710

#### **NOTICE**

**Excessive water pressure may cause water seepage and deterioration of wheel bearings, brakes, transmission seals and electrical devices. Many expensive repair bills have result-**

**ed from improper high-pressure detergent applications such as those available in coin-operated car washers.**

4. Once most of the dirt has been hosed off, wash all surfaces with warm water and mild, detergent-type soap. An old toothbrush or bottle brush is handy for hard-to-reach places.
5. Rinse the ATV off immediately with clean water and dry all surfaces with a chamois, clean towel or soft absorbing cloth.
6. Clean the seat with a vinyl upholstery cleaner to keep the cover pliable and glossy.
7. Automotive type wax may be applied to all painted and chrome plated surfaces. Avoid combination cleaner-waxes. Many contain abrasives which may mar the paint or protective finish. When finished cleaning, start the engine and let it idle for several minutes.

EWB02300



**WARNING**

#### **POTENTIAL HAZARD**

**Operation with wet brakes after washing.**

## **WHAT CAN HAPPEN**

**Wet brakes may have reduced stopping ability, increasing the chance of an accident.**

## **HOW TO AVOID THE HAZARD**

**Test the brakes after washing. Apply the brakes several times at slow speeds to let friction dry out the linings.**

EBU27260

## **Storage**

### **Short-term**

Always store your ATV in a cool, dry place and, if necessary, protect it against dust with a porous cover.

ECB00720

### **NOTICE**

- **Storing the ATV in a poorly ventilated room or covering it with a tarp while it is still wet, will allow water and humidity to seep in and cause rust.**
- **To prevent corrosion, avoid damp cellars, stables (because of the presence of ammonia) and areas where strong chemicals are stored.**

## **Long-term**

Before storing your ATV for several months:

1. Follow all the instructions in the “Cleaning” section of this chapter.
2. Fill up the fuel tank and add fuel stabilizer (if available) to prevent the fuel from deteriorating.

Specified amount:

7.5 ml of stabilizer to each liter of fuel (or 1 oz of stabilizer to each gallon of fuel)

3. Perform the following steps to protect the cylinder, piston rings, etc. from corrosion.
  - a. Remove the spark plug cap and spark plug.
  - b. Pour a teaspoonful of engine oil into the spark plug bore.
  - c. Install the spark plug cap onto the spark plug, and then place the spark plug on the cylinder head so that the electrodes are grounded. (This will limit sparking during the next step.)
  - d. Turn the engine over several times with the starter. (This will coat the cylinder wall with oil.)

- e. Remove the spark plug cap from the spark plug, and then install the spark plug and the spark plug cap.
4. Lubricate all control cables and the pivoting points of all levers and pedals.
5. Check and, if necessary, correct the tire air pressure, and then block up the ATV so that all of its wheels are off the ground. Alternatively, turn the wheels a little every month in order to prevent the tires from becoming degraded in one spot.
6. Cover the muffler outlet with a plastic bag to prevent moisture from entering it.
7. Remove the battery and fully charge it. Store it in a cool, dry place and charge it once a month. Do not store the battery in an excessively cold or warm place [less than 0 °C (30 °F) or more than 30 °C (90 °F)]. For more information on storing the battery, see page 8-55.

**TIP**

---

Make any necessary repairs before storing the ATV.

---

# SPECIFICATIONS

## Dimensions:

- Overall length:  
2065 mm (81.3 in)
- Overall width:  
1180 mm (46.5 in)
- Overall height:  
1240 mm (48.8 in)
- Seat height:  
905 mm (35.6 in)
- Wheelbase:  
1250 mm (49.2 in)
- Ground clearance:  
275 mm (10.8 in)
- Minimum turning radius:  
3200 mm (126 in)

## Weight:

- With oil and fuel:  
294.0 kg (648 lb)

## Engine:

- Engine type:  
Liquid cooled 4-stroke, SOHC
- Cylinder arrangement:  
Forward-inclined single cylinder
- Displacement:  
558.0 cm<sup>3</sup>
- Bore × stroke:  
92.0 × 84.0 mm (3.62 × 3.31 in)

Compression ratio:

9.30 :1

Starting system:

Electric starter

Lubrication system:

Wet sump

## Engine oil:

Type:

YAMALUBE 4 5W-30 or 10W-40 or 20W-50, SAE 5W-30  
or SAE 10W-40 or SAE 20W-50

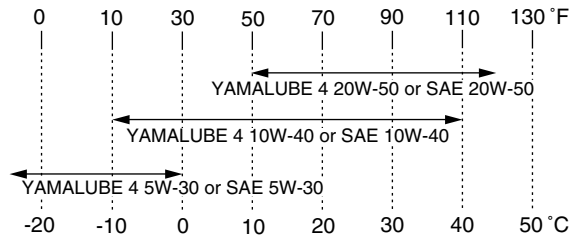

Recommended engine oil grade:

API service SG type or higher, JASO standard MA

Engine oil quantity:

Without oil filter cartridge replacement:

2.00 L (2.11 US qt, 1.76 Imp.qt)

With oil filter cartridge replacement:

2.10 L (2.22 US qt, 1.85 Imp.qt)

### **Final gear oil:**

Type:

SAE 80 API GL-4 Hypoid gear oil

Quantity:

0.20 L (0.21 US qt, 0.18 Imp.qt)

### **Differential gear oil:**

Type:

SAE 80 API GL-4 Hypoid gear oil

Quantity:

0.22 L (0.23 US qt, 0.19 Imp.qt)

### **Cooling system:**

Coolant reservoir capacity (up to the maximum level mark):

0.24 L (0.25 US qt, 0.21 Imp.qt)

Radiator capacity (including all routes):

1.99 L (2.10 US qt, 1.75 Imp.qt)

### **Air filter:**

Air filter element:

Wet element

### **Fuel:**

Recommended fuel:

Unleaded gasoline only

Fuel tank capacity:

20.0 L (5.28 US gal, 4.40 Imp.gal)

Fuel reserve amount:

4.5 L (1.19 US gal, 0.99 Imp.gal)

### **Fuel injection:**

Throttle body:

Type/quantity:

40EIS/1

Manufacturer:

MIKUNI

### **Spark plug (s):**

Manufacturer/model:

NGK/LMAR6A-9

Spark plug gap:

0.8–0.9 mm (0.031–0.035 in)

### **Clutch:**

Clutch type:

Wet, centrifugal automatic

### **Transmission:**

Primary reduction system:

V-belt

Secondary reduction system:

Shaft drive

Secondary reduction ratio:

$41/21 \times 24/18 \times 33/9$  (9.544)

Transmission type:

V-belt automatic

Operation:

Left hand operation

Reverse gear:

$23/14 \times 28/23$  (2.000)

Low range:

31/16 (1.938)

High range:

31/27 (1.148)

**Chassis:**

Frame type:

Steel tube frame

Caster angle:

5.0 °

Trail:

26.0 mm (1.02 in)

**Front tire:**

Type:

Tubeless

Size:

AT25 x 8-12

Manufacturer/model:

DUNLOP/KT421

**Rear tire:**

Type:

Tubeless

Size:

AT25 x 10-12

Manufacturer/model:

DUNLOP/KT425

**Loading:**

Maximum loading limit:

220.0 kg (485 lb)

(Total weight of rider, cargo, accessories, and tongue)

**Tire air pressure (measured on cold tires):**

Recommended:

Front:

35.0 kPa (0.350 kgf/cm<sup>2</sup>, 5.0 psi)

Rear:

30.0 kPa (0.300 kgf/cm<sup>2</sup>, 4.4 psi)

Minimum:

Front:

32.0 kPa (0.320 kgf/cm<sup>2</sup>, 4.6 psi)

Rear:

27.0 kPa (0.270 kgf/cm<sup>2</sup>, 4.0 psi)**Front wheel:**

Wheel type:

Panel wheel

Rim size:

12 x 6.0AT

**Rear wheel:**

Wheel type:

Panel wheel

Rim size:

12 x 7.5AT

**Front brake:**

Type:

Dual disc brake

Operation:

Right hand operation

Recommended fluid:

DOT 4

**Rear brake:**

Type:

Dual disc brake

Operation:

Left hand and right foot operation

Recommended fluid:

DOT 4

## Front suspension:

Type:

Double wishbone

Spring/shock absorber type:

Coil spring/oil damper

Wheel travel:

180 mm (7.1 in)

## Rear suspension:

Type:

Double wishbone

Spring/shock absorber type:

Coil spring/oil damper

Wheel travel:

230 mm (9.1 in)

## Electrical system:

Ignition system:

TCI (digital)

Charging system:

AC magneto

## Battery:

Model:

YTX20L-BS

Voltage, capacity:

12 V, 18.0 Ah

## Headlight:

Bulb type:

Halogen bulb

## Bulb voltage, wattage × quantity:

Headlight:

12 V, 35.0/35.0 W × 2

Tail/brake light:

12 V, 5.0/21.0 W

Meter lighting:

EL

Neutral indicator light:

LED

Reverse indicator light:

LED

Coolant temperature warning light:

LED

Engine trouble warning light:

LED

EPS warning light:

YFM5FGPY LED

Park indicator light:

LED

On-Command four-wheel-drive/differential gear lock indicator:

LCD

High-range indicator light:

LED

Low-range indicator light:

LED

Differential gear lock indicator light:

LED

## Fuses:

Main fuse:

40.0 A

Fuel injection system fuse:

15.0 A

EPS fuse:

YFM5FGPY 40.0 A



Headlight fuse:

15.0 A

Signaling system fuse:

5.0 A

Ignition fuse:

15.0 A

Auxiliary DC jack fuse:

15.0 A

Four-wheel-drive motor fuse:

15.0 A

Radiator fan fuse:

20.0 A

## CONSUMER INFORMATION

EBU26011

### Identification numbers

Record the key identification number, vehicle identification number and model label information in the spaces provided below for assistance when ordering spare parts from a Yamaha dealer or for reference in case the ATV is stolen.

KEY IDENTIFICATION NUMBER:

VEHICLE IDENTIFICATION NUMBER:

MODEL LABEL INFORMATION:



EBU26020

### Key identification number

The key identification number is stamped into the key. Record this number in the space provided and use it for reference when ordering a new key.

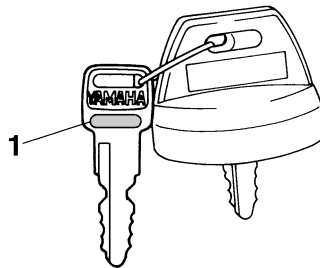

1. Key identification number

EBU26030

### Vehicle identification number

The vehicle identification number is stamped into the frame.

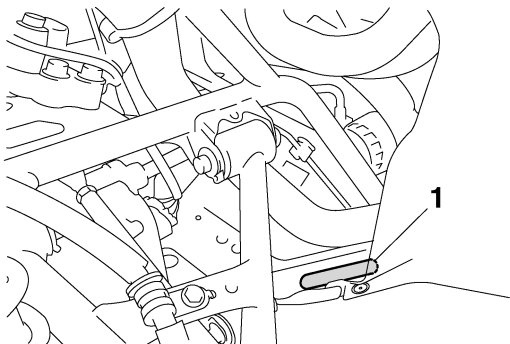

1. Vehicle identification number (front left side)

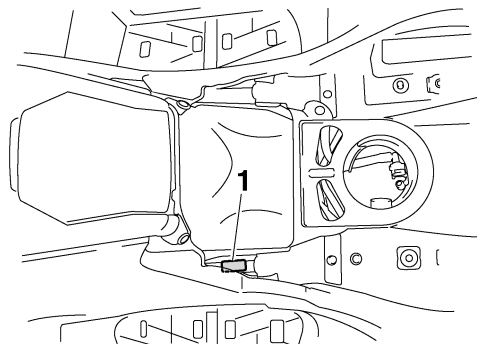

1. Model label

## **TIP**

The vehicle identification number is used to identify your ATV.

EBU26050

## **Model label**

The model label is affixed at the location in the illustration. Record the information on this label in the space provided. This information will be needed when ordering spare parts from a Yamaha dealer.

## Noise regulation

### TAMPERING WITH NOISE CONTROL SYSTEM PROHIBITED:

Federal law prohibits the following acts or the causing thereof: (1) The removal or rendering inoperative by any person other than for purposes of maintenance, repair, or replacement of any device or element of design incorporated into any new vehicle for the purpose of noise control prior to its sale or delivery to the ultimate purchaser or while it is in use or (2) the use of the vehicle after such device or element of design has been removed or rendered inoperative by any person.

“AMONG THOSE ACTS PRESUMED TO CONSTITUTE TAMPERING ARE THE ACTS LISTED BELOW”.

These acts include tampering with the following systems; i.e., modification, removal, etc.

**Exhaust system**

- Muffler
- Exhaust pipe
- Silencer

**Intake system**

- Air cleaner case
- Air cleaner element
- Intake duct

## Maintenance record

Copies of work orders and/or receipts for parts you purchase and install will be required to document maintenance done in accordance with the warranty. The chart below is printed only as a reminder to you that the maintenance work is required. It is not acceptable proof of maintenance work.

MAINTENANCE INTERVAL			DATE OF SERVICE	MILEAGE	SERVICING DEALER NAME AND ADDRESS	REMARKS
month	km (mi)	hours				
1	320 (200)	20				
3	1300 (800)	80				
6	2500 (1600)	160				
12	5000 (3200)	320				
18	7500 (4800)	480				
24	10000 (6400)	640				
30	12500 (8000)	800				
36	15000 (9600)	960				
42	17500 (11200)	1120				
48	20000 (12800)	1280				
54	22500 (14400)	1440				
60	25000 (16000)	1600				

# YAMAHA MOTOR CORPORATION, U.S.A. ATV LIMITED WARRANTY

Yamaha Motor Corporation, U.S.A. hereby warrants that new Yamaha ATVs purchased from an authorized Yamaha ATV dealer in the continental United States will be free from defects in material and workmanship for the period of time stated herein, subject to certain stated limitations.

**THE PERIOD OF WARRANTY** for Yamaha ATVs shall be six (6) months from the date of purchase.

**DURING THE PERIOD OF WARRANTY** any authorized Yamaha ATV dealer will, free of charge, repair or replace any part adjudged defective by Yamaha due to faulty workmanship or material from the factory. Parts used in warranty repairs will be warranted for the balance of the product's warranty period. All parts replaced under warranty become property of Yamaha Motor Corp. U.S.A.

**GENERAL EXCLUSIONS** from this warranty shall include any failures caused by:

- a. Competition or racing use.
- b. Installation of parts or accessories that are not qualitatively equivalent to genuine Yamaha parts.
- c. Abnormal strain, neglect, or abuse.
- d. Lack of proper maintenance.
- e. Accident or collision damage.
- f. Modification to original parts.
- g. Damage due to improper transportation.

**SPECIFIC EXCLUSIONS** from this warranty shall include parts replaced due to normal wear or routine maintenance, such as spark plugs, oil, oil filter, air filter, and brake shoes.

**THE CUSTOMER'S RESPONSIBILITY** under this warranty shall be to:

1. Operate and maintain the ATV as specified in the appropriate owner's manual;
2. Give notice to an authorized Yamaha ATV dealer of any and all apparent defects within ten (10) days after discovery, and make the machine available at that time for inspection and repairs at such dealer's place of business.

**WARRANTY TRANSFER:** To transfer the warranty from the original purchaser to any subsequent purchaser(s), it is imperative that the machine be inspected and registered for warranty by an authorized Yamaha ATV dealer. In order for this warranty to remain in effect, this inspection and registration must take place within ten (10) days after transfer. An inspection and registration fee will be charged for this service.

#### **EMISSION CONTROL SYSTEM WARRANTY**

Yamaha Motor Corporation, USA also warrants to the ultimate purchaser and each subsequent purchaser of each 2006 and later model Yamaha ATV covered by this warranty that the vehicle is designed, built, and equipped so as to conform at the time of sale with all U.S. emissions standards applicable at the time of manufacture and that it is free from defects in materials and workmanship which would cause it not to meet these standards

within the period listed immediately below. Failures other than those resulting from defects in material or workmanship which arise solely as a result of owner abuse and/or lack of proper maintenance are not covered by this warranty.

#### **All Models**

Thirty (30) months from the original purchase date

**YAMAHA MOTOR CORPORATION, U.S.A. MAKES NO OTHER WARRANTY OF ANY KIND, EXPRESSED OR IMPLIED. ALL IMPLIED WARRANTIES OF MERCHANTABILITY AND FITNESS FOR A PARTICULAR PURPOSE WHICH EXCEED THE OBLIGATIONS AND TIME LIMITS STATED IN THIS WARRANTY ARE HEREBY DISCLAIMED BY YAMAHA MOTOR CORPORATION, U.S.A. AND EXCLUDED FROM THIS WARRANTY.**

**SOME STATES DO NOT ALLOW LIMITATIONS ON HOW LONG AN IMPLIED WARRANTY LASTS, SO THE ABOVE LIMITATION MAY NOT APPLY TO YOU. ALSO EXCLUDED FROM THIS WARRANTY ARE ANY INCIDENTAL OR CONSEQUENTIAL DAMAGES INCLUDING LOSS OF USE. SOME STATES DO NOT ALLOW THE EXCLUSION OR LIMITATION OF INCIDENTAL OR CONSEQUENTIAL DAMAGES, SO THE ABOVE EXCLUSION MAY NOT APPLY TO YOU.**

**THIS WARRANTY GIVES YOU SPECIFIC LEGAL RIGHTS, AND YOU MAY ALSO HAVE OTHER RIGHTS WHICH VARY FROM STATE TO STATE.**

**YAMAHA MOTOR CORPORATION, U.S.A.**  
P.O. Box 6555  
Cypress, California 90630

## WARRANTY QUESTIONS AND ANSWERS

- Q. What costs are my responsibility during the warranty period?
- A. The customer's responsibility includes all costs of normal maintenance services, non-warranty repairs, accident and collision damages, and oil, oil filters, air filters, spark plugs, and brake shoes.
- Q. What are some examples of "abnormal" strain, neglect, or abuse?
- A. These terms are general and overlap each other in areas. Specific examples include: Running the machine out of oil, sustained high rpm, full-throttle, operating the machine with a broken or damaged part which causes another part to fail, damage or failure due to improper or careless transportation and or tie-down. If you have any specific questions on operation or maintenance, please contact your dealer for advice.
- Q. Does the warranty cover incidental costs such as towing or transportation due to a failure?
- A. No. The warranty is limited to repair of the machine itself.
- Q. May I perform any or all of the recommended maintenance shown in the Owner's Manual instead of having the dealer do them?
- A. Yes, if you are a qualified mechanic and follow the procedures specified in the Owner's and Service Manual. We do recommend, however, that items requiring special tools or equipment be done by a Yamaha ATV dealer.
- Q. Will the warranty be void or cancelled if I do not operate or maintain my new ATV exactly as specified in the Owner's Manual?
- A. No. The warranty on a new ATV cannot be "voided" or "cancelled." **However, if a particular failure is caused by operation or maintenance other than as described in the Owner's Manual, that failure may not be covered under warranty.**
- Q. What responsibility does my dealer have under this warranty?
- A. Each Yamaha ATV dealer is expected to:
1. Completely set up every new machine before sale.
  2. Explain the operation, maintenance, and warranty requirements to your satisfaction at the time of sale, and upon your request at any later date.
  3. Each Yamaha ATV dealer is held responsible for his setup, service and warranty repair work.
- Q. Is the warranty transferable to second owners?
- A. Yes. The remainder of the existing warranty can be transferred upon request. The unit has to be inspected and re-registered by an authorized Yamaha ATV dealer for the policy to remain effective.

## CUSTOMER SERVICE

If your machine requires warranty service, you must take it to any authorized Yamaha ATV dealer within the continental United States. Be sure to bring your warranty registration card or other valid proof of the original date of purchase. If a question or problem arises regarding warranty, first contact the owner of the dealership. Since all warranty matters are handled at the dealer level, this person is in the best position to help you. If you are still not satisfied and require additional assistance, please write:

YAMAHA MOTOR CORPORATION U.S.A.  
CUSTOMER RELATIONS DEPARTMENT  
P.O. Box 6555  
Cypress, California 90630

When contacting Yamaha Motor Corporation, U.S.A. don't forget to include any important information such as names, addresses, model, V.I.N. (frame number), dates, and receipts.

## CHANGE OF ADDRESS

The federal government requires each manufacturer of a motor vehicle to maintain a complete, up-to-date list of all first purchasers against the possibility of a safety-related defect and recall. This list is compiled from the purchase registrations sent to Yamaha Motor Corporation, U.S.A. by the selling dealer at the time of your purchase.

If you should move after you have purchased your new ATV, please advise us of your new address by sending a postcard listing your ATV model name, V.I.N. (frame number), dealer number (or dealer's name) as it is shown on your warranty card, your name and new mailing address. Mail to:

YAMAHA MOTOR CORPORATION, U.S.A.  
P.O. Box 6555  
Cypress, California 90630  
Attention: Warranty Department

This will ensure that Yamaha Motor Corporation, U.S.A. has an up-to-date registration record in accordance with federal law.

## YAMAHA EXTENDED SERVICE (Y.E.S.)

Keep your Yamaha protected even after your warranty expires with genuine Yamaha Extended Service (Y.E.S.).

- Y.E.S. is designed and administered by Yamaha Motor Corporation to provide maximum owner satisfaction. You get uninterrupted factory-backed coverage for extra peace of mind.
- Y. E. S. is flexible. You choose the plan that's right for you: 12 months, 24 months, or 36 months beyond your warranty period.
- Y.E.S. is designed and administered by the same Yamaha people who handle your warranty – and it shows in the comprehensive coverage benefits. There are no mileage limitations. Coverage isn't limited to "moving parts" or the "drive train" like many other plans. And Y.E.S. covers manufacturing defects just like the warranty. See the sample contract at your Yamaha dealer to see how comforting uninterrupted factory-backed protection can be.
- You don't have to pay anything for covered repairs. There's no deductible to pay, and repairs aren't "pro-rated." You don't have any "out-of-pocket" expenses for covered repairs.

- In addition, Travel and Recreation Interruption Protection (TRIP) is included at no extra cost. TRIP gives you up to \$150 reimbursement per occurrence for any reasonable expenses you incur because your Yamaha needs covered service: replacement vehicle rental, emergency towing, phone calls, even food and lodging when you are away from home. This superb coverage goes into effect when you purchase Y.E.S., so it applies to any warranty repairs as well as covered repairs during your entire Y.E.S. plan period.
- Y.E.S. coverage is honored at any authorized Yamaha dealer nationwide.
- Y.E.S. coverage is transferable to a new owner if you sell or trade in your ATV. That can make your Yamaha much more valuable!

This excellent Y.E.S. plan coverage is only available to Yamaha owners like you, and only while your Yamaha is still within the Yamaha Limited Warranty period. So visit your authorized Yamaha dealer to get all the facts. He can show you how easy it is to protect your investment with Yamaha Extended Service.



We urge you to act now. You'll get the excellent benefits of TRIP coverage right away, and you'll rest easy knowing you'll have strong factory-backed protection even after your Yamaha Limited Warranty expires. You can also save money: Y.E.S. costs less within the first 90 days after you buy your Yamaha. See your dealer today!

A special note:

If visiting your dealer isn't convenient, contact Yamaha with your Primary ID number (your frame number). We'll be happy to help you get the Y.E.S. coverage you need.

Yamaha Service Marketing  
P.O. Box 6555  
Cypress, CA 90630

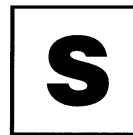

**YAMAHA EXTENDED SERVICE**



**Indicates a potential hazard that could result in serious injury or death.**

***PROTECT YOUR INVESTMENT***

***Use Genuine YAMAHA Parts and Accessories***

***See your Authorized YAMAHA Dealer for a Genuine YAMAHA Service Manual.***

# INDEX

## A

Accessories and loading .....	6-6
Accessories, auxiliary jack .....	4-23
Air filter element, cleaning .....	8-37
Axle boots .....	8-51

## B

Battery .....	8-55
Brake fluid, changing .....	8-48
Brake fluid level, checking .....	8-47
Brake hose protectors, checking the rear .....	8-46
Brake lever, front .....	4-15
Brake levers, checking and lubricating .....	8-53
Brake pads, checking the front and rear .....	8-45
Brake pedal and rear brake lever .....	4-15
Brake pedal, checking and lubricating .....	8-53
Brake pedal free play, adjusting .....	8-49
Brakes, front and rear .....	5-5

## C

Cables, checking and lubricating .....	8-52
Carrier, front .....	4-22
Carrier, rear .....	4-22
Chassis fasteners .....	5-9
Cleaning .....	9-1
Coolant .....	5-4, 8-31
Coolant temperature warning light .....	4-2

## D

Differential gear lock indicator light .....	4-4
Differential gear oil .....	5-4, 8-29

Drive select lever .....	4-16
Drive select lever and driving in reverse .....	6-3
Drive select lever safety system cable, adjusting .....	8-45

## E

Engine break-in .....	6-4
Engine oil .....	5-4
Engine oil and oil filter cartridge .....	8-22
Engine stop switch .....	4-7
Engine trouble warning light .....	4-3
EPS warning light (for EPS model) .....	4-3

## F

Final gear oil .....	5-4, 8-27
Four-wheel-drive/differential gear lock indicator .....	4-4
Front and rear brake lever free play, checking .....	8-48
Fuel .....	4-17, 5-4
Fuel tank cap .....	4-16
Fuses, replacing .....	8-58

## H

Handlebar switches .....	4-7
Headlight beam, adjusting .....	8-62
Headlight bulb, replacing .....	8-60
High-range indicator light .....	4-4

## I

Identification numbers .....	11-1
Indicator lights and warning lights .....	4-2
Instruments, lights and switches .....	5-9

## K

Key identification number .....	11-1
---------------------------------	------

## L

Label locations .....	2-1
Light switch .....	4-8
Low-range indicator light .....	4-4

## M

Main switch .....	4-1
Maintenance and lubrication chart .....	8-4
Maintenance chart, emission control system .....	8-3
Maintenance record .....	11-4
Model label .....	11-2
Multifunction display .....	4-5

## N

Neutral indicator light .....	4-2
Noise regulation .....	11-3

## O

On-Command differential gear lock switch .....	4-10
On-Command four-wheel-drive switch .....	4-9
Override switch .....	4-8
Owner's manual and tool kit .....	8-1

## P

Panels, removing and installing .....	8-8
Park indicator light .....	4-4
Parking .....	6-5
Parking on a slope .....	6-5
Part locations .....	3-1
Pre-operation check list .....	5-1

## R

Radiator grills, removing .....	8-20
Rear knuckle pivots, lubricating .....	8-54
Reverse indicator light .....	4-2
Riding your ATV .....	7-1

## S

Safety information .....	1-1
Seat .....	4-19
Shock absorber assemblies, adjusting the front and rear .....	4-22
Spark arrester, cleaning .....	8-41
Spark plug, checking .....	8-20
Specifications .....	10-1
Speed limiter .....	4-14
Stabilizer bushes, checking .....	8-54
Starting the engine .....	6-1
Start switch .....	4-8
Steering shaft, lubricating .....	8-55
Storage .....	9-2
Storage compartments .....	4-19

## T

Tail/brake light bulb, replacing .....	8-63
Throttle cable free play, adjusting .....	8-44
Throttle lever .....	4-13, 5-6
Tire pressure, measuring .....	5-7
Tires .....	5-6
Tire wear limit .....	5-8
Troubleshooting .....	8-65
Troubleshooting charts .....	8-67

## V

Valve clearance .....	8-45
V-belt case drain plug .....	8-43
Vehicle identification number .....	11-1

## W

Warranty, extended .....	11-7
Warranty, limited .....	11-5
Wheel hub bearings, checking .....	8-54

Wheel, installing .....	8-64
Wheel, removing .....	8-64





**⚠ WARNING**

**Improper ATV use can result in SEVERE INJURY or DEATH.**



**ALWAYS USE  
AN APPROVED  
HELMET AND  
PROTECTIVE GEAR**



**NEVER USE  
ON PUBLIC  
ROADS**



**NEVER CARRY  
PASSENGERS**



**NEVER USE  
WITH DRUGS  
OR ALCOHOL**

**NEVER operate:**

- without proper training or instruction.
- at speeds too fast for your skills or the conditions.
- on public roads-a collision can occur with another vehicle.
- with a passenger-passengers affect balance and steering and increase risk of losing control.

**ALWAYS:**

- use proper riding techniques to avoid vehicle overturns on hills and rough terrain and in turns.
- avoid paved surfaces-pavement may seriously affect handling and control.

**LOCATE AND READ OWNER'S MANUAL. FOLLOW ALL INSTRUCTIONS AND WARNINGS.**  
(For replacement manual, call 1-800-532-1558)



**YAMAHA**

YAMAHA MOTOR CO., LTD.



Dear Yamaha ATV Owner: Please Review this IMPORTANT SAFETY CARD before operating your ATV (If card is not attached, call 1-800-344-6418).

Dear New Yamaha ATV Owner:

CONGRATULATIONS ON THE PURCHASE OF YOUR NEW YAMAHA ATV. You have purchased a quality Yamaha product that, with proper use and care, will provide hours of riding pleasure. **BEFORE YOU OPERATE YOUR NEW ATV, Yamaha recommends these important points:**

- READ YOUR OWNER'S MANUAL
- A CHILD UNDER 6 YEARS OLD SHOULD NOT OPERATE AN ATV WITH ENGINE SIZE 50CC OR GREATER
- A CHILD UNDER 12 YEARS OLD SHOULD NOT OPERATE AN ATV WITH ENGINE SIZE 70CC OR GREATER
- A CHILD UNDER 16 YEARS OLD SHOULD NOT OPERATE AN ATV WITH ENGINE SIZE GREATER THAN 90CC
- TAKE THE FREE HANDS-ON TRAINING COURSE OFFERED BY YAMAHA - ASK YOUR DEALER FOR DETAILS OR CALL 1-800-887-2887

If you have any questions about these points, **or if you purchased your ATV from an authorized Yamaha dealership and were not informed of the age recommendation for your ATV by the dealership**, please fill out the information below and mail this card to yamaha **today**.

Name:

\_\_\_\_\_

ATV Model:

\_\_\_\_\_

Purchase Date:

\_\_\_\_\_

MO. DAY YR.

Address:

\_\_\_\_\_

Primary I.D. (Engine Number):

\_\_\_\_\_

Telephone:

( ) \_\_\_\_\_

Dealer Name & Address:

\_\_\_\_\_

This is not a warranty card

READ CAREFULLY



NO POSTAGE  
NECESSARY  
IF MAILED  
IN THE  
UNITED STATES

**BUSINESS REPLY MAIL**  
FIRST CLASS      PERMIT NO. 4      CYPRESS, CA

POSTAGE WILL BE PAID BY ADDRESSEE

**YAMAHA MOTOR CORPORATION U.S.A.  
P.O. BOX 6555  
CYPRESS, CALIFORNIA 90630-9989**

ATTN: SALES ADMINISTRATION

